

# SMARTS II Area Monitors

## Narda wideband area monitor

The SMARTS II area monitors provide continuous detection of RF radiation within a specific area. The SMARTS II uses wideband sensor technology. The result is an area monitor that covers most of the usable RF spectrum in a single monitor with shaped frequency response that matches the safety standard used to determine compliance. The dual sensor design detects all types of electromagnetic fields from 400 MHz to 100 GHz. The microwave portion of the sensor employs thermocouple detectors so that radar signals are accurately converted to true RMS values while the diode design used for the lower frequencies provides RMS detection even in very complex, multi-signal environments. SMARTS II monitors respond equally to all polarizations and cover almost a hemisphere.

- › Wideband SMARTS II area monitors
- › 400 MHz to 100 GHz in a single monitor
- › Shaped frequency response matched to your safety standard
- › Continuous, automatic monitoring – no operator required
- › Audible, visual, and remote alarms
- › Recorder output
- › Battery or low voltage DC operation
- › Adjustable alarm threshold



## Description

The SMARTS II detects all types of electromagnetic fields from 400 MHz to 100 GHz. The monitor uses a dual sensor design. The microwave portion of each sensor employs thermocouple detectors so that radar signals are accurately converted to true RMS values while the diode design used for the lower frequencies provides RMS detection even in very complex, multi-signal environments. The output of the high frequency sensors is combined and fed to a low-noise amplifier circuit. Similarly, the output of the low frequency sensors is combined and fed to another low-noise amplifier.

The output of these two amplifier circuits is scaled in terms of percent of the respective safety standard. The sum of these two amplifier levels is used to determine whether the monitor is above or below the alarm threshold that has been selected by the user. SMARTS II monitors respond equally to all polarizations and cover almost a hemisphere.

The SMARTS II operates from a 9-volt lithium Ultralife battery (U9VL) or a +12 V to +24 V DC supply. Every monitor has an audible and visual alarm indication. An alarm condition causes both a voltage transition to occur and, in the case of DC supply operation, a SPDT relay to operate. Either the voltage transition (+4 V/-4 V) signal or the relay contacts can be used to provide remote alarms, a record of alarm conditions, and/or automatic shutoff of equipment.

There is a SMARTS II model shaped to match most of the major safety standards:

- › FCC 1997 Occupational/Controlled
- › ICNIRP 1998 Occupational
- › IEEE C95.1-2019 Restricted Environments

## Applications

The SMARTS II performs measurements for human safety purposes, particularly in workplace environments where high electric or magnetic field strengths are likely.

The SMARTS II is an area monitor that can be installed on ceilings and walls, with automatic frequency response evaluation according to a selected safety standard. SMARTS II emits warning sounds if user settable thresholds are exceeded.

SMARTS II is ideal for security installations in aircraft hangars or military facilities, thanks to its frequency range from 400 MHz to 100 GHz and measurement range of up to 3000% of the limit value of the chosen safety standard.

## Operation

SMARTS II monitors operate like common household smoke detectors. When operating normally, the alarm LED flashes approximately every 40 seconds. If operating under battery power and the battery needs replacement, a “chirp” accompanies the LED flash. The SMARTS II goes into alarm mode if the battery drops below a critical level.

A continuous audible alarm and a LED flash every second occurs when the SMARTS II detects RF radiation at its preset level or higher. Both an electronic signal and, in the case of DC supply operation, a relay closure are provided during alarm conditions. Either of these indications can be used to activate various user-supplied remote circuitry and systems.

Operation can be verified at any time by depressing the TEST button that activates a full-system test. For battery operation that means an audible and visual alarm and an electronic signal and, at DC supply operation an additional relay activation.

The ENABLE input can be used in situations where the standard operating procedure produces RF field levels in excess of the threshold and exposure to people is possible (e.g., in an anechoic chamber or on the deck of a ship). The ENABLE input can be tied to a motion sensor or an interlock switch. Under these conditions, the SMARTS II activates its alarms only when two conditions are satisfied: (1) high levels of RF are present *and* (2) motion is detected or a door is open.

The alarm threshold is field adjustable from 10% of standard to 50% of standard. The user can easily switch from battery operation to an external, low voltage DC supply.



Fig. 1. SMARTS II on ceiling

## Definitions and conditions

### Conditions

Unless otherwise noted, specifications apply after 30 minutes warm-up time within the specified environmental conditions.

### Specifications with limits

These describe product performance for the given parameter covered by warranty. Specifications with limits (shown as  $<$ ,  $\leq$ ,  $>$ ,  $\geq$ ,  $\pm$ , max., min.) apply under the given conditions for the product and are tested during production, considering measurement uncertainty.

### Specifications without limits

These describe product performance for the given parameter covered by warranty. Specifications without limits represent values with negligible deviations, which are ensured by design (e.g. dimensions or resolution of a setting parameter).

### Typical values (typ.)

These characterize product performance for the given parameter that is not covered by warranty. When stated as a range or as a limit (shown as  $<$ ,  $\leq$ ,  $>$ ,  $\geq$ ,  $\pm$ , max., min.), they represent the performance met by approximately 80% of the instruments. Otherwise, they represent the mean value. The measurement uncertainty is not taken into account.

### Nominal values (nom.)

These characterize expected product performance for the given parameter that is not covered by warranty. Nominal values are verified during product development but are not tested during production.

### Uncertainties

These characterize the dispersion of the values attributed to the measurands with an estimated confidence level of approximately 95%. Uncertainty is stated as the standard uncertainty multiplied by the coverage factor  $k=2$  based on the normal distribution. The evaluation has been carried out in accordance with the rules of the "Guide to the Expression of Uncertainty in Measurement" (GUM).

## Outline drawing

### SMARTS II

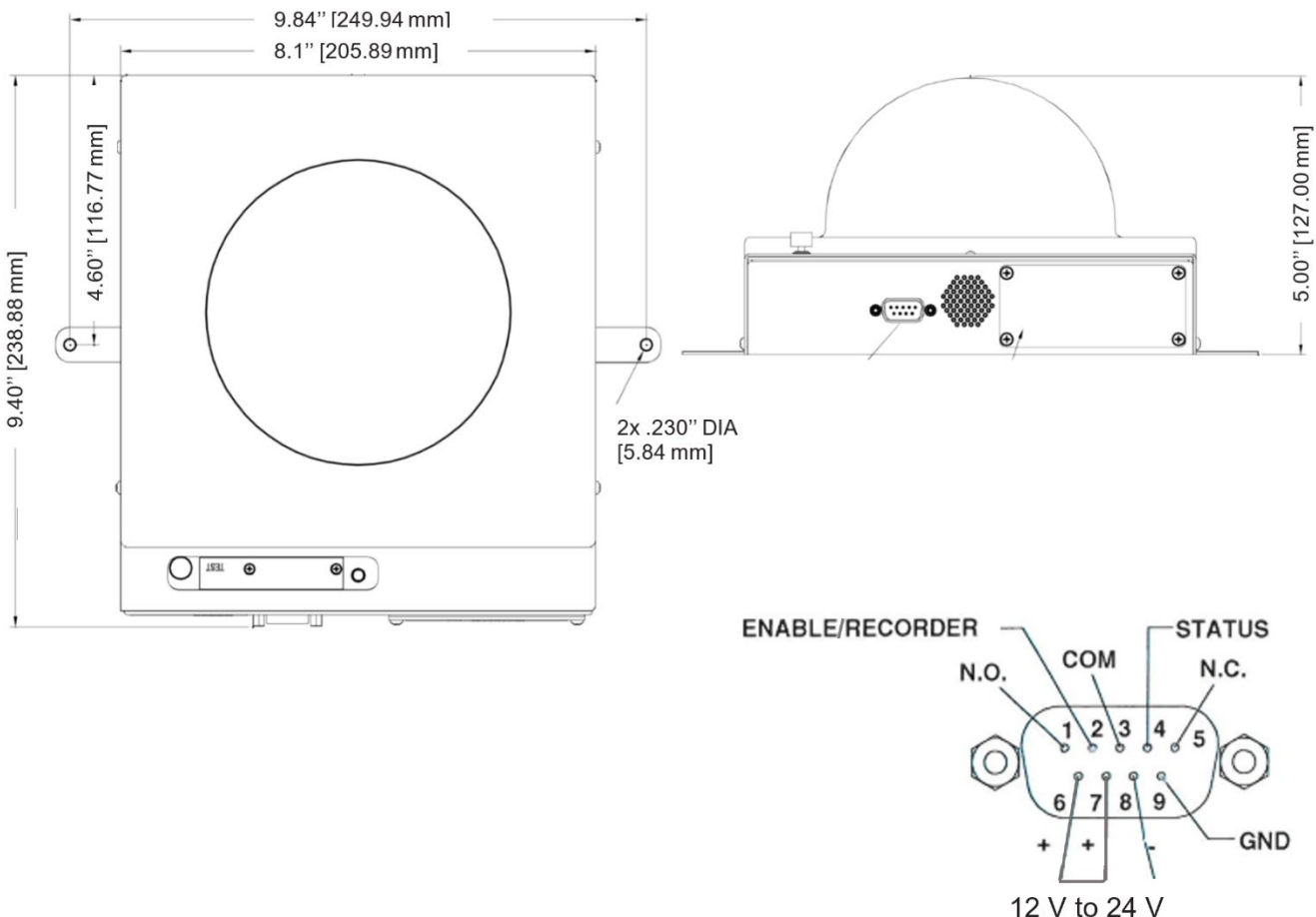

# Specifications

## Monitor Specifications

Parameter	Specification	
Frequency Range (nom.)	400 MHz to 100 GHz	
Field Measured	Electric Field	
Sensor Design	Diode and Thermocouple array	
Frequency Sensitivity	+6.0 / -3.0 dB (400 MHz to 2.3 GHz) +4.5 / -2.5 dB (2.3 to 30 GHz) +2.5 / -6.0 dB (30 to 50 GHz) +2.5 / -6.0 dB (50 to 100 GHz, nom.)	
3 dB intercept angle <sup>a</sup>	> 120° (400 MHz < f < 5 GHz) > 160° (f ≥ 5 GHz)	
Alarm Threshold	10%, 25%, 35%, or 50% of Standard <sup>b</sup>	
Alarm Indications	Audio, LED	
Maximum CW Power Density	3000% of Standard	
Maximum Peak Power Density	32 dB above Standard	
STATUS signal (nom.)	Levels	-4 V standby, +4 V alarm
	Load Impedance, min.	100 kΩ
Status Relay (for external power operation only)	Type	SPDT Relay
	Power rating	3 W @ 250 mA, 28 V
Recorder	Output Level (nom.)	-1 V (full scale) (start of alarm output @ -900 mV)
	Load Impedance, min.	100 kΩ
Accessories Supplied	Connector -- D-SUB, Backshell -- D-SUB, Battery, Operating Manual, Test Report	

## General Specifications

Parameter	Specification	
Recommended Functional Test Interval	2 years	
Battery Type	Ultralife U9VL volt lithium	
External Power Requirements <sup>c, d</sup>	12 V to 24 V, 50 mA	
Temperature	Operating	-10°C to +55°C
	Non-operating	-20°C to +55°C
Dimensions (H x W x D)	127 mm x 206 mm x 239 mm (5.0" x 8.1" x 9.4")	
Weight (approximate)	0.74 kg / 1.6 lb	
Color	White	
Country of Origin	Germany	

<sup>a</sup> Measured in free field.

<sup>b</sup> Determined by DIP switch setting inside battery compartment. There is an additional 1 dB uncertainty in the alarm threshold when the SMARTS II is set to 10% of Standard.

<sup>c</sup> A switch inside the battery compartment determines whether the battery or an external supply powers the monitor.

<sup>d</sup> The external power supply must be floating (not grounded).

## Ordering information

SMARTS II area monitor sets	Part number
SMARTS II Set, FCC 1997 Occupational/Controlled	<b>2688/101</b>
SMARTS II Set, ICNIRP 1998 Occupational	<b>2688/104</b>
SMARTS II Set, IEEE C95.1-2019 Restricted environm.	<b>2688/105</b>
<p><b>Each set includes:</b></p> <ul style="list-style-type: none"> <li>› Battery, 9.0V Lithium (2688/90.01)</li> <li>› Connector -- D-SUB (2688/90.02)</li> <li>› Backshell -- D-SUB (2688/90.03)</li> <li>› Operating Manual in English (2688/98.21)</li> <li>› Test Report (FCT2688 Functional Test)</li> </ul>	

**Narda Safety Test Solutions GmbH**  
Sandwiesenstrasse 7  
72793 Pfullingen, Germany  
Phone +49 7121 97 32 0  
info@narda-sts.com

[www.narda-sts.com](http://www.narda-sts.com)

**Narda Safety Test Solutions**  
North America Representative Office  
435 Moreland Road  
Hauppauge, NY 11788, USA  
Phone +1 631 231 1700  
info@narda-sts.com

**Narda Safety Test Solutions S.r.l.**  
Via Benessea 29/B  
17035 Cisano sul Neva, Italy  
Phone +39 0182 58641  
nardait.support@narda-sts.it



**emitec**  
industrial

Emitec Messtechnik AG  
Birkenstrasse 47  
63443 Rotkreuz

+41 41 748 60 10  
info@emitec.ch  
[www.emitec-industrial.ch](http://www.emitec-industrial.ch)



Emitec Group   
#1 in Test & Measurement, worldwide.

® Names and Logo are registered trademarks of Narda Safety Test Solutions GmbH - Trade names are trademarks of the owners.