

## SP-1U/2U Series High Performance Programmable DC Power Supply & System

»» Application Guide



- High Efficiency
- High Precision
- High Stability

# SP-1U/2U Series High Performance Programmable DC Power Supply & System

## SP-1U/2U Series High Performance Programmable DC Power Supply



600W~1600W



1000W~4000W

Output			Model	Size	Ripple		Response		Certificates				
Rated Voltage	Rated Current	Rated Power			Voltage	Current	Voltage increase	Voltage Drop					
20V	60A	600W	SP20VDC600W	1U ①	40mVp-p/6mVrms	20mA (TYP Value)	≤10ms(No load), ≤10ms(Full load)	≤150ms(No load), ≤20ms(Full load)	CE/RoHs				
		1000W	SP20VDC1000W					≤150ms(No load), ≤15ms(Full load)	CE/RoHs				
		1200W	SP20VDC1200W					≤150ms(No load), ≤12ms(Full load)	CE/RoHs				
32V	50A	600W	SP32VDC600W	1U ①	40mVp-p/6mVrms	20mA (TYP Value)	≤12ms(No load), ≤12ms(Full load)	≤150ms(No load), ≤20ms(Full load)	CE/RoHs				
		1000W	SP32VDC1000W					≤150ms(No load), ≤15ms(Full load)	CE/RoHs/CSA/FCC				
		1200W	SP32VDC1200W					≤150ms(No load), ≤12ms(Full load)	CE/RoHs/CSA/FCC				
	200A	1600W	SP32VDC1600W	1U ①	60mVp-p/10mVrms	200mA (TYP Value)	≤10ms(No load), ≤10ms(Full load)	≤150ms(No load), ≤10ms(Full load)	CE/RoHs/CSA/FCC				
		1000W	SPS32VDC1000W	2U ⑤				≤20ms(No load), ≤40ms(Full load)	≤500ms(No load), ≤45ms(Full load)	CE			
		2000W	SP32VDC2000W					≤20ms(No load), ≤30ms(Full load)	≤500ms(No load), ≤30ms(Full load)	CE			
40V	40A	600W	SP40VDC600W	1U ①	40mVp-p/6mVrms	20mA (TYP Value)	≤10ms(No load), ≤10ms(Full load)	≤150ms(No load), ≤20ms(Full load)	CE/RoHs				
		1000W	SP40VDC1000W					≤150ms(No load), ≤15ms(Full load)	CE/RoHs/CSA/FCC				
		1200W	SP40VDC1200W					≤150ms(No load), ≤12ms(Full load)	CE/RoHs/CSA/FCC				
	120A	1600W	SP40VDC1600W	1U ①	40mVp-p/6mVrms	20mA (TYP Value)	≤10ms(No load), ≤10ms(Full load)	≤150ms(No load), ≤10ms(Full load)	CE/RoHs/CSA/FCC				
		1000W	SPS40VDC1000W	2U ⑤				≤20ms(No load), ≤40ms(Full load)	≤500ms(No load), ≤45ms(Full load)	CE/RoHs			
		2000W	SP40VDC2000W					≤20ms(No load), ≤30ms(Full load)	≤500ms(No load), ≤30ms(Full load)	CE/RoHs			
75V	25A	600W	SP75VDC600W	1U ②	40mVp-p/6mVrms	10mA (TYP Value)	≤10ms(No load), ≤10ms(Full load)	≤160ms(No load), ≤20ms(Full load)	CE/RoHs/CSA				
		1000W	SP75VDC1000W					≤160ms(No load), ≤15ms(Full load)	CE/RoHs/CSA/FCC				
		1200W	SP75VDC1200W					≤160ms(No load), ≤12ms(Full load)	CE/RoHs/CSA/FCC				
	60A	1500W	SP75VDC1500W	2U ④	40mVp-p/8mVrms	10mA (TYP Value)	≤15ms(No load), ≤15ms(Full load)	≤160ms(No load), ≤10ms(Full load)	CE/RoHs/CSA/FCC				
		4000W	SP75VDC4000W					≤450ms(No load), ≤20ms(Full load)	CE/RoHs/CSA/FCC				
		1000W	SP80VDC1000W					2U ④	≤15ms(No load), ≤15ms(Full load)	≤450ms(No load), ≤30ms(Full load)	CE		
2000W	SP80VDC2000W	CE/RoHs											
120V	40A	3000W	SP80VDC3000W	2U ④	80mVp-p/15mVrms	10mA (TYP Value)	≤20ms(No load), ≤20ms(Full load)	≤350ms(No load), ≤21ms(Full load)	CE/RoHs				
		1000W	SPS120VDC1000W					CE/RoHs					
		2000W	SP120VDC2000W					CE/RoHs/CSA/FCC					
		3000W	SP120VDC3000W					CE/RoHs/CSA/FCC					
150V	10A	4000W	SP120VDC4000W	2U ④	80mVp-p/15mVrms	10mA (TYP Value)	≤25ms(No load), ≤25ms(Full load)	≤350ms(No load), ≤21ms(Full load)	CE/RoHs				
		600W	SP150VDC600W					1U ③	120mVp-p/40mVrms	10mA (TYP Value)	≤25ms(No load), ≤25ms(Full load)	≤400ms(No load), ≤32ms(Full load)	CE/RoHs
		1000W	SP150VDC1000W						CE/RoHs				
	30A	1200W	SP150VDC1200W	2U ④	80mVp-p/15mVrms	10mA (TYP Value)	≤25ms(No load), ≤25ms(Full load)	≤400ms(No load), ≤32ms(Full load)	CE/RoHs				
		1500W	SP150VDC1500W					CE/RoHs					
		1000W	SPS150VDC1000W					CE/RoHs					
200V	8A	2000W	SP150VDC2000W	2U ④	150mVp-p/30mVrms	20mA (TYP Value)	≤30ms(No load), ≤30ms(Full load)	≤500ms(No load), ≤25ms(Full load)	CE/RoHs/CSA/FCC				
		3000W	SP150VDC3000W					CE/RoHs/CSA/FCC					
		4000W	SP150VDC4000W					CE/RoHs/CSA/FCC					
	24A	600W	SP200VDC600W	1U ③	120mVp-p/40mVrms	10mA (TYP Value)	≤30ms(No load), ≤30ms(Full load)	≤600ms(No load), ≤50ms(Full load)	CE/RoHs				
		1000W	SP200VDC1000W					≤600ms(No load), ≤40ms(Full load)	CE/RoHs				
		1200W	SP200VDC1200W					≤600ms(No load), ≤36ms(Full load)	CE/RoHs				
600V	10A	1500W	SP200VDC1500W	2U ④	150mVp-p/30mVrms	20mA (TYP Value)	≤30ms(No load), ≤30ms(Full load)	≤600ms(No load), ≤30ms(Full load)	CE/RoHs				
		1000W	SPS200VDC1000W					CE/RoHs					
		2000W	SP200VDC2000W					CE/RoHs					
		3000W	SP200VDC3000W					CE/RoHs					
800V	7.5A	4000W	SP200VDC4000W	2U ⑤	800mVp-p/200mVrms	10mA (TYP Value)	≤60ms(No load), ≤60ms(Full load)	≤500ms(No load), ≤20ms(Full load)	CE/RoHs				
		1000W	SPS600VDC1000W					CE/RoHs					
		2000W	SP600VDC2000W					CE/RoHs					
		3000W	SP600VDC3000W					CE/RoHs					
800V	7.5A	4000W	SP600VDC4000W	2U ⑤	800mVp-p/200mVrms	10mA (TYP Value)	≤60ms(No load), ≤60ms(Full load)	≤800ms(No load), ≤110ms(Full load)	CE/RoHs				
		2000W	SP800VDC2000W					≤800ms(No load), ≤90ms(Full load)	CE/RoHs				
		3000W	SP800VDC3000W					≤800ms(No load), ≤75ms(Full load)	CE/RoHs				
		4000W	SP800VDC4000W					≤800ms(No load), ≤60ms(Full load)	CE/RoHs				

# SP-1U/2U Series High Performance Programmable DC Power Supply & System

## SPS Series DC Power Supply System



13U



27U



19U

Rated Voltage	Output		Model	Size	Certificates
	Rated Current	Rated Power			
32V	600A	12kW	SPS32VDC12000W-2-13	13U <sup>6</sup>	CE
	1200A	24kW	SPS32VDC24000W-2-19	19U <sup>7</sup>	
	2000A	40kW	SPS32VDC40000W-2-27	27U <sup>8</sup>	
40V	360A	12kW	SPS40VDC12000W-2-13	13U <sup>6</sup>	
	720A	24kW	SPS40VDC24000W-2-19	19U <sup>7</sup>	
	1200A	40kW	SPS40VDC40000W-2-27	27U <sup>8</sup>	
75V	180A	12kW	SPS75VDC12000W-2-13	13U <sup>6</sup>	
	360A	24kW	SPS75VDC24000W-2-19	19U <sup>7</sup>	
	600A	40kW	SPS75VDC40000W-2-27	27U <sup>8</sup>	
80V	180A	9kW	SPS80VDC9000W-2-13	13U <sup>6</sup>	
	360A	18kW	SPS80VDC18000W-2-19	19U <sup>7</sup>	
	600A	30kW	SPS80VDC30000W-2-27	27U <sup>8</sup>	
96V	200A	12kW	SPS96VDC12000W-2-13	13U <sup>6</sup>	
	120A	12kW	SPS120VDC12000W-2-13	13U <sup>6</sup>	
120V	240A	24kW	SPS120VDC24000W-2-19	19U <sup>7</sup>	
	400A	40kW	SPS120VDC40000W-2-27	27U <sup>8</sup>	
	90A	12kW	SPS150VDC12000W-2-13	13U <sup>6</sup>	
150V	180A	24kW	SPS150VDC24000W-2-19	19U <sup>7</sup>	
	300A	40kW	SPS150VDC40000W-2-27	27U <sup>8</sup>	
	200A	24kW	SPS192VDC24000W-2-19	19U <sup>7</sup>	
192V	200A	24kW	SPS192VDC24000W-2-19	19U <sup>7</sup>	
	72A	12kW	SPS200VDC12000W-2-13	13U <sup>6</sup>	
	144A	24kW	SPS200VDC24000W-2-19	19U <sup>7</sup>	
200V	144A	24kW	SPS200VDC24000W-2-19	19U <sup>7</sup>	
	240A	40kW	SPS200VDC40000W-2-27	27U <sup>8</sup>	

Rated Voltage	Output		Model	Size	Certificates
	Rated Current	Rated Power			
225V	60A	12kW	SPS225VDC12000W-2-13	13U <sup>6</sup>	CE
240V	60A	9kW	SPS240VDC9000W-2-13	13U <sup>6</sup>	
	120A	24kW	SPS240VDC24000W-2-19	19U <sup>7</sup>	
320V	200A	40kW	SPS320VDC40000W-2-27	27U <sup>8</sup>	
360V	40A	12kW	SPS360VDC12000W-2-13	13U <sup>6</sup>	
400V	120A	40kW	SPS400VDC40000W-2-27	27U <sup>8</sup>	
450V	30A	12kW	SPS450VDC12000W-2-13	13U <sup>6</sup>	
	60A	24kW	SPS450VDC24000W-2-19	19U <sup>7</sup>	
480V	60A	18kW	SPS480VDC18000W-2-19	19U <sup>7</sup>	
600V	30A	12kW	SPS600VDC12000W-2-13	13U <sup>6</sup>	
	60A	24kW	SPS600VDC24000W-2-19	19U <sup>7</sup>	
	100A	40kW	SPS600VDC40000W-2-27	27U <sup>7</sup>	
720V	40A	24kW	SPS720VDC24000W-2-19	19U <sup>7</sup>	
750V	60A	40kW	SPS750VDC40000W-2-27	27U <sup>8</sup>	
800V	22.5A	12kW	SPS800VDC12000W-2-13	13U <sup>6</sup>	
	45A	24kW	SPS800VDC24000W-2-19	19U <sup>7</sup>	
	60A	30kW	SPS800VDC30000W-2-27	27U <sup>8</sup>	
	75A	40kW	SPS800VDC40000W-2-27	27U <sup>8</sup>	
900V	30A	24kW	SPS900VDC24000W-2-19	19U <sup>7</sup>	
1200V	24A	24kW	SPS1200VDC24000W-2-19	19U <sup>7</sup>	
	40A	40kW	SPS1200VDC40000W-2-27	27U <sup>8</sup>	

This formula is the standard cabinet for SP-2U model; it is available to select cabinet with different specification according to exact situation.

## Dimensions & Weight



① 423.0x44.0x447.0 mm & 9.2kg



② 423.0x44.0x447.0 mm & 8.9kg



③ 423.0x44.0x447.0 mm & 9.3kg



④ 423.0x87.0x469.0 mm & 13.2kg



⑤ 423.0x87.0x514.0 mm & 14.7kg



⑥ 600.0x576.0x700.0mm & 53.5kg+15kg\*3(REF)



⑦ 600.0x843.0x700.0mm & 100kg+15kg\*6(REF)



⑧ 600.0x1196.0x700.0mm & 120kg+15kg\*10(REF)

# SP-1U/2U Series High Performance Programmable DC Power Supply & System

## Features

- Low ripple and noise
- High accuracy and high resolution
- CC and CV working mode switch freely
- Support LIST/SEQUENCE file editing
- OVP/OCV/OPP/OTP/SCP
- Remote compensation
- With external analog control input interface
- Standard USB/LAN/RS485/RS232 communication interface
- Master/Slave parallel and series operation mode for up to 10 units

## Optional Information

GPIB communication card & cables

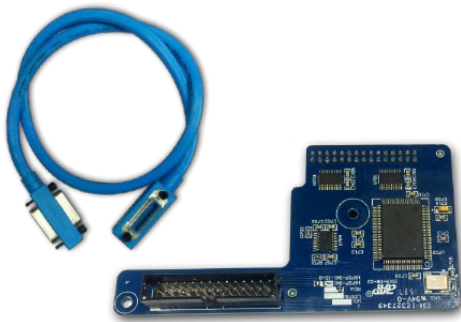

Three-core input cable (Input voltage range 176-265V, only supported on 1U height units)



## Front Panel Introduction

1U Power Supply Front Panel



2U Power Supply Front Panel



Key	Introduction
	Numeric Key
	Decimal Point
	Escape
	UP, used for choose menu or increase set value in menu operation
	DOWN, used for choose menu or decrease set value in menu operation
	Enter
	Set power supply's output voltage value
	Set power supply's output current-limiting value

Key	Introduction
	Press it to back to the main interface quickly
	Control ON/OFF of power supply
	Menu
	Work with functional keys to realize multifunction
LOCAL	Panel operation
RECALL	Recall stored setting value of power supply from internal storage
STORE	Store current settings of power supply to storage location
DVM/POWER	Display DVM value and power value

## SP Series Back Panel Introduction

### 1U Power Supply Back Panel

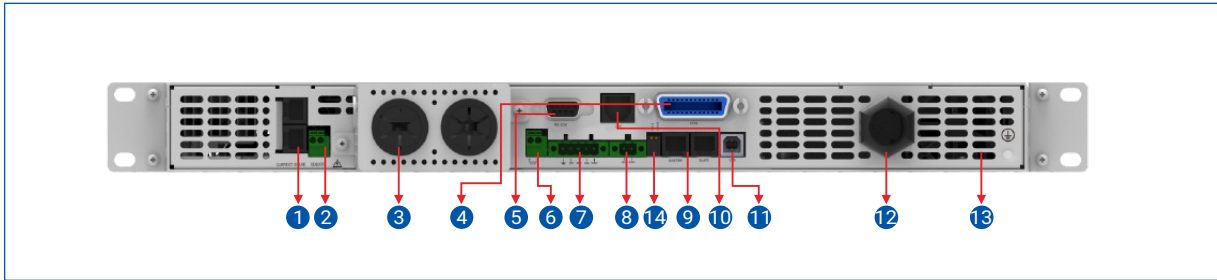

### 2U Power Supply Back Panel

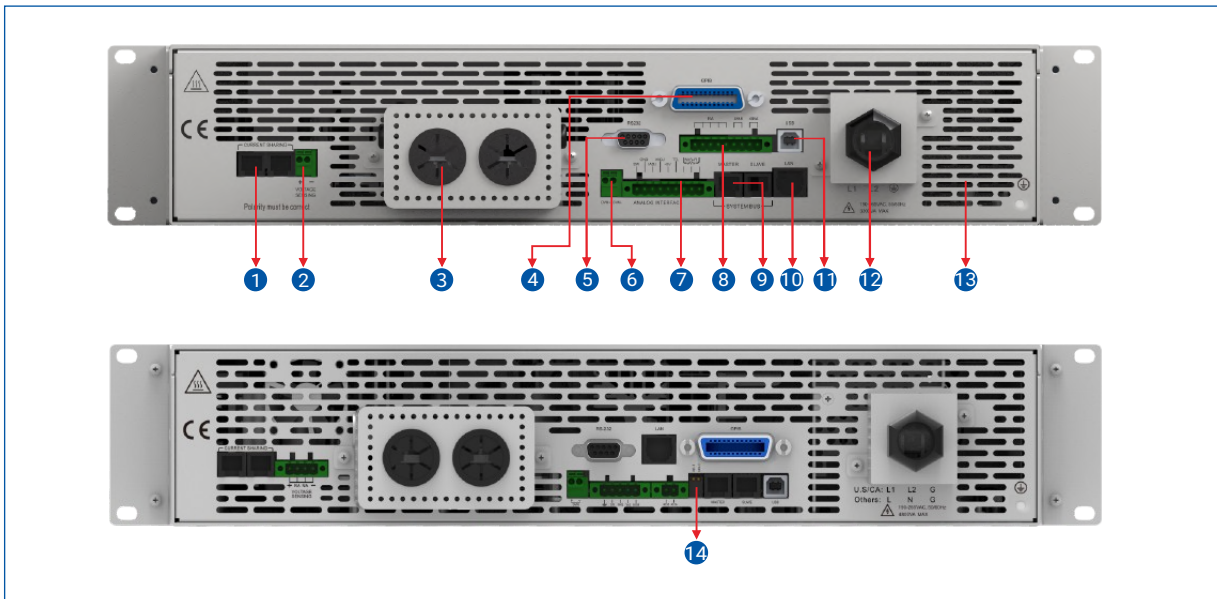

- ① AVG1/AVG2 Connector, used for connecting between units to enable current sharing.
- ② Voltage Remote Supporting Connector (VOLTAGE SENSING): Used to support wire voltage drops.
- ③ DC output terminal: Left (-), Right (+).
- ④ GPIB Communication connector.
- ⑤ RS-232 Communication connector.
- ⑥ DVM Connector.
- ⑦ ANALONG INTERFACE signal connection terminal.
- ⑧ RS-485 Communication connector.
- ⑨ SYSTEM BUS control, used for transmission of master and slaves.
- ⑩ LAN Communication Interface.
- ⑪ USB Communication Interface.
- ⑫ AC Power Connection terminal.
- ⑬ The fan duct outlet.
- ⑭ Termination resistor for RS485 and CAN Communication.

**Note:** There is a slight difference between these two kinds of rear panels of 2U units.

## Short Mode

This function is applicable to cable/fuse current carrying capacity test, when activated, the power supply will shutdown the short circuit protection function and maintain ultra-low voltage to output rated current.

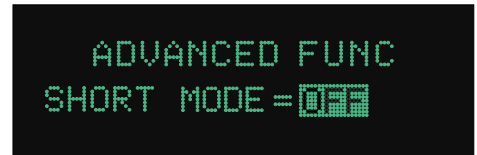
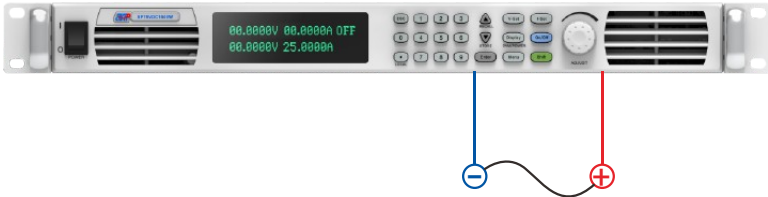

## Timer Control Function

This function is applicable to unattended occasions, activate the timer and the output, the screen will show the countdown of the timer. Once it reaches down to zero, the supply will turn off the output automatically. And the full protection of the power supply will make sure the safe usage of this function.

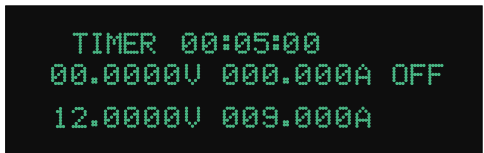
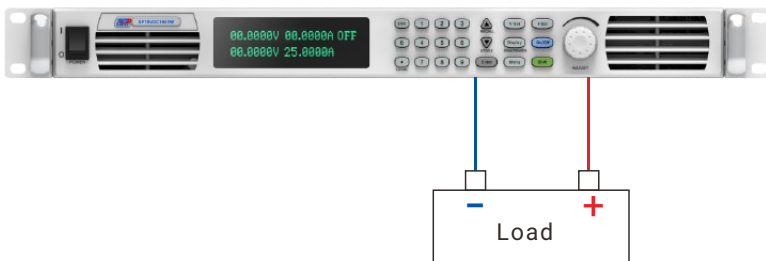

## Remote Compensation Function

This function is applicable to compensate the voltage drop on the load line in order to improve the accuracy of test. In practical applications, even if the voltage drop is negligible, it is best to connect the remote compensation cable to the output terminal. When using the remote compensation functionality, please disconnect the S+, S- from the power supply's output terminal, and connect them to both ends of the DUT. Maximum compensation voltage is up to 5V. The output power need be lower than 1.05% of the rated power after compensation.

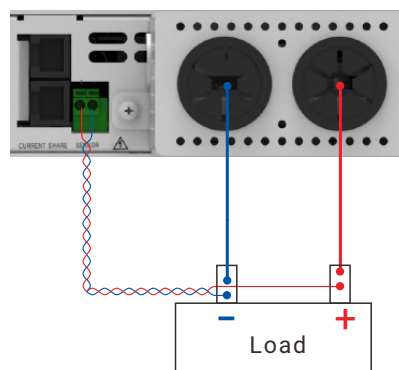

## External Control Function

This series power supply can offer external voltage/ potentiometers control output, can be controlled by external voltage(0~5V) or external potentiometers(5~10K) in order to remotely adjust the power supply voltage and current regulation settings and the output status of the power supply.

### External Voltage Control



### External Potentiometer Control



## LIST Waveform Editing Function

This series power supply supports 3 kinds of LIST file editing format in order to meet the output elements of different test requirements. The minimum resolution of time setting is 1ms.

### Impulse File Format

Sets the trend of the output voltage over time and its duration. Set the mode of the output waveform execution as required, LOOP, CONT, STEP.

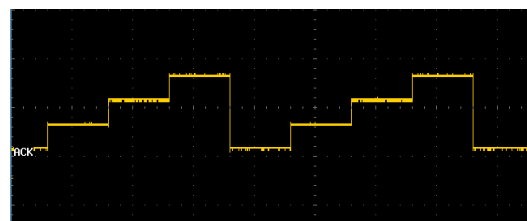
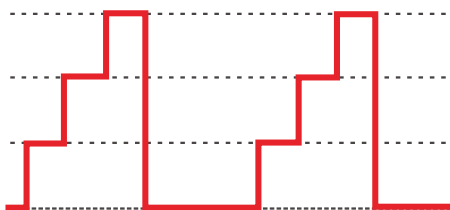

### Slope File Format

Support to set the slope of output voltage, achieve to slowly increase and drop of the output voltage. Set the mode of the output waveform execution as required, LOOP, CONT, STEP.

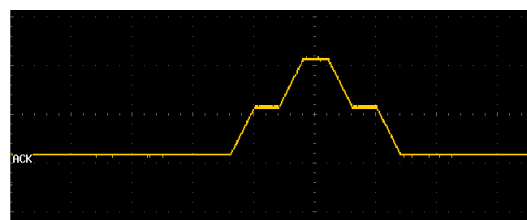
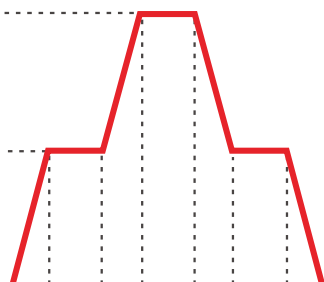

## SEQUENCE Waveform Editing function

This function is an upgrade version of the LIST file editing. Its every step is a complete LIST file. It can combine several LIST file and output, meanwhile, it can set the number of repetitions per LIST file and number of executions of the entire SEQUENCE file.

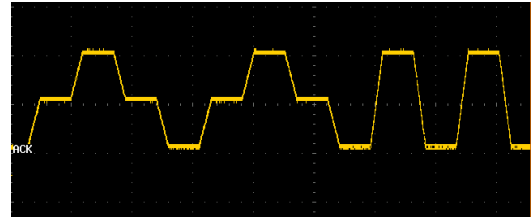

## Measure Average Function

Under this mode, if the DUT has a sharp change in voltage and current, the averaging times can be adjusted to be FAST, MEDIUM or SLOW to make the displayed value more stable.

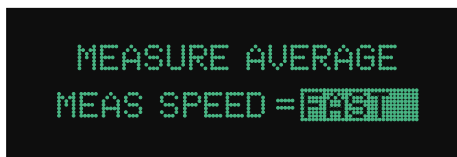

## Current Counting Function

This function offers testing of the cutoff time of a breaker or a fuse. Starts timing when the current reaches the circuit breaker or fuse's fusing current  $I_b$ , stops timing when disconnected, the timing resolution is up to 200ms.

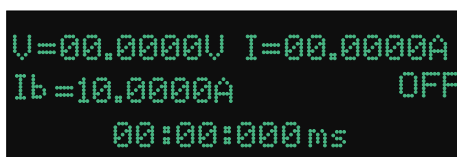

## Quick Recall Function

Support to recall the stored parameters directly by the numeric keys on the front panel. Firstly, user stores the frequently used data in the power supply's memory, press the numeric key directly after entering the quick recall mode, can quick recall the datas which are stored in **【1】** ~ **【9】**

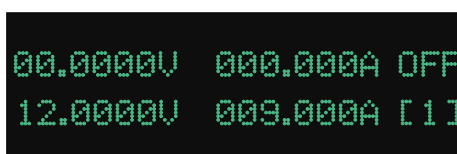

## Master/Slave Mode

This series power supply support Master/Slave parallel and series operation mode for up to 10 units, extended power up to 40kW. The current sharing function in parallel mode realizes the equalization of the power supplies in the system, thereby ensuring the extended power without affecting the performance index of the power supply. CAN parallel mode realizes the same dynamic response of the system as single unit, realizing high-speed and non-delayed synchronous response of master and slave.

### Parallel Connection

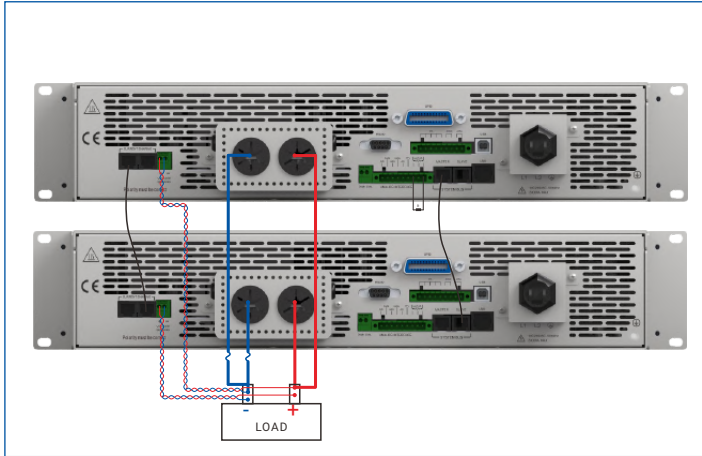

### Series Connection

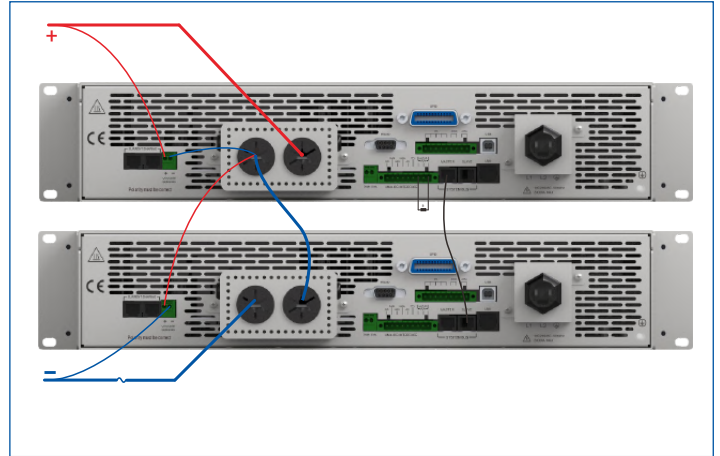

## Positive / Negative Voltage Output Mode

This mode which enables both positive and negative outputs simultaneously in master slave operation.

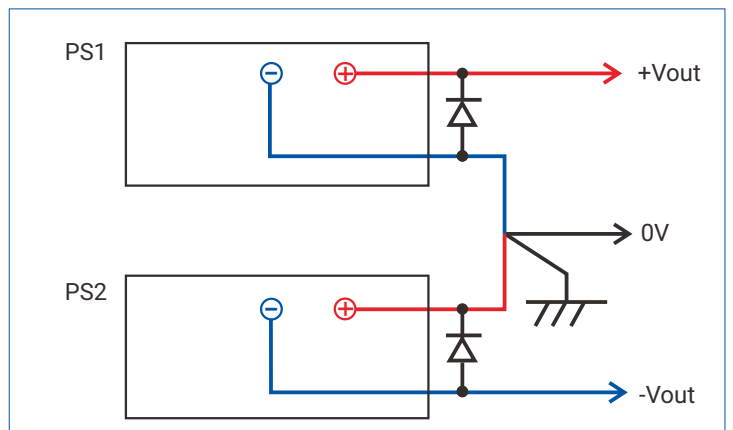
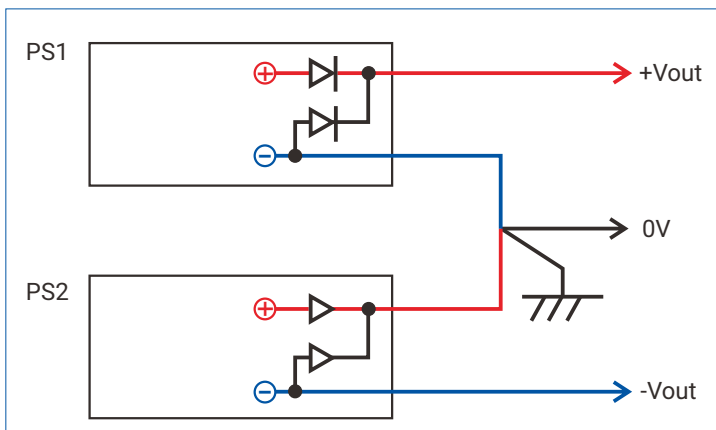
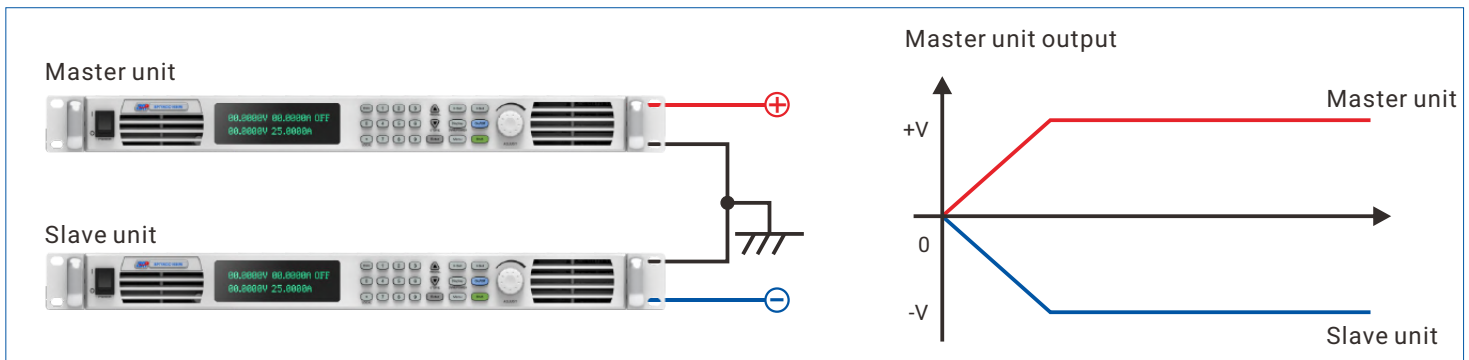

The power supply below 200A has been connected with anti reverse diode, so the external diode isn't needed in the actual connection, and the 200A power supply needs to connect the diode.

# SP-1U/2U Series High Performance Programmable DC Power Supply & System

## Built-in Standard Automobile Electric Test Waveform

It can be used to simulate the transient interference of power supply which may often be encountered in the process of automobile startup and operation. In accordance with industry standards, this series power supply has built-in voltage curves under the DIN40839 and ISO 16750-2 standards for 12V and 24V test grades. User can call the voltage curve directly for testing or edit as desired.

The built-in standard waveform cutline and file names are as below:

No.	Standard	Test item name	Waveform	List/Sequence File Name(Built-in)
1	ISO16750-2	Automobile Start Transient Voltage Drop		List 3-2 (12V Voltage Grade) List 3-7 (24V Voltage Grade)
2	ISO16750-2	Automobile Electronic Restoration Function Test		Sequence1 (includes List 3-3 and List 3-4, for 12V system) Sequence 2 (includes List 3-8 and List 3-9, for 24V system)
3	ISO16750-2	Automobile Electronic Engine Start Test		List 3-5
4	DIN40839	Automobile Electronic Engine Start Test		List 3-1

## Anti reverse irrigation/Power Sink Function

This series power supply has protection against reverse irrigation, so as to cut off the current of DUT in a certain test condition to the direction of power supply, and prevent the damage to the power supply hardware circuit from DUT.



Meanwhile, this series power supply comes standard with short circuit copper sheet, When the test requires the power supply to absorb the spike generated by DUT to ensure the safety of the operation, the short-circuit copper piece can be connected, and the energy is absorbed by the output capacitor inside the power supply and other circuits.



**Note:** Please consult your sales representative to get detailed information about anti reverse irrigation protection for power supply models above 200A.

## Monitoring Software

All power supplies come standard with graphical monitoring software, which supports all communication interfaces and covers almost all functions of the power supply front panel operation. In the communication selection interface, users can select the communication interface and search for the connected power supply according to the actual connection.

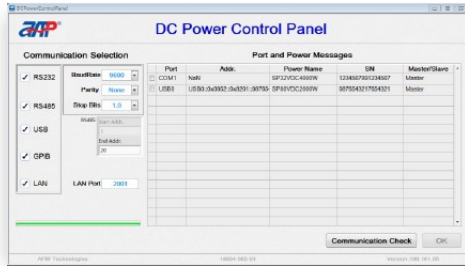

When the communication port has only one power supply connection, it enters the Single Mode interface. Includes the basic settings of voltage and current and measurement function, and List waveform editing/ saved test data function.

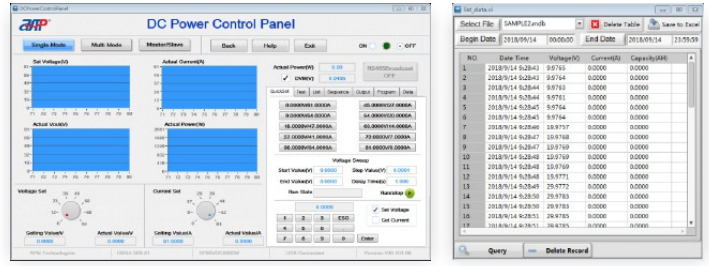

When the communication port has more than one power supply connection, it enters the Multi Mode interface. Supports switching control or display current power supply's settings.

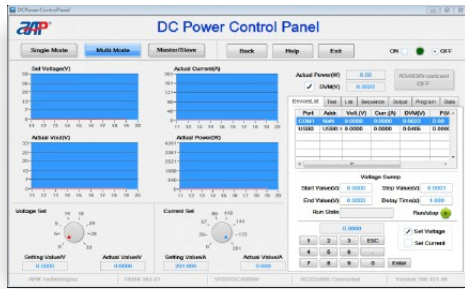

When the communication port connects the power supply that is the Master unit, it enters Master/Slave interface. The Master/Slave interface only maintains communication with the Master unit, and the parameters are synchronously written to the slaves.

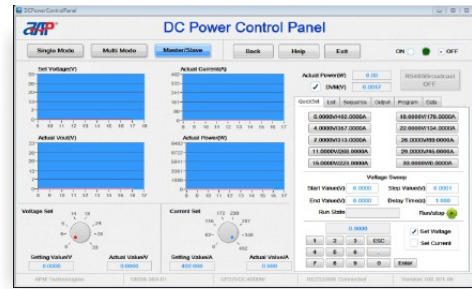

## WebServer Function

Use can control the power supply on a computer using a web browser. No need to install the monitoring software, just open web browser and input IP address to control the unit, which can meet basic setting and monitoring requirements.

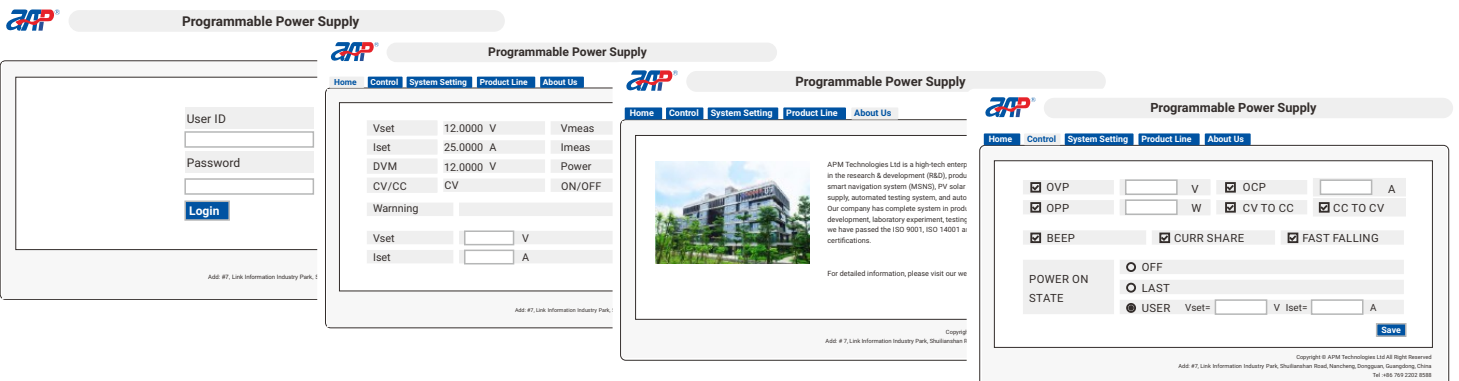



Emitec Messtechnik AG  
Birkenstrasse 47  
6343 Rotkreuz

+41 41 748 60 10  
info@emitec.ch  
www.emitec-industrial.ch



Emitec Group   
#1 in Test & Measurement, worldwide.