



Emitec Messtechnik AG
Birkenstrasse 47
6343 Rotkreuz

+41 41 748 60 10
info@emitec.ch
www.emitec-industrial.ch



Emitec Group 
#1 in Test & Measurement, worldwide.

DL950

ScopeCorder

USER'S MANUAL

Thank you for purchasing the DL950 ScopeCorder. This User's Manual explains how to use the instrument. To ensure correct use, please read this manual thoroughly before operation. After reading this manual, keep it in a safe place. The manuals for this instrument are listed on page iii. Please read all manuals.

Contact information of Yokogawa offices worldwide is provided on the following sheet.

Document No.	Description
PIM 113-01Z2	List of worldwide contacts

Notes

- The contents of this manual are subject to change without prior notice as a result of continuing improvements to the instrument's performance and functionality. The figures given in this manual may differ from those that actually appear on your screen.
- Every effort has been made in the preparation of this manual to ensure the accuracy of its contents. However, should you have any questions or find any errors, please contact your nearest YOKOGAWA dealer.
- Copying or reproducing all or any part of the contents of this manual without the permission of YOKOGAWA is strictly prohibited.
- The TCP/IP software of this product and the documents concerning it have been developed/created by YOKOGAWA based on the BSD Networking Software, Release 1 that has been licensed from the Regents of the University of California.

Trademarks

- Microsoft, Internet Explorer, Windows, Windows 8.1, and Windows 10 are registered trademarks or trademarks of Microsoft Corporation in the United States and/or other countries.
- Adobe and Acrobat are either registered trademarks or trademarks of Adobe Systems Incorporated.
- Piezotron is a registered Trademark of Kistler Instrumente AG.
- ICP is a registered trademark of PCB Piezotronics Incorporated.
- ISOTRON is a registered trademark of Meggitt Group, PLC.
- VJE is a registered trademark of Yahoo Japan Corporation.
- MATLAB is a registered trademark of The MathWorks, Inc. in the United States.
- GIGAZOOM ENGINE is a registered trademark of YOKOGAWA Electric Corporation.
- In this manual, the ® and TM symbols do not accompany their respective registered trademark or trademark names.
- Other company and product names are trademarks or registered trademarks of their respective holders.

Revisions

- 1st Edition: February 2021

Manuals

The following manuals, including this one, are provided as manuals for this instrument. Please read all manuals.

Manual Title	Manual No.	Description
DL950 ScopeCoder Features Guide	IM DL950-01EN	The supplied CD contains the PDF file of this manual. This manual explains all the instrument's features other than the communication interface features.
DL950 ScopeCoder User's Manual	IM DL950-02EN	This document. The supplied CD contains the PDF file of this manual. The manual explains how to operate this instrument.
DL950 ScopeCorder Getting Started Guide	IM DL950-03EN	Provided as a printed manual. This guide explains the handling precautions, common operations, troubleshooting measures, and specifications of this instrument.
DL950 ScopeCorder Communication Interface User's Manual	IM DL950-17EN	The supplied CD contains the PDF file of this manual. Explains the functions of the this instrument's communication interface, how to configure it, and how to control this instrument from a PC using the interface.
Precautions Concerning the Modules	IM 701250-04E	The manual explains the precautions concerning the modules. This manual is included if you ordered modules.
DL950 ScopeCorder	IM DL950-92Z1	Document for China.

The "EN", "E", and "Z1" in the manual numbers are the language codes.

Manuals in the CD

The included CD (manual CD) contains the following English and Japanese manuals.

File Name	Manual No.	Description
Features Guide & Users Manual.pdf	IM DL950-01EN	Features Guide and User's Manual
Communication Interface.pdf	IM DL950-17EN	Communication Interface User's Manual

Online Help

Contents similar to those in the Features Guide, IM DL950-01EN, are included in this instrument as a help file (some the content may be omitted). For instructions on how to use the help, see section 4.11 in the *Getting Started Guide*, IM DL950-03EN.

Conventions Used in This Manual

Notes and Cautions

The notes and cautions in this manual are categorized using the following symbols.



Improper handling or use can lead to injury to the user or damage to the instrument. This symbol appears on the instrument to indicate that the user must refer to the user's manual for special instructions. The same symbol appears in the corresponding place in the user's manual to identify those instructions. In the manual, the symbol is used in conjunction with the word "WARNING" or "CAUTION."

WARNING

Calls attention to actions or conditions that could cause serious or fatal injury to the user, and precautions that can be taken to prevent such occurrences.

CAUTION

Calls attention to actions or conditions that could cause light injury to the user or damage to the instrument or user's data, and precautions that can be taken to prevent such occurrences.

Note

Calls attention to information that is important for the proper operation of the instrument.

French



Une manipulation ou une utilisation incorrectes risquent de blesser l'utilisateur ou d'endommager l'instrument. Ce symbole apparaît sur l'instrument pour indiquer à l'utilisateur qu'il doit se reporter au manuel de l'utilisateur afin d'y lire les instructions spécifiques correspondantes. Ce même symbole apparaît à la section correspondante du manuel de l'utilisateur pour signaler lesdites instructions. Dans le manuel de l'utilisateur, ce symbole est accompagné des termes AVERTISSEMENT et ATTENTION.

AVERTISSEMENT

Attire l'attention sur des gestes ou des conditions susceptibles de provoquer des blessures graves (voire mortelles), et sur les précautions de sécurité pouvant prévenir de tels accidents.

ATTENTION

Attire l'attention sur des gestes ou des conditions susceptibles de provoquer des blessures légères ou d'endommager l'instrument ou les données de l'utilisateur, et sur les précautions de sécurité susceptibles de prévenir de tels accidents.

Prefixes k and K

This manual distinguishes prefixes k and K used before units as follows:

k: Denotes 1000. Example: 100 kS/s (sample rate)

K: Denotes 1024. Example: 720 KB (file size)

Contents

Manuals	iii
Conventions Used in This Manual	iv

Chapter 1 Setup

1.1	Setting the Operation Mode	1-2
1.2	Initializing the Settings	1-3
1.3	Performing Auto Setup	1-4
1.4	Configuring with the Application Menu	1-5

Chapter 2 Channel Setup

2.1	Configuring Voltage Measurements (on modules other than 16-CH temperature/voltage input modules)	2-2
2.2	Configuring Voltage Measurements (on 16-CH temperature/voltage input modules)	2-12
2.3	Configuring Temperature Measurements (on modules other than 16-CH temperature/voltage input modules)	2-18
2.4	Configuring Temperature Measurements (For 16-CH temperature/voltage input modules)	2-20
2.5	Configuring Strain Measurements	2-23
2.6	Configuring Acceleration Measurements	2-25
2.7	Configuring Frequency, Revolution, Period, Duty Cycle, Power Supply Frequency, Pulse Width, Pulse Integration, and Velocity Measurements	2-28
2.8	Configuring Logic Signal Measurements	2-34
2.9	Configuring the Monitoring of CAN and CAN FD Bus Signals (/VCE option)	2-36
2.10	Configuring the Monitoring of LIN Bus Signals (/VCE option)	2-42
2.11	Configuring the Monitoring of SENT Signals (/VCE option)	2-46
2.12	Displaying the All Channel Setup Menu	2-50
2.13	Setting the Digital Filter (/G03, /G05 option)	2-55

Chapter 3 Waveform Acquisition

3.1	Setting Conditions for Waveform Acquisition (Scope mode)	3-2
3.2	Setting Conditions for Waveform Acquisition (Recorder mode)	3-4
3.3	Starting and Stopping Waveform Acquisition	3-8
3.4	Using the Dual Capture Feature (Scope mode only)	3-9
3.5	Performing Real-time Recording (SSD Recording) (/ST1 option)	3-13

Chapter 4 Triggering

4.1	Setting the Trigger Mode	4-2
4.2	Setting the Trigger Position, Trigger Delay, Trigger Delay, and Hold-off	4-4
4.3	Triggering on an Edge Trigger (Simple) in Scope Mode	4-5
4.4	Triggering on an Time Trigger (Simple) in Scope Mode	4-7
4.5	Triggering on an External Trigger (Simple)	4-8
4.6	Triggering on a Power Line Signal (Simple)	4-9
4.7	Triggering on a Logic Trigger (Simple)	4-10
4.8	Triggering on an A to B(N) Trigger (Enhanced)	4-11
4.9	Triggering on an A Delay B Trigger (Enhanced)	4-13
4.10	Triggering on an Edge On A Trigger (Enhanced)	4-15

Contents

4.11	Triggering on an OR or AND Trigger (Enhanced) in Scope Mode	4-17
4.12	Triggering on a Period Trigger (Enhanced)	4-19
4.13	Triggering on a Pulse Width Trigger (Enhanced)	4-21
4.14	Triggering on a Wave Window Trigger (Enhanced)	4-23
4.15	Triggering on an Edge Trigger in Recorder Mode	4-25
4.16	Triggering on a Time Trigger in Recorder Mode.....	4-27
4.17	Triggering on an OR or AND Trigger in Recorder Mode	4-28
4.18	Triggering the Instrument Manually (Manual Trigger)	30
 Chapter 5 Display		
5.1	Setting Display Groups and Display Format	5-2
5.2	Setting the Waveform Arrangement, Color, and Grouping.....	5-3
5.3	Setting the Grid and Interpolation Method	5-4
5.4	Configuring the Detailed Display Settings.....	5-6
5.5	Using the Accumulate Feature (Scope mode)	5-9
5.6	Using the Snapshot and Clear Trace Features.....	5-10
 Chapter 6 X-Y display		
6.1	Setting the X-Y Waveform Trace.....	6-2
6.2	Setting the Display Conditions for X-Y Waveforms.....	6-3
6.3	Measuring X-Y Waveforms with Cursors	6-4
 Chapter 7 Zooming In on or Out of Waveforms		
7.1	Zooming In on or Out of Waveforms (Scope mode).....	7-2
7.2	Zooming In on or Out of Waveforms (Recorder mode).....	7-6
 Chapter 8 Searching Waveforms		
8.1	Searching for Edges.....	8-2
8.2	Searching for Events.....	8-5
8.3	Searching for Logic Patterns.....	8-6
8.4	Searching for a Specific Date and Time.....	8-8
 Chapter 9 History Waveform Display/Search (Scope mode only)		
9.1	Displaying Waveform History Waveforms	9-2
9.2	Searching History Waveforms.....	9-4
 Chapter 10 Cursor Measurement		
10.1	Measuring with Horizontal Cursors	10-2
10.2	Measuring with Vertical Cursors.....	10-3
10.3	Measuring with Marker Cursors (Marker).....	10-5
10.4	Measuring with Angle Cursors (Degree)	10-7
10.5	Measuring with Horizontal and Vertical Cursors (H & V).....	10-9
 Chapter 11 Automated Measurement of Waveform Parameters		
11.1	Automatically Measuring Waveform Parameters	11-2
11.2	Performing Continuous Statistical Processing	11-7
11.3	Performing Cyclic Statistical Processing.....	11-8
11.4	Performing Statistical Processing on History Waveforms (Scope mode).....	11-10

Chapter 12 FFT

12.1	Displaying FFT Waveforms	12-2
12.2	Setting the Details of the FFT	12-4
12.3	Measuring FFT Waveforms with Cursors.....	12-8

Chapter 13 Math

13.1	Setting Expressions and Computation Ranges.....	13-2
13.2	Setting the Math Waveform Scaling.....	13-4
13.3	Setting Averaging (/G02 Option)	13-5
13.4	Performing User-Defined Math (/G02 option)	13-7

Chapter 14 GO/NO-GO Determination (Scope mode only)

14.1	Performing GO/NO-GO Determination with Waveform Zones.....	14-2
14.2	Performing GO/NO-GO Determination with Waveform Parameters	14-5

Chapter 15 Actions

15.1	Setting Actions	15-2
------	-----------------------	------

Chapter 16 Real Time Math (/G03, /G05 option)

16.1	Configuring Real Time Math.....	16-2
16.2	Configuring with the All Channel Setup Menu.....	16-20



Chapter 17 Power Math (/G5 option)

17.1	Power Analysis (Power)	17-2
17.2	Harmonic Analysis (Harmonics).....	17-8

Chapter 18 Printing and Saving Screen Captures

18.1	Printing on a Network Printer	18-2
18.2	Printing on a USB Printer	18-3
18.3	Saving Screen Captures to Files.....	18-4

Chapter 19 Saving and Loading Data

 19.1	Connecting a Storage Device	19-2
 19.2	Internal Storage (SSD) (/ST1 option)	19-6
19.3	Formatting a Storage Device	19-7
19.4	Saving Waveform Data	19-9
19.5	Saving Setup Data	19-16
19.6	Saving Other Types of Data	19-17
19.7	Loading Waveform Data.....	19-19
19.8	Loading Setup Data	19-20
19.9	Loading Other Types of Data	19-21
19.10	Performing File Operations	19-23

Chapter 20 Ethernet Communication

20.1	Connecting the Instrument to a Network.....	20-2
20.2	Configuring the TCP/IP Settings	20-5
20.3	Accessing the Instrument from a PC (FTP Server).....	20-7
20.4	Monitoring the Instrument's Display from a PC (Web Server).....	20-8
20.5	Connecting to a Network Drive	20-9
20.6	Configuring Mail Transmission (SMTP client function).....	20-10
20.7	Using SNTP to Set the Date and Time.....	20-11
20.8	Configuring a Network Printer	20-12

Chapter 21 Time Synchronization

21.1	Setting Time Synchronization Mode.....	21-2
21.2	Configuring Master Settings (/C40 option)	21-4

Chapter 22 Connecting Multiple Instruments (/C50 option)

22.1	Connecting Multiple Instruments.....	22-2
22.2	Configuring the Multiple-Unit Connection.....	22-5
22.3	Starting and Stopping Waveform Acquisition	22-7

Chapter 23 Other Operations

23.1	Storing and Recalling Setup Data.....	23-2
23.2	Calibrating the Instrument.....	23-4
23.3	Changing the Message, Menu, and USB Keyboard Languages.....	23-5
23.4	Configuring the LCD.....	23-6
23.5	Using the Instrument as a USB Storage Device	23-8
23.6	Configuring the Environment Settings.....	23-9
23.7	Locking the Keys.....	23-12

Index

Chapter 1

Setup

Main Control Areas Used in This Chapter

You can also use the touch panel.

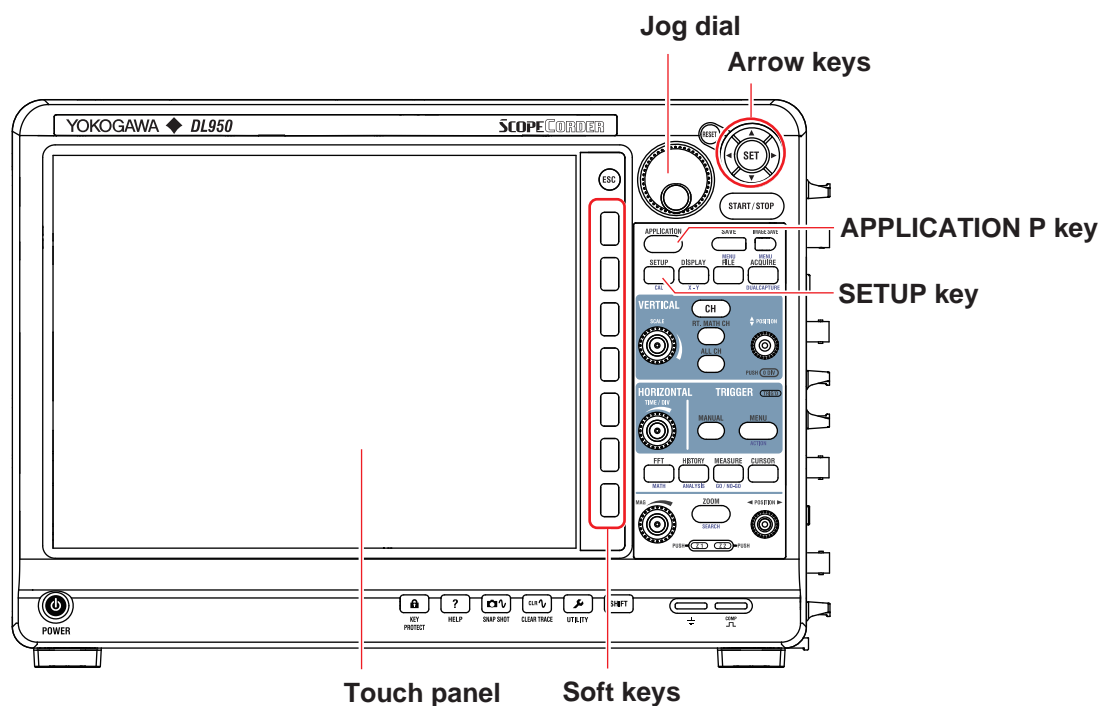

Operation Modes Applicable to the Sections in This Chapter

✓: Applicable, -: Not applicable

Section	Scope Mode	Recorder Mode
1.1 Setting the Operation Mode	✓	✓
1.2 Initializing the Settings	✓	✓
1.3 Performing Auto Setup	✓	✓
1.4 Configuring with the Application Menu	✓	✓

* The settings may vary depending on the operation mode.

1.1 Setting the Operation Mode

This section explains how to set the operation mode.

Items Common to Scope Mode and Recorder Mode

Setting the Operation Mode

- ▶ “Operation Mode (Recorder Mode Switch/Scope Mode Switch)” in the Features Guide

SETUP Screen

1. On the waveform screen’s **MENU**, tap **SETUP** > **SETUP**, or press **SETUP**.

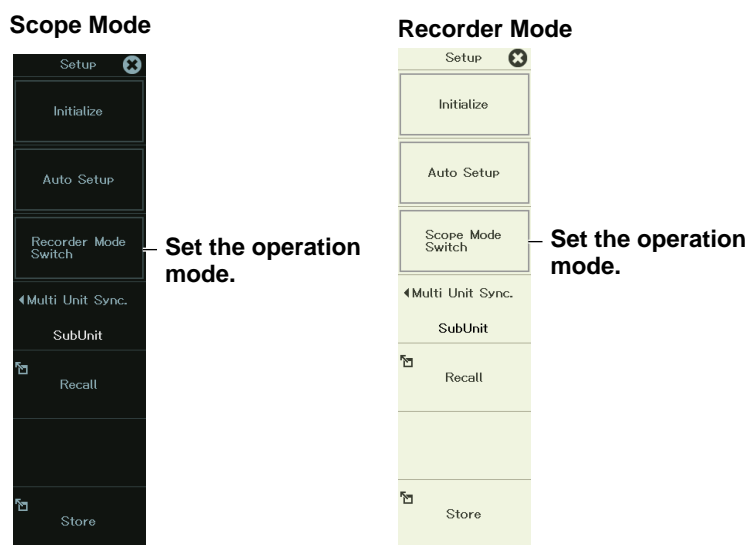

2. To switch from Scope mode to Recorder mode, tap **Recorder Mode Switch**. To switch from Recorder mode to Scope mode, tap **Scope Mode Switch**, or press the corresponding soft key. A confirmation message appears.
3. Tap **OK**, or select **OK** using the arrow keys, and press **SET**.

Scope Mode (Scope Mode)

Scope mode is used to set the time axis using Time/Div and record length. This is the typical time scale setting method for oscilloscopes. The default screen background color (section 5.4) is black.

Recorder Mode

Recorder mode is used to set the time axis using the measurement time and sampling interval. This is the typical time scale setting method for recorders. The default screen background color (section 5.4) is white.

1.2 Initializing the Settings

This section explains how to initialize the settings to their factory default values.

Items Common to Scope Mode and Recorder Mode

Initializing Settings

► [“Initializing Settings to Default \(Initialize\)” in the Features Guide](#)

SETUP Screen

1. On the waveform screen's **MENU**, tap **SETUP** > **SETUP**, or press **SETUP**.

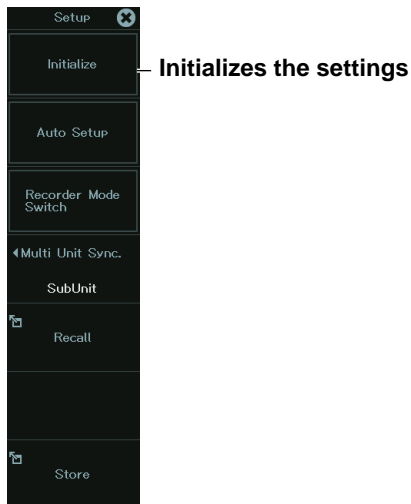

2. Tap **Initialize**, or press the soft key. A confirmation message appears.
3. Tap **OK**, or select **OK** using the arrow keys, and press **SET**. Initialization is executed.

Settings That Cannot Be Reset to Their Factory Default Values

- Date and time settings
- Communication settings
- Language settings
- Operation mode
- Network settings
- Startup state (Standby Startup, Immediate Startup)

1.3 Performing Auto Setup

This section explains how to perform auto setup, which automatically sets the instrument's settings to the values that are most suitable for the input signals.

Items Common to Scope Mode and Recorder Mode

Executing Auto Setup

► [“Auto Setup \(Auto Setup\)” in the Features Guide](#)

SETUP Screen

1. On the waveform screen's **MENU**, tap **SETUP** > **SETUP**, or press **SETUP**.

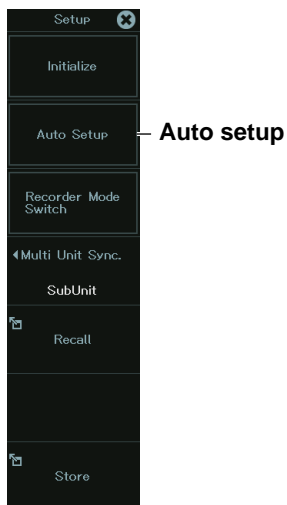

2. Tap **Auto Setup**, or press the soft key. A confirmation message appears.
3. Tap **OK**, or select **OK** using the arrow keys, and press **SET**. Auto setup is executed.

1.4 Configuring with the Application Menu

This section explains how to easily configure the instrument using the measurement applications registered in advance.

Items Common to Scope Mode and Recorder Mode

Configuration on the Application Menu

► “Application (APPLICATION)” in the Features Guide

APPLICATION Menu

1. On the waveform screen's **MENU**, tap **APPLICATION**, or press **APPLICATION**.

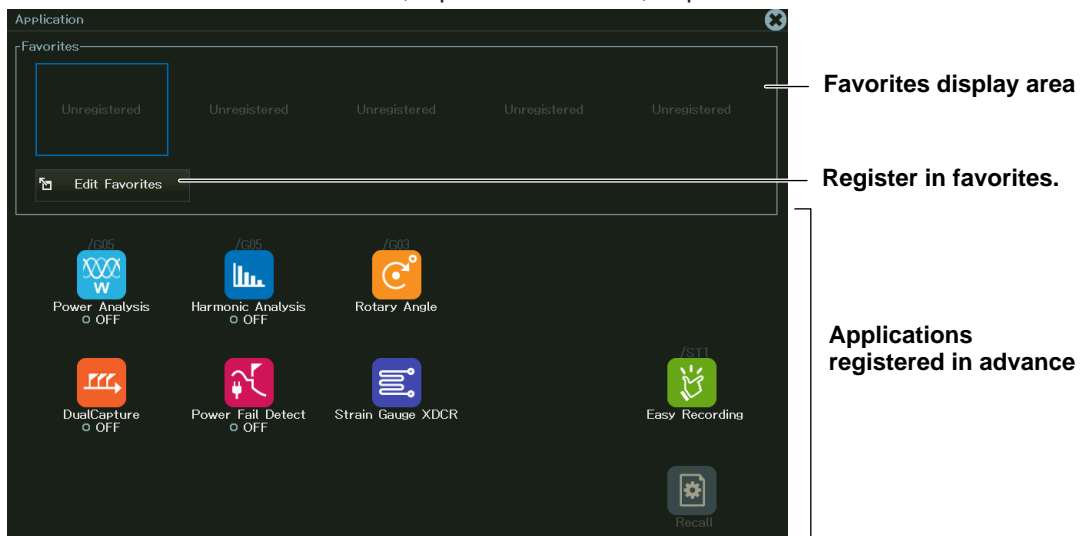

Editing Favorites

2. Tap **Edit Favorites**, or select **Edit Favorites** using the jog dial or arrow keys, and press **SET**. The favorites display area becomes editable.

Registered application

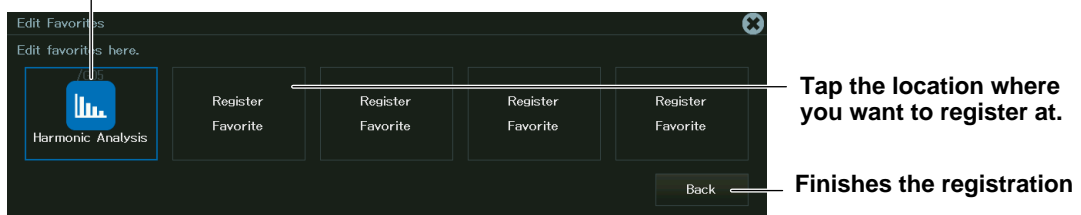

3. Tap a location to register an application to, or select it using the jog dial or arrow keys, and press **SET**. A list of applications appears.

To change an application that is already registered, tap the location where the application is registered, or select it using the jog dial or arrow keys, and press **SET**.

4. Tap the application you want to register, or select it using the jog dial or arrow keys, and press **SET**. The application is registered in favorites.

1.4 Configuring with the Application Menu

5. Tap **Back**, or select **Back** using the jog dial or arrow keys, and press **SET**.

The screen shown in step 1 appears.

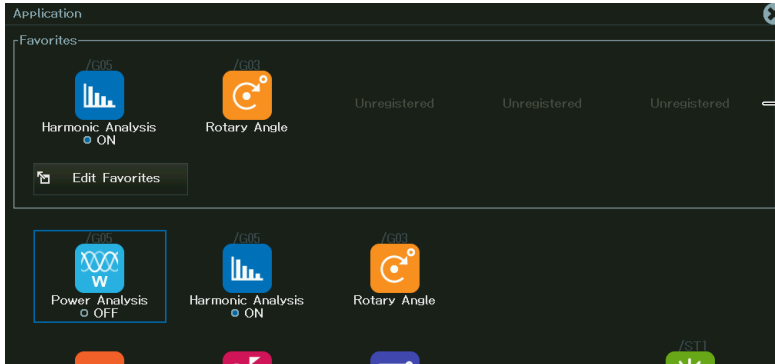

Example in which harmonic analysis and angle-of-rotation calculation applications are registered

How to Use Applications

This section explains how to use typical applications.

2. On the application list or favorites, tap the application you want to edit, or select it using the jog dial or arrow keys, and press **SET**. An application setup screen appears.

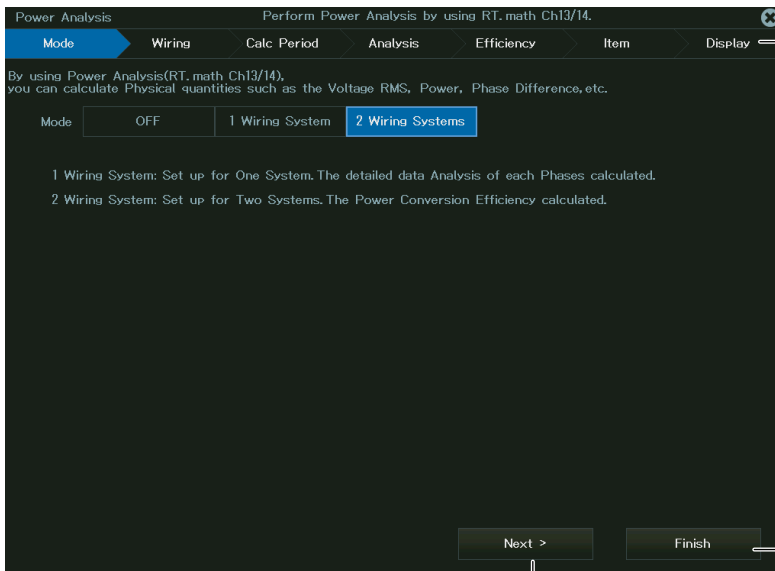

Setup steps
Set from left to right. You can also tap a step you want to set directly.

Setup menu

Finishes the setup

Advances to the next step

Note

Depending on the setup conditions, setup steps that do not need to be configured appear dark and are skipped. Even if you tap a setup step that appears dark, a setup screen will not appear.

3. After entering the displayed setting, to move to the next step, tap **Next**, or select **Next** using the jog dial or arrow keys, and press **SET**.

You can also select a specific setup step by tapping the step you want to set or by selecting the step using the jog dial or arrow keys and pressing **SET**.

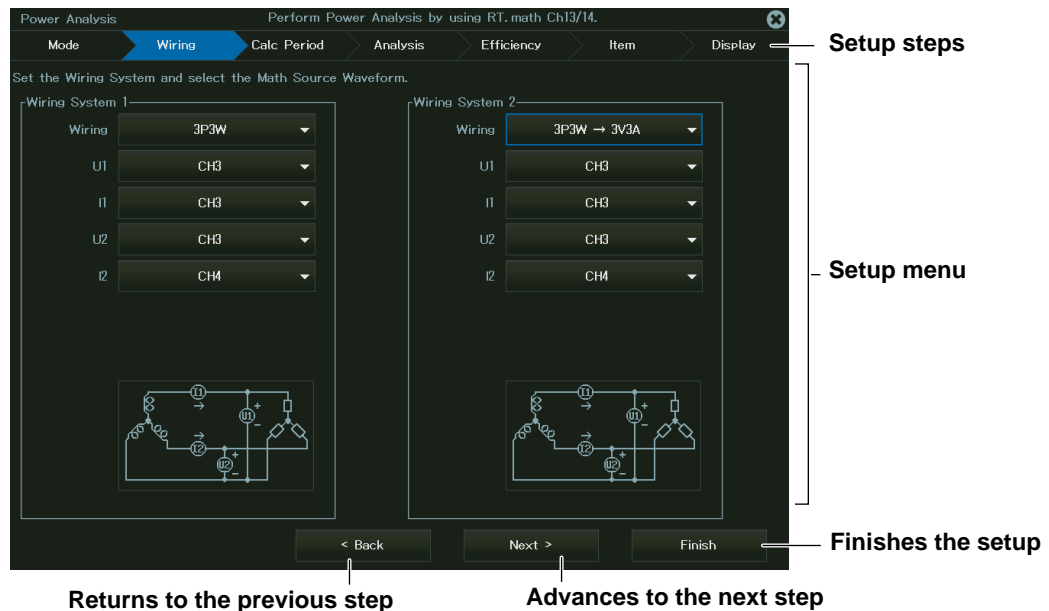

4. After setting the last step, tap **Finish**, or select **Finish** using the jog dial or arrow keys, and press **SET**. The setup is complete.

Setup Details

For details on the settings of each application, see the chapter or section explaining the applicable setup procedure.

Chapter 2

Channel Setup

Main Control Areas Used in This Chapter

You can also use the touch panel.

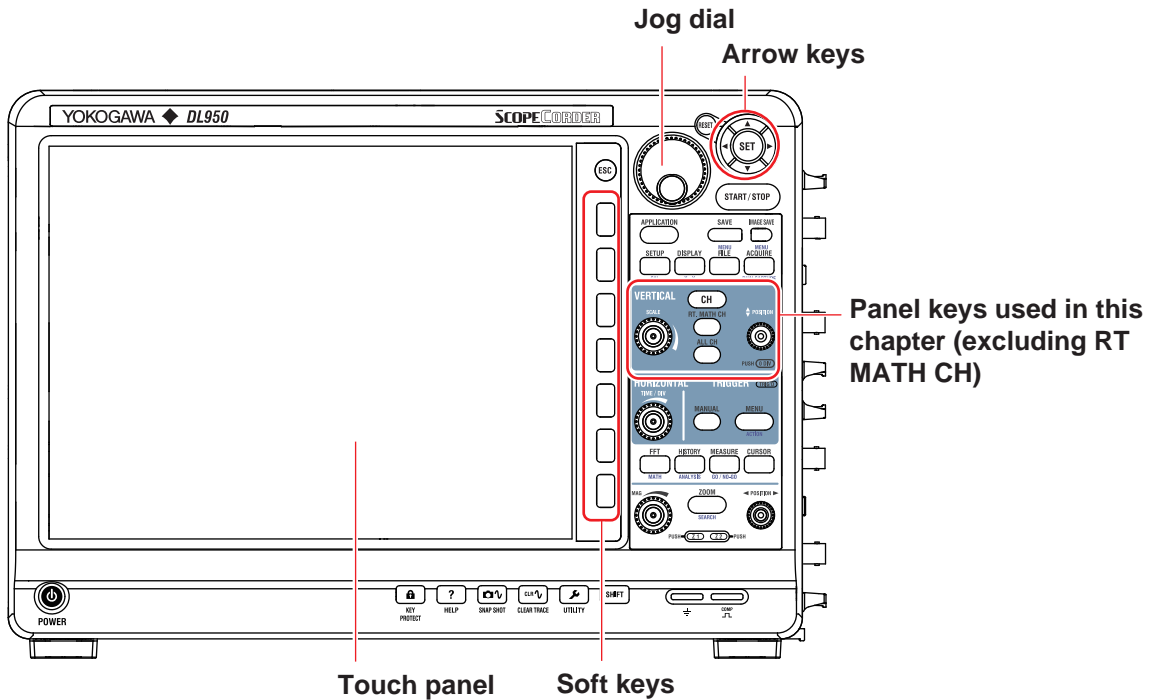

Operation Modes Applicable to the Sections in This Chapter

✓: Applicable, -: Not applicable

Section	Scope Mode	Recorder Mode
2.1 Configuring Voltage Measurements (on modules other than 16-CH temperature/voltage input modules)	✓	✓
2.2 Configuring Voltage Measurements (on 16-CH temperature/voltage input modules)	✓	✓
2.3 Configuring Temperature Measurements (on modules other than 16-CH temperature/voltage input modules)	✓	✓
2.4 Configuring Temperature Measurements (For 16-CH temperature/voltage input modules)	✓	✓
2.5 Configuring Strain Measurements	✓	✓
2.6 Configuring Acceleration Measurements	✓	✓
2.7 Configuring Frequency, Revolution, Period, Duty Cycle, Power Supply Frequency, Pulse Width, Pulse Integration, and Velocity Measurements	✓	✓
2.8 Configuring Logic Signal Measurements	✓	✓
2.9 Configuring the Monitoring of CAN and CAN FD Bus Signals (/VCE option)	✓	✓
2.10 Configuring the Monitoring of LIN Bus Signals (/VCE option)	✓	✓
2.11 Configuring the Monitoring of SENT Signals (/VCE option)	✓	✓
2.12 Displaying the All Channel Setup Menu	✓	✓
2.13 Setting the Digital Filter (/G03, /G05 option)	✓	✓

* The settings may vary depending on the operation mode.

2.1 Configuring Voltage Measurements (on modules other than 16-CH temperature/voltage input modules)

This section explains the following settings for voltage measurements:

Scope Mode

- Turning waveform input on and off
- Display label
- Input coupling
- Probe attenuation and current-to-voltage conversion ratio
- Filter (bandwidth limit, digital filter)
- Display setup (display group)
- Zoom method (DIV/SPAN) switching
- Vertical zoom (vertical zoom, offset), upper and lower display range limits
- Adjustment (DC offset cancellation, gain adjustment)
- Turning the inverted waveform display on and off
- Sample rate
- Linear scaling
- Vertical scale (V/div)
- Vertical position

Recorder Mode

- Turning waveform input on and off
- Display label
- Input coupling
- Probe attenuation and current-to-voltage conversion ratio
- Filter (bandwidth limit, digital filter)
- Display setup (display group)
- Upper and lower limits of the display range
- Adjustment (DC offset cancellation, gain adjustment)
- Turning the inverted waveform display on and off
- Sample interval
- Linear scaling
- Measurement range

► [“Voltage Measurement” in the Features Guide](#)

Channel Setup Menu

1. On the waveform screen's **MENU**, tap **VERTICAL** > **CH**, or press **CH**. A channel setup menu appears.

You can also tap the channel information display area at the top of the screen to display the channel setup menu.

2. Tap a channel you want to configure, or select it using the jog dial or up and down arrow keys. For a 4-CH module (720254 (4CH 1M16) or 720256 (4CH 10M16)), select a sub channel (a channel number followed by an underscore and a number as in CH3_1 if the display label is set to default).

Scope Mode

Channel Setup Menu on /G03 and /G05 models (1/2) (excluding 720254 and 720256)

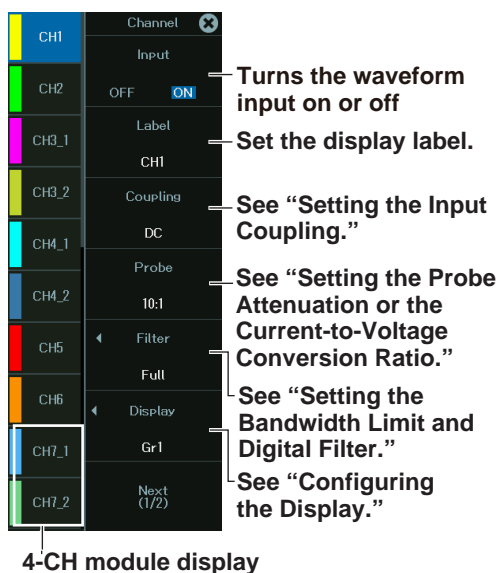

Channel Setup Menu on models other than /G03 and /G05 models (1/2) (Including the 720254 and 720256 on /G03 and /G05 models)

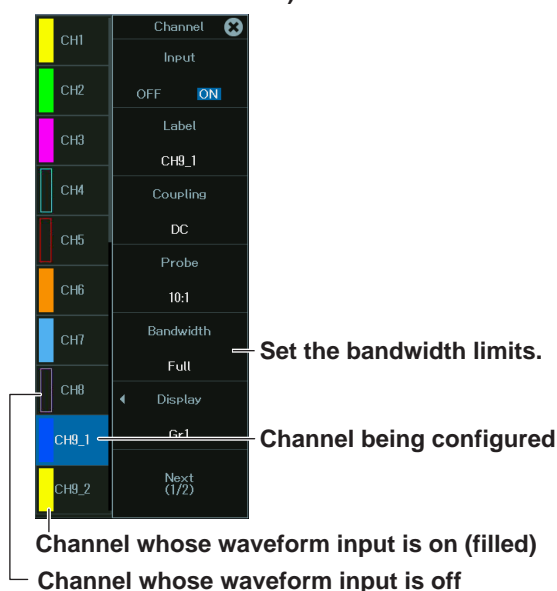

Channel setup menu (2/2)

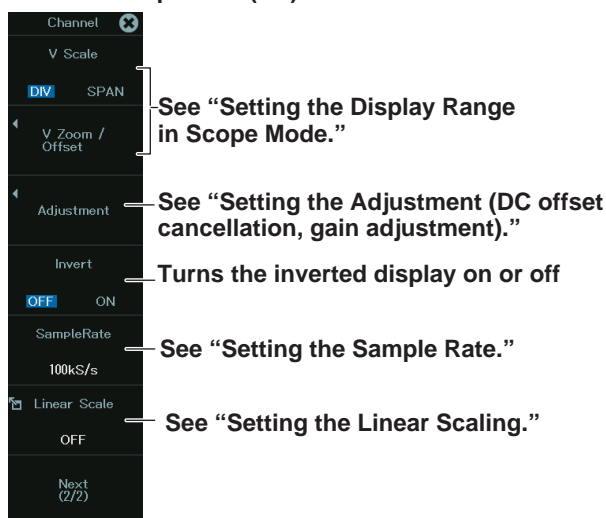

2.1 Configuring Voltage Measurements (on modules other than 16-CH temperature/voltage input modules)

Recorder Mode

Channel Setup Menu on /G03 and /G05 models (1/2) (excluding the 720254 and 720256)

CH1	Channel	✕
	Input	
CH2	OFF	ON
	Label	
CH3	CH1	
	Coupling	
CH5	DC	
CH6	Probe	
CH7	10:1	
	Filter	
CH8	Full	
	Display	
CH9	Gr1	
CH10		
CH11	Next (1/2)	

— Turns the waveform input on or off

— Set the display label.

— See “Setting the Input Coupling.”

— See “Setting the Probe Attenuation or the Current-to-Voltage Conversion Ratio.”

— See “Setting the Bandwidth Limit and Digital Filter.”

— See “Configuring the Display.”

Channel Setup Menu on models other than /G03 and /G05 models (1/2) (Including the 720254 and 720256 on /G03 and /G05 models)

CH1	Channel	✕
	Input	
CH2	OFF	ON
	Label	
CH3	CH1	
	Coupling	
CH5	DC	
CH6	Probe	
CH7	10:1	
	Bandwidth	
CH8	Full	
	Display	
CH9	Gr1	
CH10		
CH11	Next (1/2)	

— Set the bandwidth limits.

Channel setup menu (2/2)

Channel	✕
Upper/Lower	250.0V - 250.0V
Adjustment	
Invert	OFF ON
Sample Interval	10us
Linear Scale	OFF
	Next (2/2)

— See “Setting the Display Range in Recorder Mode.”

— See “Setting the Adjustment (DC offset cancellation, gain adjustment).”

— Turns the inverted display on or off

— See “Setting the Sample Interval.”

— See “Setting the Linear Scaling.”

Setting the Input Coupling

The following figure shows the frequency characteristics when the input coupling is set to AC or DC.

Please note that when set to AC, the instrument does not acquire low frequency signals or low frequency components, as seen in the following figure.

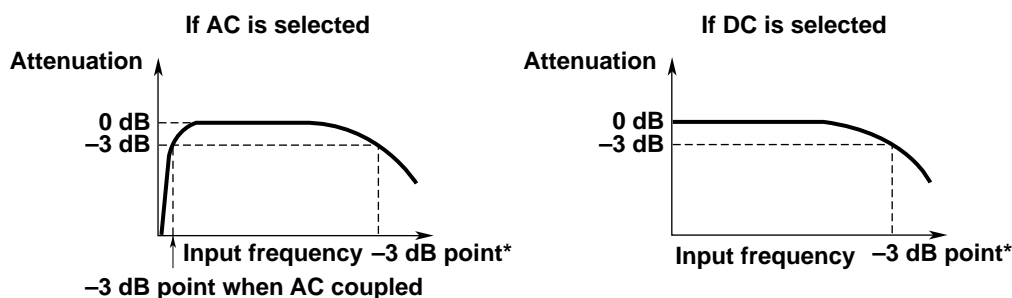

* This value differs depending on the input module.
For details, section 7.15, "Module Specifications," in the Getting Started Guide (IM DL950-03EN).



CAUTION

If the input coupling is AC, in accordance with the frequency response, the input signal is attenuated more in lower frequencies. As a result, even when a high voltage signal is actually applied, it may not be measured as a high voltage signal. Furthermore, the over-range indicator may not be displayed on the instrument screen. As necessary, switch the input coupling to DC to check the input signal voltage.

Applying an input signal whose voltage exceeds the maximum input voltage of the input module may damage the input section.

French



ATTENTION

Si le courant du couplage d'entrée est alternatif (CA), conforme à la réponse en fréquence, le signal d'entrée est davantage atténué aux fréquences plus basses. Par conséquent, même si vous appliquez un signal de tension élevée, ce dernier risque de ne pas être mesuré comme tel. De plus, le voyant de dépassement de plage risque de ne pas s'afficher à l'écran. Le cas échéant, basculez le couplage d'entrée sur CC (courant continu) afin de vérifier la tension du signal d'entrée.

Si la tension du signal d'entrée dépasse la tension d'entrée maximale du module d'entrée, la section d'entrée risque d'être endommagée.

Setting the Probe Attenuation or the Current-to-Voltage Conversion Ratio

Voltage probe's attenuation ratio

1:1, 10:1, 100:1, 1000:1

Current probe's current-to-voltage conversion ratio

1A:1V (1V/A), 2A:1V (0.5V/A), 5A:1V (0.2V/A), 10A:1V (0.1V/A), 20A:1V (0.05V/A), 50A:1V (0.02V/A), 100A:1V (0.01V/A), 200A:1V (5mV/A), 400A:1V (2.5mV/A), 500A:1V (2mV/A), 1kA:1V (1mV/A), 2kA:1V (0.5mV/A), 5kA:1V (0.2mV/A), 10kA:1V (0.1mV/A), 20kA:1V (0.05mV/A), 50kA:1V (0.02mV/A)

Note

If the probe attenuation or current-to-voltage conversion ratio is not set correctly, the voltage and scale values of the input signals will not be displayed correctly. For example, if you use a 10:1 voltage probe but set the probe type to 1:1, the automatically measured amplitude of the waveform will be 1/10 the real value.

Setting the Bandwidth Limit and Digital Filter (Filter /G03, /G05 option)

You only need to set the bandwidth limit on channels in which 720254 or 720256 input modules are installed.

3. After step 2 on page 2-3, tap **Filter**, or press the soft key. A filter setup menu appears.

Note

For channels in which a 720254 or 720256 is installed, tap **Bandwidth**, or press the soft key to set the bandwidth limit.

Setting the low-pass filter (LPF)

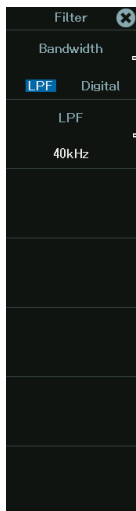

Set the bandwidth limit to LPF.

Set the bandwidth. (The available bandwidths vary depending on the module.)

Setting the digital filter (Digital)

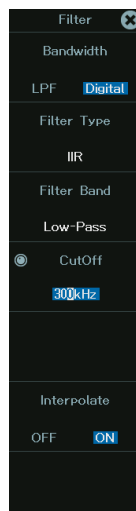

Set the bandwidth limit to Digital.

Set the filter type. (Gauss/Sharp/IIR/Mean/IIR-Lowpass)

Turns interpolation on or off

Setting the Filter Type (Filter Type)

Setting the Gauss, Sharp, IIR, or IIR-Lowpass Filter

4. Set **Bandwidth** to **Digital**.
5. Tap **Filter Type**, or press the soft key. A Filter Type setup menu appears.

When Filter Band is set to Low-Pass or High-Pass

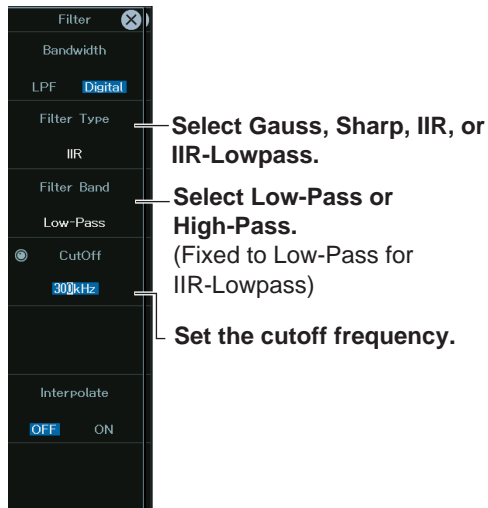

When Filter Band is set to Band-Pass

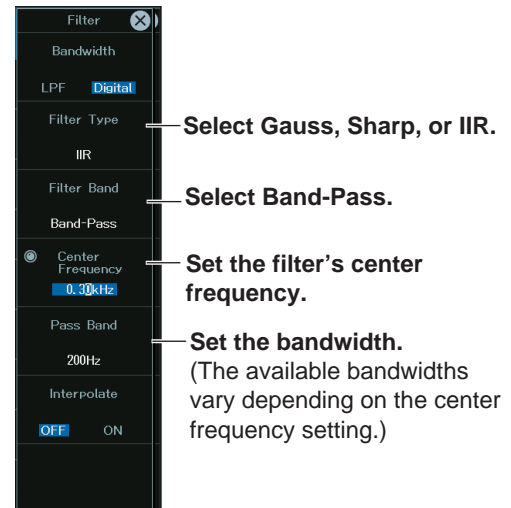

For Band-Pass, set the center frequency and the bandwidth, the frequencies before and after the center frequency.

Setting the Moving Average (Mean)

4. Set **Filter Type** to **Mean**.

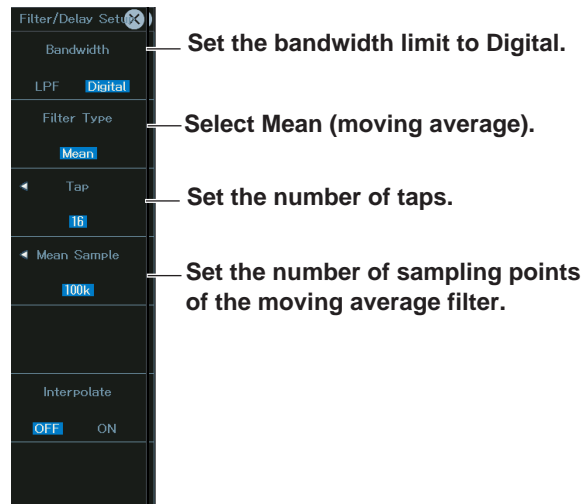

Configuring the Display (Display)

- After step 2 on page 2-3, tap **Display**, or press the soft key. A display setup menu appears.



Set the display group in which the channel you are setting is to be registered. You can register a channel in multiple display groups. For details on configuring display groups, see chapter 5, “Display.”

Setting the Display Range and Scope Mode (V Scale, V Zoom/Offset, Upper/ Lower)

Using DIV

- After step 2 on page 2-3, set **V SCALE** to **DIV**.
- Tap **V Zoom/Offset**, or press the soft key.



Using Span

- After step 2 on page 2-3, set **V SCALE** to **SPAN**.
- Tap **Upper/Lower**, or press the soft key.

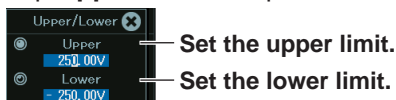

For the upper and lower limits, if you tap the jog dial mark several times or press SET to select both Upper and Lower marks to be changed with the jog dial, you can change the upper in the lower limits while keeping the interval between them constant.

Note

- The display range V/div is displayed above the measurement range V/div. This is not displayed when the V Scale is set to DIV and the magnification is x1 because the display range is the same as the measurement range.



- When V Scale is set to DIV, the display range is set in integer multiples of V/div. Therefore, the display range changes according to the changes in V/div.
- When V Scale is set to SPAN, the display range is fixed. Therefore, the display range does not change even if V/div is changed.

Setting the Display Range in Recorder Mode (Upper/Lower)

3. After step 2 on page 2-3, tap **Upper/Lower**, or press the soft key.

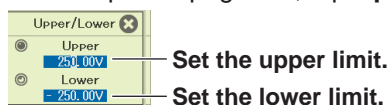

Note

The upper and lower limits cannot exceed 10 times the measurement range. If changing the measurement range causes the upper and lower limits to exceed 10 times the measurement range, the upper and lower limits are automatically adjusted.

Setting the Adjustment (DC offset cancellation, gain adjustment)

3. After step 2 on page 2-3, tap **Adjustment**, or press the soft key.

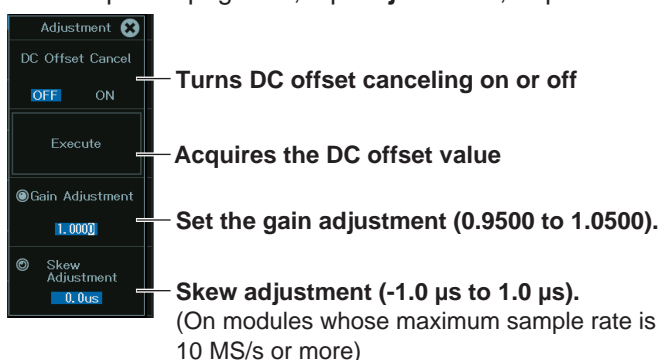

Note

- When DC offset canceling is set to ON, you cannot adjust the gain.
- When gain adjustment is enabled, DC offset canceling cannot be set to ON. If you acquire the DC offset value when gain adjustment is enabled, gain adjustment will be disabled, and DC offset canceling will be set to ON.

Setting the Sample Rate (SampleRate, Scope mode)

In Scope mode, you can set the sample rate for each channel.

You can set the sample rate as high as the sample rate determined by the display record length and T/div settings in the waveform acquisition conditions.

If the sample rate determined by the display record length and T/div settings exceeds the maximum sample rate of a module, you can set the sample rate as high as the maximum sample rate of that module.

For example, if modules with sample rates at 10 MS/s or higher are installed and the sample rate determined by the display record length and T/div settings exceeds the maximum sample rate of a module, you can set the sample rate as high 10 MS/s.

This is useful when you do not want to acquire unneeded data.

Setting the Sample Interval (Sample Interval, Recorder mode)

In Recorder mode, you can set the sample interval for each channel.

You can set the sample interval as high as the sample interval set on the Acquire menu.

This is useful when you do not want to acquire unneeded data.

Setting the Linear Scaling (Linear Scale)

- After step 2 on page 2-3, tap **Linear Scale**, or press the soft key.

When setting the slope and offset of the equation (AX+B)

The screenshot shows the 'Linear Scale' menu with the following settings and annotations:

- Scaling Mode:** OFF, **AX+B** (selected), P1-P2. *Annotation: Select AX+B.*
- A:** 25.000. *Annotation: Set the scaling coefficient.*
- B:** -25.000. *Annotation: Set the offset.*
- Unit:** [Empty field]. *Annotation: Set the unit.*
- Display Type Mode:** Exponent, **Floating** (selected). *Annotation: Set the numeric display format (Exponent).*

A second screenshot shows the 'Display Type' sub-menu with the following settings and annotations:

- Mode:** Exponent, **Floating** (selected). *Annotation: Set the numeric display format (Floating).*
- Decimal Number:** Auto. *Annotation: Set the number of decimal places.*
- Sub Unit:** Auto. *Annotation: Set the unit prefix.*

When setting two points (P1-P2)

The screenshot shows the 'Linear Scale' menu with the following settings and annotations:

- Scaling Mode:** OFF, AX+B, **P1-P2** (selected). *Annotation: Select P1-P2.*
- P1[X]:** 1.0000. *Annotation: Measurement values*
- P1[Y]:** 0.0000. *Annotation: Set the P1 X value to the current measured value.*
- P2[X]:** 5.0000. *Annotation: Scale value of measurement P1*
- P2[Y]:** 100.00. *Annotation: Set the P2 X value to the current measured value.*
- Unit:** [Empty field]. *Annotation: Scale value of measurement P2*
- Display Type Mode:** Exponent, Floating. *Annotation: Set the numeric display format.*

Setting the Vertical Scale (SCALE knob) (Scope mode)

- After step 2 on page 2-3, select a channel, and then turn the SCALE knob to set the vertical scale.

If you turn the SCALE knob while the acquisition is stopped, the new vertical scale is applied the next time you start waveform acquisition.

Setting the Measurement Range (SCALE knob) (Recorder mode)

- After step 2 on page 2-3, select a channel, and then turn the SCALE knob to set the measurement range.

If you turn the SCALE knob while the acquisition is stopped, the new vertical scale is applied the next time you start waveform acquisition.

Note

If changing the measurement range causes the upper and lower limits to exceed 10 times the measurement range, the upper and lower limits are automatically adjusted so that 10 times the measurement range is not exceeded.

Setting the Vertical and Horizontal Positions of Waveforms (moving displayed waveforms)

Scope Mode

- After step 2 on page 2-3, select a channel, and then vertically drag near the center of the screen displaying the waveform of the selected channel to display up and down arrows. Tap the arrows to move the waveform. The arrows disappear after a given time period.

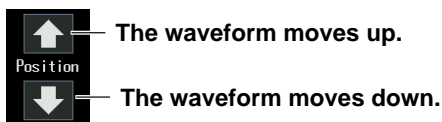

When V SCALE is set to DIV in Scope mode, select a channel, and then turn the vertical POSITION knob to set the vertical position.

Recorder Mode

- After step 2 on page 2-3, select a channel, and then vertically drag near the center of the screen displaying the waveform of the selected channel to display up and down arrows or drag horizontally to display left and right arrows. You can move the vertical or horizontal position by performing the following operation while the arrows are displayed.

Drag the screen to display:

Drag vertically.

Up and down arrows

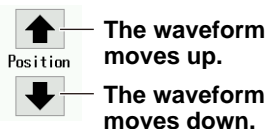

Drag horizontally.

Left and right arrows

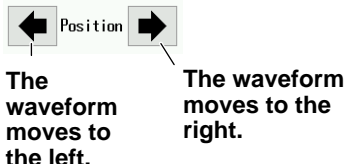

Tap the screen to display:

Tap here to expand the time range of the waveform display.

Displays the waveform at the left edge of the acquisition time or record time bar

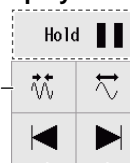

When waveform acquisition is in progress, Hold or Resume is displayed here.

Tap here to reduce the time range of the waveform display.

Displays the waveform at the right edge of the acquisition time or record time bar

2.2 Configuring Voltage Measurements (on 16-CH temperature/voltage input modules)

This section explains the following voltage measurement settings for the 16-CH temperature/voltage input module:

Scope Mode

- Turning waveform input on and off
- Display update rate
- All sub channel settings
(Display label, input coupling, zoom method (DIV/SPAN) switching, vertical zoom (vertical zoom, offset), upper and lower display range limits, linear scaling)
- Display setup (display group)
- Zoom method (DIV/SPAN) switching
- Vertical zoom (vertical zoom, offset), upper and lower display range limits
- Turning the inverted waveform display on and off
- Sample rate
- Linear scaling
- Vertical scale (V/div)
- Vertical position

Recorder Mode

- Turning waveform input on and off
- Display update rate
- All sub channel settings
(Display label, input coupling, measurement range, upper and lower display range limits, linear scaling)
- Display setup (display group)
- Upper and lower limits of the display range
- Turning the inverted waveform display on and off
- Sample interval
- Linear scaling
- Measurement range

► [“Voltage Measurement” in the Features Guide](#)

Channel Setup Menu

1. On the waveform screen's **MENU**, tap **VERTICAL** > **CH**, or press **CH**. A channel setup menu appears.
(You can also tap the channel information display area at the top of the screen to display the channel setup menu.)
2. Tap a channel you want to configure, or select it using the jog dial or up and down arrow keys.

Scope Mode

Channel setup menu (1/2)

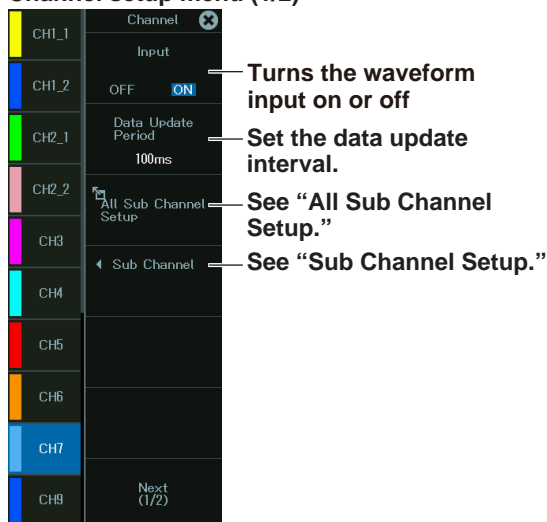

Channel setup menu (2/2)

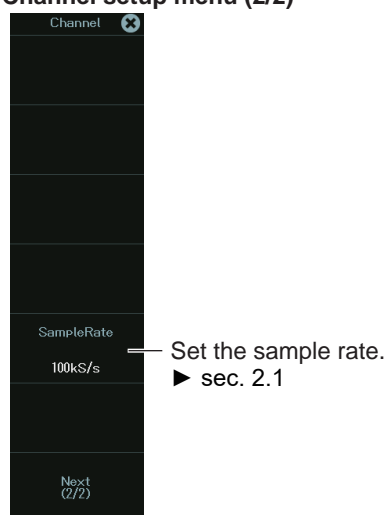

Recorder Mode

Channel setup menu (1/2)

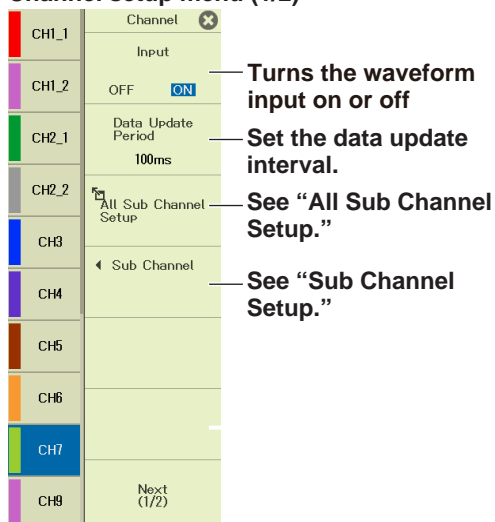

Channel setup menu (2/2)

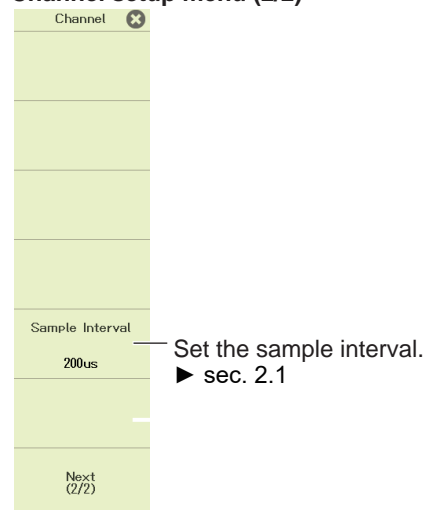

All Sub Channel Setup (All Sub Channel Setup)

3. Tap **All Sub Channel Setup**, or press the soft key. An All Sub Channel Setup screen appears.
4. Tap **Setup**, or press the soft key.

When measuring voltage, set the input coupling to DC or GND.

Scope Mode

	Label	Coupling	V Scale	DIV/Scale	Offset	Position	V Zoom
All		DC	200mV	SPAN	20000.0mV	-20000.0mV	
1	CH3_1	DC	200mV	DIV	0.0mV	0.00div	x 1
2	CH3_2	DC	200mV	SPAN	20000.0mV	-20000.0mV	
3	CH3_3	DC	50mV	DIV	0.00mV	0.00div	x 2
4	CH3_4	TC	K	°C	1300.0C	- 200.0C	ON OFF
5	CH3_5	DC	200mV	DIV	0.0mV	0.00div	x 1
6	CH3_6					0.00div	x 1
7	CH3_7					0.00div	x 1
8	CH3_8	DC	200mV	DIV	0.0mV	0.00div	x 1
9	CH3_9	DC	200mV	DIV	0.0mV	0.00div	x 1

When the vertical scale is set to SPAN, the settings for Offset, Position, V and Zoom change to Upper and Lower.

Recorder Mode

	Label	Coupling	V Scale	Upper	Lower
All		DC	2V	20.0V	- 20.0V
1	CH5_1	DC	2V	20000.0mV	-20000.0mV
2	CH5_2	DC	2V	20000.0mV	-20000.0mV
3	CH5_3	DC	2V	20000.0mV	-20000.0mV
4	CH5_4	DC	2V	20000.0mV	-20000.0mV
5	CH5_5				
6	CH5_6				
7	CH5_7	DC	2V	20000.0mV	-20000.0mV
8	CH5_8	DC	2V	20000.0mV	-20000.0mV
9	CH5_9	DC	2V	20000.0mV	-20000.0mV

Note

You cannot turn on and off the waveform input at the sub channel level.

Setting the Linear Scaling (Linear Scale)

5. Tap **Linear Scale**, or press the soft key. A linear scaling setup screen appears. For details on the settings, see “Linear Scaling” in section 2.1.
6. Tap the items of each sub channel. Use the displayed list (options) or input box to set the items.

Linear scaling mode

Scaling coefficient A or measured value at point P1
 Offset value B or scaled value of point P1
 Measurement value of point P2
 Scaled value of point P2
 Unit
 Display mode
 Number of decimal places
 Unit prefix

Linear Scale	AX+B: A P1-P2	AX+B: B P1×P1-P2	P1-Y	P1-P2	P2×P1-P2	P2-Y	Unit	Disp Type	Decim Num	Sub Unit
All	OFF									
1	AX+B	25.000	-25.000					Float	Auto	Auto
2	AX+B	25.000	-25.000					Exp		
3	P1-P2	1.0000	0.0000	5.0000	100.00			Float	Auto	Auto
4	P1-P2	1.0000	0.0000	5.0000	100.00	mm/s		Exp		
5	OFF									
6	OFF									
7	OFF									
8	OFF									
9	OFF									

To set all the sub channels to the same setting, change the settings in the All row.

Slide to display channels that do not fit in the screen.

See “Copying Channels.”

Copying Channels (Copy to)

7. Tap **Copy to**, or press the soft key. The following screen appears.

Select the source sub channel.

Press to select all sub channels.

Press to clear all sub channels.

Select the sub channels that you want to copy to.

Starts copying

The setup and linear scale settings are copied.

Sub Channel Setup (Sub Channel)

3. Tap **Sub Channel**, or press the soft key. A sub channel setup screen appears.

Scope Mode

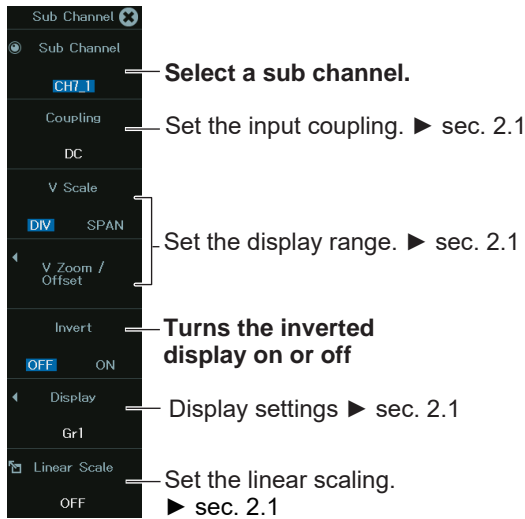

Recorder Mode

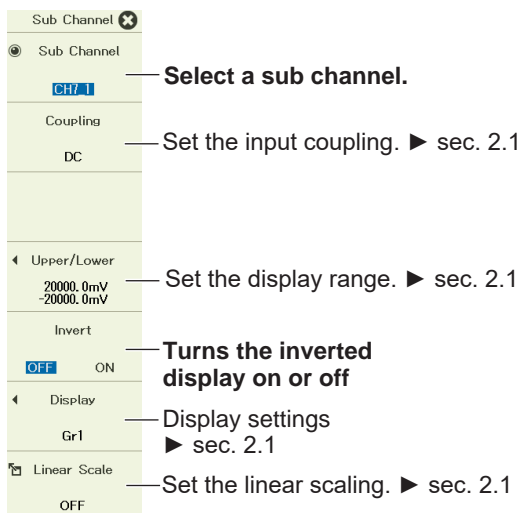

Setting the Vertical Scale (SCALE knob) (when V SCALE is set to DIV in Scope mode)

▶ section 2.1

Setting the Measurement Range (SCALE knob) (Recorder mode, when V SCALE (vertical scale) is set to SPAN in Scope mode)

▶ section 2.1

Setting the Waveform Vertical and Horizontal Positions (Sliding the waveform screen)

▶ section 2.1

2.3 Configuring Temperature Measurements (on modules other than 16-CH temperature/voltage input modules)

This section explains the following settings for temperature measurements:

Items Common to Scope Mode and Recorder Mode

- Turning waveform input on or off
- Display label
- Input coupling
- Thermocouple type
- Filter (bandwidth limit, digital filter)
- Display setup (display group)
- Upper and lower limits of the display range
- Temperature unit
- Sample Rate and Sample Interval
- Temperature settings (RJC, burnout on/off, Bmode, attenuator settings)

► [“Temperature Measurement” in the Features Guide](#)

Channel Setup Menu

1. On the waveform screen’s **MENU**, tap **VERTICAL > CH**, or press **CH**. A channel setup menu appears.
(You can also tap the channel information display area at the top of the screen to display the channel setup menu.)
2. Tap a channel you want to configure, or select it using the jog dial or up and down arrow keys.

Channel setup menu (1/2)

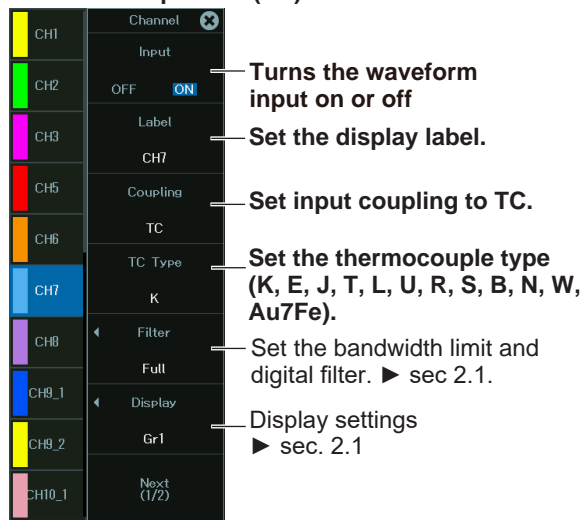

Channel setup menu (2/2)

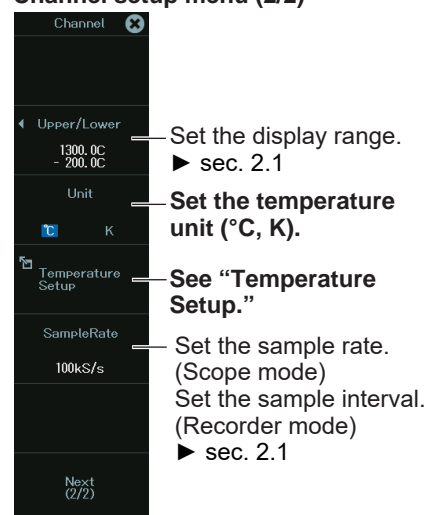

Temperature Setup (Temperature Setup) (RJC, burnout on/off)

1. Tap **Temperature Setup**, or press the soft key. The following screen appears.

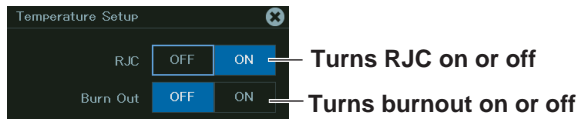

Setting the Waveform Vertical and Horizontal Positions (Sliding the waveform screen)

- ▶ section 2.1

2.4 Configuring Temperature Measurements (For 16-CH temperature/voltage input modules)

This section explains the following temperature measurement settings for the 16-CH temperature/voltage input module:

Items Common to Scope Mode and Recorder Mode

- Turning waveform input on or off
- Data update interval
- All sub channel settings
(Display label, input coupling, thermocouple type, unit, upper and lower display range limits, RJC, burnout)
- Display setup (display group)
- Upper and lower limits of the display range
- Unit
- Temperature Setup (RJC, burnout)
- Sample Rate and Sample Interval
 - ▶ [“Temperature Measurement \(For the 16-CH Temperature/Voltage Input Module\)” in the Features Guide](#)

Channel Setup Menu

1. On the waveform screen’s **MENU**, tap **VERTICAL** > **CH**, or press **CH**. A channel setup menu appears.
(You can also tap the channel information display area at the top of the screen to display the channel setup menu.)
2. Tap a channel you want to configure, or select it using the jog dial or up and down arrow keys.

Channel setup menu (1/2)

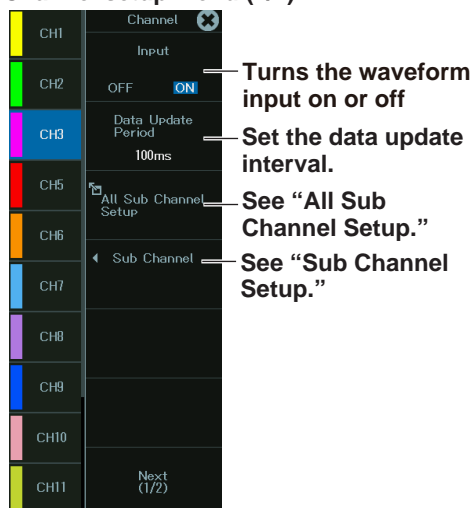

Channel setup menu (2/2)

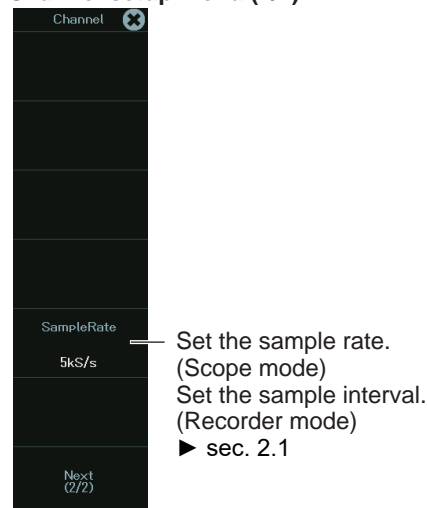

All Sub Channel Setup (All Sub Channel Setup)

3. Tap **All Sub Channel Setup**, or press the soft key. An All Sub Channel Setup screen appears.

Annotations for the All Sub Channel Setup screen:

- Set input coupling to TC.** (Points to Coupling column)
- Thermocouple type** (Points to Type column)
- Set the upper limit.** (Points to Upper column)
- Set the lower limit.** (Points to Lower column)
- Turns RJC on or off** (Points to RJC column)
- Turns burnout on or off** (Points to Burn column)
- Display label** (Points to Label column)
- Unit (°C, K)** (Points to Unit column)

	Label	Coupling	Type	Unit	Upper	Lower	RJC	Burn
All		TC	K	°C	1300	- 200.0C	OFF	ON
1	CH3_1	TC	K	°C	1300.0C	- 200.0C	OFF	ON
2	CH3_2	TC	T	°C	400.0C	- 250.0C	ON	OFF
3	CH3_3	TC	K	°C	1300.0C	- 200.0C	ON	OFF
4	CH3_4	TC	R	°C	1700.0C	0.0C	ON	OFF
5	CH3_5	DC	200mV	DIV	0.0mV	0.00div	× 1	
6	CH3_6					00div	× 1	
7	CH3_7					00div	× 1	
8	CH3_8	TC	K	°C	1300.0C	- 200.0C	ON	OFF
9	CH3_9	TC	K	°C	1300.0C	- 200.0C	ON	OFF

Additional annotations:

- Slide to display channels that do not fit in the screen.** (Points to a scroll bar on the left)
- The displayed items vary depending on the input coupling and vertical scale settings of the selected sub channel.** (Points to the right-hand side of the screen)
- Sub channels of temperature measurement are not applicable.** (Points to rows 6 and 7)
- To set all the sub channels to the same setting, change the settings in the All row.** (Points to the 'All' row)
- See "Copying Channels."** (Points to the 'Copy to' button)

Copying Channels (Copy to)

4. Tap **Copy to**, or press the soft key. The following screen appears.

Annotations for the Copy to screen:

- Select the source sub channel.** (Points to the Source Sub Channel dropdown menu)
- Press to select all sub channels.** (Points to the All ON button)
- Press to clear all sub channels.** (Points to the All OFF button)
- Select the sub channels that you want to copy to.** (Points to the grid of sub channel checkboxes)
- Starts copying** (Points to the Execute button)

The setup and linear scale settings are copied.

Sub Channel Setup (Sub Channel)

3. Tap **Sub Channel**, or press the soft key. An Sub Channel screen appears.

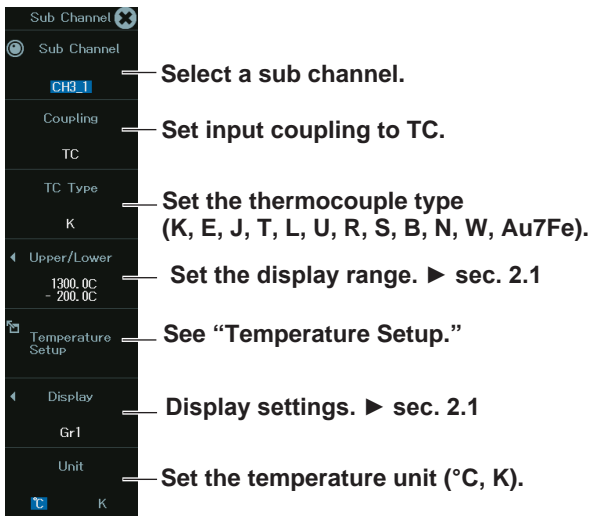

Temperature Setup (Temperature Setup) (RJC, burnout on/off)

4. Tap **Temperature Setup**, or press the soft key. The following screen appears.

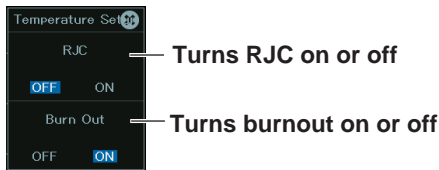

Setting the Waveform Vertical and Horizontal Positions (Sliding the waveform screen)

- ▶ section 2.1

2.5 Configuring Strain Measurements

This section explains the following settings for strain measurements:

Items Common to Scope Mode and Recorder Mode

- Turning waveform input on or off
- Display label
- Sensor
- Executes strain balancing
- Filter (bandwidth limit, digital filter)
- Display setup (display group)
- Display range settings
- Range unit
- Inverted waveform display
- Sample rate and sample interval settings
- Linear scaling
- Measurement range

► “Strain Measurement” in the Features Guide

Channel Setup Menu

1. On the waveform screen’s **MENU**, tap **VERTICAL** > **CH**, or press **CH**. A channel setup menu appears.
(You can also tap the channel information display area at the top of the screen to display the channel setup menu.)
2. Tap a channel you want to configure, or select it using the jog dial or up and down arrow keys.

Channel setup menu (1/2)

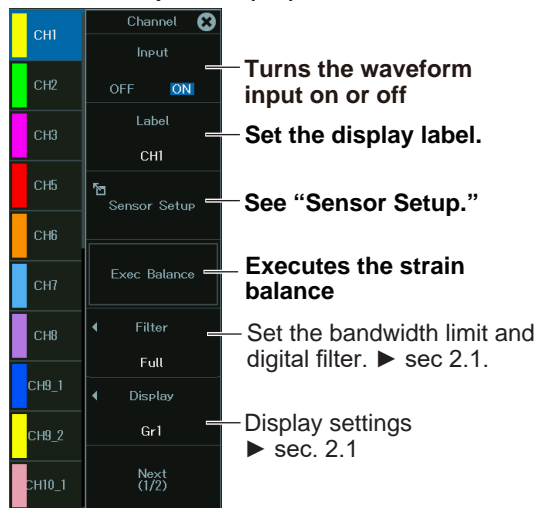

Channel setup menu (2/2)

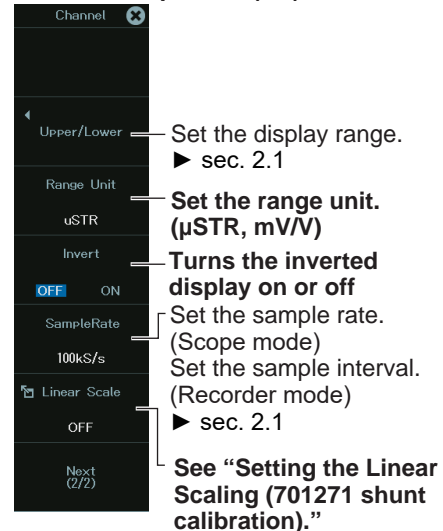

Sensor Setup (Sensor Setup)

3. Tap **Sensor Setup**, or press the soft key. The following screen appears.

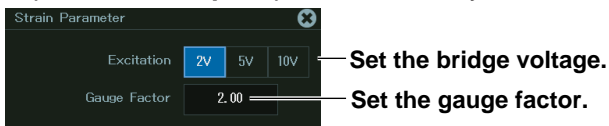

Setting the Range Unit (Range Unit)

μSTR: Units of strain ($\times 10^{-6}$ strain)

mV/V: Units of strain-gauge-transducer output

The mV/V range is calculated from the following equation.

$$\text{mV/V} = 0.5 \times (\mu\text{STR}/1000)$$

Setting the Linear Scaling (Linear Scale) (shunt calibration)

3. Tap **Linear Scale**, or press the soft key.

For the 701270 strain module, see “Linear Scaling” in section 2.1.

For the 701271 strain module, the following screen appears.

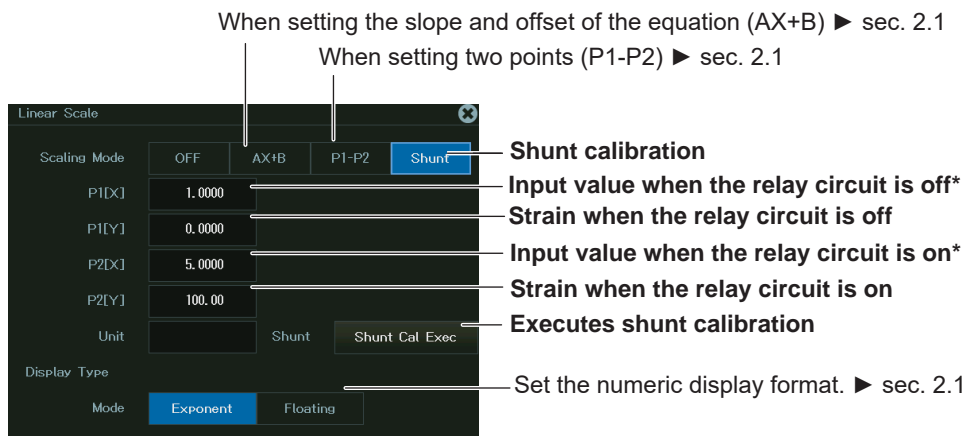

* When shunt calibration is executed, the values are entered.

Setting the Measurement Range (SCALE knob)

3. After selecting a channel, turn the SCALE knob to set the measurement range.

If you turn the SCALE knob while the acquisition is stopped, the new measurement range is applied the next time you start waveform acquisition.

Setting the Waveform Vertical and Horizontal Positions (Sliding the waveform screen)

- section 2.1

2.6 Configuring Acceleration Measurements

This section explains the following settings for acceleration measurements:

Scope Mode

- Turning waveform input on and off
- Display label
- Input coupling
- Turning the bias current supply to the acceleration sensor on and off
- Filter (bandwidth limit, digital filter)
- Display setup (display group)
- Zoom method (DIV/SPAN) switching
- Vertical zoom (vertical zoom, offset), upper and lower display range limits
- Gain
- Acceleration sensor sensitivity
- Sample rate
- Acceleration unit
- Vertical position

Recorder Mode

- Turning waveform input on and off
- Display label
- Input coupling
- Turning the bias current supply to the acceleration sensor on and off
- Filter (bandwidth limit, digital filter)
- Display setup (display group)
- Upper and lower limits of the display range
- Gain
- Acceleration sensor sensitivity
- Sample interval
- Acceleration unit
- Vertical position

► [“Acceleration Measurement” in the Features Guide](#)

Channel Setup Menu

1. On the waveform screen's **MENU**, tap **VERTICAL > CH**, or press **CH**. A channel setup menu appears.
(You can also tap the channel information display area at the top of the screen to display the channel setup menu.)
2. Tap a channel you want to configure, or select it using the jog dial or up and down arrow keys.

Scope Mode

Channel setup menu (1/2)

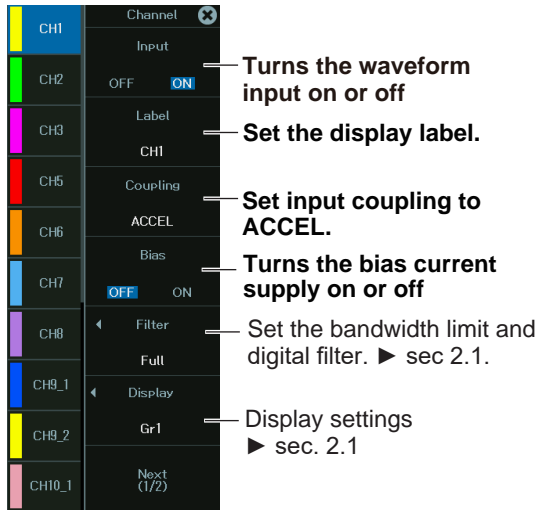

Channel setup menu (2/2)

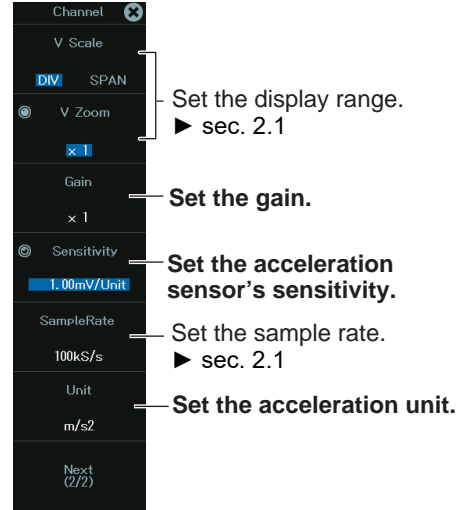

Recorder Mode

Channel setup menu (1/2)

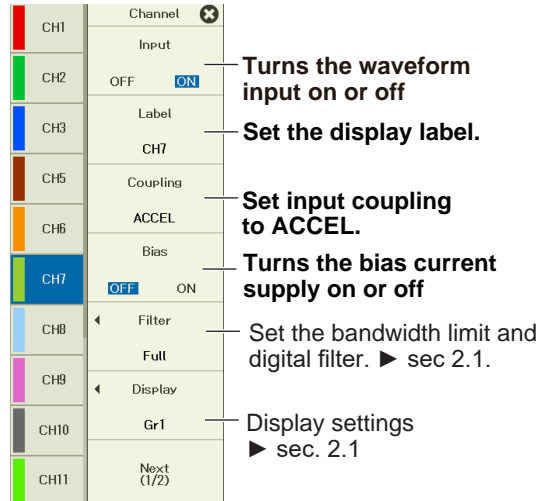

Channel setup menu (2/2)

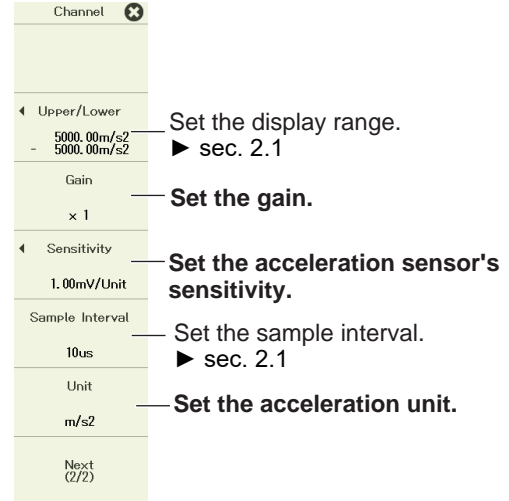

Setting the Input Coupling (Coupling)

To measure acceleration, set the input coupling to ACCEL.

To measure voltage, set the input coupling to an appropriate voltage measurement setting. ►
section 2.1

Setting the Waveform Vertical and Horizontal Positions (Sliding the waveform screen)

► section 2.1

2.7 Configuring Frequency, Revolution, Period, Duty Cycle, Power Supply Frequency, Pulse Width, Pulse Integration, and Velocity Measurements

This section explains the following settings for frequency, revolution, period, duty cycle, power supply frequency, pulse width, pulse integration, and velocity measurements:

Scope Mode

- Turning waveform input or and off
- Display label
- FV setup (measurement items)
- Input condition
- Filter (bandwidth limit, digital filter)
- Display setup (display group)
- Zoom method (DIV/SPAN) switching
- Vertical zoom (vertical zoom, offset), upper and lower display range limits
- Sample rate
- Linear scaling
- Vertical scale
- Vertical position

Recorder Mode

- Turning waveform input or and off
- Display label
- FV setup (measurement items)
- Input condition
- Filter (bandwidth limit, digital filter)
- Display setup (display group)
- Upper and lower limits of the display range
- Sample interval
- Linear scaling
- Vertical scale
- Vertical position

► [“Frequency Measurement” in the Features Guide](#)

Channel Setup Menu

- On the waveform screen's **MENU**, tap **VERTICAL** > **CH**, or press **CH**. A channel setup menu appears.
(You can also tap the channel information display area at the top of the screen to display the channel setup menu.)
- Tap a channel you want to configure, or select it using the jog dial or up and down arrow keys.

Scope Mode

Channel setup menu (1/2)

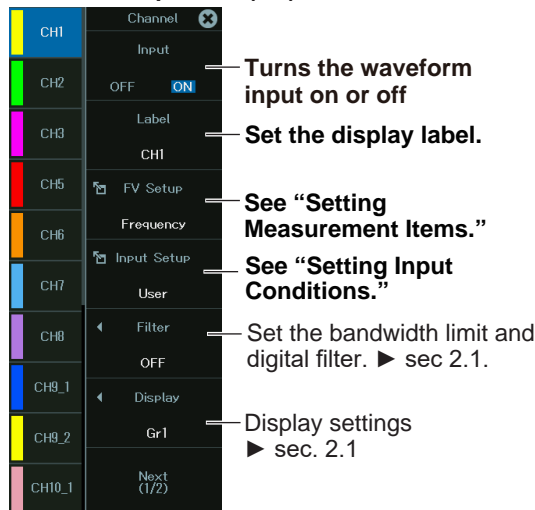

Channel setup menu (2/2)

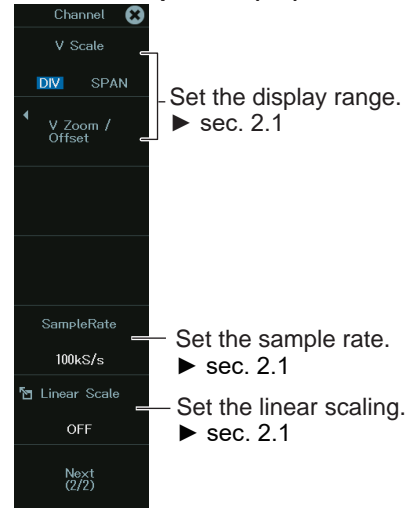

Recorder Mode

Channel setup menu (1/2)

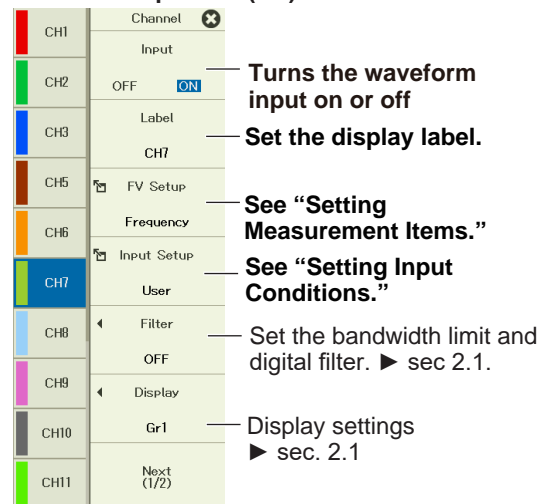

Channel setup menu (2/2)

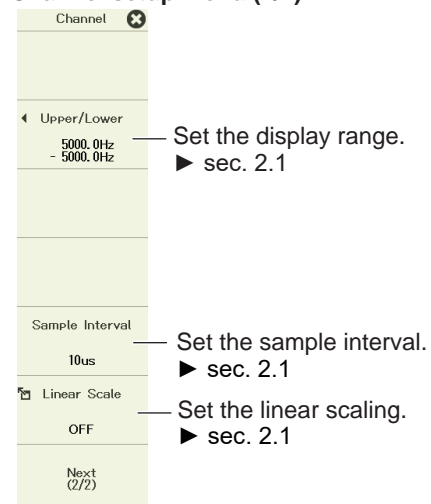

Setting Measurement Items (FV Setup)

3. Tap **FV Setup**, or press the soft key. The following screen appears.

When Performing Frequency or Period Measurements

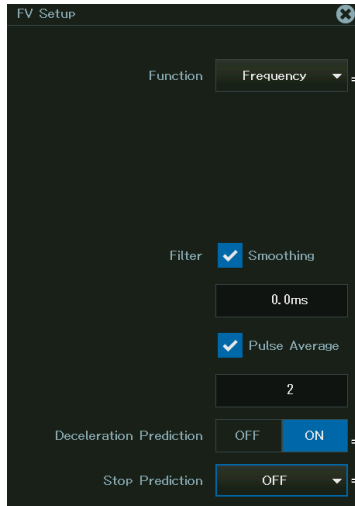

The screenshot shows the 'FV Setup' screen with the following settings:

- Function: Frequency
- Filter: Smoothing, 0.0ms
- Pulse Average, 2
- Deceleration Prediction: OFF ON
- Stop Prediction: OFF

Annotations:

- Set Function to Frequency or Period.
- Set the filter (Smoothing, PulseAverage).
- Turns decelerating prediction on or off
- Set the stop prediction (OFF, 1.5, 2, 3, 4, 5, 6, 7, 8, 9, 10).

When Performing Revolution Measurements

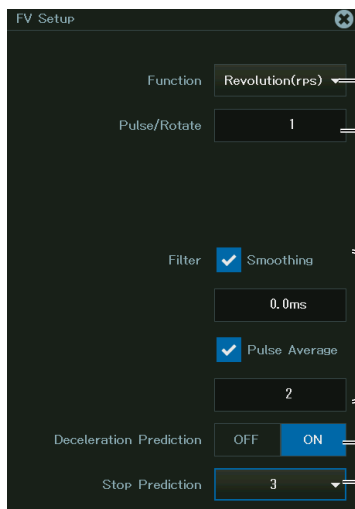

The screenshot shows the 'FV Setup' screen with the following settings:

- Function: Revolution(rps)
- Pulse/Rotate: 1
- Filter: Smoothing, 0.0ms
- Pulse Average, 2
- Deceleration Prediction: OFF ON
- Stop Prediction: 3

Annotations:

- Set Function to Revolution(rpm) or Revolution(rps).
- Set the pulse and rotate values.
- Set the filter (Smoothing, PulseAverage).
- Turns decelerating prediction on or off
- Set the stop prediction (OFF, 1.5, 2, 3, 4, 5, 6, 7, 8, 9, 10).

When Performing Duty Cycle or Pulse Width Measurements

The screenshot shows the 'FV Setup' dialog with the following settings:

- Function:** Duty (dropdown menu)
- Measure Pulse:** Positive (dropdown menu)
- Filter:** Smoothing (checked checkbox)
- Filter Value:** 0.0ms (text input)
- Time Out:** 10.00100s (text input)

 Annotations on the right side:

- Line to 'Duty': **Select Duty or Pulse Width.**
- Line to 'Positive': **Set the pulse to measure (Positive, Negative).**
- Line to 'Smoothing' and '0.0ms': **Set the filter (Smoothing).**
- Line to '10.00100s': **Set Time Out. (For the 720281)**

When Performing Power Supply Frequency Measurements

The screenshot shows the 'FV Setup' dialog with the following settings:

- Function:** Power Freq (dropdown menu)
- Center Freq:** 50Hz (dropdown menu)
- Filter:** Smoothing (checked checkbox)
- Filter Value:** 0.0ms (text input)
- Filter:** Pulse Average (checked checkbox)
- Filter Value:** 2 (text input)

 Annotations on the right side:

- Line to 'Power Freq': **Set Function to Power Freq.**
- Line to '50Hz': **Set the center frequency (50Hz, 60Hz, 400Hz).**
- Line to 'Smoothing' and 'Pulse Average': **Set the filter (Smoothing, PulseAverage).**

When Performing Pulse Integration Measurements

The screenshot shows the 'FV Setup' dialog with the following settings:

- Function:** Pulse Integ (dropdown menu)
- Unit/Pulse:** 1.0000 (text input)
- Unit:** (empty text input)
- Filter:** Smoothing (checked checkbox)
- Filter Value:** 0.0ms (text input)
- Filter:** Pulse Average (checked checkbox)
- Filter Value:** 2 (text input)
- Over Limit Reset:** OFF (radio button selected)
- Reset:** Execute (button)

 Annotations on the right side:

- Line to 'Pulse Integ': **Select Pulse Integ.**
- Line to '1.0000': **Set the unit and pulse.**
- Line to 'Unit': **Set the unit.**
- Line to 'Smoothing' and 'Pulse Average': **Set the filter (Smoothing, PulseAverage).**
- Line to 'OFF': **Turns over-limit reset on or off**
- Line to 'Execute': **Executes the manual reset of the pulse count**

When Performing Velocity Measurements

The screenshot shows the 'FV Setup' screen with the following settings and annotations:

- Function:** Velocity (dropdown menu) — Select Velocity.
- Distance/Pulse:** 1.0000 (text input) — Set the distance and pulse.
- Time Unit:** Second (dropdown menu) — Set the time unit (Hour, Minute, Second).
- Unit:** m/s (dropdown menu) — Set the unit.
- Filter:** Smoothing (checkbox checked) and Pulse Average (checkbox checked) — Set the filter (Smoothing, PulseAverage).
- Filter Value:** 0.0ms (text input) — Set the filter (Smoothing, PulseAverage).
- Deceleration Prediction:** ON (radio button selected) — Turns decelerating prediction on or off.
- Stop Prediction:** OFF (dropdown menu) — Set the stop prediction (OFF, 1.5, 2, 3, 4, 5, 6, 7, 8, 9, 10).

Setting Input Conditions (Input Setup)

3. Tap **Input Setup**, or press the soft key. The following screen appears.

The screenshot shows the 'Input Setup' screen with the following settings and annotations:

- Preset:** User (dropdown menu) — Set the preset.
- V Range:** ±10V (dropdown menu) — Set the voltage range.
- Coupling:** DC (dropdown menu) — Set the input coupling.
- Probe:** 1:1 (dropdown menu) — Set the probe type.
- Bandwidth:** Full (dropdown menu) — Set the bandwidth limits.
- Threshold:** 0.0V (text input) — Set the threshold level.
- Hysteresis:** $\overline{\overline{\wedge}}$ (radio button selected) — Set the hysteresis ($\overline{\wedge}$, $\overline{\overline{\wedge}}$, $\overline{\overline{\overline{\wedge}}}$).
- Slope:** $\overline{\wedge}$ (radio button selected) — Set the slope ($\overline{\wedge}$, $\overline{\nabla}$).
- Chatter Elimination:** 0ms (text input) — Set the chatter elimination.

When Preset is set to Pull-up 5V

Pull Up: OFF (radio button selected) — Turns pull-up on or off

Setting the Preset

You can set the preset to one of the following 10 options: Logic 5V, Logic 3V, Logic 12V, Logic 24V, Pull-up 5V, ZeroCross, AC100V, AC200V, EM Pickup, or User (user-defined).

The settable input items differ depending on the preset that you set. You can only turn pull-up on and off when the preset is set to Pull-up 5V.

Setting the Vertical Scale (SCALE knob)

▶ section 2.1

Setting the Waveform Vertical and Horizontal Positions (Sliding the waveform screen)

▶ section 2.1

2.8 Configuring Logic Signal Measurements

This section explains the following settings for logic measurements:

Items Common to Scope Mode and Recorder Mode

- Turning waveform input on or off
- Display label
- Logic settings
- Deskewing
- Sample Rate and Sample Interval
- Set the zoom percentage
- Display setup (display group)
- Vertical position

► [“Logic Measurement” in the Features Guide](#)

Channel Setup Menu

1. On the waveform screen’s **MENU**, tap **VERTICAL** > **CH**, or press **CH**. A channel setup menu appears.

(You can also tap the channel information display area at the top of the screen to display the channel setup menu.)

2. Tap a channel you want to configure, or select it using the jog dial or up and down arrow keys.

The screenshot shows the Channel Setup Menu for CH6. The menu items and their corresponding annotations are:

Channel	Setting	Annotation
CH1	Channel	
CH2	Input	
CH2	OFF ON	Turns the waveform input on or off
CH3	Label	Set the display label.
CH3	CH6	
CH5	Bit Setup	See “Setting Logic Bits.”
CH6	Skew Adjustment	Deskewing
CH7	0.0us	
CH8	SampleRate	Set the sample rate (Scope mode). Set the sample interval (Recorder mode). ► sec. 2.1
CH8	100kS/s	
CH9	V Zoom	
CH10	x 1	Set the display range. ► sec. 2.1
CH10	Display	
CH11	Gr1	Display settings ► sec. 2.1

Setting Logic Bits (Logic Setup)

3. Tap **Logic Setup**, or press the soft key. The following screen appears.

Use the check boxes to turn the display on or off for each bit and press the buttons to set the label for each bit.

Set the chatter elimination.

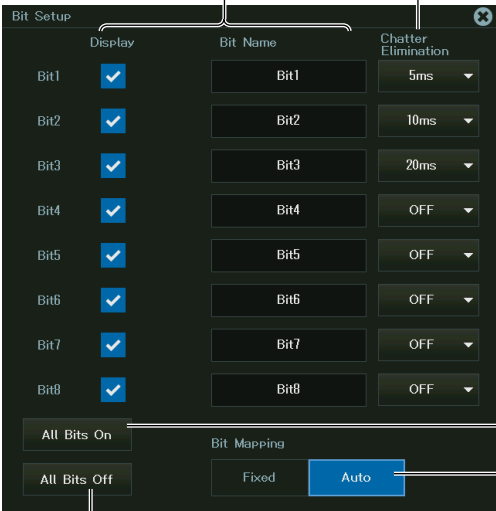

Turns the display on for all bits

Turns the display on or off for all bits

Bit mapping

Fixed (Fixed): The display position is fixed regardless of the bit settings.

Auto (Auto): The display position is set automatically according to the bit settings.

Bit	Display	Bit Name	Chatter Elimination
Bit1	<input checked="" type="checkbox"/>	Bit1	5ms
Bit2	<input checked="" type="checkbox"/>	Bit2	10ms
Bit3	<input checked="" type="checkbox"/>	Bit3	20ms
Bit4	<input checked="" type="checkbox"/>	Bit4	OFF
Bit5	<input checked="" type="checkbox"/>	Bit5	OFF
Bit6	<input checked="" type="checkbox"/>	Bit6	OFF
Bit7	<input checked="" type="checkbox"/>	Bit7	OFF
Bit8	<input checked="" type="checkbox"/>	Bit8	OFF

Setting the Vertical Scale (SCALE knob)

- section 2.1

Setting the Waveform Vertical and Horizontal Positions (Sliding the waveform screen)

- section 2.1

2.9 Configuring the Monitoring of CAN and CAN FD Bus Signals (/VCE option)

This section explains the following settings for monitoring CAN and CAN FD bus signals.

Items Common to Scope Mode and Recorder Mode

- Turning waveform input on or off
- Data frame reading settings (all sub channel settings, factor and offset settings of all sub channels, port settings, definition file loading)
- Individual sub channel scales
- Display group
- Setting and executing one-shot output
- Scaling of all sub channels
- Sample rate and sample interval settings

► [“CAN and CAN FD Bus Signal Monitoring \(/VCE option\)” in the Features Guide](#)

Channel Setup Menu

1. On the waveform screen’s **MENU**, tap **VERTICAL > CH**, or press **CH**. A channel setup menu appears.
(You can also tap the channel information display area at the top of the screen to display the channel setup menu.)
2. Tap a channel you want to configure, or select it using the jog dial or up and down arrow keys.

Channel setup menu (1/2)

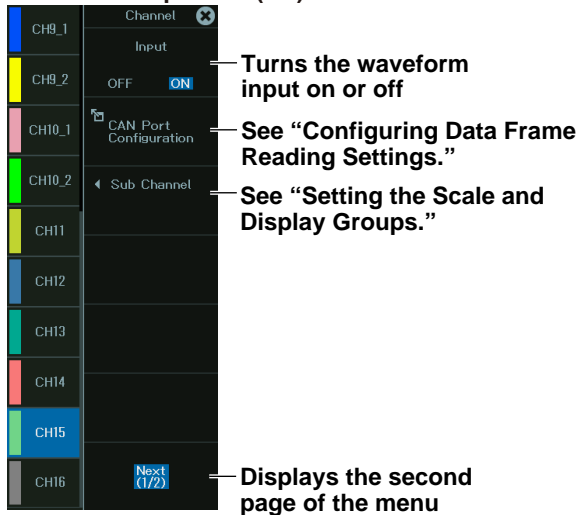

Channel setup menu (2/2)

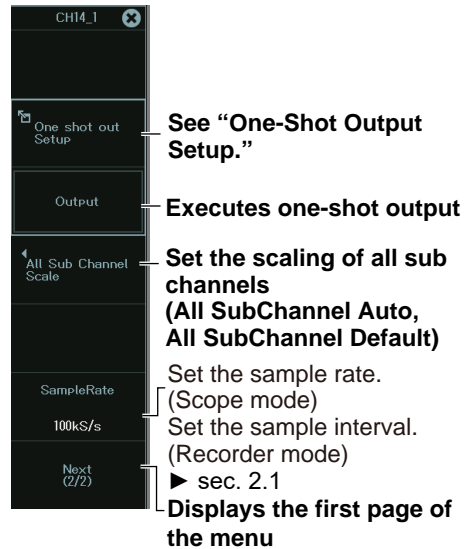

Configuring Data Frame Reading Settings (CAN Port Configuration)

3. Tap **CAN Port Configuration**, or press the soft key.

All Sub Channel Setup (All SubChannel Setup - CAN or CAN FD Data Extraction Conditions)

4. Tap **All SubChannel Setup**, or press the soft key. The following screen appears.

Turns sub channels on or off
Set each sub channel's input to on or off.

Turns all sub channel on or off

CAN or CAN FD data extraction conditions

	Input	Label	Msg Fmt	ID(Hex)	Byte Count	Start Bit	Bit Cnt	Byte Order	Value Type
All	<input type="radio"/> OFF								
1	<input checked="" type="checkbox"/> ON	CH14_1	STD	0x000	Auto	0	8	Big	Logic
2	<input checked="" type="checkbox"/> ON	CH14_2	STD	0x000	Auto	0	8	Big	Logic
3	<input checked="" type="checkbox"/> ON	CH14_3	STD	0x000	Auto	0	8	Big	Unsign
4	<input checked="" type="checkbox"/> ON	CH14_4	STD	0x000	Auto	0	8	Big	Unsign
5	<input checked="" type="checkbox"/> ON	CH14_5	STD	0x000	Auto	0	8	Big	Unsign
6	<input type="radio"/> OFF	CH14_6	STD	0x000	Auto	0	8	Big	Unsign
7	<input type="radio"/> OFF	CH14_7	STD	0x000	Auto	0	8	Big	Unsign
8	<input type="radio"/> OFF	CH14_8	STD	0x000	Auto	0	8	Big	Unsign
9	<input type="radio"/> OFF	CH14_9	STD	0x000	Auto	0	8	Big	Unsign
10	<input type="radio"/> OFF	CH14_10	STD	0x000	Auto	0	8	Big	Unsign

Configuration

- All Sub Channel Set...
- All SubChannel Factor/Offset
- Port Setup
- Symbol File Load

See "Setting All Sub Channel Factor/Offset."

See "Port Setup."

See "Loading Definition Files."

5. Tap each item. Use the displayed list (options) or input box to set the items.

Setting All Sub Channel Factor/Offset (All SubChannel Factor/Offset - CAN or CAN FD Data Conversion Condition)

4. Tap All SubChannel Factor/Offset, or press the soft key. The following screen appears.

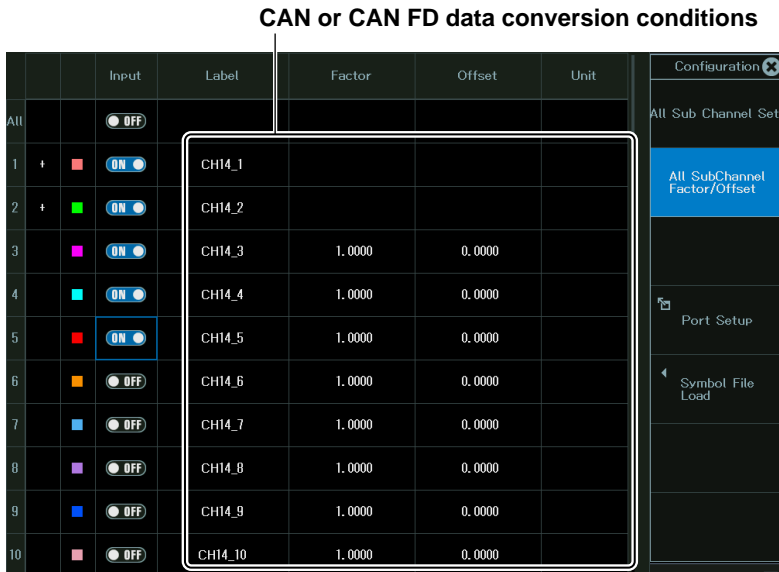

5. Tap each item. Use the displayed input box to set the items.

Port Setup (Port Setup)

4. Tap Port Setup, or press the soft key. The following screen appears.

CAN Bus Signal Monitoring (for the 720240 (CAN MONITOR), 720241 (CAN & LIN) modules)

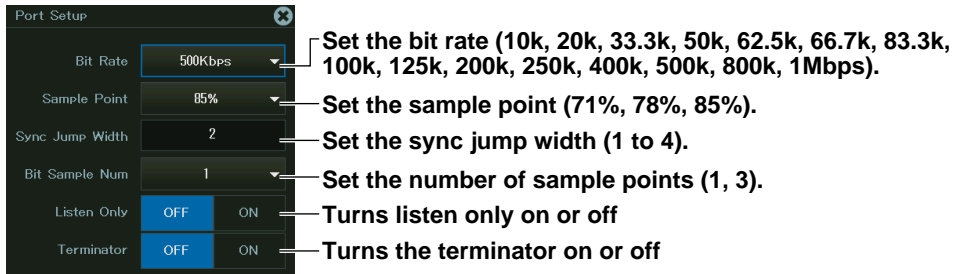

CAN and CAN FD Bus Signal Monitoring (for the 720242 (CAN/CAN FD) module)

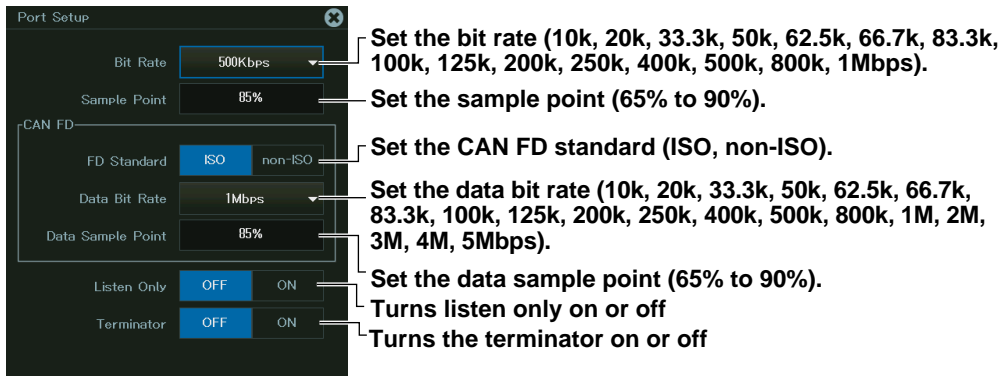

Loading Definition Files (Symbol File Load)

4. Tap **Symbol File Load**, or press the soft key. A file list appears.
5. On the file list, tap a symbol file (SBL file).
For details on file list operations, see section 19.10.
6. Tap **Load**. A confirmation message appears.
7. Tap **OK**. The symbol file is loaded.

Setting the Scale and Display Groups (Sub Channel)

3. Tap **Sub Channel**, or press the soft key.

When the Data Type (Value Type) Is Unsigned, Signed, or Float

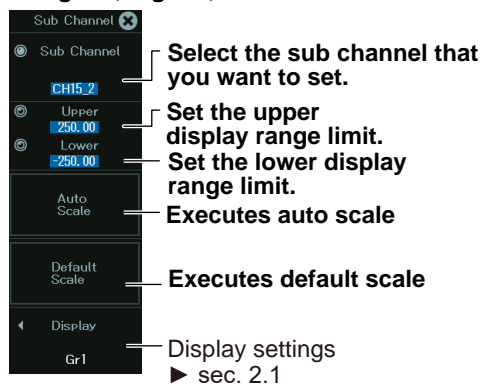

When the Data Type (Value Type) is Logic

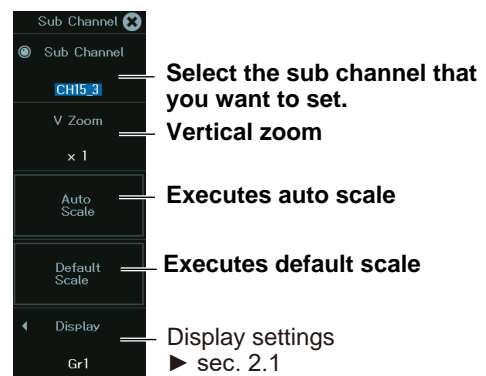

One-Shot Output Setup (One shot out Setup)

3. Tap **One Shot Out Setup**, or press the soft key. The following screen appears.

CAN Frame One-Shot Output (for the 720240 (CAN MONITOR), 720241 (CAN & LIN) modules)

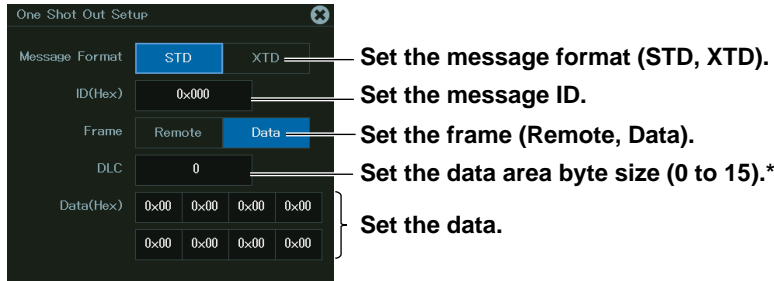

Set the message format (STD, XTD).
Set the message ID.
Set the frame (Remote, Data).
Set the data area byte size (0 to 15).*
Set the data.

* Can only be set when Frame is set to Data.

CAN or CAN FD Frame One-Shot Output (for the 720242 (CAN/CAN FD) module)

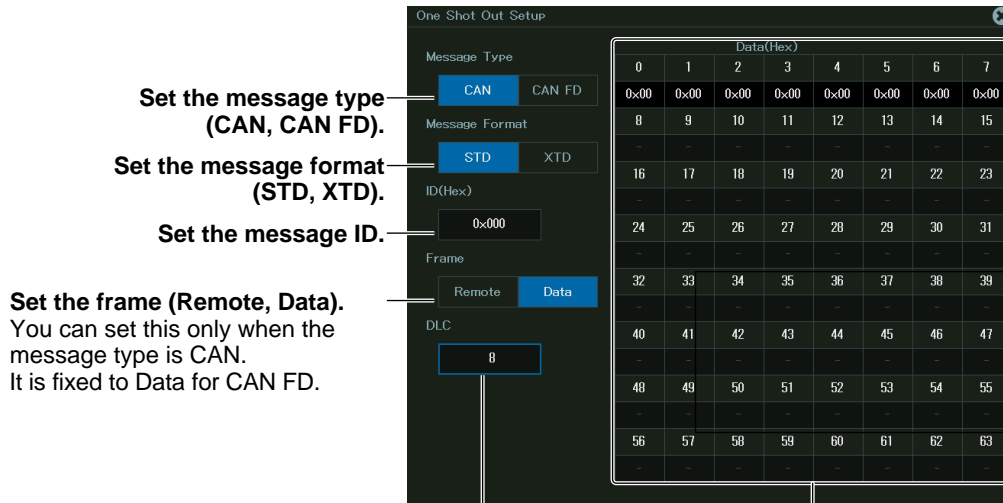

Set the message type (CAN, CAN FD).
Set the message format (STD, XTD).
Set the message ID.

Set the frame (Remote, Data).
You can set this only when the message type is CAN.
It is fixed to Data for CAN FD.

Set the data area byte size (0 to 15).*

Data*
The number of transmission data bytes that can be set varies depending on the message type and DLC settings.

► Next page

* Can only be set when Frame is set to Data.

DLC Value and the Number of Transmission Data Bytes

When DLC = 0 to 8

DLC	Number of Data Bytes		DLC	Number of Data Bytes		DLC	Number of Data Bytes																																																	
	CAN	CAN FD		CAN	CAN FD		CAN	CAN FD																																																
0	0	0	1	1	1	2	2	2																																																
<table border="1"> <tr><td>0</td><td>1</td><td>2</td><td>3</td><td>4</td><td>5</td><td>6</td><td>7</td></tr> <tr><td>-</td><td>-</td><td>-</td><td>-</td><td>-</td><td>-</td><td>-</td><td>-</td></tr> </table>			0	1	2	3	4	5	6	7	-	-	-	-	-	-	-	-	<table border="1"> <tr><td>0</td><td>1</td><td>2</td><td>3</td><td>4</td><td>5</td><td>6</td><td>7</td></tr> <tr><td>0x00</td><td>-</td><td>-</td><td>-</td><td>-</td><td>-</td><td>-</td><td>-</td></tr> </table>			0	1	2	3	4	5	6	7	0x00	-	-	-	-	-	-	-	<table border="1"> <tr><td>0</td><td>1</td><td>2</td><td>3</td><td>4</td><td>5</td><td>6</td><td>7</td></tr> <tr><td>0x00</td><td>0x00</td><td>-</td><td>-</td><td>-</td><td>-</td><td>-</td><td>-</td></tr> </table>			0	1	2	3	4	5	6	7	0x00	0x00	-	-	-	-	-	-
0	1	2	3	4	5	6	7																																																	
-	-	-	-	-	-	-	-																																																	
0	1	2	3	4	5	6	7																																																	
0x00	-	-	-	-	-	-	-																																																	
0	1	2	3	4	5	6	7																																																	
0x00	0x00	-	-	-	-	-	-																																																	
3	3	3	4	4	4	5	5	5																																																
<table border="1"> <tr><td>0</td><td>1</td><td>2</td><td>3</td><td>4</td><td>5</td><td>6</td><td>7</td></tr> <tr><td>0x00</td><td>0x00</td><td>0x00</td><td>-</td><td>-</td><td>-</td><td>-</td><td>-</td></tr> </table>			0	1	2	3	4	5	6	7	0x00	0x00	0x00	-	-	-	-	-	<table border="1"> <tr><td>0</td><td>1</td><td>2</td><td>3</td><td>4</td><td>5</td><td>6</td><td>7</td></tr> <tr><td>0x00</td><td>0x00</td><td>0x00</td><td>0x00</td><td>-</td><td>-</td><td>-</td><td>-</td></tr> </table>			0	1	2	3	4	5	6	7	0x00	0x00	0x00	0x00	-	-	-	-	<table border="1"> <tr><td>0</td><td>1</td><td>2</td><td>3</td><td>4</td><td>5</td><td>6</td><td>7</td></tr> <tr><td>0x00</td><td>0x00</td><td>0x00</td><td>0x00</td><td>0x00</td><td>-</td><td>-</td><td>-</td></tr> </table>			0	1	2	3	4	5	6	7	0x00	0x00	0x00	0x00	0x00	-	-	-
0	1	2	3	4	5	6	7																																																	
0x00	0x00	0x00	-	-	-	-	-																																																	
0	1	2	3	4	5	6	7																																																	
0x00	0x00	0x00	0x00	-	-	-	-																																																	
0	1	2	3	4	5	6	7																																																	
0x00	0x00	0x00	0x00	0x00	-	-	-																																																	
6	6	6	7	7	7	8	8	8																																																
<table border="1"> <tr><td>0</td><td>1</td><td>2</td><td>3</td><td>4</td><td>5</td><td>6</td><td>7</td></tr> <tr><td>0x00</td><td>0x00</td><td>0x00</td><td>0x00</td><td>0x00</td><td>0x00</td><td>-</td><td>-</td></tr> </table>			0	1	2	3	4	5	6	7	0x00	0x00	0x00	0x00	0x00	0x00	-	-	<table border="1"> <tr><td>0</td><td>1</td><td>2</td><td>3</td><td>4</td><td>5</td><td>6</td><td>7</td></tr> <tr><td>0x00</td><td>0x00</td><td>0x00</td><td>0x00</td><td>0x00</td><td>0x00</td><td>0x00</td><td>-</td></tr> </table>			0	1	2	3	4	5	6	7	0x00	0x00	0x00	0x00	0x00	0x00	0x00	-	<table border="1"> <tr><td>0</td><td>1</td><td>2</td><td>3</td><td>4</td><td>5</td><td>6</td><td>7</td></tr> <tr><td>0x00</td><td>0x00</td><td>0x00</td><td>0x00</td><td>0x00</td><td>0x00</td><td>0x00</td><td>0x00</td></tr> </table>			0	1	2	3	4	5	6	7	0x00	0x00	0x00	0x00	0x00	0x00	0x00	0x00
0	1	2	3	4	5	6	7																																																	
0x00	0x00	0x00	0x00	0x00	0x00	-	-																																																	
0	1	2	3	4	5	6	7																																																	
0x00	0x00	0x00	0x00	0x00	0x00	0x00	-																																																	
0	1	2	3	4	5	6	7																																																	
0x00	0x00	0x00	0x00	0x00	0x00	0x00	0x00																																																	

When DLC ≥ 9

When the message type is CAN

DLC	Number of Data Bytes
9 to 15	8

When the message type is CAN FD

DLC	Number of Data Bytes	DLC	Number of Data Bytes	DLC	Number of Data Bytes																																																																																																																																																																																																																																																																																																
9	12	10	16	11	20																																																																																																																																																																																																																																																																																																
<table border="1"> <tr><td>0</td><td>1</td><td>2</td><td>3</td><td>4</td><td>5</td><td>6</td><td>7</td></tr> <tr><td>0x00</td><td>0x00</td><td>0x00</td><td>0x00</td><td>0x00</td><td>0x00</td><td>0x00</td><td>0x00</td></tr> <tr><td>8</td><td>9</td><td>10</td><td>11</td><td>12</td><td>13</td><td>14</td><td>15</td></tr> <tr><td>0x00</td><td>0x00</td><td>0x00</td><td>0x00</td><td>-</td><td>-</td><td>-</td><td>-</td></tr> <tr><td>16</td><td>17</td><td>18</td><td>19</td><td>20</td><td>21</td><td>22</td><td>23</td></tr> <tr><td>-</td><td>-</td><td>-</td><td>-</td><td>-</td><td>-</td><td>-</td><td>-</td></tr> </table>		0	1	2	3	4	5	6	7	0x00	0x00	0x00	0x00	0x00	0x00	0x00	0x00	8	9	10	11	12	13	14	15	0x00	0x00	0x00	0x00	-	-	-	-	16	17	18	19	20	21	22	23	-	-	-	-	-	-	-	-	<table border="1"> <tr><td>0</td><td>1</td><td>2</td><td>3</td><td>4</td><td>5</td><td>6</td><td>7</td></tr> <tr><td>0x00</td><td>0x00</td><td>0x00</td><td>0x00</td><td>0x00</td><td>0x00</td><td>0x00</td><td>0x00</td></tr> <tr><td>8</td><td>9</td><td>10</td><td>11</td><td>12</td><td>13</td><td>14</td><td>15</td></tr> <tr><td>0x00</td><td>0x00</td><td>0x00</td><td>0x00</td><td>0x00</td><td>0x00</td><td>0x00</td><td>0x00</td></tr> <tr><td>16</td><td>17</td><td>18</td><td>19</td><td>20</td><td>21</td><td>22</td><td>23</td></tr> <tr><td>-</td><td>-</td><td>-</td><td>-</td><td>-</td><td>-</td><td>-</td><td>-</td></tr> </table>		0	1	2	3	4	5	6	7	0x00	0x00	0x00	0x00	0x00	0x00	0x00	0x00	8	9	10	11	12	13	14	15	0x00	0x00	0x00	0x00	0x00	0x00	0x00	0x00	16	17	18	19	20	21	22	23	-	-	-	-	-	-	-	-	<table border="1"> <tr><td>0</td><td>1</td><td>2</td><td>3</td><td>4</td><td>5</td><td>6</td><td>7</td></tr> <tr><td>0x00</td><td>0x00</td><td>0x00</td><td>0x00</td><td>0x00</td><td>0x00</td><td>0x00</td><td>0x00</td></tr> <tr><td>8</td><td>9</td><td>10</td><td>11</td><td>12</td><td>13</td><td>14</td><td>15</td></tr> <tr><td>0x00</td><td>0x00</td><td>0x00</td><td>0x00</td><td>0x00</td><td>0x00</td><td>0x00</td><td>0x00</td></tr> <tr><td>16</td><td>17</td><td>18</td><td>19</td><td>20</td><td>21</td><td>22</td><td>23</td></tr> <tr><td>0x00</td><td>0x00</td><td>0x00</td><td>0x00</td><td>-</td><td>-</td><td>-</td><td>-</td></tr> </table>		0	1	2	3	4	5	6	7	0x00	0x00	0x00	0x00	0x00	0x00	0x00	0x00	8	9	10	11	12	13	14	15	0x00	0x00	0x00	0x00	0x00	0x00	0x00	0x00	16	17	18	19	20	21	22	23	0x00	0x00	0x00	0x00	-	-	-	-																																																																																																																																																
0	1	2	3	4	5	6	7																																																																																																																																																																																																																																																																																														
0x00	0x00	0x00	0x00	0x00	0x00	0x00	0x00																																																																																																																																																																																																																																																																																														
8	9	10	11	12	13	14	15																																																																																																																																																																																																																																																																																														
0x00	0x00	0x00	0x00	-	-	-	-																																																																																																																																																																																																																																																																																														
16	17	18	19	20	21	22	23																																																																																																																																																																																																																																																																																														
-	-	-	-	-	-	-	-																																																																																																																																																																																																																																																																																														
0	1	2	3	4	5	6	7																																																																																																																																																																																																																																																																																														
0x00	0x00	0x00	0x00	0x00	0x00	0x00	0x00																																																																																																																																																																																																																																																																																														
8	9	10	11	12	13	14	15																																																																																																																																																																																																																																																																																														
0x00	0x00	0x00	0x00	0x00	0x00	0x00	0x00																																																																																																																																																																																																																																																																																														
16	17	18	19	20	21	22	23																																																																																																																																																																																																																																																																																														
-	-	-	-	-	-	-	-																																																																																																																																																																																																																																																																																														
0	1	2	3	4	5	6	7																																																																																																																																																																																																																																																																																														
0x00	0x00	0x00	0x00	0x00	0x00	0x00	0x00																																																																																																																																																																																																																																																																																														
8	9	10	11	12	13	14	15																																																																																																																																																																																																																																																																																														
0x00	0x00	0x00	0x00	0x00	0x00	0x00	0x00																																																																																																																																																																																																																																																																																														
16	17	18	19	20	21	22	23																																																																																																																																																																																																																																																																																														
0x00	0x00	0x00	0x00	-	-	-	-																																																																																																																																																																																																																																																																																														
12	24	13	32	14	48																																																																																																																																																																																																																																																																																																
<table border="1"> <tr><td>0</td><td>1</td><td>2</td><td>3</td><td>4</td><td>5</td><td>6</td><td>7</td></tr> <tr><td>0x00</td><td>0x00</td><td>0x00</td><td>0x00</td><td>0x00</td><td>0x00</td><td>0x00</td><td>0x00</td></tr> <tr><td>8</td><td>9</td><td>10</td><td>11</td><td>12</td><td>13</td><td>14</td><td>15</td></tr> <tr><td>0x00</td><td>0x00</td><td>0x00</td><td>0x00</td><td>0x00</td><td>0x00</td><td>0x00</td><td>0x00</td></tr> <tr><td>16</td><td>17</td><td>18</td><td>19</td><td>20</td><td>21</td><td>22</td><td>23</td></tr> <tr><td>0x00</td><td>0x00</td><td>0x00</td><td>0x00</td><td>0x00</td><td>0x00</td><td>0x00</td><td>0x00</td></tr> <tr><td>24</td><td>25</td><td>26</td><td>27</td><td>28</td><td>29</td><td>30</td><td>31</td></tr> <tr><td>-</td><td>-</td><td>-</td><td>-</td><td>-</td><td>-</td><td>-</td><td>-</td></tr> <tr><td>32</td><td>33</td><td>34</td><td>35</td><td>36</td><td>37</td><td>38</td><td>39</td></tr> <tr><td>-</td><td>-</td><td>-</td><td>-</td><td>-</td><td>-</td><td>-</td><td>-</td></tr> <tr><td>40</td><td>41</td><td>42</td><td>43</td><td>44</td><td>45</td><td>46</td><td>47</td></tr> <tr><td>-</td><td>-</td><td>-</td><td>-</td><td>-</td><td>-</td><td>-</td><td>-</td></tr> </table>		0	1	2	3	4	5	6	7	0x00	0x00	0x00	0x00	0x00	0x00	0x00	0x00	8	9	10	11	12	13	14	15	0x00	0x00	0x00	0x00	0x00	0x00	0x00	0x00	16	17	18	19	20	21	22	23	0x00	0x00	0x00	0x00	0x00	0x00	0x00	0x00	24	25	26	27	28	29	30	31	-	-	-	-	-	-	-	-	32	33	34	35	36	37	38	39	-	-	-	-	-	-	-	-	40	41	42	43	44	45	46	47	-	-	-	-	-	-	-	-	<table border="1"> <tr><td>0</td><td>1</td><td>2</td><td>3</td><td>4</td><td>5</td><td>6</td><td>7</td></tr> <tr><td>0x00</td><td>0x00</td><td>0x00</td><td>0x00</td><td>0x00</td><td>0x00</td><td>0x00</td><td>0x00</td></tr> <tr><td>8</td><td>9</td><td>10</td><td>11</td><td>12</td><td>13</td><td>14</td><td>15</td></tr> <tr><td>0x00</td><td>0x00</td><td>0x00</td><td>0x00</td><td>0x00</td><td>0x00</td><td>0x00</td><td>0x00</td></tr> <tr><td>16</td><td>17</td><td>18</td><td>19</td><td>20</td><td>21</td><td>22</td><td>23</td></tr> <tr><td>0x00</td><td>0x00</td><td>0x00</td><td>0x00</td><td>0x00</td><td>0x00</td><td>0x00</td><td>0x00</td></tr> <tr><td>24</td><td>25</td><td>26</td><td>27</td><td>28</td><td>29</td><td>30</td><td>31</td></tr> <tr><td>0x00</td><td>0x00</td><td>0x00</td><td>0x00</td><td>0x00</td><td>0x00</td><td>0x00</td><td>0x00</td></tr> <tr><td>32</td><td>33</td><td>34</td><td>35</td><td>36</td><td>37</td><td>38</td><td>39</td></tr> <tr><td>-</td><td>-</td><td>-</td><td>-</td><td>-</td><td>-</td><td>-</td><td>-</td></tr> <tr><td>40</td><td>41</td><td>42</td><td>43</td><td>44</td><td>45</td><td>46</td><td>47</td></tr> <tr><td>-</td><td>-</td><td>-</td><td>-</td><td>-</td><td>-</td><td>-</td><td>-</td></tr> </table>		0	1	2	3	4	5	6	7	0x00	0x00	0x00	0x00	0x00	0x00	0x00	0x00	8	9	10	11	12	13	14	15	0x00	0x00	0x00	0x00	0x00	0x00	0x00	0x00	16	17	18	19	20	21	22	23	0x00	0x00	0x00	0x00	0x00	0x00	0x00	0x00	24	25	26	27	28	29	30	31	0x00	0x00	0x00	0x00	0x00	0x00	0x00	0x00	32	33	34	35	36	37	38	39	-	-	-	-	-	-	-	-	40	41	42	43	44	45	46	47	-	-	-	-	-	-	-	-	<table border="1"> <tr><td>0</td><td>1</td><td>2</td><td>3</td><td>4</td><td>5</td><td>6</td><td>7</td></tr> <tr><td>0x00</td><td>0x00</td><td>0x00</td><td>0x00</td><td>0x00</td><td>0x00</td><td>0x00</td><td>0x00</td></tr> <tr><td>8</td><td>9</td><td>10</td><td>11</td><td>12</td><td>13</td><td>14</td><td>15</td></tr> <tr><td>0x00</td><td>0x00</td><td>0x00</td><td>0x00</td><td>0x00</td><td>0x00</td><td>0x00</td><td>0x00</td></tr> <tr><td>16</td><td>17</td><td>18</td><td>19</td><td>20</td><td>21</td><td>22</td><td>23</td></tr> <tr><td>0x00</td><td>0x00</td><td>0x00</td><td>0x00</td><td>0x00</td><td>0x00</td><td>0x00</td><td>0x00</td></tr> <tr><td>24</td><td>25</td><td>26</td><td>27</td><td>28</td><td>29</td><td>30</td><td>31</td></tr> <tr><td>0x00</td><td>0x00</td><td>0x00</td><td>0x00</td><td>0x00</td><td>0x00</td><td>0x00</td><td>0x00</td></tr> <tr><td>32</td><td>33</td><td>34</td><td>35</td><td>36</td><td>37</td><td>38</td><td>39</td></tr> <tr><td>0x00</td><td>0x00</td><td>0x00</td><td>0x00</td><td>0x00</td><td>0x00</td><td>0x00</td><td>0x00</td></tr> <tr><td>40</td><td>41</td><td>42</td><td>43</td><td>44</td><td>45</td><td>46</td><td>47</td></tr> <tr><td>0x00</td><td>0x00</td><td>0x00</td><td>0x00</td><td>0x00</td><td>0x00</td><td>0x00</td><td>0x00</td></tr> </table>		0	1	2	3	4	5	6	7	0x00	0x00	0x00	0x00	0x00	0x00	0x00	0x00	8	9	10	11	12	13	14	15	0x00	0x00	0x00	0x00	0x00	0x00	0x00	0x00	16	17	18	19	20	21	22	23	0x00	0x00	0x00	0x00	0x00	0x00	0x00	0x00	24	25	26	27	28	29	30	31	0x00	0x00	0x00	0x00	0x00	0x00	0x00	0x00	32	33	34	35	36	37	38	39	0x00	0x00	0x00	0x00	0x00	0x00	0x00	0x00	40	41	42	43	44	45	46	47	0x00	0x00	0x00	0x00	0x00	0x00	0x00	0x00
0	1	2	3	4	5	6	7																																																																																																																																																																																																																																																																																														
0x00	0x00	0x00	0x00	0x00	0x00	0x00	0x00																																																																																																																																																																																																																																																																																														
8	9	10	11	12	13	14	15																																																																																																																																																																																																																																																																																														
0x00	0x00	0x00	0x00	0x00	0x00	0x00	0x00																																																																																																																																																																																																																																																																																														
16	17	18	19	20	21	22	23																																																																																																																																																																																																																																																																																														
0x00	0x00	0x00	0x00	0x00	0x00	0x00	0x00																																																																																																																																																																																																																																																																																														
24	25	26	27	28	29	30	31																																																																																																																																																																																																																																																																																														
-	-	-	-	-	-	-	-																																																																																																																																																																																																																																																																																														
32	33	34	35	36	37	38	39																																																																																																																																																																																																																																																																																														
-	-	-	-	-	-	-	-																																																																																																																																																																																																																																																																																														
40	41	42	43	44	45	46	47																																																																																																																																																																																																																																																																																														
-	-	-	-	-	-	-	-																																																																																																																																																																																																																																																																																														
0	1	2	3	4	5	6	7																																																																																																																																																																																																																																																																																														
0x00	0x00	0x00	0x00	0x00	0x00	0x00	0x00																																																																																																																																																																																																																																																																																														
8	9	10	11	12	13	14	15																																																																																																																																																																																																																																																																																														
0x00	0x00	0x00	0x00	0x00	0x00	0x00	0x00																																																																																																																																																																																																																																																																																														
16	17	18	19	20	21	22	23																																																																																																																																																																																																																																																																																														
0x00	0x00	0x00	0x00	0x00	0x00	0x00	0x00																																																																																																																																																																																																																																																																																														
24	25	26	27	28	29	30	31																																																																																																																																																																																																																																																																																														
0x00	0x00	0x00	0x00	0x00	0x00	0x00	0x00																																																																																																																																																																																																																																																																																														
32	33	34	35	36	37	38	39																																																																																																																																																																																																																																																																																														
-	-	-	-	-	-	-	-																																																																																																																																																																																																																																																																																														
40	41	42	43	44	45	46	47																																																																																																																																																																																																																																																																																														
-	-	-	-	-	-	-	-																																																																																																																																																																																																																																																																																														
0	1	2	3	4	5	6	7																																																																																																																																																																																																																																																																																														
0x00	0x00	0x00	0x00	0x00	0x00	0x00	0x00																																																																																																																																																																																																																																																																																														
8	9	10	11	12	13	14	15																																																																																																																																																																																																																																																																																														
0x00	0x00	0x00	0x00	0x00	0x00	0x00	0x00																																																																																																																																																																																																																																																																																														
16	17	18	19	20	21	22	23																																																																																																																																																																																																																																																																																														
0x00	0x00	0x00	0x00	0x00	0x00	0x00	0x00																																																																																																																																																																																																																																																																																														
24	25	26	27	28	29	30	31																																																																																																																																																																																																																																																																																														
0x00	0x00	0x00	0x00	0x00	0x00	0x00	0x00																																																																																																																																																																																																																																																																																														
32	33	34	35	36	37	38	39																																																																																																																																																																																																																																																																																														
0x00	0x00	0x00	0x00	0x00	0x00	0x00	0x00																																																																																																																																																																																																																																																																																														
40	41	42	43	44	45	46	47																																																																																																																																																																																																																																																																																														
0x00	0x00	0x00	0x00	0x00	0x00	0x00	0x00																																																																																																																																																																																																																																																																																														
15	64																																																																																																																																																																																																																																																																																																				
<table border="1"> <tr><td>0</td><td>1</td><td>2</td><td>3</td><td>4</td><td>5</td><td>6</td><td>7</td></tr> <tr><td>0x00</td><td>0x00</td><td>0x00</td><td>0x00</td><td>0x00</td><td>0x00</td><td>0x00</td><td>0x00</td></tr> <tr><td>8</td><td>9</td><td>10</td><td>11</td><td>12</td><td>13</td><td>14</td><td>15</td></tr> <tr><td>0x00</td><td>0x00</td><td>0x00</td><td>0x00</td><td>0x00</td><td>0x00</td><td>0x00</td><td>0x00</td></tr> <tr><td>16</td><td>17</td><td>18</td><td>19</td><td>20</td><td>21</td><td>22</td><td>23</td></tr> <tr><td>0x00</td><td>0x00</td><td>0x00</td><td>0x00</td><td>0x00</td><td>0x00</td><td>0x00</td><td>0x00</td></tr> <tr><td>24</td><td>25</td><td>26</td><td>27</td><td>28</td><td>29</td><td>30</td><td>31</td></tr> <tr><td>0x00</td><td>0x00</td><td>0x00</td><td>0x00</td><td>0x00</td><td>0x00</td><td>0x00</td><td>0x00</td></tr> <tr><td>32</td><td>33</td><td>34</td><td>35</td><td>36</td><td>37</td><td>38</td><td>39</td></tr> <tr><td>0x00</td><td>0x00</td><td>0x00</td><td>0x00</td><td>0x00</td><td>0x00</td><td>0x00</td><td>0x00</td></tr> <tr><td>40</td><td>41</td><td>42</td><td>43</td><td>44</td><td>45</td><td>46</td><td>47</td></tr> <tr><td>0x00</td><td>0x00</td><td>0x00</td><td>0x00</td><td>0x00</td><td>0x00</td><td>0x00</td><td>0x00</td></tr> <tr><td>48</td><td>49</td><td>50</td><td>51</td><td>52</td><td>53</td><td>54</td><td>55</td></tr> <tr><td>0x00</td><td>0x00</td><td>0x00</td><td>0x00</td><td>0x00</td><td>0x00</td><td>0x00</td><td>0x00</td></tr> <tr><td>56</td><td>57</td><td>58</td><td>59</td><td>60</td><td>61</td><td>62</td><td>63</td></tr> <tr><td>0x00</td><td>0x00</td><td>0x00</td><td>0x00</td><td>0x00</td><td>0x00</td><td>0x00</td><td>0x00</td></tr> </table>						0	1	2	3	4	5	6	7	0x00	0x00	0x00	0x00	0x00	0x00	0x00	0x00	8	9	10	11	12	13	14	15	0x00	0x00	0x00	0x00	0x00	0x00	0x00	0x00	16	17	18	19	20	21	22	23	0x00	0x00	0x00	0x00	0x00	0x00	0x00	0x00	24	25	26	27	28	29	30	31	0x00	0x00	0x00	0x00	0x00	0x00	0x00	0x00	32	33	34	35	36	37	38	39	0x00	0x00	0x00	0x00	0x00	0x00	0x00	0x00	40	41	42	43	44	45	46	47	0x00	0x00	0x00	0x00	0x00	0x00	0x00	0x00	48	49	50	51	52	53	54	55	0x00	0x00	0x00	0x00	0x00	0x00	0x00	0x00	56	57	58	59	60	61	62	63	0x00	0x00	0x00	0x00	0x00	0x00	0x00	0x00																																																																																																																																																																
0	1	2	3	4	5	6	7																																																																																																																																																																																																																																																																																														
0x00	0x00	0x00	0x00	0x00	0x00	0x00	0x00																																																																																																																																																																																																																																																																																														
8	9	10	11	12	13	14	15																																																																																																																																																																																																																																																																																														
0x00	0x00	0x00	0x00	0x00	0x00	0x00	0x00																																																																																																																																																																																																																																																																																														
16	17	18	19	20	21	22	23																																																																																																																																																																																																																																																																																														
0x00	0x00	0x00	0x00	0x00	0x00	0x00	0x00																																																																																																																																																																																																																																																																																														
24	25	26	27	28	29	30	31																																																																																																																																																																																																																																																																																														
0x00	0x00	0x00	0x00	0x00	0x00	0x00	0x00																																																																																																																																																																																																																																																																																														
32	33	34	35	36	37	38	39																																																																																																																																																																																																																																																																																														
0x00	0x00	0x00	0x00	0x00	0x00	0x00	0x00																																																																																																																																																																																																																																																																																														
40	41	42	43	44	45	46	47																																																																																																																																																																																																																																																																																														
0x00	0x00	0x00	0x00	0x00	0x00	0x00	0x00																																																																																																																																																																																																																																																																																														
48	49	50	51	52	53	54	55																																																																																																																																																																																																																																																																																														
0x00	0x00	0x00	0x00	0x00	0x00	0x00	0x00																																																																																																																																																																																																																																																																																														
56	57	58	59	60	61	62	63																																																																																																																																																																																																																																																																																														
0x00	0x00	0x00	0x00	0x00	0x00	0x00	0x00																																																																																																																																																																																																																																																																																														

2.10 Configuring the Monitoring of LIN Bus Signals (/VCE option)

This section explains the following settings for monitoring LIN bus signals.

Items Common to Scope Mode and Recorder Mode

- Turning waveform input on or off
- LIN frame reading settings (all sub channel settings, factor and offset settings of all sub channels, frame settings, port settings, definition file loading)
- Individual sub channel scales
- Display group
- Scaling of all sub channels
- Sample rate and sample interval settings

► “LIN Bus Signal Monitoring (/VCE option)” in the Features Guide

Channel Setup Menu

1. On the waveform screen’s **MENU**, tap **VERTICAL** > **CH**, or press **CH**. A channel setup menu appears.
(You can also tap the channel information display area at the top of the screen to display the channel setup menu.)
2. Tap a channel you want to configure, or select it using the jog dial or up and down arrow keys.

Channel setup menu (1/2)

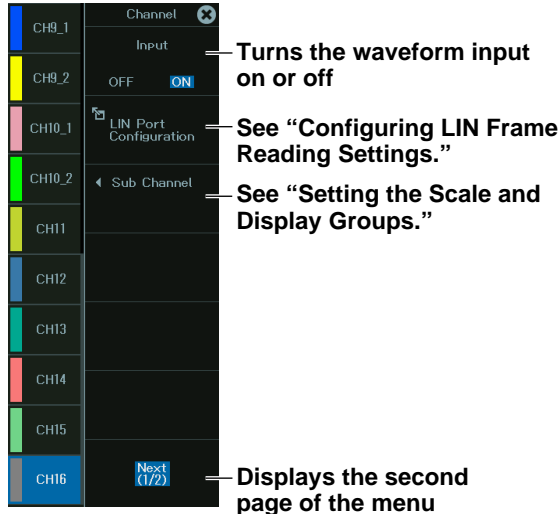

Channel setup menu (2/2)

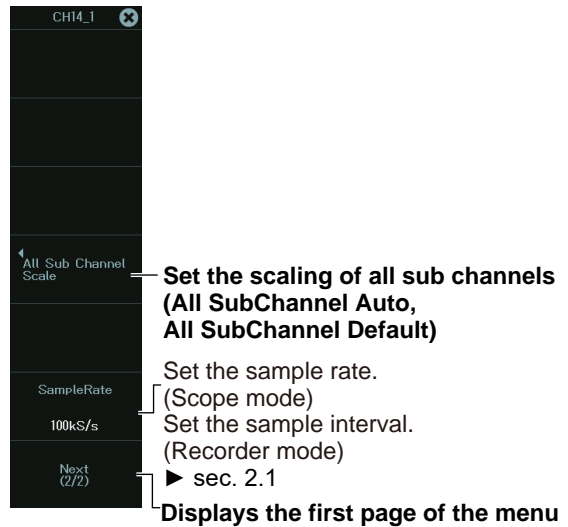

Configuring LIN Frame Reading Settings (LIN Port Configuration)

- 3 Tap **LIN Port Configuration**, or press the soft key.

All Sub Channel Setup (All SubChannel Setup - LIN Data Extraction Conditions)

4. Tap **All SubChannel Setup**, or press the soft key. The following screen appears.

Turns sub channels on or off
Set each sub channel's input to on or off.

Turns all sub channel on or off

LIN data extraction conditions

	Input	Label	ID(Hex)	Start Bit	Bit Cnt	Byte Order	Value Type
All	<input checked="" type="checkbox"/>						
1	<input checked="" type="checkbox"/>	CHI4_1	0x00	0	8	Little	Sign
2	<input checked="" type="checkbox"/>	CHI4_2	0x00	0	8	Little	Sign
3	<input checked="" type="checkbox"/>	CHI4_3	0x00	0	8	Little	Logic
4	<input checked="" type="checkbox"/>	CHI4_4	0x00	0	8	Little	Logic
5	<input checked="" type="checkbox"/>	CHI4_5	0x00	0	8	Little	Unsign
6	<input checked="" type="checkbox"/>	CHI4_6	0x00	0	8	Little	Unsign
7	<input checked="" type="checkbox"/>	CHI4_7	0x00	0	8	Little	Unsign
8	<input checked="" type="checkbox"/>	CHI4_8	0x00	0	8	Little	Unsign
9	<input checked="" type="checkbox"/>	CHI4_9	0x00	0	8	Little	Unsign
10	<input checked="" type="checkbox"/>	CHI4_10	0x00	0	8	Little	Unsign

Configuration

- All Sub Channel Set...
- All SubChannel Factor/Offset
- Port Setup
- Frame Setup
- Symbol File Load

See "Setting All Sub Channel Factor/Offset."

See "Port Setup."

See "Frame Setup."

See "Loading Definition Files."

Setting All Sub Channel Factor/Offset (All SubChannel Factor/Offset - LIN Data Conversion Condition)

4. Tap **All SubChannel Factor/Offset**, or press the soft key. The following screen appears.

LIN data conversion conditions

	Input	Label	Factor	Offset	Unit
All	<input checked="" type="checkbox"/>				
1	<input checked="" type="checkbox"/>	CHI4_1	1.0000	0.0000	
2	<input checked="" type="checkbox"/>	CHI4_2	1.0000	0.0000	
3	<input checked="" type="checkbox"/>	CHI4_3			
4	<input checked="" type="checkbox"/>	CHI4_4			
5	<input checked="" type="checkbox"/>	CHI4_5	1.0000	0.0000	
6	<input checked="" type="checkbox"/>	CHI4_6	1.0000	0.0000	
7	<input checked="" type="checkbox"/>	CHI4_7	1.0000	0.0000	
8	<input checked="" type="checkbox"/>	CHI4_8	1.0000	0.0000	
9	<input checked="" type="checkbox"/>	CHI4_9	1.0000	0.0000	
10	<input checked="" type="checkbox"/>	CHI4_10	1.0000	0.0000	

Configuration

- All Sub Channel Set...
- All SubChannel Factor/Offset
- Port Setup
- Frame Setup
- Symbol File Load

You cannot set Factor, Offset, or Unit when the data type (Value Type) is set to Logic.

Port Setup (Port Setup)

4. Tap **Port Setup**, or press the soft key. The following screen appears.



Frame Setup (Frame Setup)

4. Tap **Frame Setup**, or press the soft key. The following screen appears.

To set frames 0 to 59 to the same setting at once, change the settings in the All row.*

Set the data length.
Select the checksum method (Classic, Enhanced).

ID	Data Length	Checksum	ID	Data Length	Checksum	ID	Data Length	Checksum
All	Auto	Classic	-	-	-	-	-	-
0x00(0)	1	Classic	0x01(1)	1	Classic	0x02(2)	1	Classic
0x03(3)	1	Classic	0x04(4)	1	Classic	0x05(5)	1	Classic
0x06(6)	1	Classic	0x07(7)	1	Classic	0x08(8)	1	Classic
0x09(9)	1	Classic	0x0a(10)	1	Classic	0x0b(11)	1	Classic
0x0c(12)	1	Classic	0x0d(13)	1	Classic	0x0e(14)	1	Classic
0x0f(15)	1	Classic	0x10(16)	1	Classic	0x11(17)	1	Classic
0x12(18)	1	Classic	0x13(19)	1	Classic	0x14(20)	1	Classic
0x15(21)	1	Classic	0x16(22)	1	Classic	0x17(23)	1	Classic
0x18(24)	1	Classic	0x19(25)	1	Classic	0x1a(26)	1	Classic
0x1b(27)	1	Classic	0x1c(28)	1	Classic	0x1d(29)	1	Classic
0x1e(30)	1	Classic	0x1f(31)	1	Classic	0x20(32)	1	Classic

5. Tap each item. Use the displayed list (options) or input box to set the items.

Note

All IDs are displayed. Only the settings for the frames that have IDs that data will be read for will be enabled. The settings for frames that have other IDs will be ignored.

Loading Definition Files (Symbol File Load)

4. Tap **Symbol File Load**, or press the soft key. A file list appears.
5. On the file list, tap a symbol file (SBL file).
For details on file list operations, see section 19.10.
6. Tap **Load**. A confirmation message appears.
7. Tap **OK**. The symbol file is loaded.

Setting the Scale and Display Groups (Sub Channel)

3. After step 2 on page 2-42, tap **Sub Channel**, or press the soft key. The following screen appears.

When the Data Type (Value Type) is Unsigned or Signed

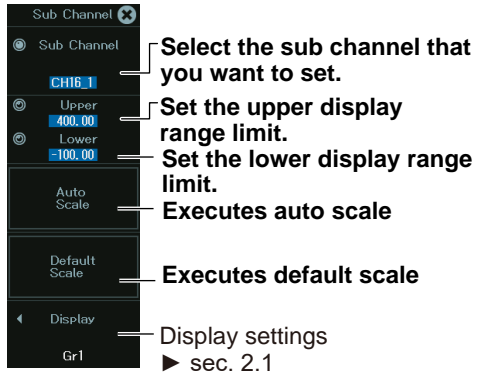

When the Data Type (Value Type) is Logic

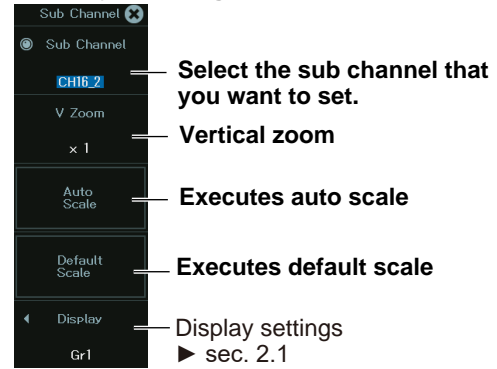

2.11 Configuring the Monitoring of SENT Signals (/VCE option)

This section explains the following settings for monitoring SENT signals.

Items Common to Scope Mode and Recorder Mode

- Turning waveform input on or off
- SENT frame reading settings (all sub channel settings, factor and offset settings of all sub channels, SENT format, error channel, input settings)
- Scale
- Display group
- Sample rate and sample interval settings

► “SENT Signal Monitoring (/VCE option)” in the Features Guide

Channel Setup Menu

1. On the waveform screen’s **MENU**, tap **VERTICAL** > **CH**, or press **CH**. A channel setup menu appears.

(You can also tap the channel information display area at the top of the screen to display the channel setup menu.)

2. Tap a channel you want to configure, or select it using the jog dial or up and down arrow keys.

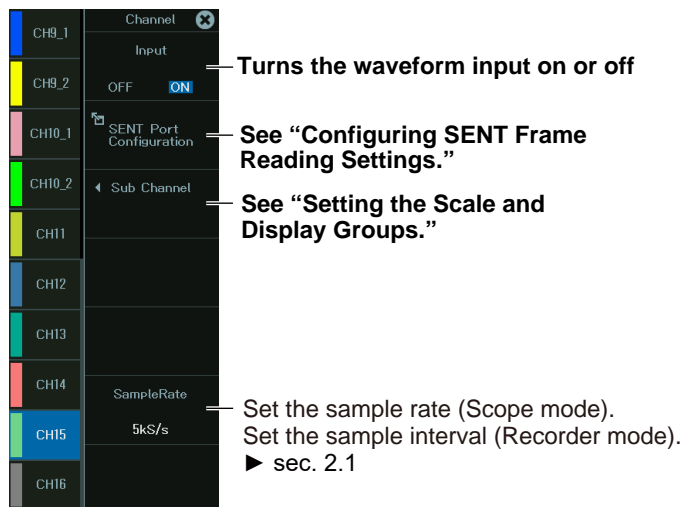

Configuring SENT Frame Reading Settings (SENT Port Configuration)

- 3 Tap **SENT Port Configuration**, or press the soft key.
All Sub Channel Setup (All SubChannel Setup - SENT Data Extraction Conditions)
- 4 Tap **All SubChannel Setup**, or press the soft key. The following screen appears.

Turns sub channels on or off
 Set each sub channel's input to on or off.
 If the data type is S&C, turn the display on or off for each bit.

SENT data extraction conditions

		Data Type	Input	Label	ID	Endian	Start Bit	Bit Size	Value Type
1		FastCH	ON	CHI6_F1		Big	0	12	Unsigned
2		FastCH	ON	CHI6_F2		Big	12	12	Unsigned
3		FastCH	ON	CHI6_F3		Big	0	12	Unsigned
4		S&C	ON	CHI6_SC					
	_1		ON	Bit0					
	_2		ON	Bit1					
	_3		ON	Bit2					
	_4		ON	Bit3					
5		SlowCH	ON	CHI6_S1	0x00		0	12	Unsigned
6		SlowCH	ON	CHI6_S2	0x00		0	12	Unsigned
7		SlowCH	ON	CHI6_S3	0x00		0	12	Unsigned
8		SlowCH	ON	CHI6_S4	0x00		0	12	Unsigned
9		SlowCH	ON	CHI6_S5	0x00		0	12	Unsigned
10		Error Trigger	ON	CHI6_ET					
11		Error Count	ON	CHI6_EC					

Configuration

All Sub Channel Set...

All SubChannel Factor/Offset

SENT Format Setup

Error Channel Setup

Input Setup

See "Setting All Sub Channel Factor/Offset."

See "Setting the SENT Format."

See "Setting Error Channels."

See "Input Setup."

Setting All Sub Channel Factor/Offset (All SubChannel Factor/Offset - SENT Data Conversion Condition)

- 4 Tap **All SubChannel Factor/Offset**, or press the soft key. The following screen appears.

SENT data conversion conditions

		Data	Input	Label	Factor	Offset	Unit
1		FastCH	ON	CHI6_F1	1.0000	0.0000	
2		FastCH	ON	CHI6_F2	1.0000	0.0000	
3		FastCH	ON	CHI6_F3	1.0000	0.0000	
4		S&C	ON	CHI6_SC			
	_1		ON	Bit0			
	_2		ON	Bit1			
	_3		ON	Bit2			
	_4		ON	Bit3			
5		SlowCH	ON	CHI6_S1	1.0000	0.0000	
6		SlowCH	ON	CHI6_S2	1.0000	0.0000	
7		SlowCH	ON	CHI6_S3	1.0000	0.0000	
8		SlowCH	ON	CHI6_S4	1.0000	0.0000	
9		SlowCH	ON	CHI6_S5	1.0000	0.0000	
10		Error Trigger	ON	CHI6_ET			
11		Error Count	ON	CHI6_EC			

Setting the SENT Format (SENT Format Setup)

4. Tap **SENT Format Setup**, or press the soft key. The following screen appears.

The screenshot shows the 'SENT Format Setup' screen with the following settings and annotations:

- Clock Tick:** 3.00us. Annotation: Set the clock tick (1.00 to 100.00 μs).
- Data Nibble Number:** 6. Annotation: Set the number of data nibbles of Fast CH messages (1 to 8).
- Pause Pulse:** ON. Annotation: Set whether to include pause pulses in Fast CH messages (ON or OFF).
- CRC Type:** Recommended. Annotation: Set the CRC method (Legacy, Recommended).
- SlowCH Type:** Enhanced(ID 8bit + Data 12bit). Annotation: Set the Slow CH message format. (Short(ID 4bit + Data 8bit), Enhanced(ID 8bit + Data 12bit), Enhanced(ID 4bit + Data 16bit))
- Fast Channel Multiplexing:** OFF. Annotation: Turns Fast Channel Multiplexing on or off. You can set this when the SENT monitor module version is 0x07 or later.

Setting Error Channels (Error Channel Setup)

4. Tap **Error Channel Setup**, or press the soft key. The following screen appears.

The screenshot shows the 'Error Channel Setup' screen with the following settings and annotations:

- Successive Calibration Pulses (Option2) only:** Error detection (Detect) is always on for Fast Channel CRC, Slow Channel CRC, Nibble Value, and Pulse Number.
- Turns error detection on or off (Successive Calibration Pulses (Option2) only):** Points to the 'Detect' column.
- Turns error trigger display on or off:** Points to the 'Error Trigger' column.
- Turns error count integration on or off:** Points to the 'Error Count' column.
- Turns error count reset on start on or off:** Points to the 'Error Count Reset on Start' setting (ON).
- Executes the manual resetting of the error count:** Points to the 'Execute' button.

	Detect	Error Trigger	Error Count
Fast Channel CRC	ON	ON	ON
Slow Channel CRC	ON	ON	ON
Nibble Value	ON	ON	ON
Successive Calibration Puls...	OFF	ON	ON
Pulse Number	ON	ON	ON

Input Setup (Input Setup)

4. Tap **Input Setup**, or press the soft key. The following screen appears.

The screenshot shows the 'Input Setup' screen with the following settings and annotations:

- Probe:** 1:1. Annotation: Set the probe (1:1, 10:1).
- Threshold H:** 3.5V. Annotation: Upper threshold (fixed).
- Threshold L:** 1.5V. Annotation: Lower threshold (fixed).
- Time Out:** 2000.0ms. Annotation: Set the timeout value (0.1 to 2000.0ms).

Setting the Scale and Display Groups

3. Tap **Sub Channel**, or press the soft key. The following screen appears.

When the sub channel is 4:S&C (SC) or 10:ErrorTrig (ET)

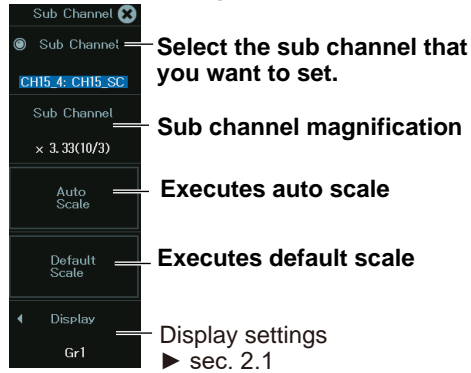

Select the sub channel that you want to set.

Sub channel magnification

Executes auto scale

Executes default scale

Display settings
► sec. 2.1

When the sub channel is not 4:S&C (SC) or 10:ErrorTrig (ET)

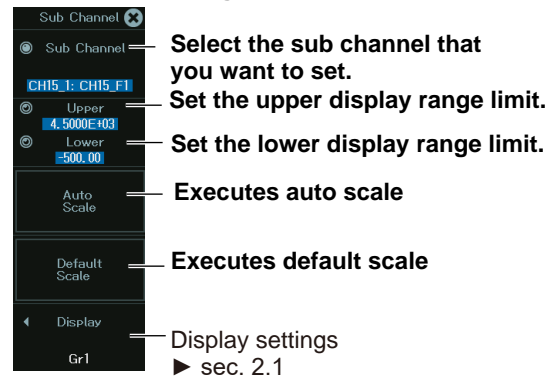

Select the sub channel that you want to set.

Set the upper display range limit.

Set the lower display range limit.

Executes auto scale

Executes default scale

Display settings
► sec. 2.1

The types of data acquired in sub channels are as follows.

Sub Channel	Data Type
1: FastCH	
2: FastCH	FastCH
3: FastCH	
4: S&C	S&C (Stauts & Communication)
	When Fast Channel Multiplexing is on*
5: SlowCH	5: SlowCH/FastCH
6: SlowCH	6: SlowCH/FastCH
7: SlowCH	7: SlowCH/FastCH
8: SlowCH	8: SlowCH/FastCH
9: SlowCH	9: SlowCH/FastCH
10: Error Trigger	Error Trigger
11: Error Count	Error Count

* For details on Fast Channel Multiplexing, see "Setting the SENT Format (SENT Format Setup)."

2.12 Displaying the All Channel Setup Menu

This section explains the following settings for configuring all channels:

Items Common to Scope Mode and Recorder Mode

- Turning waveform input on and off
- Input settings
- Linear scaling
- Real time math channels (/G03, /G05 option)
- Copying channels
- Strain balancing (strain module) and DC offset cancellation

► “Displaying the Menu for Configuring All Channels (ALL CH)” in the Features Guide

All channel setup menu

1. On the waveform screen’s **MENU**, tap **VERTICAL** > **All CH**, or press **ALL CH**. An all channel setup menu appears.

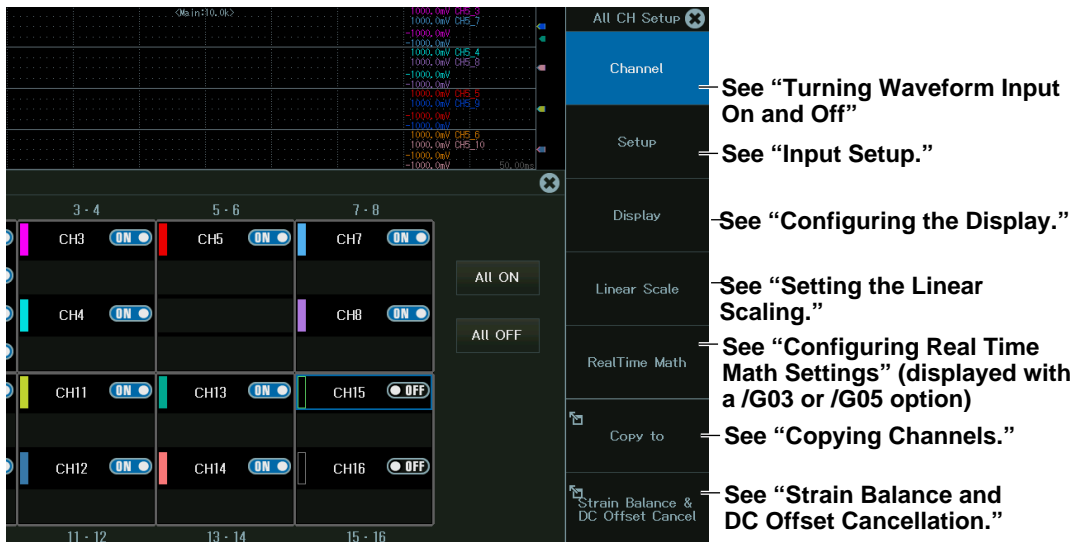

Turning Waveform Input On and OFF

2. Tap **Channel**, or press the soft key.

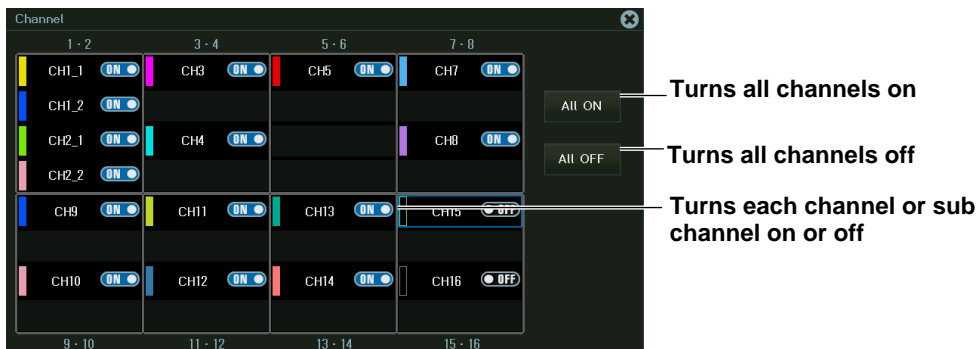

Input Setup (Setup)

2. Tap **Setup**, or press the soft key. The following screen appears.
The items on the input setting screen vary depending on the installed modules and measurement items. For details on the settings, see the explanation of the measurement items in section 2.1 and later.
3. Tap the items of each channel. Use the displayed list (options) or input box to set the items.

Turns waveform input on for all channels

Turns the waveform input on or off

Turns waveform input off for all channels

Display label

Input coupling

Vertical scale

Bandwidth limit

Probe attenuation, current-to-voltage conversion ratio, or bridge voltage (for strain measurement)

Gauge factor (for strain measurement)

		Input	Label	Coupling	V Scale	Band Width	Probe	
1	1		ON	CH1_1	DC	50V/div	Full	10:1
	2		ON	CH1_2	DC	50V/div	Full	10:1
2	1		ON	CH2_1	DC	50V/div	Full	10:1
	2		ON	CH2_2				
3			ON	CH3				
4			ON	CH4	DC	50V/div	Full	10:1
5	+		ON					

Scroll to display channels that do not fit in the screen.

Configuring the Display (Display)

2. Tap **Display**, or press the soft key. The following screen appears.
For details on the settings, see the explanation of the measurement items in section 2.1 and later.
3. Tap the items of each channel. Use the displayed list (options) or input box to set the items.

Scope Mode

Turns waveform input on for all channels

Turns the waveform input on or off

Turns waveform input off for all channels

Display label

Vertical scale

Offset

Vertical position

Set the zoom magnification.

Sample rate

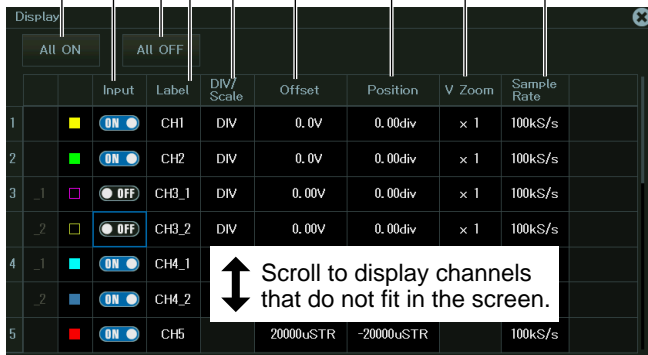

Recorder Mode

Turns waveform input on for all channels

Turns the waveform input on or off

Turns waveform input off for all channels

Display label

Upper and lower limits of the display range

Sample interval

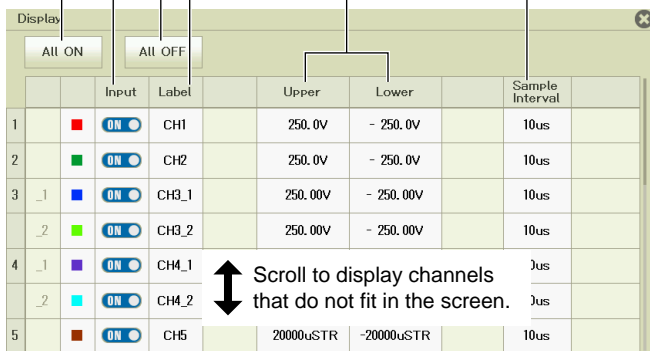

Setting the Linear Scaling (Linear Scale)

2. Tap **Linear Scale**, or press the soft key. The following screen appears.
For details on the settings, see the explanation of the measurement items in section 2.1 and later.
3. Tap the items of each channel. Use the displayed list (options) or input box to set the items.

Linear scaling mode

Scaling coefficient A or measured value at point P1
Offset value B or scaled value of point P1
Measurement value of point P2
Scaled value of point P2
Display mode
Unit
Number of decimal places
Unit prefix

Linear Scale	AX+B:A P1-P2	AX+B:B P1XP1-P2 P1:Y	P1-P2	P2:XP1-P2	P2:Y	Unit	Disp Type	Decim Num	Sub Unit
1	AX+B	25.000	-25.000				Exp		
2	P1-P2	1.0000	0.0000	5.0000	100.00		Exp		
3	_1	OFF							
	_2	OFF							
4	_1	OFF							
	_2	OFF							
5	_1	OFF							
	_2	OFF							

Slide to display channels that do not fit in the screen.

Configuring Real Time Math Settings (RealTime Math) (/G03, /G05 option)

2. Tap **RealTime Math**, or press the soft key. The following screen appears.
3. Tap the items of each channel. Use the displayed list (options) or input box to set the items.
For details on real time math, see chapter 16.

Turns real time math on or off
Display label
Equation
Source channels
Constants

RMath	Label	Operation	Source1	Source2	A	B
1	RTmath1	A(S1)+B(S2)+C	CH1	CH2	1.0000	1.0000
2	RTmath2	A(S1)+B(S2)+C	CH1	CH2	1.0000	1.0000
3	RTmath3	A(S1)+B(S2)+C	CH1	CH2	1.0000	1.0000
4	RTmath4	A(S1)+B(S2)+C	CH1	CH2	1.0000	1.0000
5	RTmath5	A(S1)+B(S2)+C	CH1	CH2	1.0000	1.0000
6	RTmath6					1.0000
7	RTmath7					
8	RTmath8					

Slide to display channels that do not fit in the screen.

Copying Channels (Copy to)

2. Tap **Copy to**, or press the soft key. The following screen appears.

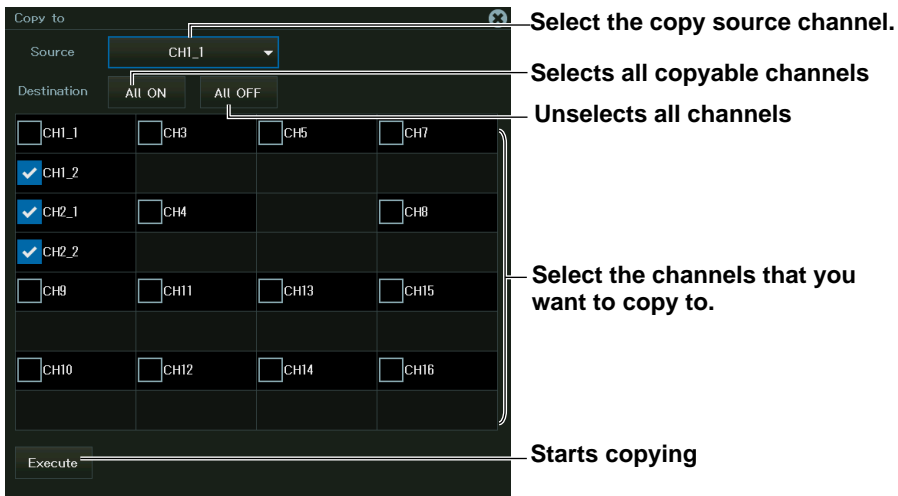

Strain Balance and DC Offset Cancellation (Balance & DC Offset Cancel)

2. Tap **Strain Balance & DC Offset Cancel**, or press the soft key. The following screen appears.

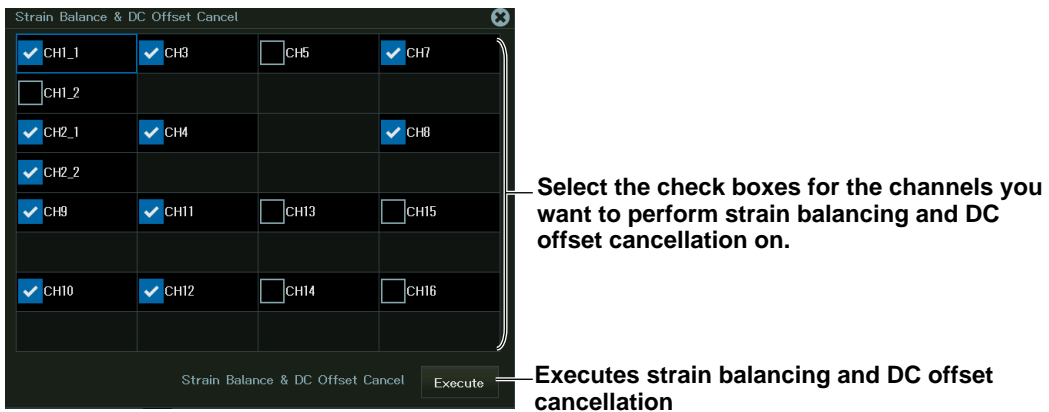

2.13 Setting the Digital Filter (/G03, /G05 option)

On models with the /G03 or /G05 option, in addition to the bandwidth limit, you can set a digital filter (some input modules do not support the digital filter).

Items Common to Scope Mode and Recorder Mode

Digital filter settings

► “Digital Filter (Filter) (/G03, /G05 option)” in the Features Guide

Channel Setup Menu

1. On the waveform screen's **MENU**, tap **VERTICAL** > **CH**, or press **CH**. A channel setup menu appears.
(You can also tap the channel information display area at the top of the screen to display the channel setup menu.)
2. Tap a channel you want to configure, or select it using the jog dial or up and down arrow keys.

Digital filter settings

3. Tap **Filter**, or press the soft key. A filter setup menu appears.
“Filter” does not appear for channels without digital filters. Either “Bandwidth Limit” is displayed, or nothing is displayed.

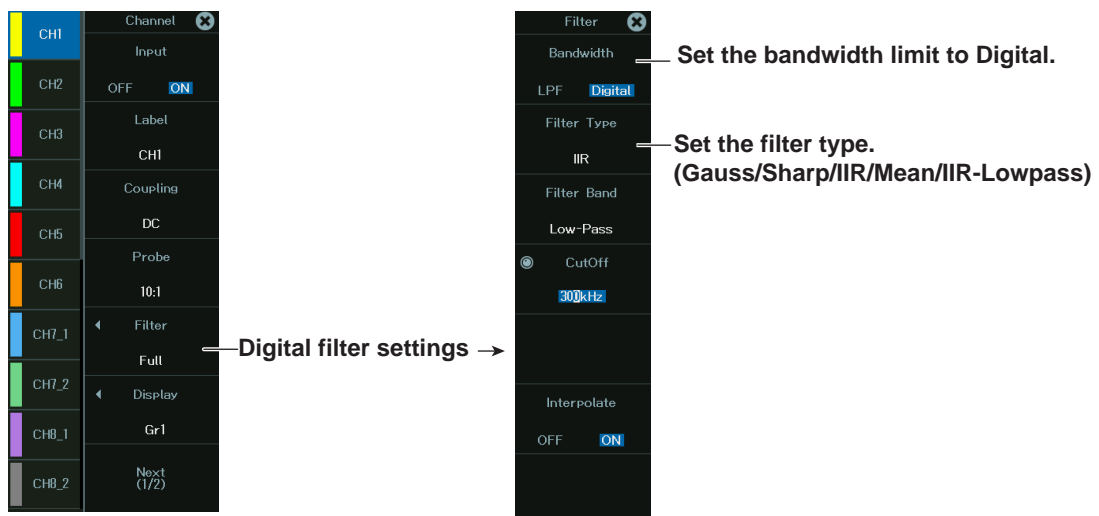

4. Set **Bandwidth** to **Digital**.

Set the filter type.

Setting the Gauss, Sharp, IIR, or IIR-Lowpass Filter

5. Tap **Filter Type**, or press the soft key. A Filter Type setup menu appears.

When Filter Band is set to Low-Pass or High-Pass

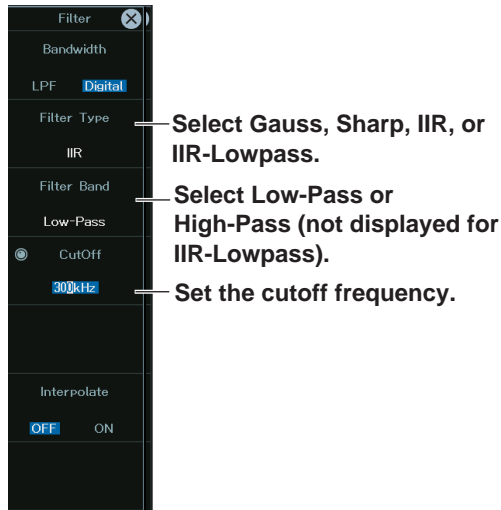

When Filter Band is set to Band-Pass

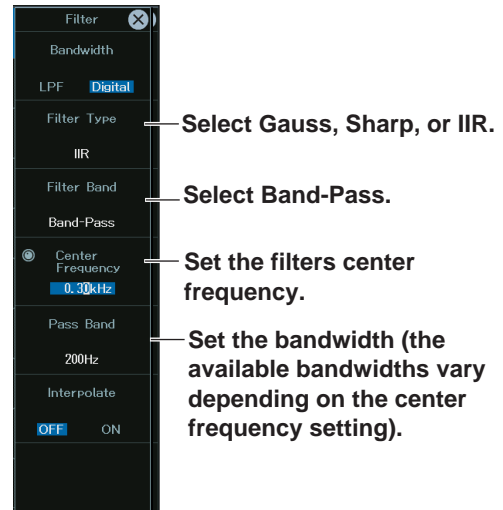

For Band-Pass, set the center frequency and the bandwidth, the frequencies before and after the center frequency.

Setting the Moving Average (Mean)

5. Set Filter Type to Mean.

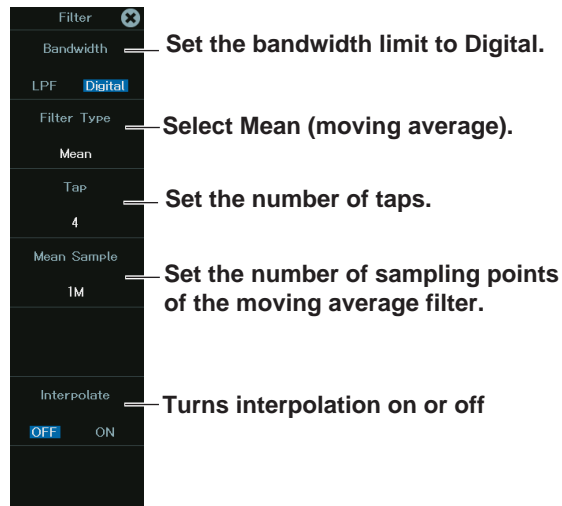

Chapter 3

Waveform Acquisition

Main Control Areas Used in This Chapter

You can also use the touch panel.

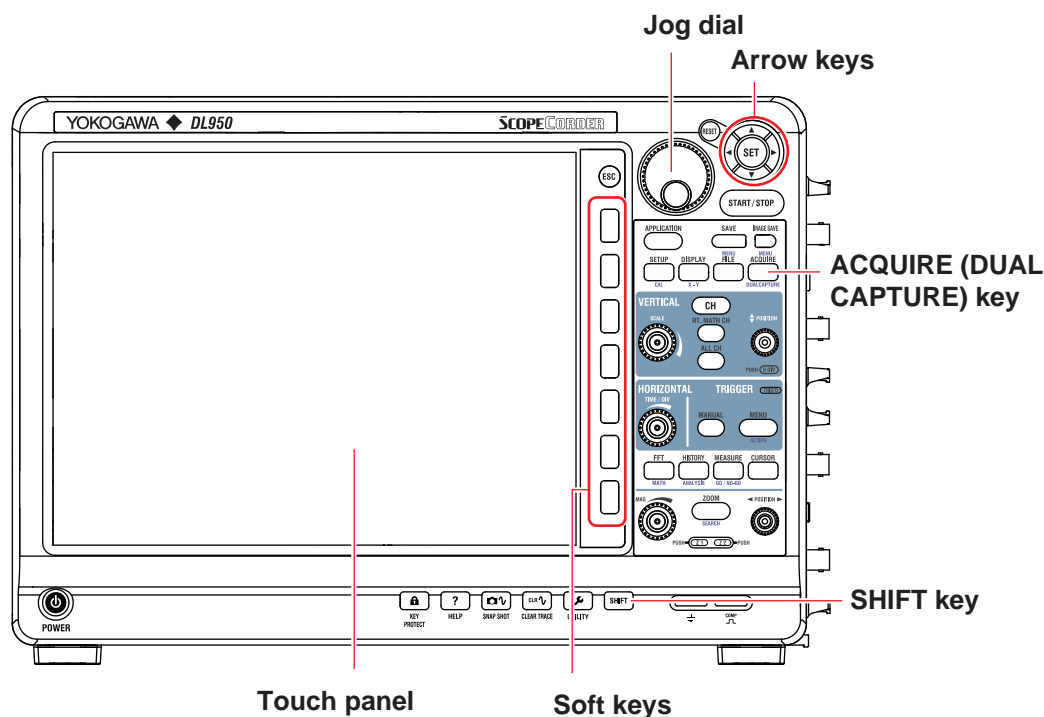

Operation Modes Applicable to the Sections in This Chapter

✓: Applicable, -: Not applicable

Section	Scope Mode	Recorder Mode
3.1 Setting Conditions for Waveform Acquisition (Scope mode)	✓	-
3.2 Setting Conditions for Waveform Acquisition (Recorder mode)	-	✓
3.3 Starting and Stopping Waveform Acquisition	✓	✓
3.4 Using the Dual Capture Feature (Scope mode only)	✓	-
3.5 Performing Real-time Recording (SSD Recording) (/ST1 option)	✓	✓

* The settings may vary depending on the operation mode.

3.1 Setting Conditions for Waveform Acquisition (Scope mode)

This section explains the following settings for acquiring waveforms in Scope mode:

Applicable in Scope Mode (dual capture mode off)

- Record length
- Acquisition mode
- Trigger mode
- Waveform acquisition count
- Time base
- Time scale setting

► [“Waveform Acquisition” in the Features Guide](#)

ACQUIRE menu

1. On the waveform screen’s **MENU**, tap **ACQUIRE** > **ACQUIRE**, or press **ACQUIRE**. The ACQUIRE menu appears.

When the dual capture mode is on, the dual capture menu appears. See section 3.4, “Using the Dual Capture Feature (Scope mode only).”

When the Acquisition Mode Is Set to Normal or Envelope

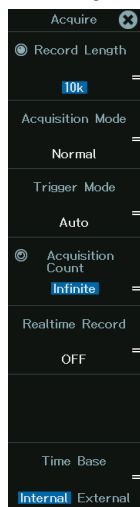

Record Length — Set the record length.

Acquisition Mode — Set the acquisition mode to Normal (normal) or Envelope (envelope).

Trigger Mode — Set the trigger mode.

Acquisition Count — Set the number of waveform acquisitions.*

Realtime Record — Set real-time recording. ► sec. 3.5 (/ST1 option)

Time Base — Set the time base (Internal, External).

External — Set the pulse/rotation.

When the trigger mode is set to Single N

* When SSD Recording is off or when the trigger mode is set to Auto, AutoLevel, or Normal

When the Acquisition Mode Is Set to Average

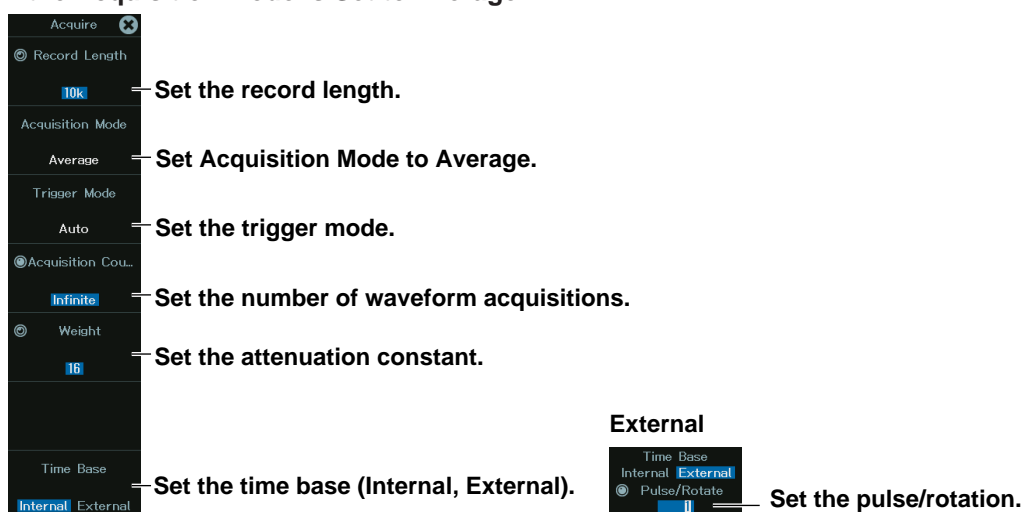

Setting the Acquisition Mode (Acquisition Mode)

- Normal: Displays waveforms without processing the sampled data. Set the waveform acquisition count.
- Envelope: Displays waveforms in envelope mode. Set the waveform acquisition count.
- Average: Displays averaged waveforms. Set the attenuation constant or the number of times to average.
When the acquisition mode is set to Average, the trigger mode cannot be set to Single, Single N, or On Start.
SSD recording cannot be used either.

Setting the Trigger Mode (Trigger Mode)

The trigger mode determines the conditions for updating the displayed waveforms. The operation is the same as for Trigger Mode of the MENU key for trigger.

► sec 4.1 for trigger)

You can select from the following options.

Auto, AutoLevel, Normal, Single, Single N, On Start

Setting the Time Base (Time Base)

- Internal: The internal clock signal is used for the time base (the TIME/DIV setting is valid).
- External: An external clock signal is used for the time base (the TIME/DIV setting is invalid).
Specify a pulse count that corresponds to one rotation (or one cycle) of mechanical movement (Pulse/Rotate).

Setting the Time Scale

Turn the TIME/DIV knob. The new TIME/DIV will be applied the next time waveform acquisition is started.

3.2 Setting Conditions for Waveform Acquisition (Recorder mode)

This section explains the following settings for acquiring waveforms in Recorder mode:

Applicable in Recorder Mode

- Recording time
- Sample interval
- Acquisition method
- Acquisition mode
- Time base

► [“Waveform Acquisition” in the Features Guide](#)

ACQUIRE menu

1. On the waveform screen’s **MENU**, tap **ACQUIRE > ACQUIRE**, or press **ACQUIRE**. The ACQUIRE menu appears.

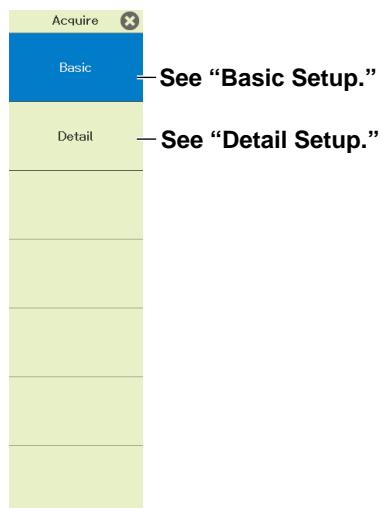

Basic Setup (Basic)

2. Tap **Basic**, or press the soft key. The following screen appears.

Recording time

Sample interval
Slide to display sample intervals that do not fit in the screen.

Acquisition conditions
Select from the following three options.
Acquisition Time (specified acquisition time)
Continuous (continuous acquisition)
Capture on Trigger (triggered acquisition)
When the acquisition method is set to SSD Recording, this is fixed to Acquisition Time.

Acquisition method
Select from the following three methods.
Memory
Memory + Save on Stop
SSD Recording

With the time base in detail setup (Detail) is set to external clock signal.

Record length
Scroll to display record lengths that do not fit in the screen.

Setting the Acquisition Conditions

Set when to start or stop waveform acquisition when the START/STOP button is pressed.

Acquisition Time: Waveform acquisition starts when the START/STOP button is pressed. When the specified time elapses, waveform acquisition stops automatically.

Continuous: Waveform acquisition starts when the START/STOP button is pressed. When the button is pressed again, acquisition stops.

Capture on Trigger: When you press the START/STOP button, the instrument enters the trigger-wait state. Waveform acquisition starts when a trigger occurs. When the specified time elapses, waveform acquisition stops automatically.
Specify this when you want to start waveform acquisitions with triggers.

Setting the Acquisition Method

Set the waveform data acquisition method.

Memory: Waveform data is saved in the internal memory. The data is cleared when waveform data acquisition starts again or when the power is turned off.

Memory + Save on Stop: Waveform data is saved and the internal memory. After acquisition stops, the data is saved in the SSD or USB memory. The data saved in the internal memory is cleared when waveform data acquisition starts again or when the power is turned off.

SSD Recording: Waveform data is saved in the SSD. This is valid on models with the /ST1 option.

Detail Setup (Detail)

2. Tap **Detail**, or press the soft key. The following screen appears.

When Acquisition Method Is Set to Memory

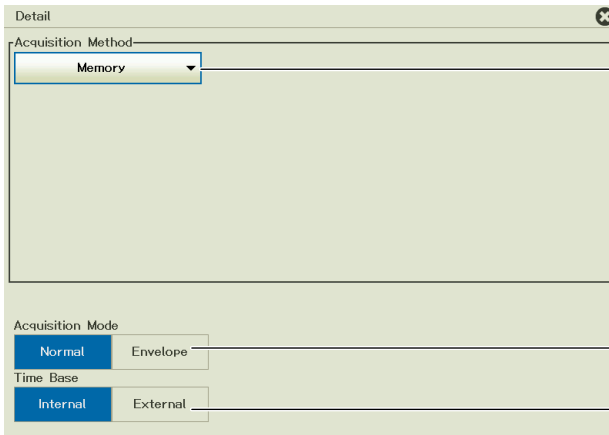

Set the acquisition method.
Select Memory.

Set the acquisition mode.
▶ sec. 3.1

Set the time base.

When the time base is External

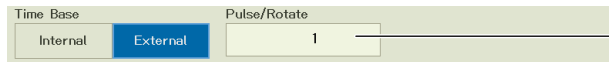

Set the pulse count or rotation count.

When Acquisition Method Is Set to Memory + Save on Stop

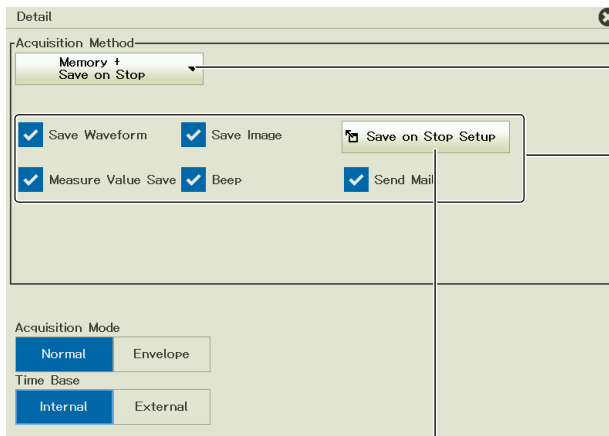

Set the acquisition method.
Select Memory + Save on Stop.

Set action to perform when data acquisition is completed.

Detail setup

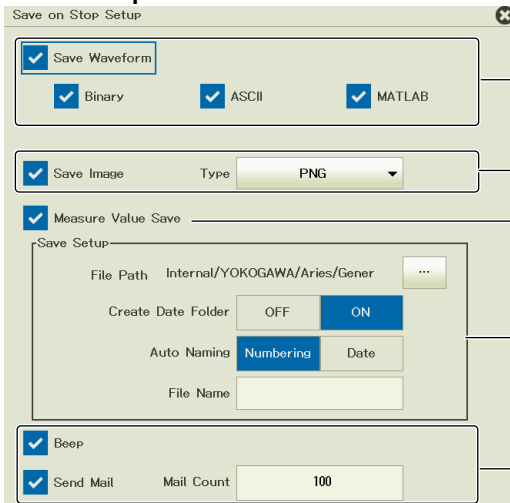

Turn waveform data saving on or off, and set the data format.

Turn image data saving on or off, and set the data format.

Turns waveform parameters saving on or off

Set the save destination and the file name for waveform parameters.

Turns beep sound and mail transmission on or off

Data Saved When Data Acquisition Is Complete and the Operation Performed

- Binary: Waveform data is saved in WDF format.
- ASCII: Waveform data is saved in ASCII format.
- MATLAB: Waveform data is saved in MATLAB format.
- Save Image: Screen capture data is saved (PNG, BMP, JPEG).
- Measure Value Save: Waveform parameter measurement values are saved.
- Beep: A beep sound is generated.
- Send Mail: A mail message is sent.

When Acquisition Method Is Set to SSD Recording (/ST1 option)

Set the acquisition method.
Select SSD Recording.

Set the file name.

Set the file division.

Set the number of file divisions.

Set the item to append to the file name.

Set a comment.

3.3 Starting and Stopping Waveform Acquisition

Items Common to Scope Mode and Recorder Mode

Start/Stop mode

▶ [“Waveform Acquisition \(START/STOP\)” in the Features Guide](#)

Waveform Acquisition (START and STOP)

1. On the waveform screen's **MENU**, tap **START/STOP**, or press **START/STOP**. The instrument starts or stops waveform acquisition.

The key is illuminated while the instrument is acquiring waveforms.

3.4 Using the Dual Capture Feature (Scope mode only)

This section explains the following settings when acquiring waveforms with the dual capture feature.

Applicable in Scope Mode

- Low-speed sampling waveform settings (horizontal scale, record length, acquisition mode, SSD recording)
- High-speed sampling waveform settings (horizontal scale, record length)
- Action to perform after waveforms are acquired
- Display format
- Percentage of the screen that the main waveform occupies
- Zoom factor
- List display

► “Dual Capture (DUAL CAPTURE, Scope mode only)” in the Features Guide

DUAL CAPTURE Menu

1. On the waveform screen’s **MENU**, tap **ACQUIRE > DUALCAPTURE**, or press **SHIFT+ACQUIRE(DUAL CAPTURE)**. A dual capture menu appears.

When dual capture is on, you can also display the dual capture menu by tapping **ACQUIRE > Acquire** on the waveform screen’s **MENU**, or pressing **ACQUIRE**.

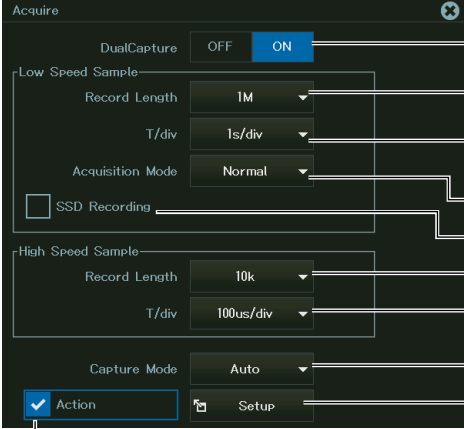

The screenshot shows the 'Acquire' menu with the following settings and callouts:

- DualCapture**: OFF / ON (Set Mode to ON.)
- Low Speed Sample**:
 - Record Length**: 1M (Set the horizontal scale for low-speed sampling (main).)
 - T/div**: 1s/div (Set the record length for low-speed sampling (main).)
 - Acquisition Mode**: Normal (Set the acquisition mode (Normal, Envelope).)
 - SSD Recording**: (Turns SSD recording on or off ► sec. 3.5)
- High Speed Sample**:
 - Record Length**: 10k (Set the record length for high-speed sampling.)
 - T/div**: 100us/div (Set the horizontal scale for high-speed sampling.)
 - Capture Mode**: Auto (Set the capture mode (Auto, On Start).)
- Action**: (Set the action. ► sec. 15.1)
- Setup**: (Turn actions on or off)

Note

When dual capture is on, the acquisition mode cannot be set to Average.

Note that the acquisition mode set here is applied to the settings in section 3.1.

3.4 Using the Dual Capture Feature (Scope mode only)

Capture Mode (Capture Mode)

Set when to start or stop waveform acquisition when the START/STOP button is pressed.

There are two capture modes: Auto and On Start.

Auto (Auto): Low-speed sampling and high-speed sampling waveforms are acquired from when acquisition is started until it is stopped. In high-speed sampling, when the acquirable history waveform data is acquired, old history waveforms are overwritten in order.

On Start (On Start): In low-speed sampling, when the specified record length of data or 10 divisions of data is acquired after starting waveform acquisition, waveform acquisition stops. In high-speed sampling, when the acquirable history waveform data is acquired, waveform acquisition stops.

Display Format (Format)

1. With dual capture turned on, on the waveform screen's **MENU**, tap **DISPLAY > DISPLAY**, or press **DISPLAY**. The Display menu appears.
2. Tap **Format**, or press the soft key.

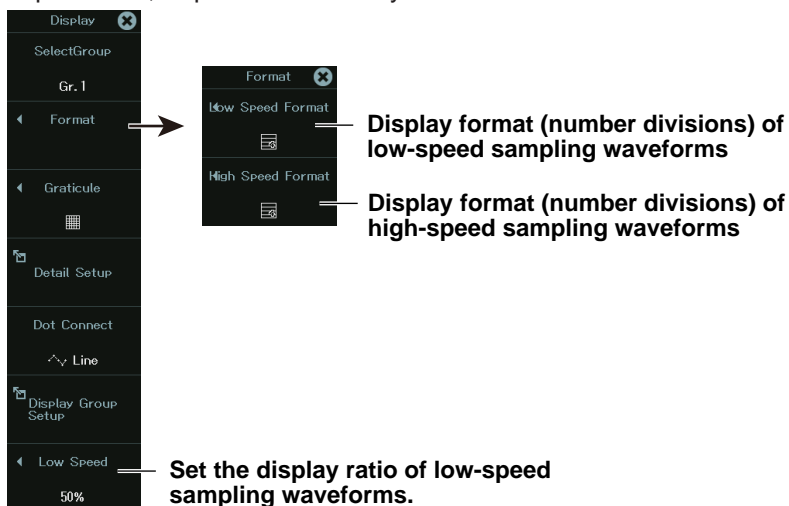

3. Set the display format (number divisions) for low-speed sampling and high-speed sampling. For details on the display format and other settings, see chapter 5, "Display."

Configuring the Waveform Display Area

2. Tap **Low Speed**, or press the soft key.
3. Set the percentage of the entire waveform display area that the low-speed sampling waveform will occupy.

ZOOM

For details on zoom, see chapter 7, “Zooming In on or Out of Waveforms.”

1. With dual capture turned on, on the waveform screen’s **MENU**, tap **ANALYSIS > ZOOM**, or press **ZOOM**. The Zoom menu appears.

Low-speed sampling ZOOM menu (1/2)

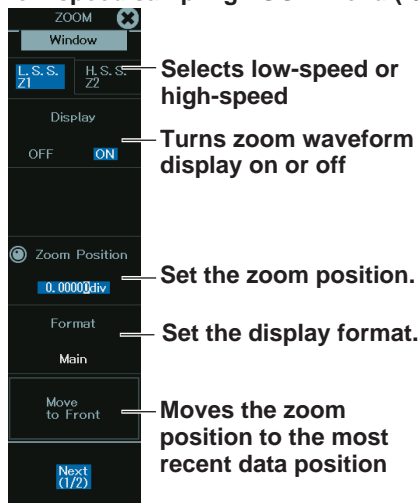

Low-speed sampling ZOOM menu (2/2)

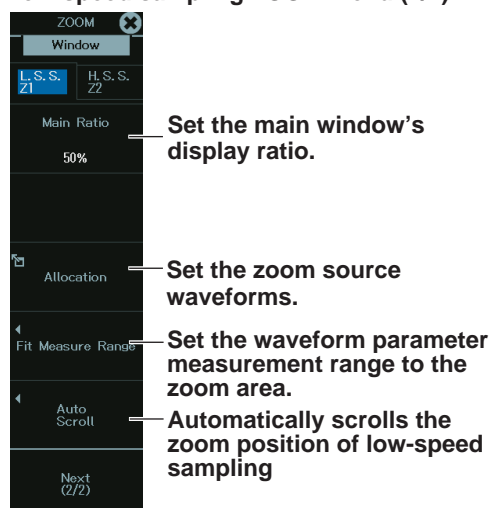

High-speed sampling ZOOM menu (1/2)

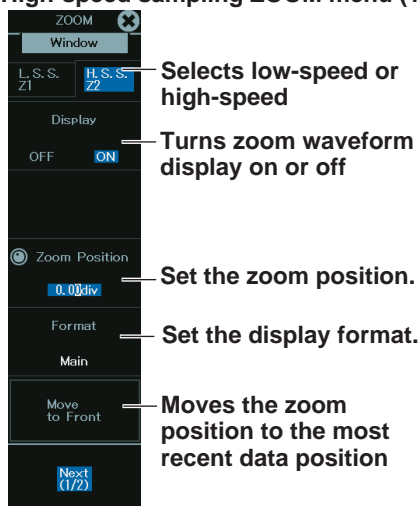

High-speed sampling ZOOM menu (2/2)

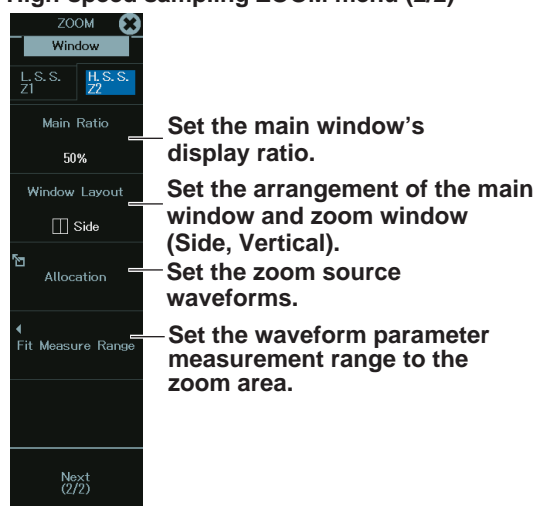

2. Set the zoom waveforms for low-speed sampling and high-speed sampling.

List Display

1. With dual capture turned on, on the waveform screen's **MENU**, tap **ANALYSIS > HISTORY**, or press **HISTORY**. The History menu appears.

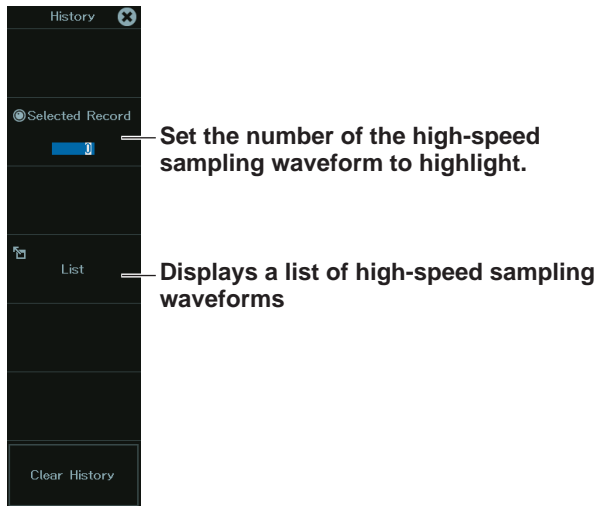

3.5 Performing Real-time Recording (SSD Recording) (/ST1 option)

This section explains the following settings when acquiring waveforms with the real-time recording (SSD recording) feature.

Items Common to Scope Mode and Recorder Mode

- Turning SSD recording on and off
- Save destination and file name for recorded data
- File division

► **“Waveform Acquisition” and “SSD Recording (SSD Recording, /ST1 option)” in the Features Guide**

Scope Mode

ACQUIRE Menu (when dual capture is off)

1. On the waveform screen’s MENU, tap **ACQUIRE > ACQUIRE**, or press **ACQUIRE**. The ACQUIRE menu appears.

When the dual capture mode is on, the dual capture menu appears. See section 3.4, “Using the Dual Capture Feature (Scope mode only).”

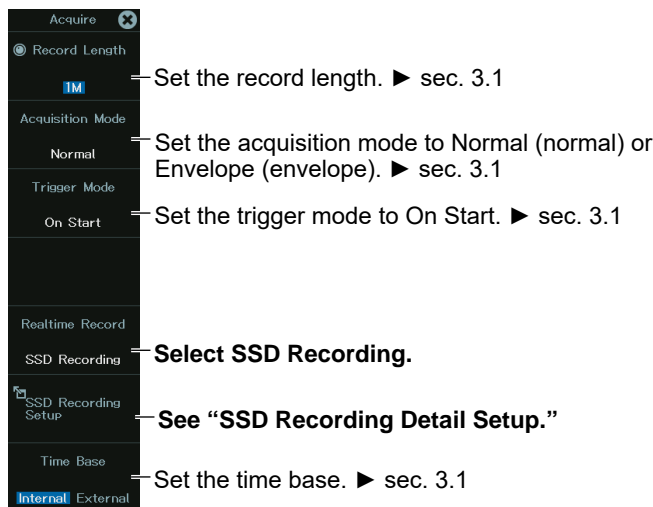

SSD Recording Detail Setup (SSD Recording Detail Setup)

2. Press the **SSD Recording Detail Setup** soft key. The following menu appears.

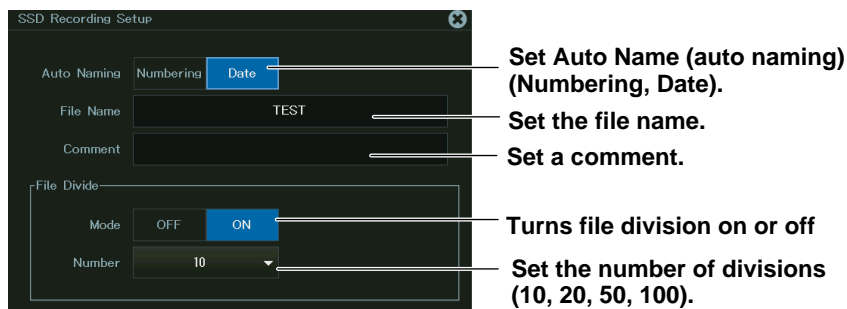

ACQUIRE Menu (when dual capture is on)

1. On the waveform screen's MENU, tap **ACQUIRE > DUALCAPTURE**, or press **SHIFT+ACQUIRE(DUAL CAPTURE)**. A dual capture menu appears.

You can also display the dual capture menu by tapping **ACQUIRE > ACQUIRE** on the waveform screen's **MENU**, or pressing **ACQUIRE**.

The screenshot shows the 'Acquire' menu with the following settings and callouts:

- DualCapture:** OFF / ON (Callout: Turns SSD recording on or off)
- Low Speed Sample:**
 - Record Length: 1M
 - T/div: 1s/div
 - Acquisition Mode: Normal
 - SSD Recording: (Callout: Configure SSD recording. See "SSD Recording Detail Setup.")
 - Setup:
- High Speed Sample:**
 - Record Length: 10k
 - T/div: 100us/div
- Capture Mode:** On Start (Callout: To perform SSD recording, set the capture mode to On Start.)
- Action:** (Callout: To perform SSD recording, set action to OFF.)

The file name and file division settings when dual capture is off are valid.

Note

SSD recording can be performed only on the low-speed sampling waveform when dual capture is on.

Recorder Mode

ACQUIRE menu

1. On the waveform screen's MENU, tap **ACQUIRE > ACQUIRE**, or press **ACQUIRE**. The ACQUIRE menu appears.

The screenshot shows the 'Acquire' menu with the following options and callouts:

- Basic:** (Callout: See "Basic Setup.")
- Detail:** (Callout: See "Detail Setup.")

Basic Setup (Basic)

2. Tap **Basic**, or press the soft key. The following screen appears.

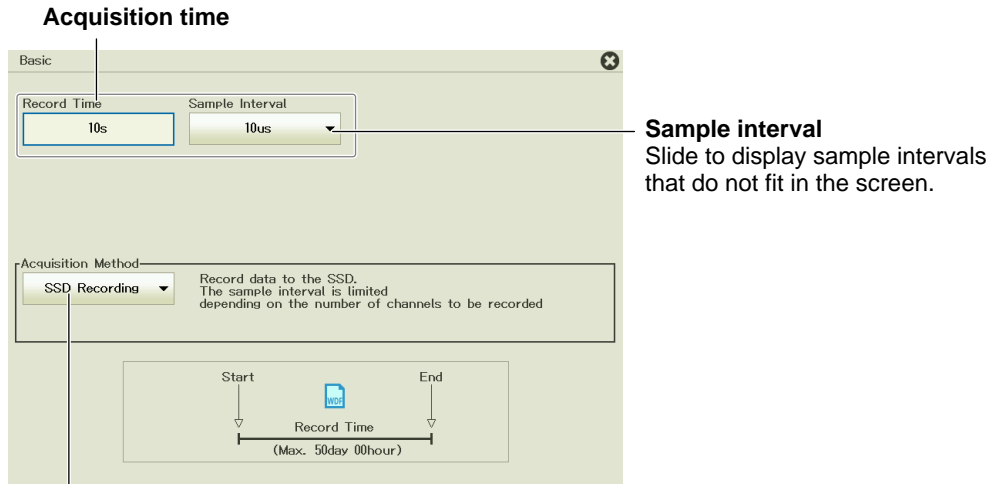

Set the acquisition method to SSD Recording.

Detail Setup (Detail)

3. Tap **Detail**, or press the soft key. The following screen appears.

Set the acquisition method.
Select SSD Recording.

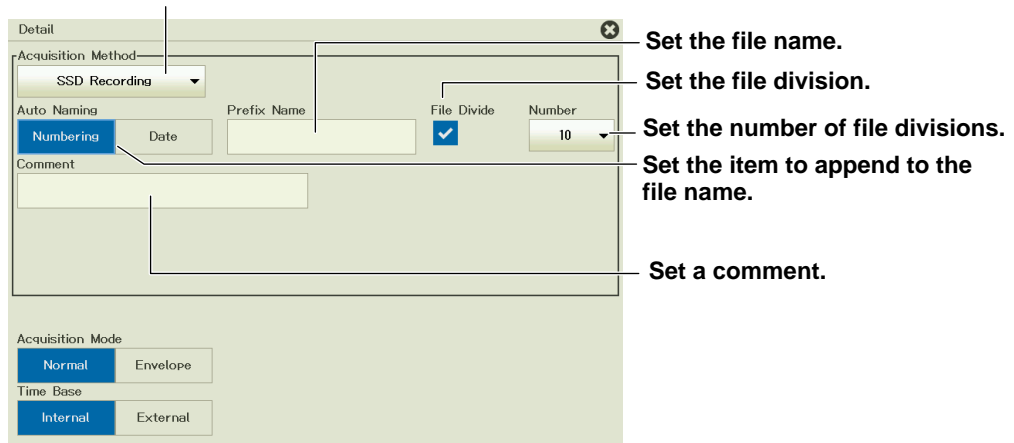

SSD Recording (START/STOP)

Press **START/STOP**. Waveform acquisition and SSD recording start. Press **START/STOP** again to stop waveform acquisition. Even if the set recording time has not been exceeded, SSD recording will stop.



CAUTION

- If the power supply is interrupted during SSD recording, the SSD may be damaged. If this occurs, make a backup of any important data that is stored on the SSD, and then format it.
- During SSD recording, do not apply vibration to the instrument. Doing so may damage the SSD or may cause errors in SSD recording.
- During SSD recording, the  icon blinks in the center of the screen. While this icon is blinking, do not insert a USB storage device into the USB port for connecting peripheral devices. Doing so may cause the instrument to malfunction or may corrupt the data that is being recorded to the SSD.

French



ATTENTION

- Si l'alimentation est coupée pendant l'enregistrement du SSD, ce dernier risque d'être endommagé. Dans ce cas, effectuez une sauvegarde des données importantes stockées sur le SSD, puis formatez ce dernier.
- Pendant l'enregistrement du SSD, n'appliquez aucune vibration au DL950. Vous risqueriez d'endommager le SSD ou de créer des erreurs lors de l'enregistrement de ce dernier.
- Pendant l'enregistrement du SSD, l'icône clignote au centre de l'écran. Lorsque cette  icône clignote, ne connectez pas le support de stockage USB aux ports USB prévus à cet effet. Vous risqueriez de causer un dysfonctionnement du DL950 ou d'endommager les données en cours d'enregistrement sur le SSD.

Note

For information about how to save data, see chapter 19.

Chapter 4

Triggering

Main Control Areas Used in This Chapter

You can also use the touch panel.

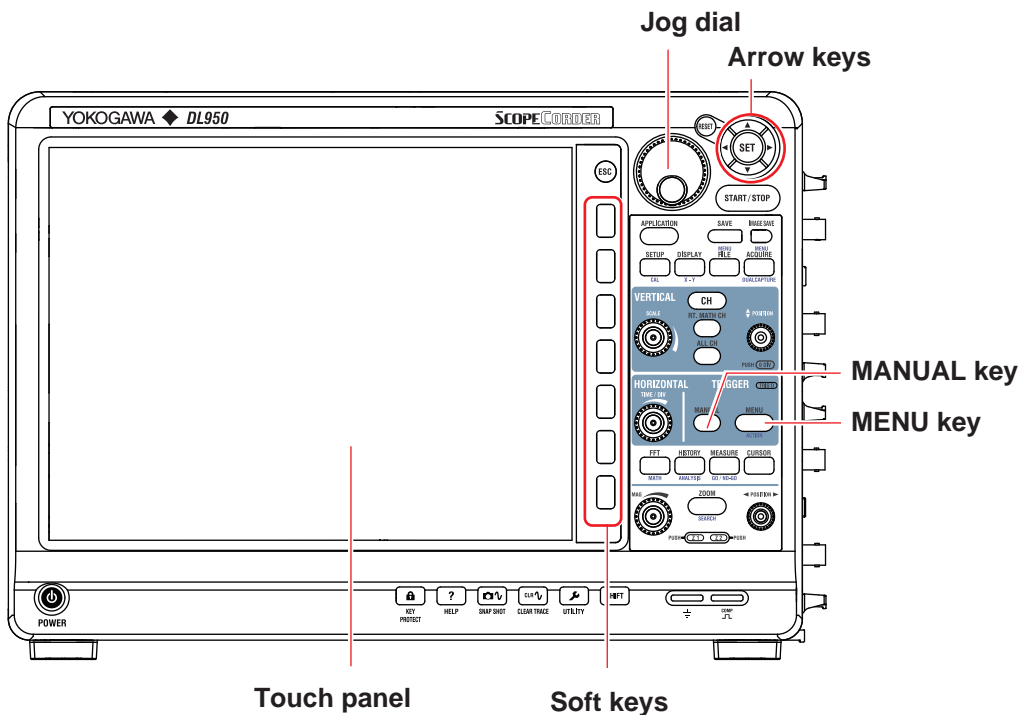

Operation Modes Applicable to the Sections in This Chapter

✓: Applicable, -: Not applicable

Section	Scope Mode	Recorder Mode
4.1 Setting the Trigger Mode	✓	-
4.2 Setting the Trigger Position, Trigger Delay, Trigger Delay, and Hold-off	✓	-
4.3 Triggering on an Edge Trigger (Simple) in Scope Mode	✓	-
4.4 Triggering on an Time Trigger (Simple) in Scope Mode	✓	-
4.5 Triggering on an External Trigger (Simple)	✓	-
4.6 Triggering on a Power Line Signal (Simple)	✓	-
4.7 Triggering on a Logic Trigger (Simple)	✓	-
4.8 Triggering on an A to B(N) Trigger (Enhanced)	✓	-
4.9 Triggering on an A Delay B Trigger (Enhanced)	✓	-
4.10 Triggering on an Edge On A Trigger (Enhanced)	✓	-
4.11 Triggering on an OR or AND Trigger (Enhanced) in Scope Mode	✓	-
4.12 Triggering on a Period Trigger (Enhanced)	✓	-
4.13 Triggering on a Pulse Width Trigger (Enhanced)	✓	-
4.14 Triggering on a Wave Window Trigger (Enhanced)	✓	-
4.15 Triggering on an Edge Trigger in Recorder Mode	-	✓
4.16 Triggering on a Time Trigger in Recorder Mode	-	✓
4.17 Triggering on an OR or AND Trigger in Recorder Mode	-	✓
4.18 Triggering the Instrument Manually (Manual Trigger)	✓	✓

* The settings may vary depending on the operation mode.

4.1 Setting the Trigger Mode

This section explains the following trigger settings:

Applicable in Scope Mode

- Trigger mode

► “Trigger Mode (Trigger Mode)” in the Features Guide

Trigger Mode Menu

1. On the waveform screen’s **MENU**, tap **TRIGGER > MENU**, or press **TRIG.MENU**. A trigger menu appears.
2. Tap **Trigger Mode**, or press the soft key. The trigger mode options are displayed.

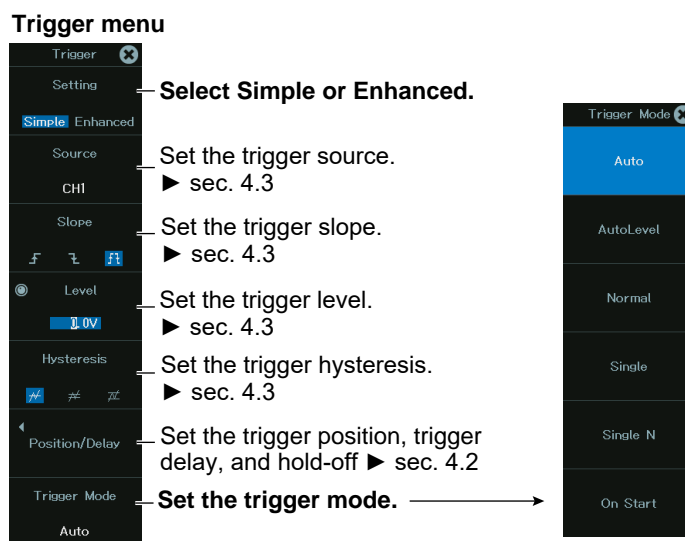

Setting the Trigger Mode (Trigger Mode)

3. Tap the trigger mode you want to use, or press the soft key.
 - Auto:** If the trigger conditions are met within a 50-ms timeout period, the instrument updates the displayed waveforms on each trigger occurrence. If not, this instrument automatically updates the displayed waveforms. If the time axis is set to a value that would cause the display to switch to roll mode, roll mode display will be enabled.
 - Auto Level:** If a trigger occurs before a timeout (which is approximately 1 second), the instrument updates the waveform in the same way that it does in Auto mode. If a trigger does not occur before a timeout, the instrument automatically changes the trigger level to the center value of the trigger source amplitude, triggers on that value, and updates the displayed waveform.
 - Normal:** The instrument updates the waveform display only when the trigger conditions are met.
 - Single:** When the trigger conditions are met, the instrument updates the displayed waveform once and stops signal acquisition. If the time axis is set to a range that causes the display to switch to roll mode, the roll mode display will be enabled. When the instrument triggers, it begins recording data. When data has been acquired up to the amount specified by the set record length, the waveform display stops.

- SingleN: The instrument acquires signals each time the trigger conditions are met until a specified number of signals have been acquired, stops acquisition, and displays all of the acquired signals. If no triggers occur, the display is not updated.
- On Start: Regardless of the trigger settings, when you press the START key, the instrument updates the displayed waveforms once and stops signal acquisition. If the time axis is set to a value that would cause the display to switch to roll mode, roll mode display will be enabled. When data has been acquired up to the amount specified by the set record length, the waveform display stops.

4.2 Setting the Trigger Position, Trigger Delay, and Hold-off

This section explains the following trigger settings:

Applicable in Scope Mode

- Trigger position
- Trigger delay
- Hold-off

► “Trigger Position (Position),” “Trigger Delay (Delay Time),” and “Trigger Hold-off (Hold Off)” in the Features Guide

POSITION/DELAY Menu

1. On the waveform screen’s **MENU**, tap **TRIGGER > MENU**, or press **TRIG.MENU**. A trigger menu appears.
2. Tap **Position/Delay**, or press the soft key. The following menu appears.

Trigger menu

Trigger menu

- Setting — Select Simple or Enhanced.
- Source — Set the trigger source. ► sec. 4.3
- Slope — Set the trigger slope. ► sec. 4.3
- Level — Set the trigger level. ► sec. 4.3
- Hysteresis — Set the trigger hysteresis. ► sec. 4.3
- Position/Delay — Set the position and delay. →
- Trigger Mode — Set the trigger mode. ► sec. 4.1

Position/Delay menu

- Position — Set the trigger position to a position of your choice.
- 10 — Set the trigger position to 10%.
- 50 — Set the trigger position to 50%.
- 90 — Set the trigger position to 90%.
- Hold Off — See “Setting the Hold-off Time.”
- Delay Time — See “Setting the Trigger Delay.”

Setting the Hold-off Time (Hold Off)

The trigger hold-off feature temporarily stops the detection of the next trigger once a trigger has occurred.

Setting the Trigger Delay (Delay Time)

The trigger delay is the delay from the trigger point until waveforms are displayed.

Note

You cannot specify a trigger delay when an external clock is being used as the time base.

4.3 Triggering on an Edge Trigger (Simple) in Scope Mode

This section explains the settings for triggering on the edges of an analog-signal trigger source in Scope mode: To use a logic signal for the trigger source, see section 4.7.

Applicable in Scope Mode

- Trigger source
- Trigger slope
- Trigger level
- Trigger hysteresis

► “Simple Trigger (Simple),” “Trigger Source (Source),” “Trigger Slope (Slope),” “Trigger Level (Level),” and “Trigger Hysteresis (Hysteresis)” in the Features Guide

Trigger Menu

1. On the waveform screen’s **MENU**, tap **TRIGGER > MENU**, or press **TRIG.MENU**. A trigger menu appears.

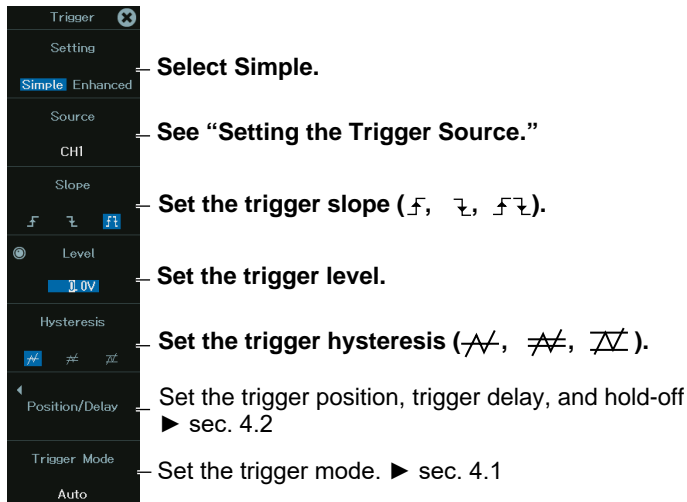

Note

If linear scaling is applied to the trigger source, set the trigger level using a linearly scaled value.

Setting the Trigger Source (Source)

2. Press the **Source** soft key. The following menu appears.

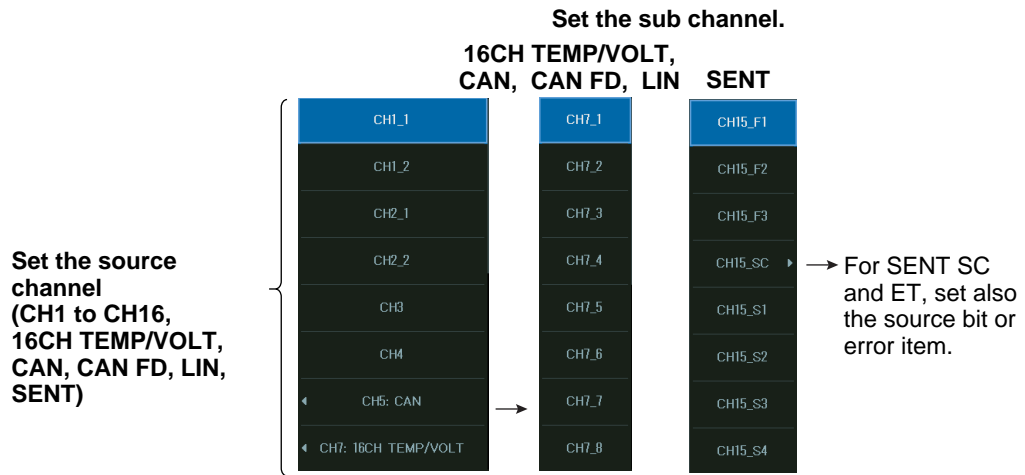

* The list displays channel numbers and labels. For 16CH TEMP/VOLT, CAN, CAN FD, LIN, and SENT, sub channel whose input (Input) is set to OFF cannot be selected.

4.4 Triggering on an Time Trigger (Simple) in Scope Mode

This section explains the settings that are used when triggering on a specific date and time in Scope mode.

Applicable in Scope Mode

- Trigger source
 - Date and time
 - Time interval
- ▶ “Simple Trigger (Simple)” and “Trigger Source (Source)” in the Features Guide

Trigger Menu

1. On the waveform screen’s **MENU**, tap **TRIGGER > MENU**, or press **TRIG.MENU**. A trigger menu appears.

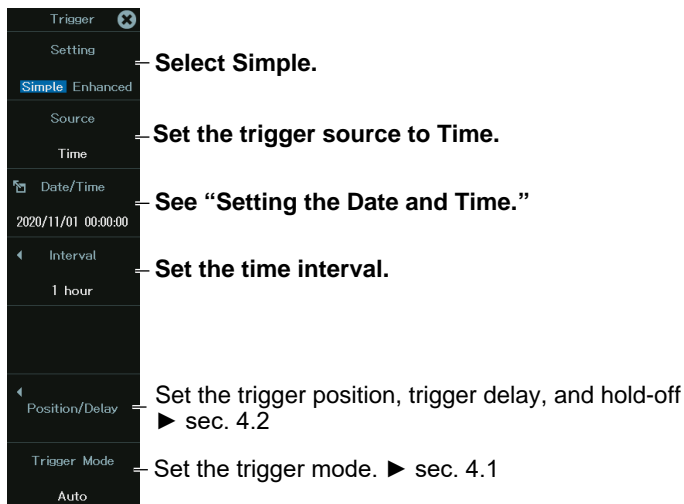

Setting the Date and Time (Date/Time Setting)

2. Press the **Date/Time** soft key. The following screen appears.

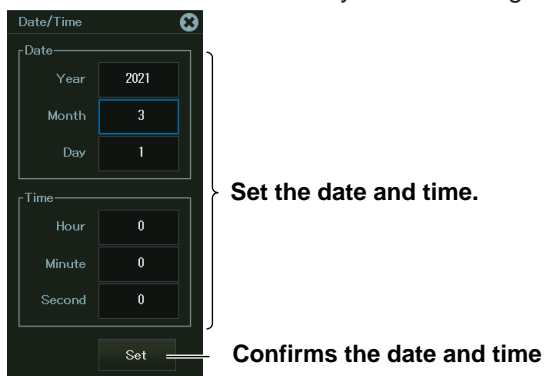

4.5 Triggering on an External Trigger (Simple)

This section explains the settings that are used when triggering on an external signal.

Applicable in Scope Mode

- Trigger source
 - Trigger slope
- “Simple Trigger (Simple)” and “Trigger Source (Source)” in the Features Guide

Trigger Menu

1. On the waveform screen’s **MENU**, tap **TRIGGER > MENU**, or press **TRIG.MENU**. A trigger menu appears.

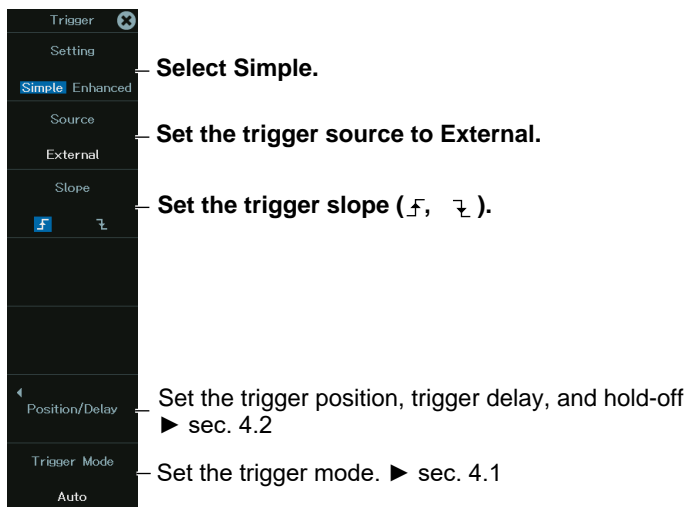

4.6 Triggering on a Power Line Signal (Simple)

This section explains the settings that are used when triggering on a power line signal.

Applicable in Scope Mode

- Trigger source
 - ▶ “Simple Trigger (Simple)” and “Trigger Source (Source)” in the Features Guide

Trigger Menu

1. On the waveform screen’s **MENU**, tap **TRIGGER > MENU**, or press **TRIG.MENU**. A trigger menu appears.

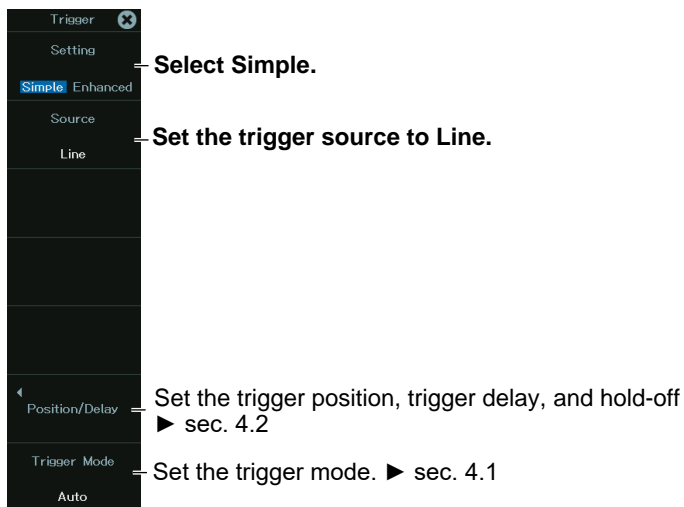

4.7 Triggering on a Logic Trigger (Simple)

This section explains the following settings for triggering on the edges of a logic-signal trigger source:

Applicable in Scope Mode

- Trigger source
- Source bit
- Trigger slope

► “Simple Trigger (Simple)” and “Trigger Source (Source)” in the Features Guide

Trigger Menu

1. On the waveform screen’s **MENU**, tap **TRIGGER > MENU**, or press **TRIG.MENU**. A trigger menu appears.

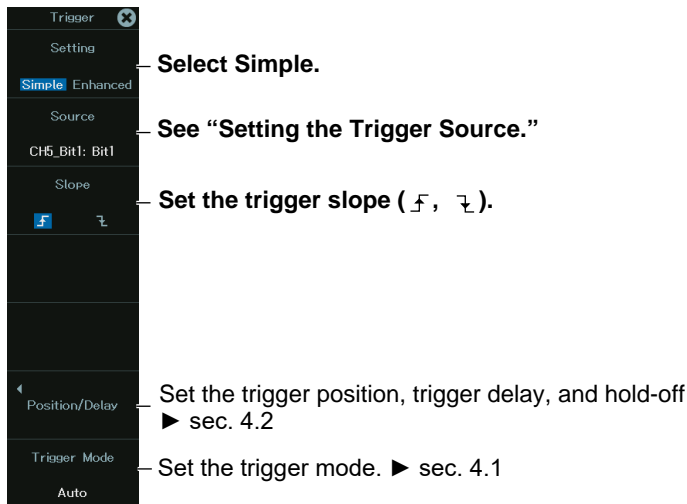

Setting the Trigger Source (Source)

2. Press the **Source** soft key. The following menu appears.

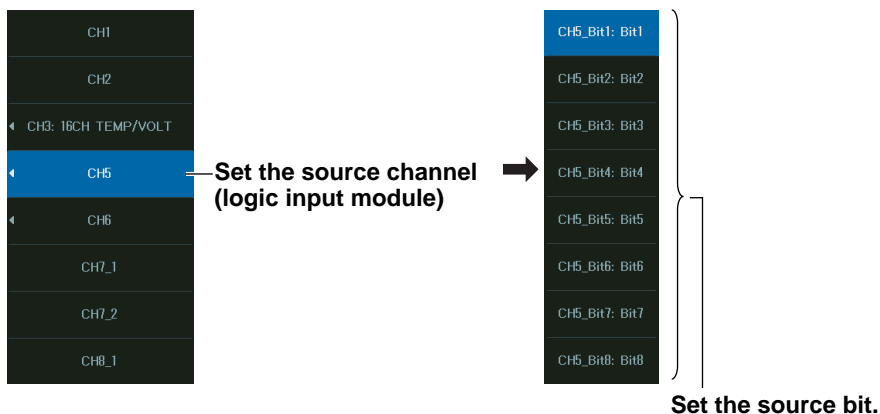

4.8 Triggering on an A to B(N) Trigger (Enhanced)

This section explains the following settings for triggering on an A to B(N) trigger:

Applicable in Scope Mode

- Trigger source
- State condition
- State condition achievement condition
- Number of times state condition B must be met
- Trigger conditions (trigger level, hysteresis)

► [“A to B\(N\) Trigger \(Enhanced\)” in the Features Guide](#)

Trigger Menu

1. On the waveform screen’s **MENU**, tap **TRIGGER > MENU**, or press **TRIG.MENU**. A trigger menu appears.

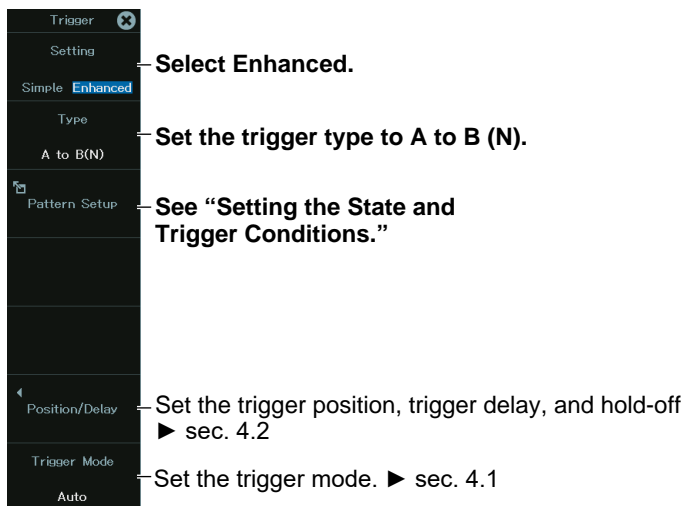

Setting the State and Trigger Conditions (Pattern Setup)

2. Tap **Pattern Setup**, or press the soft key. The following menu appears.

Set the state condition (H, L, or X (do not use as a trigger source)).

Set the trigger level.

Set the hysteresis (\overline{A} , \overline{A} , \overline{A}).

	A State	B State	Level	Hys
CH1	H	H	0.0V	\overline{A}
CH2	X	X	0.0V	\overline{A}
CH3: 16CH TEMP/VOL				
CH4				
CH5				
CH6				
CH7_1		X	0.0V	\overline{A}
CH7_2		X	0.0V	\overline{A}
CH8_1		X	0.0V	\overline{A}
CH8_2		X	0.0V	\overline{A}

A Condition

B Condition

Delay Time
 0.00us

Set the state condition achievement conditions (Enter, Exit).

Set the number of times state condition B must be met.
 On a module with logic inputs or sub channels, expand the menu, and set each bit or sub channel.

Note

If linear scaling is applied to the trigger source, set the trigger level using a linearly scaled value.

4.9 Triggering on an A Delay B Trigger (Enhanced)

This section explains the following settings for triggering on an A Delay B trigger:

Applicable in Scope Mode

- Trigger source
- State condition
- State condition achievement condition
- Delay time
- Trigger conditions (trigger level, hysteresis)

► [“A Delay B Trigger \(Enhanced\)” in the Features Guide](#)

Trigger Menu

1. On the waveform screen’s **MENU**, tap **TRIGGER > MENU**, or press **TRIG.MENU**. A trigger menu appears.

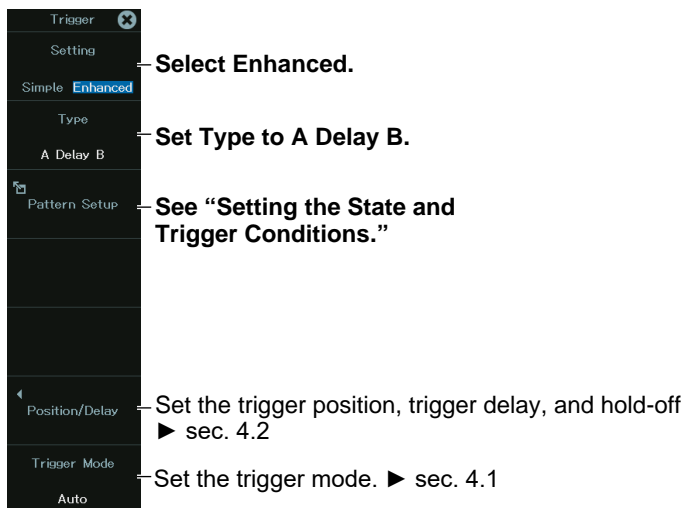

Setting the State and Trigger Conditions (Pattern Setup)

2. Tap **Pattern Setup**, or press the soft key. The following menu appears.

Set the state condition (H, L, or X (do not use as a trigger source)).

Set the trigger level.

Set the hysteresis (\overline{A} , \overline{B} , \overline{A}).

	A State	B State	Level	Hys
CH1	H	H	1.0V	\neq
CH2	H	L	0.0V	\neq
CH3: 16CH TEMP/VOLT				
CH4				
CH5				
CH6				
CH7_1	X	X	0.0V	\neq
CH7_2	X	X	0.0V	\neq
CH8_1	X	X	0.0V	\neq
CH8_2	X	X	0.0V	\neq

Set the state condition achievement conditions (Enter, Exit)

Set the delay time.

On a module with logic inputs or sub channels, expand the menu, and set each bit or sub channel.

Note

If linear scaling is applied to the trigger source, set the trigger level using a linearly scaled value.

4.10 Triggering on an Edge On A Trigger (Enhanced)

This section explains the following settings for triggering on an Edge On A trigger:

Applicable in Scope Mode

- Trigger source
- State condition
- State condition achievement condition
- Edge detection condition
- Trigger conditions (trigger level, hysteresis)

► [“Edge On A Trigger \(Enhanced\)” in the Features Guide](#)

Trigger Menu

1. On the waveform screen’s **MENU**, tap **TRIGGER > MENU**, or press **TRIG.MENU**. A trigger menu appears.

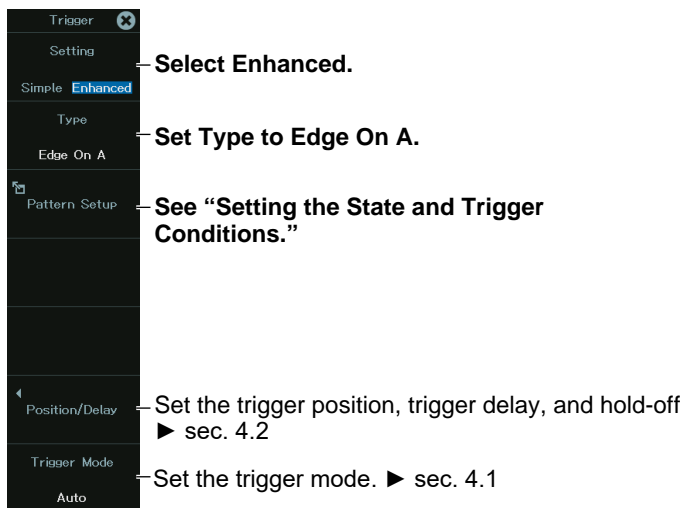

Setting the State and Trigger Conditions (Pattern Setup)

2. Tap **Pattern Setup**, or press the soft key. The following menu appears.

Set the state condition (H, L, or X (do not use as a trigger source)).

Set the edge detection condition (F, \bar{F} , -).

Set the trigger level.

Set the hysteresis ($\bar{\Delta}$, Δ , $\bar{\Delta}$).

Channel	A State	Edge	Level	Hys	Condition
CH1	H	-	0.0V	\neq	True
CH2	X	F	0.0V	\neq	
CH3: 16CH TEMP/VOLT					
CH4					
CH5					
CH6					
CH7	X	F	0uSTR	\neq	
CH8	X	-	0uSTR	\neq	
CH9	X	-	0.00V	\neq	
CH10	X	-	0.00V	\neq	

On a module with logic inputs or sub channels, expand the menu, and set each bit or sub channel.

Note

If linear scaling is applied to the trigger source, set the trigger level using a linearly scaled value.

4.11 Triggering on an OR or AND Trigger (Enhanced) in Scope Mode

This section explains the following settings for triggering on an OR or AND trigger:

Applicable in Scope Mode

- Trigger source
- Edge detection condition (OR trigger)
- Achievement condition (AND trigger)
- Trigger conditions (trigger level, hysteresis)

► “OR Trigger (Enhanced)” and “AND Trigger (Enhanced)” in the Features Guide

Trigger Menu

1. On the waveform screen’s **MENU**, tap **TRIGGER > MENU**, or press **TRIG.MENU**. A trigger menu appears.

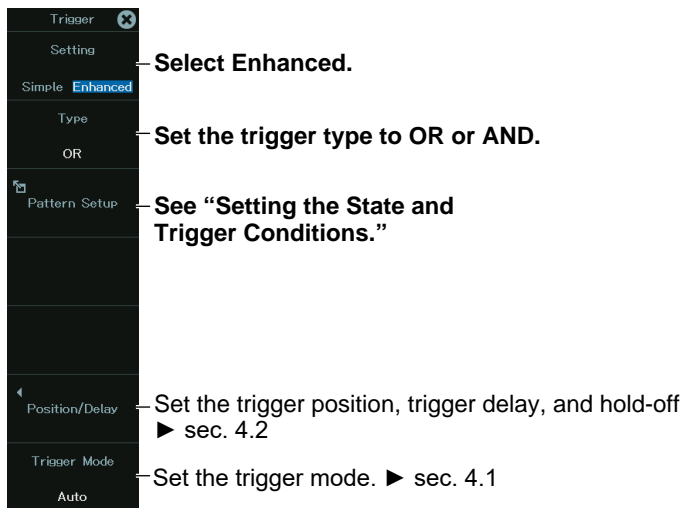

Setting the State and Trigger Conditions (Pattern Setup)

2. Tap **Pattern Setup**, or press the soft key. The following menu appears.

OR trigger

Set the edge detection condition (\uparrow , \downarrow , IN, OUT, —).

Set the trigger level.

Set the level width (when the edge detection condition is set to IN or OUT).

Set the hysteresis. ($\overline{\Delta}$, $\overline{\neq}$, $\overline{\Delta}$)

On a module with logic inputs or sub channels, expand the menu, and set each bit or sub channel.

	Edge	Level	Width	Hys
CH1_1	\uparrow	2.0V	5.0V	$\overline{\neq}$
CH1_2	IN	0.0V	5.0V	$\overline{\neq}$
CH2_1	\downarrow	3.0V	5.0V	$\overline{\neq}$
CH2_2	OUT	0.0V	5.0V	$\overline{\neq}$
CH3	—	0.0V	5.0V	$\overline{\neq}$
CH4	—	0.0V	5.0V	$\overline{\neq}$
CH5: CAN	\uparrow			
CH6: LIN	\uparrow			
CH7: 16CH TEMP/VOLT	\uparrow			
CH8				

AND Trigger

Set the achievement condition (H, L, IN, OUT, —).

Set the trigger level.

Set the level width (when the edge detection condition is set to IN or OUT).

Set the hysteresis. ($\overline{\Delta}$, $\overline{\neq}$, $\overline{\Delta}$)

On a module with logic inputs or sub channels, expand the menu, and set each bit or sub channel.

	Condition	Level	Width	Hys
CH1_1	H	2.0V	5.0V	$\overline{\neq}$
CH1_2	L	0.0V	5.0V	$\overline{\neq}$
CH2_1	IN	3.0V	5.0V	$\overline{\neq}$
CH2_2	OUT	0.0V	5.0V	$\overline{\neq}$
CH3	—	0.0V	5.0V	$\overline{\neq}$
CH4	—	0.0V	5.0V	$\overline{\neq}$
CH5: CAN	\uparrow			
CH6: LIN	\uparrow			
CH7: 16CH TEMP/VOLT	\uparrow			
CH8				

Note

If linear scaling is applied to the trigger source, set the trigger level using a linearly scaled value.

4.12 Triggering on a Period Trigger (Enhanced)

This section explains the following settings for triggering on a period trigger:

Applicable in Scope Mode

- Trigger source
- State condition
- Determination mode
- Reference time
- Trigger conditions (trigger level, hysteresis)

► [“Period Trigger \(Enhanced\)” in the Features Guide](#)

Trigger Menu

1. On the waveform screen’s **MENU**, tap **TRIGGER > MENU**, or press **TRIG.MENU**. A trigger menu appears.

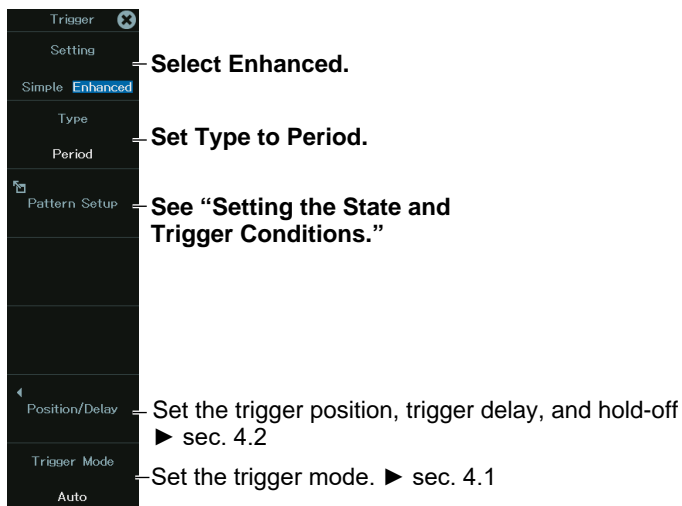

Setting the State and Trigger Conditions (Pattern Setup)

2. Tap **Pattern Setup**, or press the soft key. The following menu appears.

Set the state condition (H, L, or X (do not use as a trigger source)).

Set the trigger level.

Set the hysteresis (\overline{A} , $\overline{A\overline{B}}$, $\overline{A\overline{B}}$).

Period	B State	Level	Hys
CH1	H	0.0V	\overline{A}
CH2	X	0.0V	\overline{A}
CH3: 16CH TEMP/VOLT			
CH4			
CH5			
CH6			
CH7	X	0uSTR	\overline{A}
CH8	X	0uSTR	\overline{A}
CH9	X	0.00V	\overline{A}
CH10	X	0.00V	\overline{A}

Mode: T < Time

Time: 0.02us

On a module with logic inputs or sub channels, expand the menu, and set each bit or sub channel.

* Set T1 and T2 when the determination mode is T1 < T < T2 or T <T1, T2 < T.
Set Time when the determination mode is T < Time or T >Time.

Note

If linear scaling is applied to the trigger source, set the trigger level using a linearly scaled value.

Setting the Determination Mode (Mode)

Set what kind of relationship must be established between period T and the specified reference times (Time or T1 and T2) for the instrument to trigger.

T < Time	Period T must be shorter than the reference time (Time).
T > Time	Period T must be longer than the reference time (Time).
T1 < T < T2	Period T must be longer than reference time T1 and shorter than reference time T2.
T < T1, T2 < T	Period T must be shorter than reference time T1 or longer than reference time T2.

4.13 Triggering on a Pulse Width Trigger (Enhanced)

This section explains the following settings for triggering on a pulse width trigger:

- Trigger source
- State condition
- Determination mode
- Reference time
- Trigger conditions (trigger level, hysteresis)

► [“Pulse Width Trigger \(Enhanced\)” in the Features Guide](#)

Trigger Menu

1. On the waveform screen’s **MENU**, tap **TRIGGER > MENU**, or press **TRIG.MENU**. A trigger menu appears.

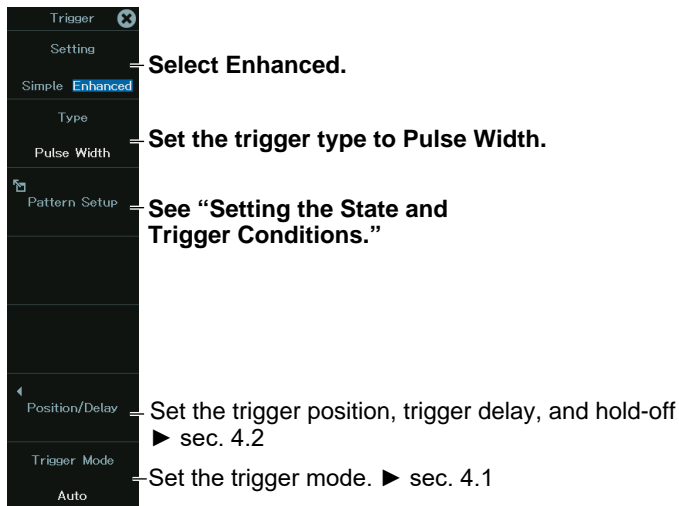

Setting the State and Trigger Conditions (Pattern Setup)

2. Tap **Pattern Setup**, or press the soft key. The following menu appears.

Set the state condition (H, L, or X (do not use as a trigger source)).

Set the trigger level.

Set the hysteresis (\overline{A} , $\overline{A\overline{B}}$, $\overline{A\overline{B}}$).

	B State	Level	Hys
CH1	H	0.0V	\overline{A}
CH2	X	0.0V	\overline{A}
CH3: 16CH TEMP/VOLT			
CH4			
CH5			
CH6			
CH7	X	0uSTR	\overline{A}
CH8	X	0uSTR	\overline{A}
CH9	X	0.00V	\overline{A}
CH10	X	0.00V	\overline{A}

Mode: B < Time

Time: 0.02us

On a module with logic inputs or sub channels, expand the menu, and set each bit or sub channel.

* Set T1 and T2 when the determination mode is B Between.
Set Time when the determination mode is B < Time, B > Time, or B TimeOut.

Note

If linear scaling is applied to the trigger source, set the trigger level using a linearly scaled value.

Setting the Determination Mode (Mode)

Set what kind of relationship must be established between the state condition B achievement time and the specified reference times (Time or T1 and T2) for the instrument to trigger.

B < Time	The instrument triggers when the achievement time is shorter than the reference time (Time), and the state condition changes from being met to not being met.
B > Time	The instrument triggers when the achievement time is longer than the reference time (Time), and the state condition changes from being met to not being met.
B TimeOut	The instrument triggers when the achievement time is longer than the reference time (Time).
B Between	The instrument triggers when the achievement time is longer than reference time T1 and shorter than reference time T2, and the state condition changes from being met to not being met.

4.14 Triggering on a Wave Window Trigger (Enhanced)

This section explains the following settings for triggering on a wave window trigger:

- Source channels
- Tolerance width, cycle frequency, and reference cycle
- Synchronization channel
- Level for detecting the start and end points
- Hysteresis

► [“Wave Window Trigger \(Enhanced\)” in the Features Guide](#)

Trigger Menu

1. On the waveform screen’s **MENU**, tap **TRIGGER > MENU**, or press **TRIG.MENU**. A trigger menu appears.

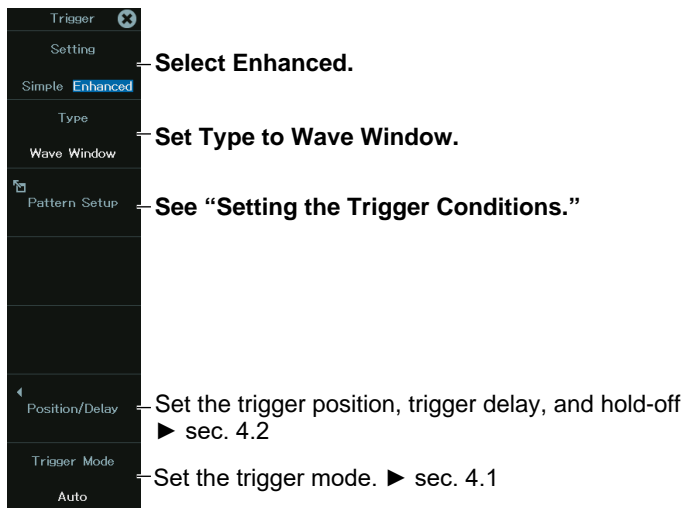

Setting the Trigger Conditions (Pattern Setup)

2. Tap **Pattern Setup**, or press the soft key. The following menu appears.

Set the source channel (ON, OFF).
Set the tolerance width.

Wave Window	Condition	Width	
CH1	ON	0.5V	
CH2	ON	0.5V	
CH3: 16CH TEMP/VOLT			
CH4			
CH5			
CH6			
CH7	OFF	1uSTR	
CH8	OFF	1uSTR	
CH9	OFF	0.05V	
CH10	OFF	0.05V	

Cycle Frequency
50Hz — Set the cycle frequency.

Reference Cycle
1 2 4 — Set the reference cycle.

Sync. Ch
CH2 — Set the synchronization channel (Auto, CH1 to CH16).

Level
0.0V — Set the level for detecting the start and end points.*+

Hysteresis
≠ — Set the hysteresis (\overline{A} , \overline{A} , $\overline{\overline{A}}$).*

* Not required when the synchronization channel is Auto

4.15 Triggering on an Edge Trigger in Recorder Mode

This section explains the settings that are used when triggering on a specific edge in Recorder mode.

Applicable in Recorder Mode

- Trigger source
- Trigger slope
- Trigger level
- Trigger hysteresis
- Pre-trigger

► “Trigger Source (Source),” “Trigger Slope (Slope),” “Trigger Level (Level),” “Trigger Hysteresis (Hysteresis),” “Pre-Trigger (Pre Trigger)” and “Edge Trigger(Edge)” in the Features Guide

Trigger Menu

1. On the waveform screen’s **MENU**, tap **TRIGGER > MENU**, or press **TRIG.MENU**. A trigger menu appears.

The Trigger menu appears only when Acquisition Condition in the waveform acquisition conditions is set to Capture On Trigger.

For input other than logic

Trigger	✕
Type	— Select Edge.
Edge	— Select Edge.
Source	— See “Setting the Trigger Source.”
CH1_1	
Slope	— Set the trigger slope. (f, r, fr)
Level	— Set the trigger level.
1.0V	
Hysteresis	— Set the trigger hysteresis. (A, A, A)
Pri Trigger	— Set the pre-trigger.
10.0%	

For logic input

Trigger	✕
Type	— Select Edge.
Edge	— Select Edge.
Source	— See “Setting the Trigger Source.”
CH3_Bit2: Bit2	
Slope	— Set the trigger slope (f, r).
Pri Trigger	— Set the pre-trigger.
10.0%	

Note

If linear scaling is applied to the trigger source, set the trigger level using a linearly scaled value.

Setting the Trigger Source (Source)

2. Press the **Source** soft key. The following menu appears.

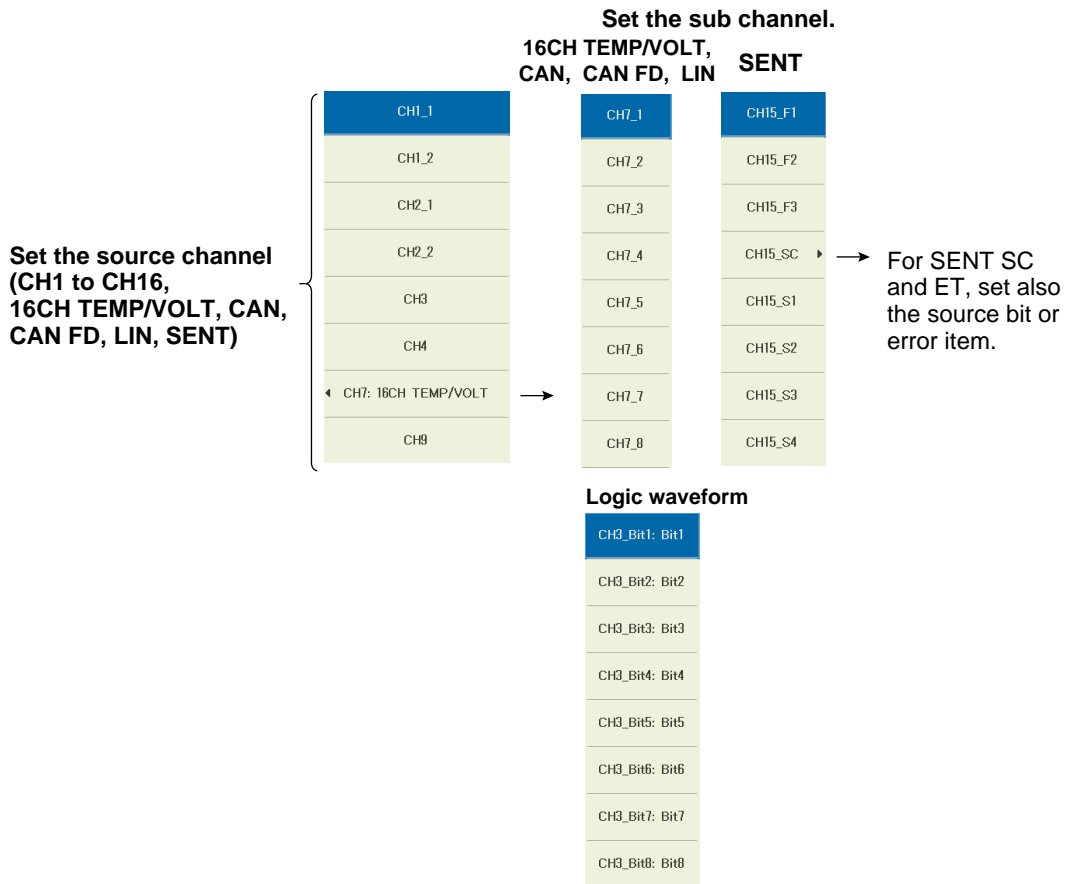

* The list displays channel numbers and display labels. For 16CH TEMP/VOLT, CAN, CAN FD, LIN, and SENT, sub channel whose input (Input) is set to OFF cannot be selected.

4.16 Triggering on a Time Trigger in Recorder Mode

This section explains the settings that are used when triggering on a specific date and time in Recorder mode.

Applicable in Recorder Mode

- Trigger source
- Date and time
- Pre-trigger

► “Pre-Trigger (Pre Trigger)” and “Time Trigger (Time)” in the Features Guide

Trigger Menu

1. On the waveform screen's **MENU**, tap **TRIGGER > MENU**, or press **TRIG.MENU**. A trigger menu appears.

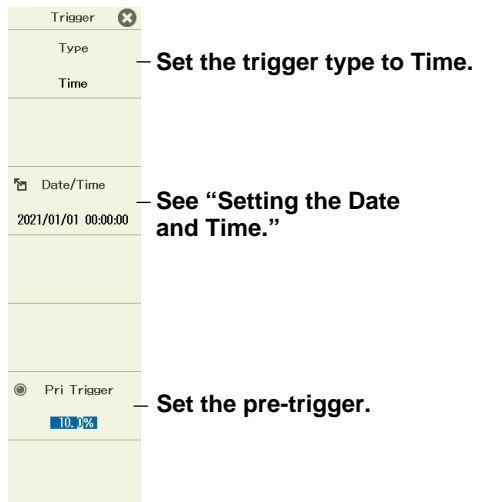

Setting the Date and Time (Date/Time Setting)

2. Press the **Date/Time Setting** soft key. The following screen appears.

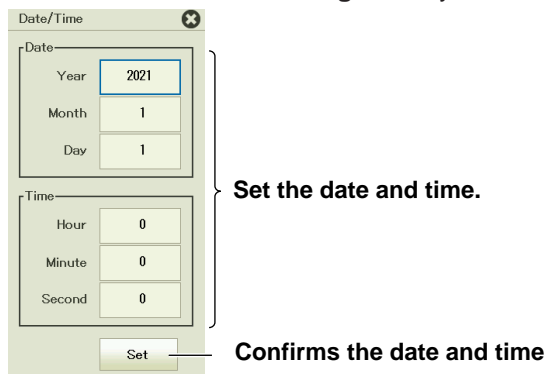

4.17 Triggering on an OR or AND Trigger in Recorder Mode

This section explains the following settings for triggering on an OR or AND trigger in Recorder mode:

Applicable in Recorder Mode

- Trigger source
- Edge detection condition (OR trigger)
- Achievement condition (AND trigger)
- Trigger conditions
- Pre-trigger

► “Pre-Trigger (Pre Trigger),” “OR Trigger (Enhanced),” and “AND Trigger (Enhanced)” in the Features Guide

Trigger Menu

1. On the waveform screen’s **MENU**, tap **TRIGGER > MENU**, or press **TRIG.MENU**. A trigger menu appears.

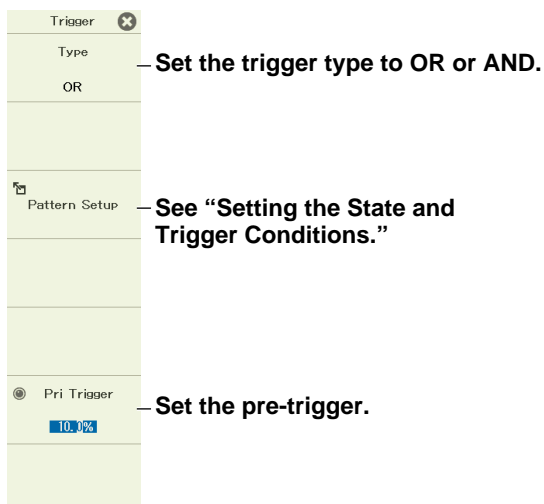

Setting the State and Trigger Conditions (Pattern Setup)

2. Tap **Setup**, or press the soft key. The following menu appears.

OR trigger

Set the edge detection condition (F, \bar{F} , IN, OUT, -).

Set the trigger level.

Set the level width (when the edge detection condition is set to IN or OUT).

Set the hysteresis. (~~AV~~, ~~AV~~, ~~AV~~)

	Edge	Level	Width	Hys
CH1	F	0.0V	5.0V	AV
CH2	\bar{F}	0.0V	5.0V	AV
CH3: 16CH TEMP/VOLT	+			
CH4				
CH5	+			
CH6	+			
CH7	IN	0.0Hz	100.0Hz	AV
CH8	OUT	0.0Hz	100.0Hz	AV
CH9	-	0.00V	0.50V	AV
CH10	-	0.00V	0.50V	AV

On a module with logic inputs or sub channels, expand the menu, and set each bit or sub channel.

AND Trigger

Set the achievement condition (H, L, IN, OUT, —).

Set the trigger level.

Set the level width (when the edge detection condition is set to IN or OUT).

Set the hysteresis. (~~AV~~, ~~AV~~, ~~AV~~)

	Condition	Level	Width	Hys
CH1	IN	0.0V	5.0V	AV
CH2	OUT	0.0V	5.0V	AV
CH3: 16CH TEMP/VOLT	+			
CH4				
CH5	+			
CH6	+			
CH7	H	0.0Hz	100.0Hz	AV
CH8	L	0.0Hz	100.0Hz	AV
CH9	-	0.00V	0.50V	AV
CH10	-	0.00V	0.50V	AV

On a module with logic inputs or sub channels, expand the menu, and set each bit or sub channel.

Note

If linear scaling is applied to the trigger source, set the trigger level using a linearly scaled value.

4.18 Triggering the Instrument Manually (Manual Trigger)

Items Common to Scope Mode and Recorder Mode

▶ [“Trigger Types \(Type\)” in the Features Guide](#)

1. On the waveform screen’s **MENU**, tap **TRIGGER > MANUAL**, or press **MANUAL**.
The instrument triggers, and waveform acquisition starts.

Chapter 5

Display

Main Control Areas Used in This Chapter

You can also use the touch panel.

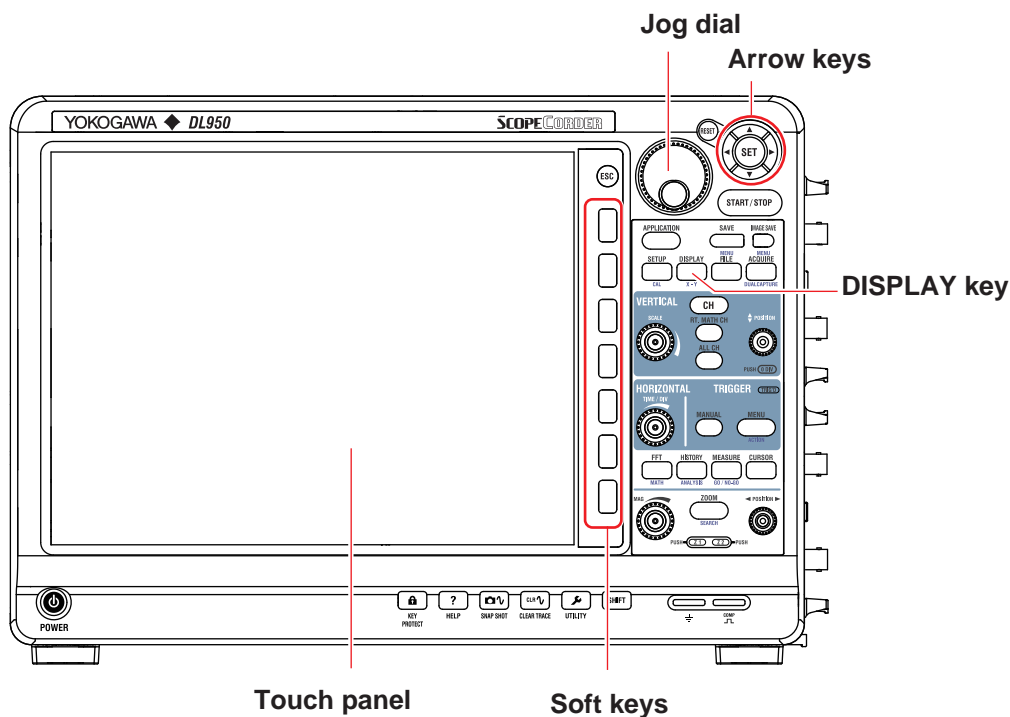

Operation Modes Applicable to the Sections in This Chapter

✓: Applicable, -: Not applicable

Section	Scope Mode	Recorder Mode
5.1 Setting Display Groups and Display Format	✓	✓
5.2 Setting the Waveform Arrangement, Color, and Grouping	✓	✓
5.3 Setting the Grid and Interpolation Method	✓	✓
5.4 Configuring the Detailed Display Settings	✓	✓
5.5 Using the Accumulate Feature (Scope mode)	✓	✓
5.6 Using the Snapshot and Clear Trace Features	-	✓

* The settings may vary depending on the operation mode.

5.1 Setting Display Groups and Display Format

This section explains the following settings for displaying waveforms:

Items Common to Scope Mode and Recorder Mode

- Display group, display format (number of divided screens)
 - ▶ “Group Selection (Select Group)” and “Display Format (Format)” in the Features Guide

Display Menu

1. On the waveform screen’s **MENU** tap **DISPLAY > DISPLAY**, or press **DISPLAY**. The Display menu appears.

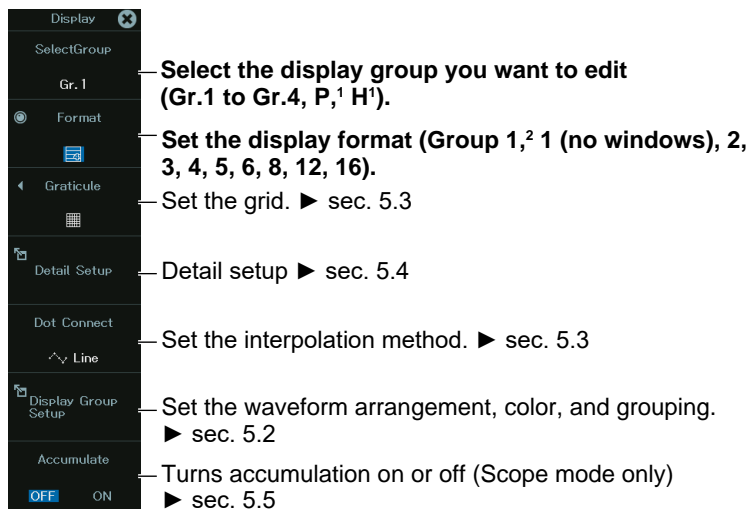

- 1 Selectable on models with the power math option (/G5)
- 2 The Group 1 option appears when display groups 2 to 4, P, or H is selected.

Changing the Display Group Shown on the Screen

2. You can also tap Gr1 to Gr4, GrP (power analysis), or GrH (harmonic analysis) at the bottom of the screen to change the display group.



Tap the display group to show on the screen.
(GrP and GrH are available when power analysis or harmonic analysis is not set to OFF.)

5.2 Setting the Waveform Arrangement, Color, and Grouping

This section explains the following settings for displaying waveforms:

Items Common to Scope Mode and Recorder Mode

- Waveform arrangement, color, and grouping
 - ▶ “Display Group Setup (Display Group Setup)” in the Features Guide

Display Menu

- On the waveform screen’s **MENU** tap **DISPLAY > DISPLAY**, or press **DISPLAY**. The Display menu appears.

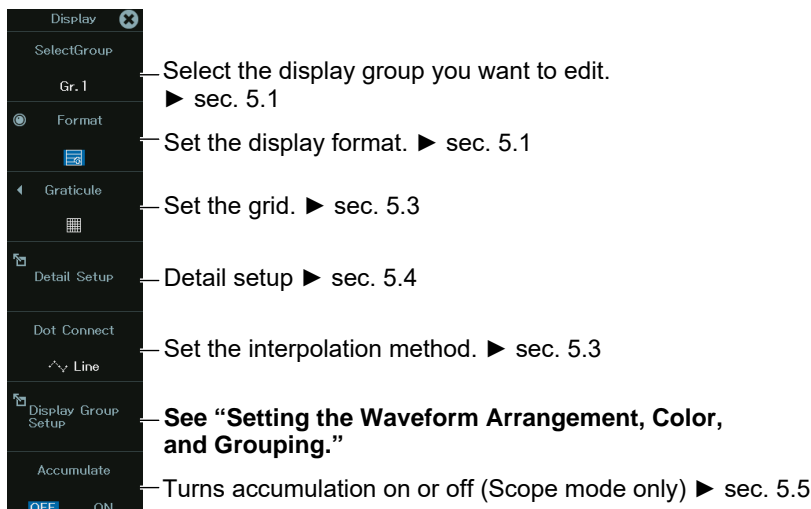

Setting the Waveform Arrangement, Color, and Grouping (Display Group Setup)

- Tap **Display Group Setup**, or press the soft key. The following screen appears.

Set the mapping mode (Auto, User).

The screenshot shows the 'Display Group #1' setup screen. It includes a 'Mapping Mode' selector (Auto/User), a 'Mapping list' table, and a 'Select Display Group' sidebar.

#	CH		#	CH		#	CH	
1	FFT0	■	2	FFT0	■	3	FFT0	■
4	FFT0	■	5	FFT0	■	6	FFT0	■
7	FFT0	■	8	FFT0	■	9	FFT0	■
10	FFT0	■	11	FFT0	■	12	FFT0	■
13	FFT0	■	14	FFT0	■	15	FFT0	■
16	FFT0	■	17	FFT0	■	18	FFT0	■
19	FFT0	■	20	FFT0	■	21	FFT0	■
22	FFT0	■	23	FFT0	■	24	FFT0	■
25	FFT0	■	26	FFT0	■	27	FFT0	■
28	FFT0	■	29	FFT0	■	30	FFT0	■
31	FFT0	■	32	FFT0	■	33	FFT0	■

Annotations:

- Set the display colors.** (Points to the color swatches in the mapping list)
- Set the waveforms that you want to map.** (Points to the channel names in the mapping list)
- When the mapping method is set to User, set how to map each channel’s waveform to the divided screens (1 to 16).** (Points to the mapping list)
- Select the display group.** Group Analysis is for power analysis and harmonic groups (/G05 option). (Points to the 'Group #1' selection in the sidebar)
- Clears all the settings of the specified group** (Points to 'Group #1 All Clear' in the sidebar)
- Automatically reassigns just the waveforms whose displays are turned on** (Points to 'Auto Grouping' in the sidebar)

5.3 Setting the Grid and Interpolation Method

This section explains the waveform information and preference settings for displaying waveforms.

Items Common to Scope Mode and Recorder Mode

- Grid
- Interpolation method
 - ▶ [“Grid \(Graticule\)” and “Interpolation Method \(Dot Connect\)” in the Features Guide](#)

Display Menu

1. On the waveform screen’s **MENU** tap **DISPLAY > DISPLAY**, or press **DISPLAY**. The Display menu appears.

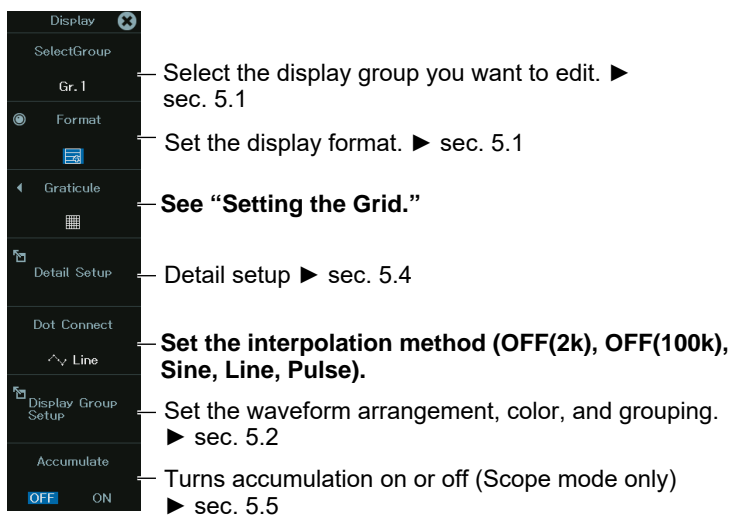

Setting the Grid (Graticule)

2. Tap **Graticule**, or tap the soft key. The following window appears.

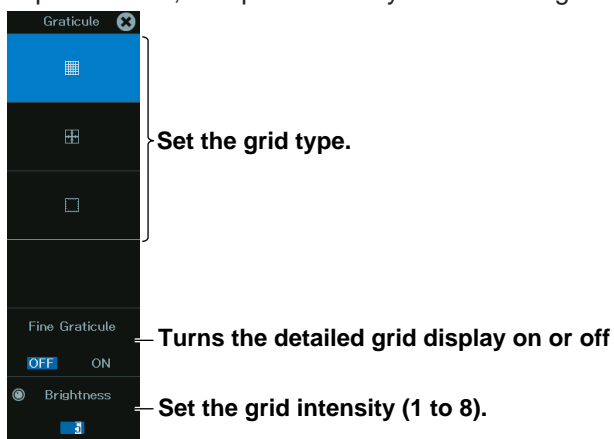

Interpolation method

You can select the interpolation method from the following:

- OFF(2k): Interpolation is not performed. If outside the interpolation area and the display record length exceeds 2 kpoint, the data is decimated down to 2 kpoint and displayed. If the display record length is less than or equal to 2 kpoint, all the points are displayed.
- OFF(100k): Interpolation is not performed. If outside the interpolation area and 100 kpoint is exceeded, the data is decimated down to 100 kpoint and displayed. If the display record length is less than or equal to 100 kpoint, all the points are displayed.
- Sine: Sampling data is interpolated with a sine curve.
- Line: Sampling data is interpolated linearly.
- Pulse: Sampling data is interpolated stepwise.

5.4 Configuring the Detailed Display Settings

This section explains detailed display settings such as scale display and font size.

Items Common to Scope Mode and Recorder Mode

- Scale value's display item
- Scale font size
- Horizontal axis display mode
- Turning the extra window on and off
- Number of displayed digits for analysis results (1 to 20)
- Font size for displaying analysis results
- Menu font size
- Screen background color
- Turning the trace label display on and off
- Turning the level indicator on and off
- Channel information
- Channel information display range
- Turning the manual event display on and off

► [“Detail Setup \(Detail Setup\)” in the Features Guide](#)

Display Menu

1. On the waveform screen's **MENU** tap **DISPLAY > DISPLAY**, or press **DISPLAY**. The Display menu appears.

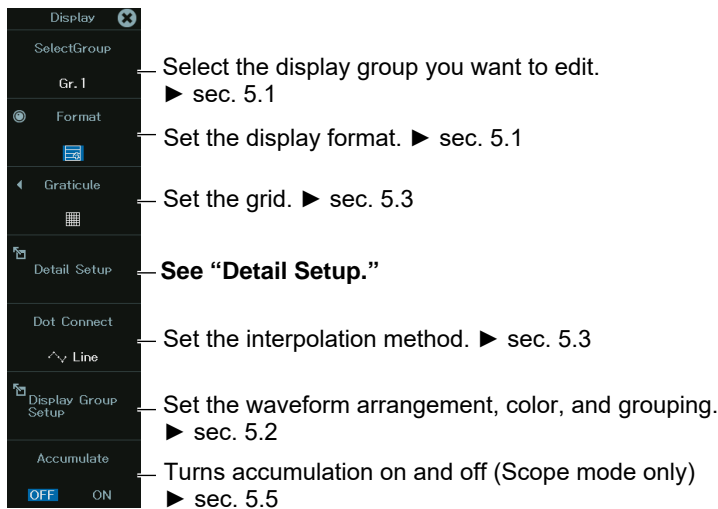

Detail Setup (Detail Setup)

2. Tap **Detail Setup**, or press the soft key. The following screen appears.

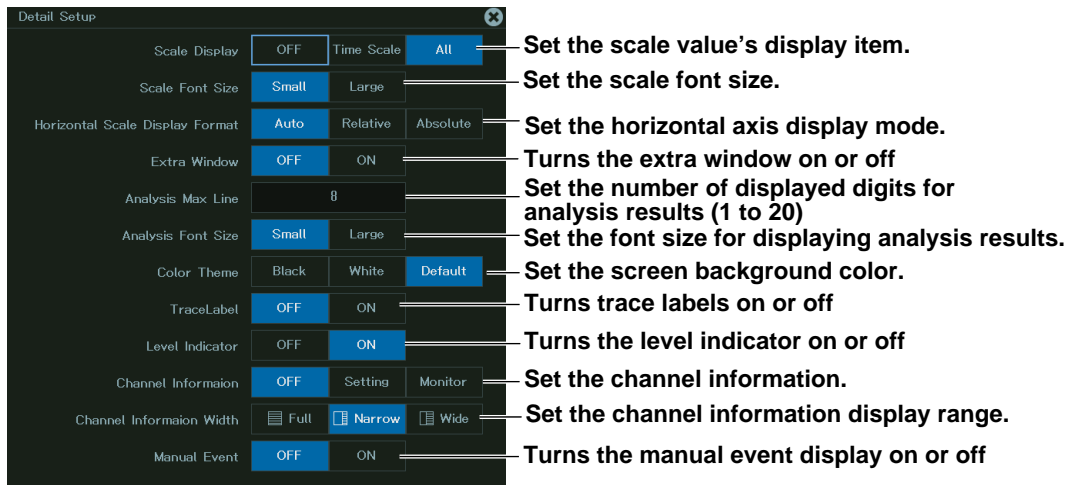

Scale Value's Display Item

Select from the following items:

- OFF: Scale values are not displayed.
- All : All scale values are displayed.
- Time Scale : Only time scale values are displayed.

Horizontal Axis Display Mode

Select from the following items:

- Relative time: Relative time from the start of measurement
- Absolute time: Absolute time of measurement (not selectable when the measurement time is 1 second or less)
- Auto: Automatically set according to the horizontal scale (TIME DIV) at the time of measurement

Channel Information

Set the contents to display as channel information.

- OFF: Not displayed
- Setting: Setup parameters
- Monitor: Measured values

Channel Information Display Range

Set the channel information display range.

- Full: Channel information is displayed in full screen.
- Narrow: Channel information is displayed with the same width as the setup menu.
- Wide: Channel information is displayed with the same width as the setup menu in two columns.

5.4 Configuring the Detailed Display Settings

Channel Information Display Method

With the setup menu not shown on the screen, tap the channel information icon at the lower right of the screen.

The icon varies depending on the channel information display range setting.

When the setup menu is not displayed, you can press ESC to switch between setup information display, measured value display, and hidden.

When the channel information display is on, the icon background is displayed in blue.

Waveform display
Setup information and measurement

Measurement display (monitor)

Setup information display

Set the channel information display range.

Channel information icon

- When the channel information display range is set to Full
- When the channel information display range is set to Wide
- When the channel information display range is set to Narrow

5.5 Using the Accumulate Feature (Scope mode)

This section explains the following accumulation settings:

Applicable in Scope Mode

- Turning accumulation on and off
- Number of times to accumulate waveforms

► “Accumulation (Accumulate)” in the Features Guide

Display Menu

1. On the waveform screen's **MENU** tap **DISPLAY > DISPLAY**, or press **DISPLAY**. The Display menu appears.

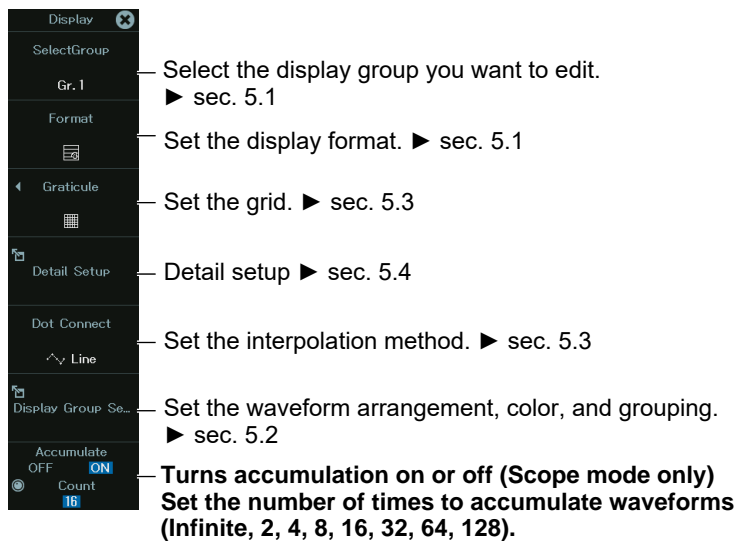

Setting Accumulation (Accumulate)

2. Tap **Accumulate**, or tap the soft key. If you set this to ON, the accumulation count appears.
3. Set the accumulation count by tapping the displayed accumulation count or by using the jog dial or up and down keys. If you set this to Infinite, accumulation will continue until acquisition is complete.

5.6 Using the Snapshot and Clear Trace Features

Items Common to Scope Mode and Recorder Mode

- Taking a snapshot
- Clearing the snapshot waveform

▶ [“Snapshot \(SNAPSHOT\)” and “Clear Trace \(CLEAR TRACE\)” in the Features Guide](#)

Snapshot

1. On the waveform screen's **MENU**, tap **OTHERS > SNAPSHOT**, or press **SNAPSHOT**. The currently displayed waveform is retained on the screen as a snapshot displayed in white. Snapshot waveforms remain on the screen until you execute a clear trace operation.

Clear Trace

1. On the waveform screen's **MENU**, tap **OTHERS > CLEAR TRACE**, or press **CLEAR TRACE**. All waveforms on the screen are cleared.

Chapter 6

X-Y display

Main Control Areas Used in This Chapter

You can also use the touch panel.

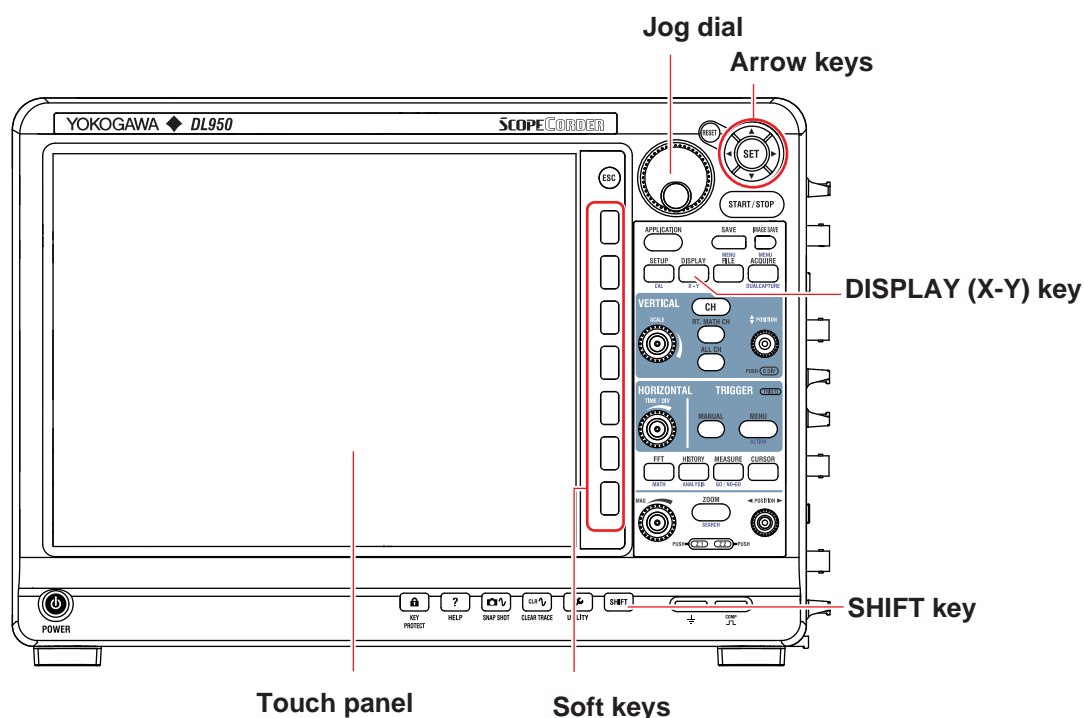

Operation Modes Applicable to the Sections in This Chapter

✓: Applicable, -: Not applicable

Section	Scope Mode	Recorder Mode
6.1 Setting the X-Y Waveform Trace	✓	✓
6.2 Setting the Display Conditions for X-Y Waveforms	✓	✓
6.3 Measuring X-Y Waveforms with Cursors	✓	✓

* The settings may vary depending on the operation mode.

6.1 Setting the X-Y Waveform Trace

This section explains the following settings for displaying X-Y waveforms:

Items Common to Scope Mode and Recorder Mode

- Turning X-Y waveform display on and off, source waveform (X axis, Y axis)
- Start and end points of display range

► [“X-Y Waveform Setup \(Setup\)” in the Features Guide](#)

X-Y menu

1. On the waveform screen’s **MENU**, tap **DISPLAY > X-Y**, or press **SHIFT+DISPLAY(X-Y)**. The X-Y menu appears.

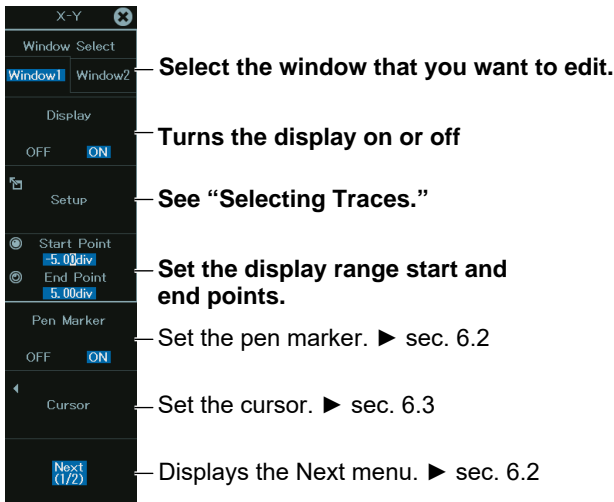

Selecting Traces

2. Tap **Setup**, or press the soft key. The following menu appears.

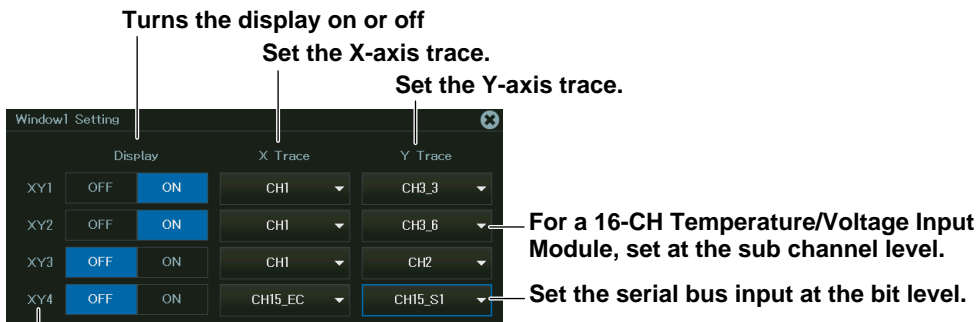

Set XY1 to XY4 on Window1 and XY5 to XY8 on Window2.

6.2 Setting the Display Conditions for X-Y Waveforms

This section explains the following settings for the display conditions of X-Y waveforms:

Items Common to Scope Mode and Recorder Mode

- Display range
- Turning pen markers on and off
- Main window's display ratio
- Window layout
- Turning combine display on and off
- Interpolation
- The number of data points that are used to display waveforms
- Turning trace-clear-on-start on and off

► [“X-Y Waveform Display” in the Features Guide](#)

X-Y menu

1. On the waveform screen's **MENU**, tap **DISPLAY > X-Y**, or press **SHIFT+DISPLAY(X-Y)**. The X-Y menu appears.

X-Y menu (1/2)

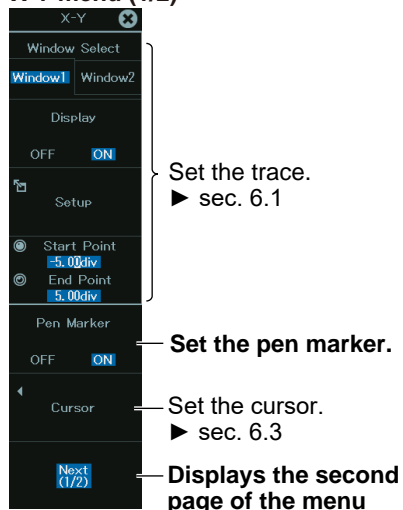

X-Y menu (2/2)

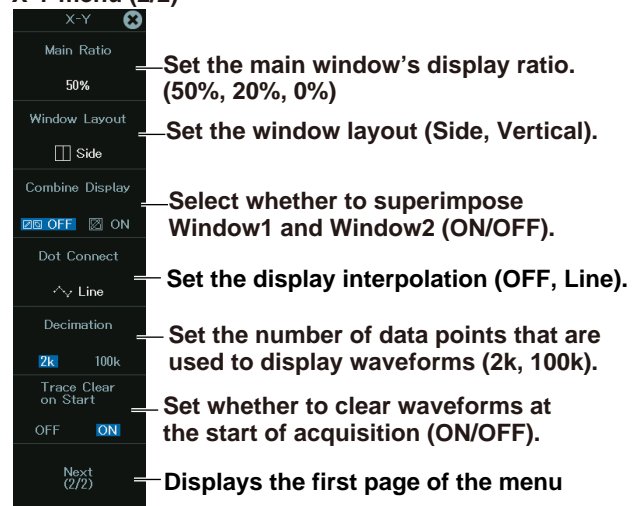

6.3 Measuring X-Y Waveforms with Cursors

This section explains the following settings for measuring X-Y waveforms with cursors for each cursor type:

Items Common to Scope Mode and Recorder Mode

- Turning cursor measurement on and off
- Cursor type
- Source waveform
- Moving cursors
- Measurement items
- Marker assignment
- Marker position

► “X-Y Waveform Cursor Measurement (Cursor)” in the Features Guide

X-Y Cursor Menu

1. On the waveform screen’s **MENU**, tap **DISPLAY > X-Y**, or press **SHIFT+DISPLAY(X-Y)**. The X-Y menu appears.
2. Tap **Cursor**, or tap the soft key.

X-Y menu (1/2)

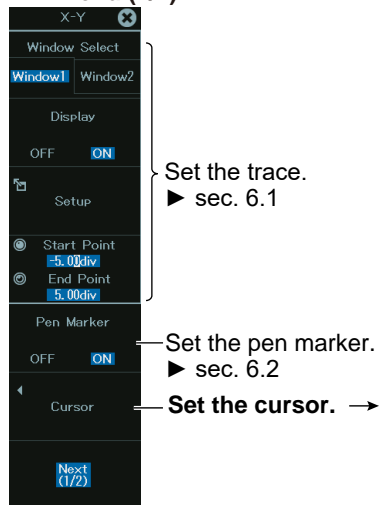

FFT cursor menu

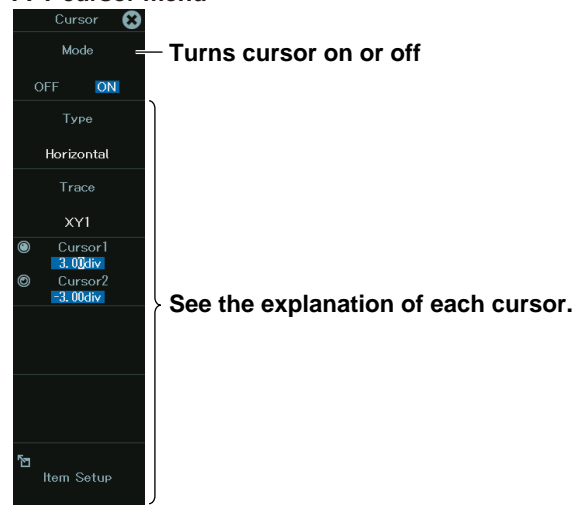

Measuring X-Y Waveforms with Horizontal Cursors (Horizontal)

3. Tap **Type**, or press the soft key to select **Horizontal**.

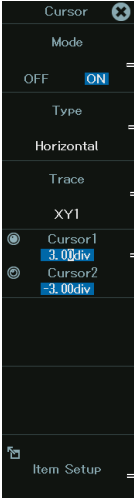

The screenshot shows the 'Cursor' menu with the following settings and annotations:

- Mode:** OFF (ON) — **Set Mode to ON.**
- Type:** Horizontal — **Set the cursor type to Horizontal (horizontal).**
- Trace:** XY1 — **Select the trace to measure with cursors (XY1 to XY8).**
- Cursor1:** 3.00div — **Set the cursor positions (Cursor1: Y1, Cursor2: Y2).**
- Cursor2:** -3.00div — **Set the cursor positions (Cursor1: Y1, Cursor2: Y2).**

You can also drag the cursors on the X-Y screen. Tap the cursor and then tap the arrow that appears (shown in the figure below) to adjust the cursor position in fine increments.



The icon shows a vertical double-headed arrow with the text 'Cursor Position' in the center.

Item Setup — **See “Setting Measurement Items.”**

Setting Measurement Items (Item Setup)

4. Tap **Item Setup**, or press the soft key. The following screen appears.

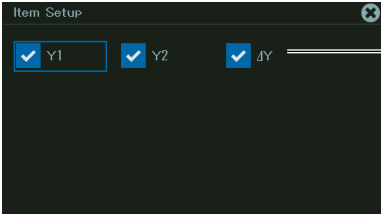

The screenshot shows the 'Item Setup' menu with the following settings:

- Y1
- Y2
- ΔY

Select the measurement items that you want to use.

- Y1: Vertical (Y axis) value at Cursor1
- Y2: Vertical (Y axis) value at Cursor2
- ΔY: Difference between the vertical (Y axis) values of Cursor1 and Cursor2

Measuring X-Y Waveforms with Vertical Cursors (Vertical)

3. Tap **Type**, or press the soft key to select **Vertical**.



Set Mode to ON.

Set the cursor type to Vertical (vertical).

Select the trace to measure with cursors (XY1 to XY8).

Set the cursor positions (Cursor1: X1, Cursor2: X2).

You can also drag the cursors on the X-Y screen. Tap the cursor and then tap the arrow that appears (shown in the figure below) to adjust the cursor position in fine increments.



See "Setting Measurement Items."

Setting Measurement Items (Item Setup)

4. Tap **Item Setup**, or press the soft key. The following screen appears.

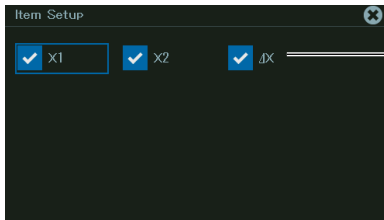

Select the measurement items that you want to use.

X1: Time (X axis) value at Cursor1

X2: Time (X axis) value at Cursor2

ΔX : Difference between the time (X axis) values of Cursor1 and Cursor2

Measuring X-Y Waveforms with Marker Cursors (Marker)

3. Tap **Type**, or press the soft key to select **Marker**.

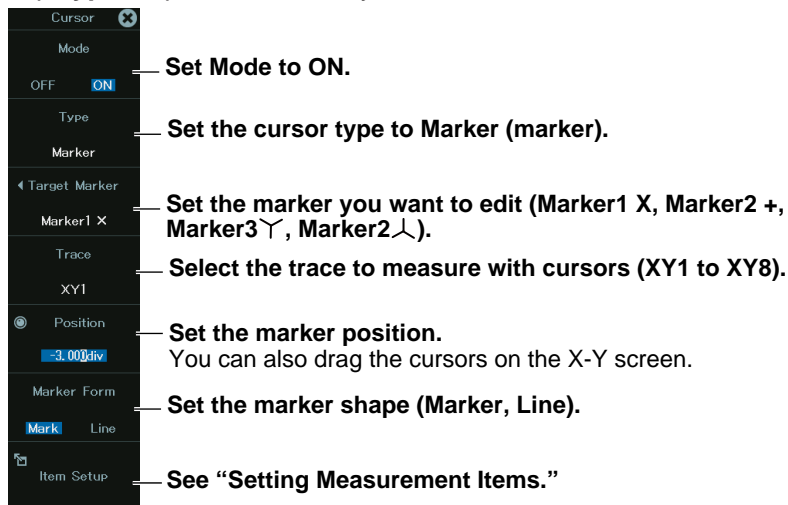

Setting Measurement Items (Item Setup)

4. Tap **Item Setup**, or press the soft key. The following screen appears.

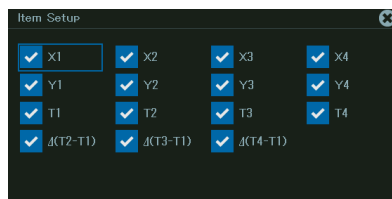

Select the measurement items that you want to use.

- X1: Horizontal (X axis) value at Marker1
- X2: Horizontal (X axis) value at Marker2
- X3: Horizontal (X axis) value at Marker3
- X4: Horizontal (X axis) value at Marker4
- Y1: Vertical (Y axis) value at Marker1
- Y2: Vertical (Y axis) value at Marker2
- Y3: Vertical (Y axis) value at Marker3
- Y4: Vertical (Y axis) value at Marker4
- T1: Time from the trigger position at Marker1
- T2: Time from the trigger position at Marker2
- T3: Time from the trigger position at Marker3
- T4: Time from the trigger position at Marker4
- $\Delta(T2-T1)$: Time difference between Marker1 and Marker2
- $\Delta(T3-T1)$: Time difference between Marker1 and Marker3
- $\Delta(T4-T1)$: Time difference between Marker1 and Marker4

Measuring X-Y Waveforms with Horizontal and Vertical Cursors (H & V)

3. Tap **Type**, or press the soft key to select **H & V**.

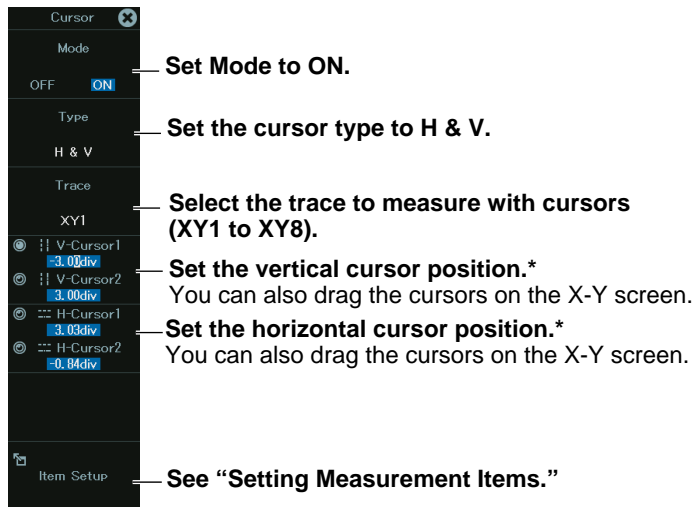

- * Tap the cursor and then tap the arrow that appears (shown in the figure below) to adjust the cursor position in fine increments.



Setting Measurement Items (Item Setup)

4. Tap **Item Setup**, or press the soft key. The following screen appears.

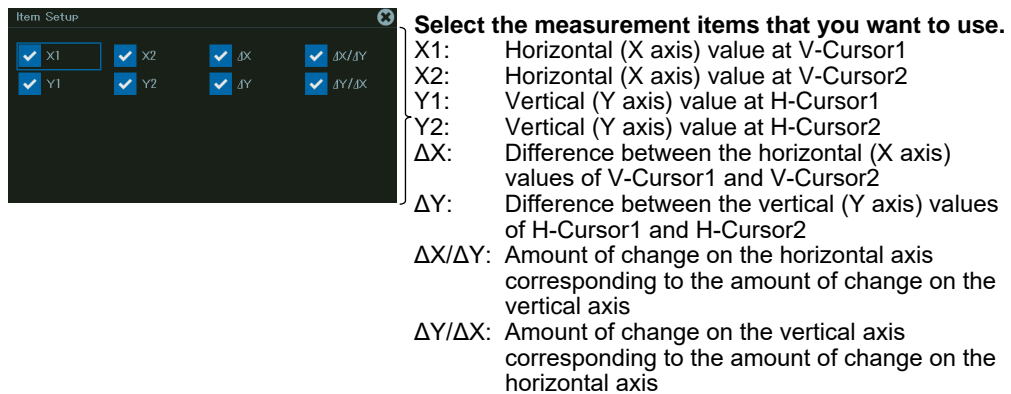

Chapter 7

Zooming In on or Out of Waveforms

Main Control Areas Used in This Chapter

You can also use the touch panel.

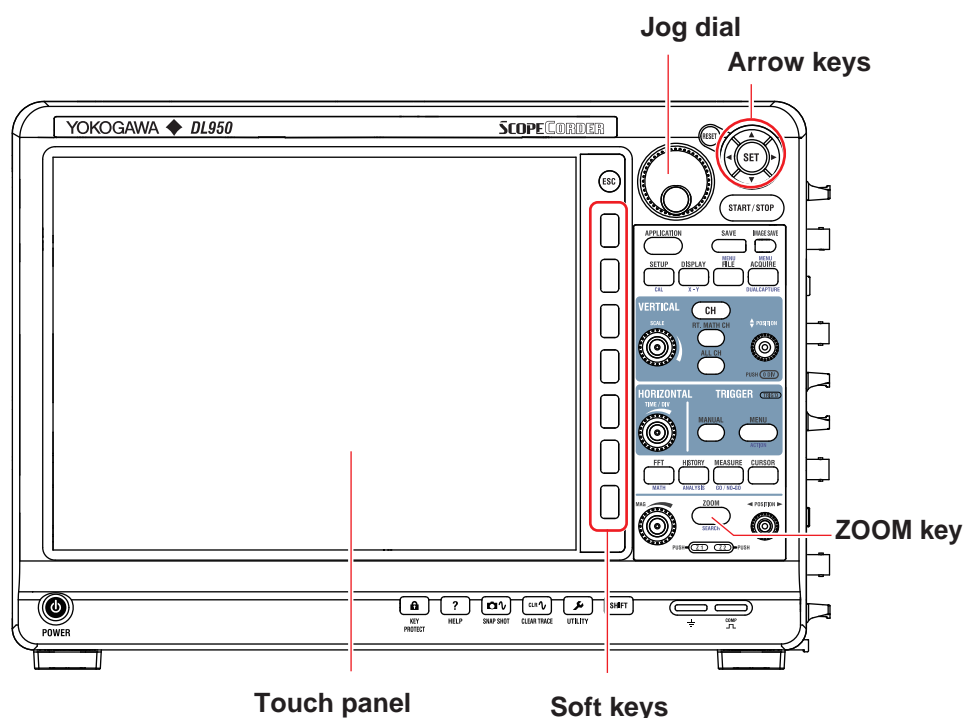

Operation Modes Applicable to the Sections in This Chapter

✓: Applicable, -: Not applicable

Section	Scope Mode	Recorder Mode
7.1 Zooming In on or Out of Waveforms (Scope mode)	✓	-
7.2 Zooming In on or Out of Waveforms (Recorder mode)	-	✓

* The settings may vary depending on the operation mode.

7.1 Zooming In on or Out of Waveforms (Scope mode)

This section explains the following settings for zooming in or out of waveforms in Scope mode:

Applicable to Scope Mode

- Setting the target (Zoom1, Zoom2)
- Turning zoom on and off
- Zoom source window (for Zoom2)
- Zoom position
- Display format
- Main window's display ratio
- Window layout
- Auto scroll
- Zoom source waveform
- Changing the range for performing automated measurement of waveform parameters
- Zoom factor

► [“Zooming In on or Out of Waveforms” in the Features Guide](#)

ZOOM Menu

1. On the waveform screen's MENU, tap **ANALYSIS** > **ZOOM**, or press **ZOOM**. The ZOOM menu appears.

If a zoom window is not displayed on the screen, zoom box 1 (Zoom1) is automatically turned on, and a zoom window appears.

To switch between Zoom1 and Zoom2, tap the **Zoom1** or **Zoom2** tab, or press the zoom **POSITION** or **MAG** knob.

Configuring Zoom1

ZOOM menu (page 1/2)

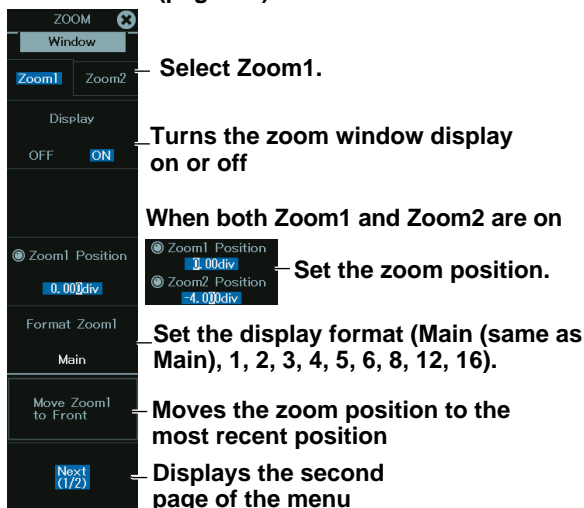

ZOOM menu (page 2/2)

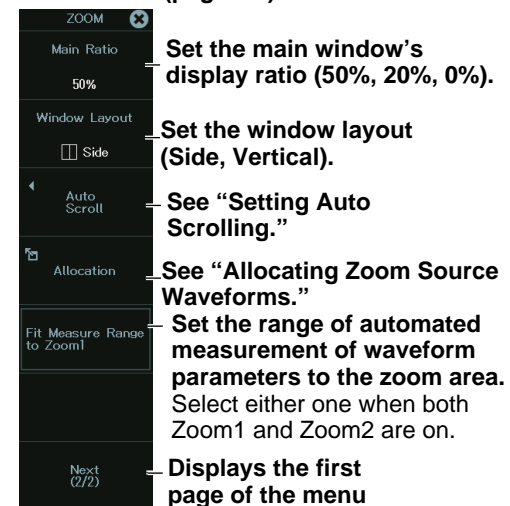

Configuring Zoom2

ZOOM menu (page 1/2)

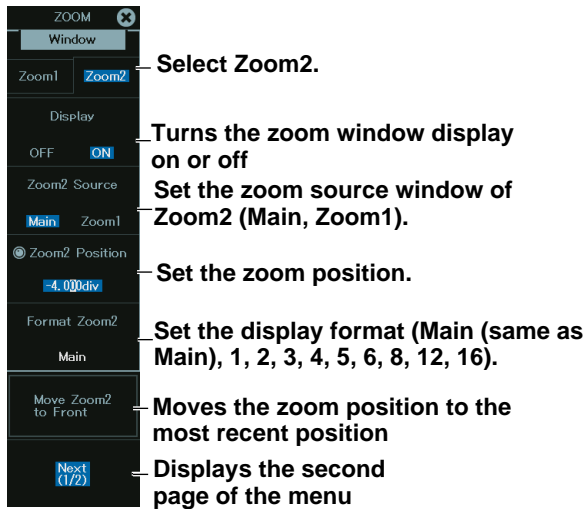

ZOOM menu (page 2/2)

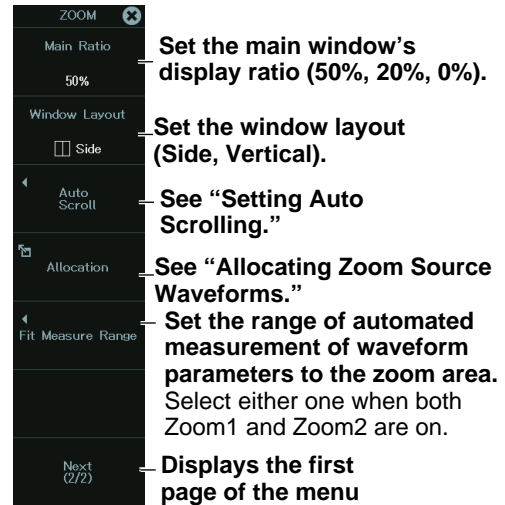

Setting Auto Scrolling (Auto Scroll)

2. Tap **Auto Scroll**, or press the soft key. The following menu appears.

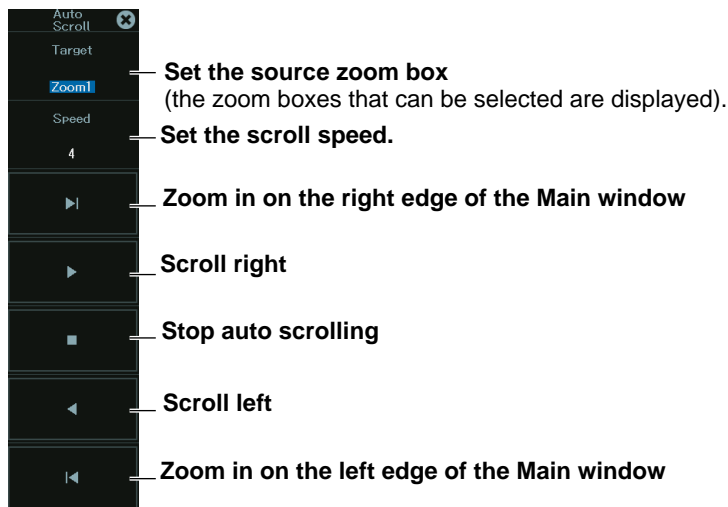

Allocating Zoom Source Waveforms (Allocation)

3. Tap **Allocation**, or press the soft key. The following screen appears.



Select the zoom source waveforms (the waveforms that can be selected are displayed).

Zoom Factor (MAG knob)

Use the **MAG** knob to set the zoom factor.

The **MAG** knob controls the waveforms in the window whose corresponding indicator, Z1 or Z2, is illuminated.

The **MAG** knob has a push switch. Push the knob to illuminate the Z1 indicator, Z2 indicator, or both indicators. Then, you can set the zoom factor. When both the Z1 and Z2 indicators are illuminated, you can set both zoom windows to the same zoom factor at the same time.

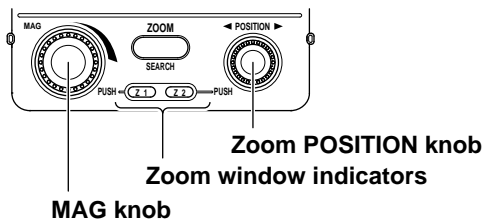

Setting the Zoom Position (Zoom POSITION knob)

Use the **zoom POSITION** knob to set the zoom position.

The zoom **POSITION** knob controls the waveforms in the window whose corresponding indicator, Z1 or Z2, is illuminated.

The zoom **POSITION** knob has a push switch. Push the knob to illuminate the Z1 indicator, Z2 indicator, or both indicators. Then, you can set the zoom position. When both the Z1 and Z2 indicators are illuminated, you can set the zoom positions of both windows at the same time while retaining the positional relationship between the two.

7.2 Zooming In on or Out of Waveforms (Recorder mode)

This section explains the following settings for zooming in or out of waveforms in Recorder mode:

Applicable in Recorder Mode

- Turning zoom on and off
- Zoom position
- Display range (zoom factor)
- Display format
- Main window's display ratio
- Window layout
- Auto scroll
- Zoom source waveform
- Changing the range for performing automated measurement of waveform parameters

► [“Zooming in on or Out of Waveforms” in the Features Guide](#)

ZOOM Menu

1. On the waveform screen's MENU, tap **ANALYSIS > ZOOM**, or press **ZOOM**. The ZOOM menu appears.

ZOOM menu (page 1/2)



See “Switching between the Main Window and Zoom Window.”

ZOOM menu (page 2/2)



Set the main window's display ratio (50%, 20%, 0%).

Set the window layout (Side, Vertical).

See “Setting Auto Scrolling.”

See “Allocating Zoom Source Waveforms.”

Set the range of automated measurement of waveform parameters to the zoom area.

Displays the first page of the menu

Switching between the Main Window and Zoom Window

2. Tap the Main or Zoom tab, or press the zoom POSITION knob. The selected tab switches.

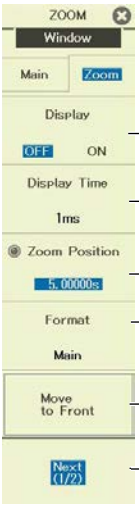
Main window menu	Zoom window menu
 <p>Window</p> <p>Main Zoom</p> <p>Display Time 10s</p> <p>Position 5.00000s</p> <p>Move to Front</p> <p>Next (1/2)</p>	 <p>Window</p> <p>Main Zoom</p> <p>Display OFF ON</p> <p>Display Time 1ms</p> <p>Zoom Position 5.00000s</p> <p>Format Main</p> <p>Move to Front</p> <p>Next (1/2)</p>
<p>— Set the main window's display time period.</p> <p>— Set the center position of the main window.</p> <p>— Moves to the beginning of the waveform</p> <p>— Displays the second page of the menu</p>	<p>— Turns the zoom window on or off</p> <p>— Set the zoom window's display time period.</p> <p>— Set the center position of the zoom window.</p> <p>— Set the display format (Main (same as Main), 1, 2, 3, 4, 5, 6, 8, 12, 16).</p> <p>— Moves to the beginning of the waveform</p> <p>— Displays the second page of the menu</p>

Setting Auto Scrolling (Auto Scroll)

2. Press the **Auto Scroll** soft key. The following menu appears.

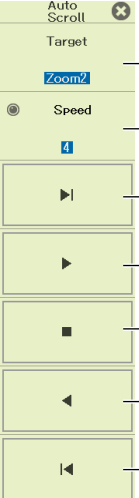
 <p>Auto Scroll</p> <p>Target Zoom2</p> <p>Speed 4</p> <p>▶</p> <p>▶</p> <p>■</p> <p>◀</p> <p>◀</p>	<p>— Target zoom box</p> <p>— Set the scroll speed.</p> <p>— Zoom in on the right edge of the Main window</p> <p>— Scroll right</p> <p>— Stop auto scrolling</p> <p>— Scroll left</p> <p>— Zoom in on the left edge of the Main window</p>
--	--

Allocating Zoom Source Waveforms (Allocation)

3. Press the **Allocation** soft key. The following screen appears.

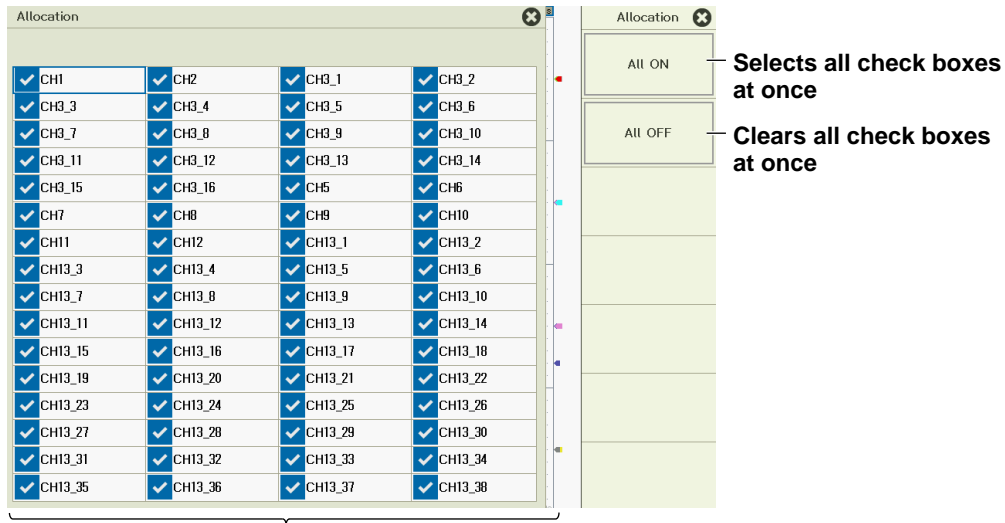

Select the zoom source waveforms (the waveforms that can be selected are displayed).

The selected waveforms are displayed in the zoom window.

Setting the Display Range with the MAG Knob

You can also set the display range with the **MAG** knob.

The **MAG** knob controls the waveforms in the window whose corresponding indicator, Z1 or Z2, is illuminated. In Recorder mode, the **MAG** knob controls the main window when Z1 is illuminated and the zoom window when Z2 is illuminated.

The **MAG** knob has a push switch. Push the knob to illuminate the Z1 indicator, Z2 indicator, or both indicators. Then, you can set the zoom factor. When both the Z1 and Z2 indicators are illuminated, you can set both the main window and zoom window at the same time.

When the zoom window display is off, only Z1 illuminates.

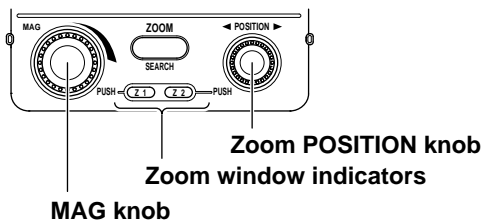

Setting the Window's Center Position with the Zoom POSITION Knob

You can also set the window's center position with the zoom **POSITION** knob.

The zoom **POSITION** knob controls the waveforms in the window whose corresponding indicator, Z1 or Z2, is illuminated.

The zoom **POSITION** knob has a push switch. Push the knob to illuminate the Z1 indicator, Z2 indicator, or both indicators. Then, you can set the window's center position. When both the Z1 and Z2 indicators are illuminated, you can set both the main window and zoom window at the same time. When the zoom window display is off, only Z1 illuminates.

Chapter 8

Searching Waveforms

Main Control Areas Used in This Chapter

You can also use the touch panel.

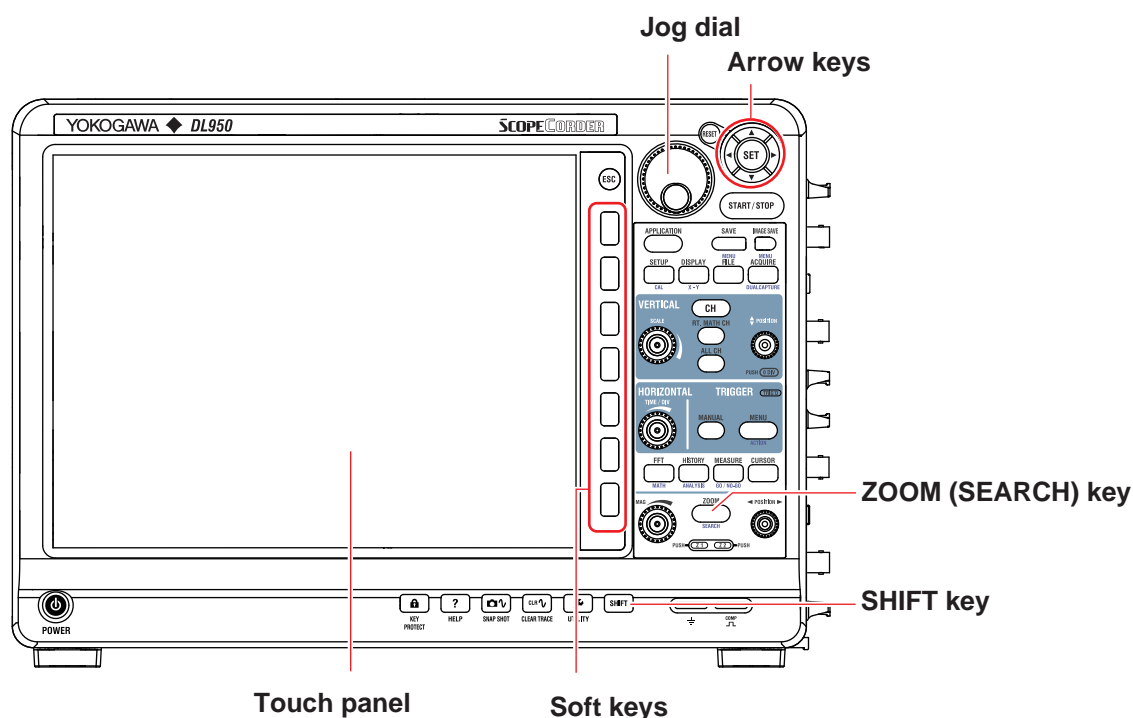

Operation Modes Applicable to the Sections in This Chapter

✓: Applicable, -: Not applicable

Section	Scope Mode	Recorder Mode
8.1 Searching for Edges	✓	✓
8.2 Searching for Events	✓	✓
8.3 Searching for Logic Patterns	✓	✓
8.4 Searching for a Specific Date and Time	✓	✓

* The settings may vary depending on the operation mode.

8.1 Searching for Edges

This section explains the following settings for searching for edges:

Items Common to Scope Mode and Recorder Mode

- Search type
- Search conditions (source waveform, level for determining the state of the source waveform, edge polarity, hysteresis, and the number of times to detect the conditions)
- Detected waveform display window (Scope mode)
- Detected point number
- Search range
- Executing searches

► [“Edge Search \(Edge\)” in the Features Guide](#)

SEARCH Edge Menu

1. On the waveform screen’s MENU, tap **ANALYSIS > SEARCH**, or press **SHIFT+ZOOM (SEARCH)**.
2. Set Type to **Edge**.

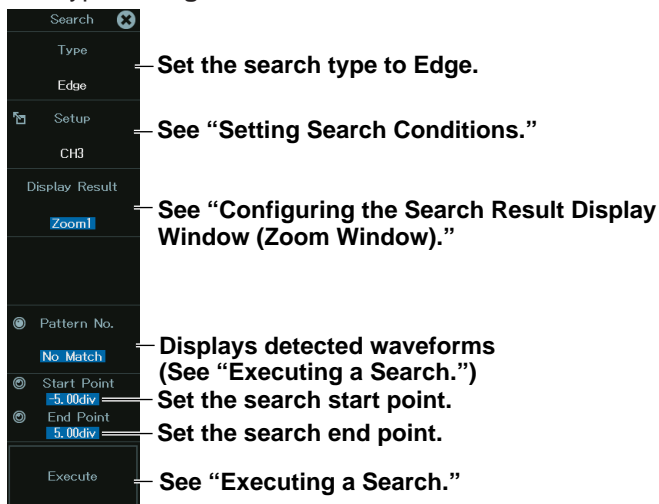

Setting Search Conditions (Setup)

- Press the **Setup** soft key. A menu appears according to the waveform to be searched you specified.

When the waveform to search is set to CH1 to CH16, 16CH TEMP/VOLT, CAN,* CAN FD,* LIN,* SENT*

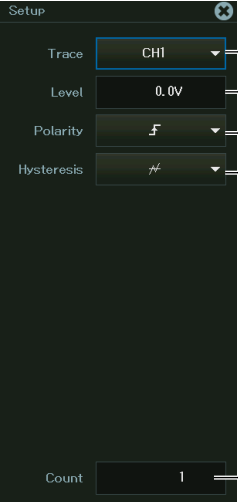

The screenshot shows the 'Setup' menu with the following settings and annotations:

- Trace:** CH1. Annotation: Set the waveform to search (CH1 to CH16, 16CH TEMP/VOLT, CAN, CAN FD, LIN, SENT).
- Level:** 0.0V. Annotation: Set the level.
- Polarity:** \uparrow . Annotation: Set the edge polarity (\uparrow , \downarrow , $\uparrow\downarrow$).
- Hysteresis:** \neq . Annotation: Set the hysteresis (\neq , \approx , \approx).
- Count:** 1. Annotation: Set the number of times to detect the conditions.

* Use this menu for waveforms whose sub channel Value Type on the CAN bus monitor, CAN/CAN FD monitor, or CAN & LIN bus monitor is Unsigned, Signed, or Float and waveforms whose sub channel on the SENT monitor is FastCH, SlowCH, or Error Count.

If the Waveform to Search Is Set to a Logic Channel

- Waveforms of logic input modules
- Waveforms whose sub channel Value Type on the CAN bus monitor, CAN/CAN FD monitor, or CAN & LIN bus monitor is Logic
- Waveforms whose sub channel on the SENT monitor is S&C or Error Trigger

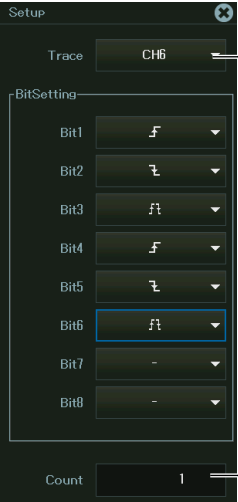

The screenshot shows the 'Setup' menu with the following settings and annotations:

- Trace:** CH6. Annotation: Set the search source waveform (a logic channel).
- BitSetting:**
 - Bit1: \uparrow
 - Bit2: \downarrow
 - Bit3: $\uparrow\downarrow$
 - Bit4: \uparrow
 - Bit5: \downarrow
 - Bit6: $\uparrow\downarrow$ (highlighted)
 - Bit7: -
 - Bit8: -
- Count:** 1. Annotation: Set the number of times to detect the conditions.

Annotation for BitSetting: Set the polarity of each bit (\uparrow , \downarrow , $\uparrow\downarrow$, - (don't use as a search condition)).

Configuring the Search Result Display Window (Zoom Window) (Display Result) (Scope mode)

Set which zoom window, Z1 or Z2, to display the found waveform in. You can configure zoom windows Z1 and Z2 when they are displayed. If both Z1 and Z2 are not displayed, Z1 will be displayed when you press **SHIFT+ZOOM** (SEARCH) to display the SEARCH menu.

Executing a Search (Execute)

4. Tap **Execute**, or press the soft key. The instrument executes the search.

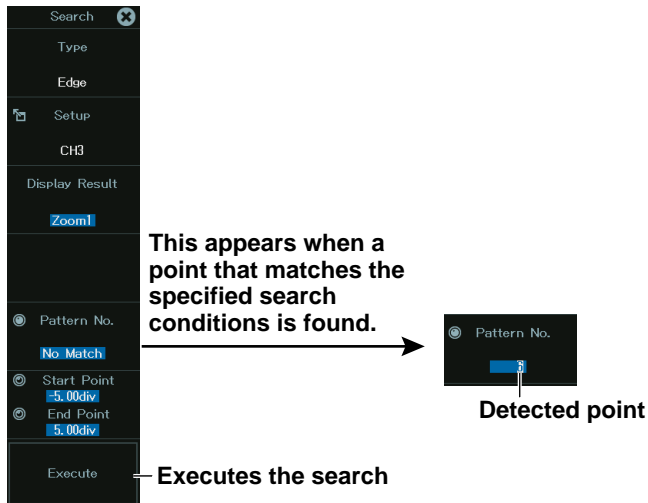

Executing and Aborting a Search

After setting the search conditions, tap **Execute**, or press the soft key. The search is executed, and the soft key changes to Abort. If the instrument finds points that match the search conditions (detected points), it shows numbers (0, 1, 2, etc.) from the left of the waveform display in the order that the points were detected.

To abort a search, tap **Abort**, or press the soft key.

Setting the Detected Point Numbers

You can set the detected point number and display the waveform with the detected point in the center of the zoom window.

8.2 Searching for Events

This section explains the following settings for searching for events):

Items Common to Scope Mode and Recorder Mode

- Search type
- Search source
- Event number

► “Event Search (Event)” in the Features Guide

SEARCH Event Menu

1. On the waveform screen’s MENU, tap **ANALYSIS > SEARCH**, or press **SHIFT+ZOOM (SEARCH)**.
2. Set Type to Event.

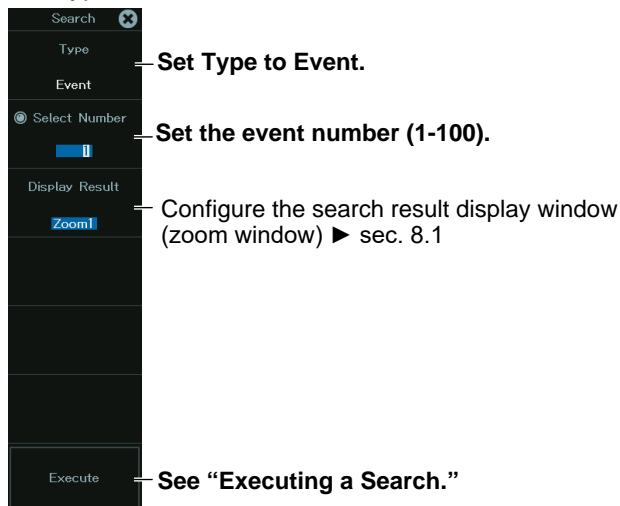

Executing a Search (Execute)

3. Tap **Execute**, or press the soft key. The instrument executes the search.

8.3 Searching for Logic Patterns

This section explains the following settings for searching for logic patterns:

Items Common to Scope Mode and Recorder Mode

- Search type
- Search conditions

Source waveform, source bits, and the number of times to detect the conditions

► [“Logic Pattern Search \(Logic Pattern\)” in the Features Guide](#)

SEARCH Logic Pattern Menu

1. On the waveform screen’s MENU, tap **ANALYSIS > SEARCH**, or press **SHIFT+ZOOM (SEARCH)**.
2. Set Type to **Logic Pattern**. If a logic module is not installed, you cannot select Logic Pattern.

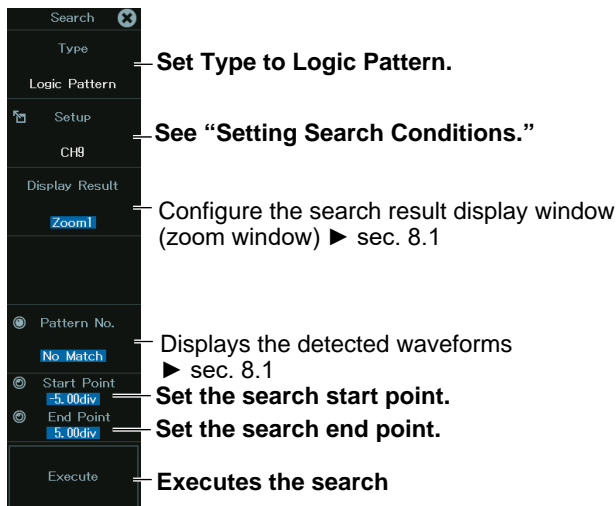

Setting Search Conditions (Setup)

3. Tap **Setup**, or press the soft key. The following screen appears.

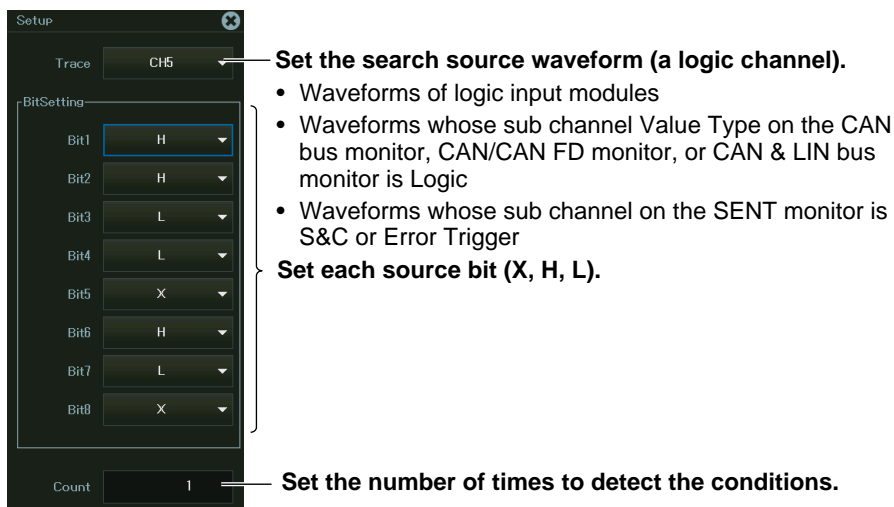

Executing a Search (Execute)

4. Tap **Execute**, or press the soft key. The instrument executes the search.

8.4 Searching for a Specific Date and Time

This section explains the following settings for searching for a specific date and time:

Items Common to Scope Mode and Recorder Mode

- Search type
- Date and time

► [“Time Search \(Time\)” in the Features Guide](#)

SEARCH Time menu

1. On the waveform screen’s MENU, tap **ANALYSIS > SEARCH**, or press **SHIFT+ZOOM (SEARCH)**.
2. Set Type to **Time**.

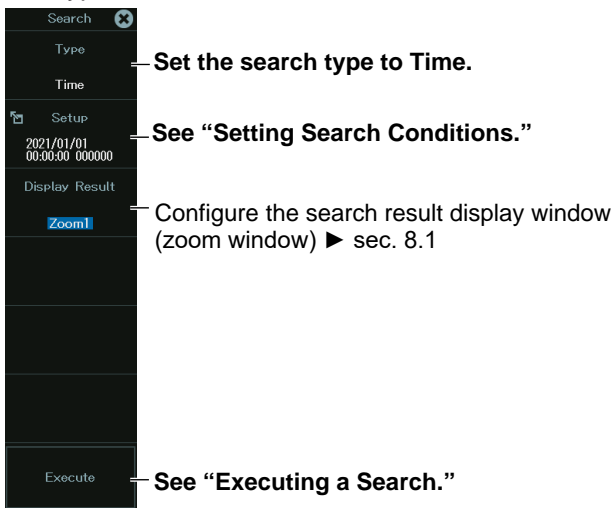

Setting Search Conditions (Setup)

3. Tap **Setup**, or press the soft key. The following screen appears.

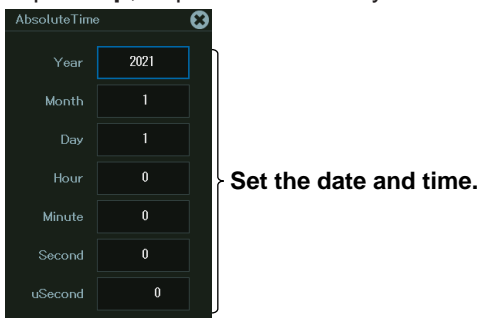

Executing a Search (Execute)

4. Tap **Execute**, or press the soft key. The instrument executes the search.

Chapter 9

History Waveform Display/Search (Scope mode only)

Main Control Areas Used in This Chapter

You can also use the touch panel.

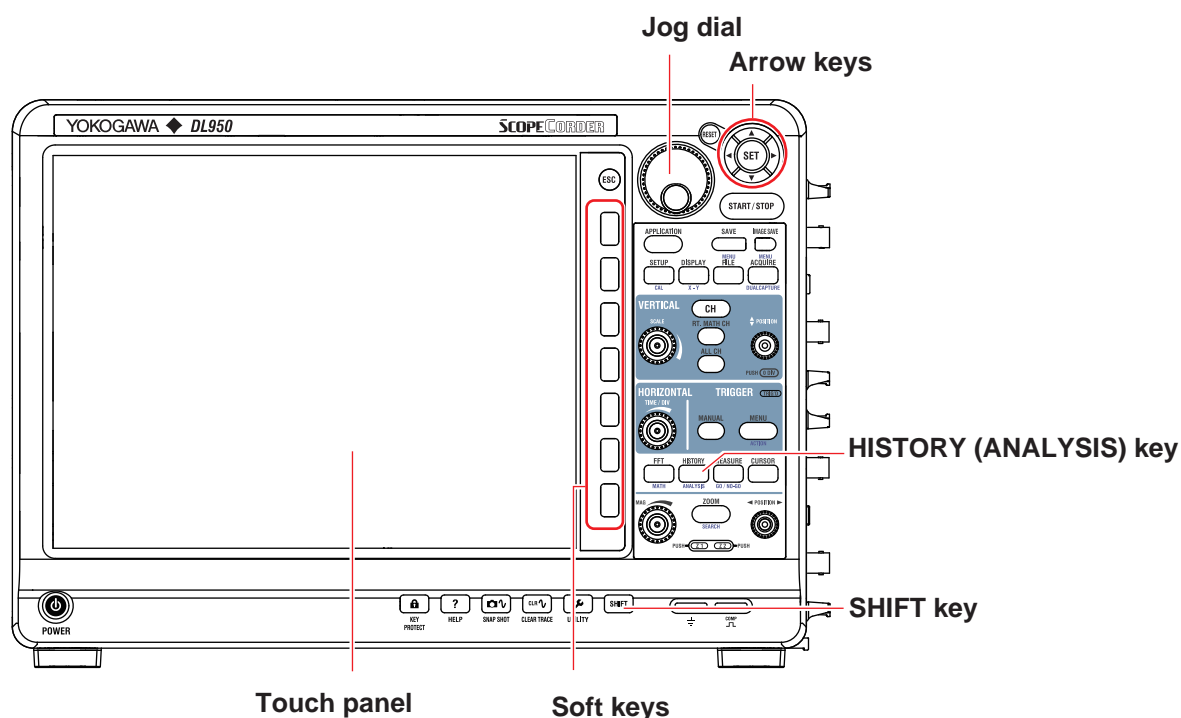

Operation Modes Applicable to the Sections in This Chapter

✓: Applicable, -: Not applicable

Section	Scope Mode	Recorder Mode
9.1 Displaying Waveform History Waveforms	✓	-
9.2 Searching History Waveforms	✓	-

* The settings may vary depending on the operation mode.

9.1 Displaying Waveform History Waveforms

This section explains the following settings for displaying history waveforms, which are waveforms that were previously saved to acquisition memory:

Applicable to Scope Mode

- Display mode
- Highlighting the selected record number
- Display range (start and end record numbers)
- Showing a list of timestamps
- Clearing all history waveforms

► “History Waveform Display/Search (Scope mode only)” in the Features Guide

HISTORY menu

1. On the waveform screen’s MENU, tap **ANALYSIS > HISTORY**, or press **HISTORY (ANALYSIS)**.

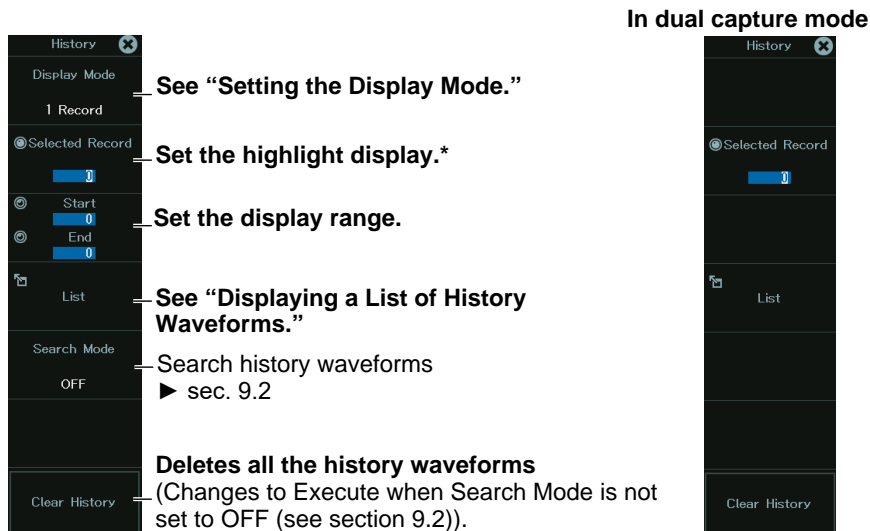

* This setting only appears when Display Mode is set to 1 Record or All Record.

Setting the Display Mode (Display Mode)

2. Tap **Display Mode**, or press the soft key.

From the menu that appears, select the display mode.

1 Record: Only the waveform corresponding to the selected record number is displayed.¹

All Record: All selected waveforms are superimposed on each other.²

All other waveforms¹ are displayed with an intermediate color.

Average Record: Computes the linear average of all the selected waveforms² and displays the result.

1 Specify the highlighted waveform with Selected Record.

2 Specify with Start Record and End Record.

Note

- After you execute a search on the history waveforms, the only waveforms that are displayed are those that meet the search conditions. To display all the history waveforms in acquisition memory again, turn the history waveform search feature off.
- The averaging feature requires a certain amount of acquisition memory. If this is not available, you will not be able to display the Average Record.

Displaying a List of History Waveforms (List)

2. Tap **List**, or press the soft key. A list of history waveforms appears.

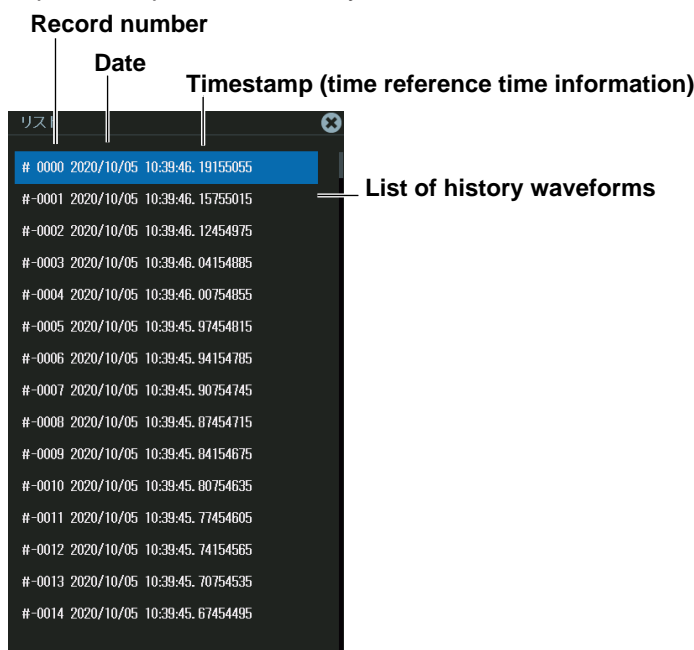
**Note****Notes on Using the History Feature**

- When the acquisition mode is set to Average, you cannot use the history feature.
- If you stop waveform acquisition, even if one complete screen's worth of waveform data has not been acquired, the waveform at which the trigger occurred is displayed as a single history waveform.
- You can start waveform acquisition when the History menu is displayed. However, you cannot change the history feature settings while waveform acquisition is in progress.
- The settings are restricted so that the following relationship is retained: Last record (End Record) \leq Selected Record \leq first record (Start Record).
- When you load waveform data from the specified storage device, history waveforms up to that point are cleared. The loaded waveform data is placed in record number zero. If you load a file containing multiple history waveforms, the latest waveform is placed in zero, and earlier waveforms are placed in order to record numbers -1 , -2 , and so on.
- Computation and automated measurement of waveform parameters are performed on the waveform of the record number specified by Selected Record. You can analyze old data as long as you do not overwrite the acquisition memory contents by restarting waveform acquisition. If Display Mode is set to Average Record, analysis is performed on the averaged waveform.
- History waveforms are cleared when you turn the power off.

9.2 Searching History Waveforms

This section explains the following settings for searching history waveforms:

Applicable to Scope Mode

- Search mode
- Executing searches

Zone

- Target zone (Zone1 to Zone4)
- Search conditions
- Search window (upper and lower limits, left and right boundary values)
- Search logic

Parameter

- Target parameter (Param1 to Param4)
- Search conditions
- Source waveform and parameter
- Reference range (upper and lower limits)
- Search logic
- Parameter measurement range

► [“History Waveform Display/Search \(Scope mode only\)” in the Features Guide](#)

HISTORY menu

1. On the waveform screen’s MENU, tap **ANALYSIS > HISTORY**, or press **HISTORY (ANALYSIS)**.

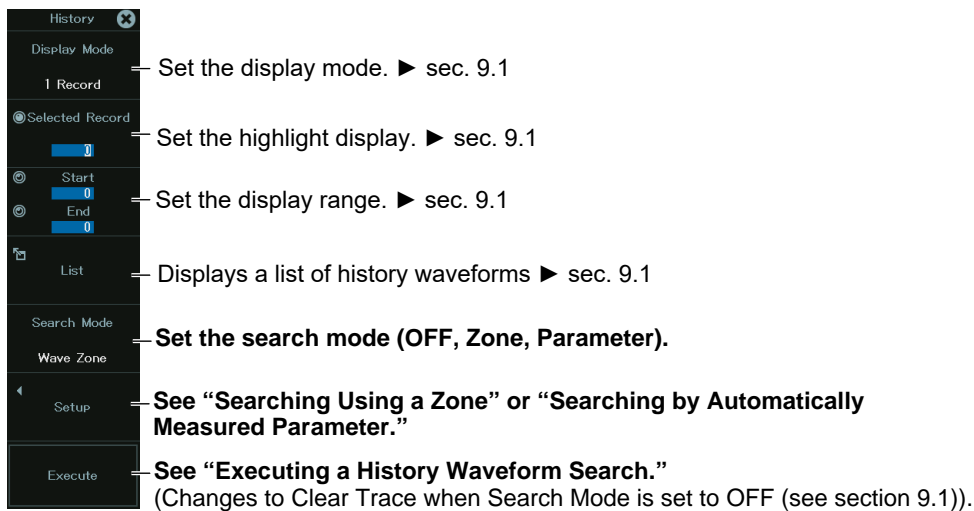

Searching Using a Zone

2. Tap **Search Mode**, or press the soft key. On the menu that appears, set Search Mode to **Wave Zone**.
3. Tap **Search Setup**, or press the soft key. The following screen appears.

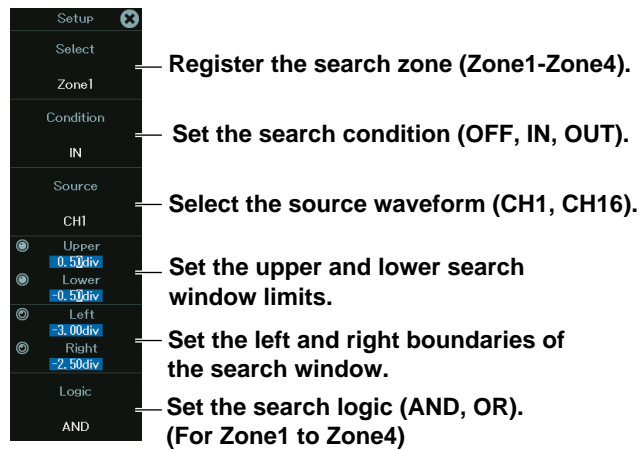

For items other than Logic, set for each zone.

Executing a History Waveform Search

4. After you set all the search conditions, close the menu to return to the HISTORY menu.
5. Tap **Execute**, or press the soft key. The instrument searches for the search conditions. The soft key changes to **Abort**.
To abort a search, tap **Abort**, or press the soft key.

Searching by Automatically Measured Parameter (Search Setup)

2. Tap **Search Mode**, or press the soft key. On the menu that appears, Search Mode to Parameter.
3. Tap **Search Setup**, or press the soft key. The following screen appears.

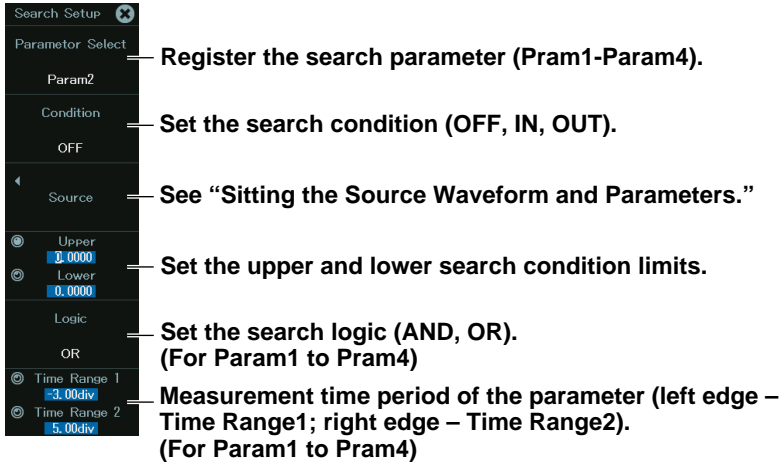

For all items other than Logic and Time Range 1, 2, set for each Param.

Sitting the Source Waveform and Parameters (Source)

4. Press the **Source** soft key. The following menu appears.

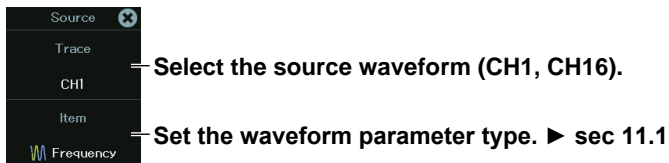

Executing a History Waveform Search

5. After you set all the search conditions, close the menu to return to the HISTORY menu.
6. Tap **Execute**, or press the soft key. The instrument searches for the search conditions. The soft key changes to Abort.
To abort a search, tap **Abort**, or press the soft key.

Chapter 10

Cursor Measurement

Main Control Areas Used in This Chapter

You can also use the touch panel.

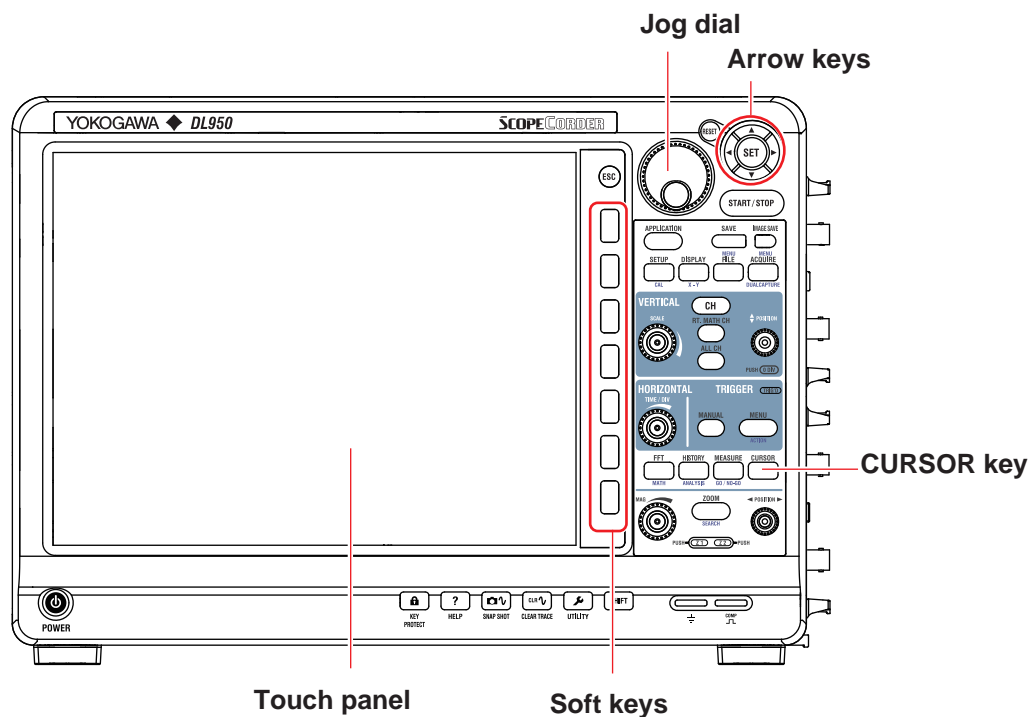

Operation Modes Applicable to the Sections in This Chapter

✓: Applicable, -: Not applicable

Section	Scope Mode	Recorder Mode
10.1 Measuring with Horizontal Cursors	✓	✓
10.2 Measuring with Vertical Cursors	✓	✓
10.3 Measuring with Marker Cursors (Marker)	✓	✓
10.4 Measuring with Angle Cursors (Degree)	✓	✓
10.5 Measuring with Horizontal and Vertical Cursors (H & V)	✓	✓

* The settings may vary depending on the operation mode.

10.1 Measuring with Horizontal Cursors

This section explains the following settings for measuring T-Y waveforms with horizontal cursors:
For information on cursor measurement on X-Y waveforms, see chapter 6.3.

Items Common to Scope Mode and Recorder Mode

- Turning the cursors on and off
- Cursor type
- Source waveform
- Cursor position
- Measurement items
- Cursor intensity

► [“Horizontal Cursors \(Horizontal\)” in the Features Guide](#)

CURSOR Horizontal menu

1. On the waveform screen’s MENU, tap **ANALYSIS** > **CURSOR**, or press **CURSOR**.
2. Tap **Mode**, or press the soft key to select **ON**.
3. Tap **Type**, or press the soft key to select **Horizontal**.

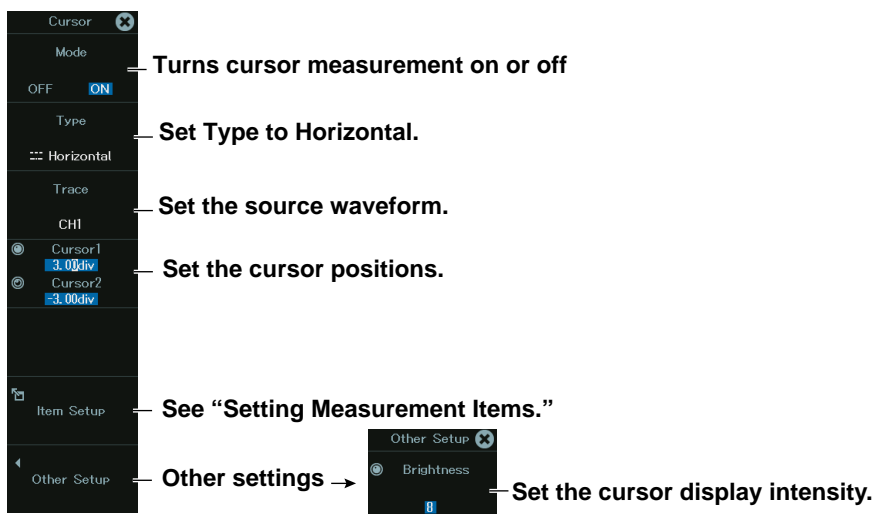

Setting Measurement Items (Item Setup)

4. Tap **Item Setup**, or press the soft key. The following screen appears.

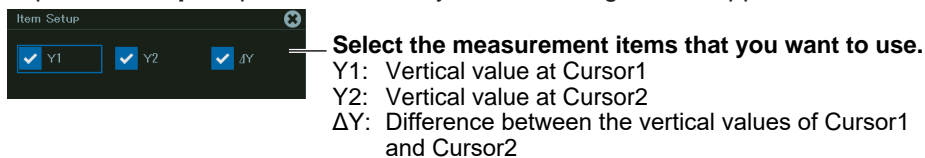

10.2 Measuring with Vertical Cursors

This section explains the following settings for measuring T-Y waveforms with vertical cursors:
For information on cursor measurement on X-Y waveforms, see chapter 6.3.

Items Common to Scope Mode and Recorder Mode

- Turning the cursors on and off
- Cursor type
- Source waveform
- Cursor position
- Measurement items
- Cursor value read mode
- Cursor intensity

► “Vertical Cursors (Vertical)” in the Features Guide

CURSOR Vertical menu

1. On the waveform screen’s MENU, tap **ANALYSIS** > **CURSOR**, or press **CURSOR**.
2. Tap **Mode**, or press the soft key to select **ON**.
3. Tap **Type**, or press the soft key to select **Vertical**.

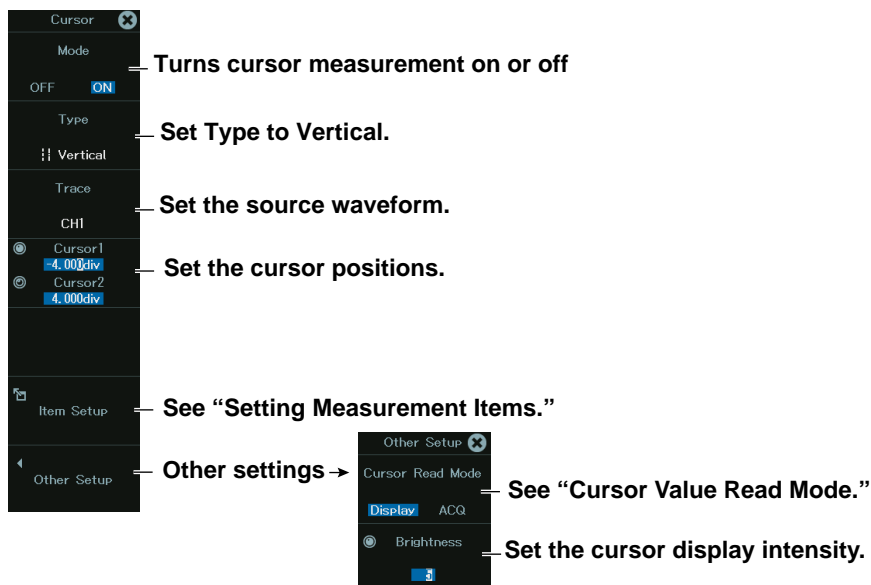

Setting Measurement Items (Item Setup)

4. Tap **Item Setup**, or press the soft key. The following screen appears.

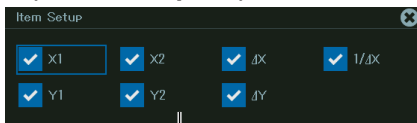

Select the measurement items that you want to use.

X1: Time value at Cursor1

X2: Time value at Cursor2

ΔX : Difference between the time values of Cursor1 and Cursor2

$1/\Delta X$: Reciprocal of the difference between the time values of Cursor1 and Cursor2

Y1: Vertical value at the intersection of Cursor1 and the waveform

Y2: Vertical value at the intersection of Cursor2 and the waveform

ΔY : Difference in the vertical values at the intersection of Cursor1/Cursor2 and the waveform

Cursor Value Read Mode

4. Tap **Other Setup**, or press the soft key.

5. Tap **Cursor Read Mode**, or press the soft key to set the cursor value read mode.

The two modes available for reading Y1 and Y2 measurements are Display (display data) or ACQ (acquisition data).

Display: The screen is divided into 1001 parts, and the maximum and minimum values displayed on those rasters are read.

ACQ: Measurement data acquired at the sample rate of each waveform is read. When all traces are selected, measurement data acquired at the sample rate calculated from T/div and record length is read.

10.3 Measuring with Marker Cursors (Marker)

This section explains the following settings for measuring T-Y waveforms with marker cursors:
For information on cursor measurement on X-Y waveforms, see chapter 6.3.

Items Common to Scope Mode and Recorder Mode

- Turning the cursors on and off
- Cursor type
- Marker type
- Measurement source waveform
- Cursor position
- Measurement items
- Marker form
- Cursor value read mode
- Cursor intensity

► “Marker Cursors (Marker)” in the Features Guide

CURSOR Marker menu

1. On the waveform screen’s MENU, tap **ANALYSIS** > **CURSOR**, or press **CURSOR**.
2. Tap **Mode**, or press the soft key to select **ON**.
3. Tap **Type**, or press the soft key to select **Marker**.

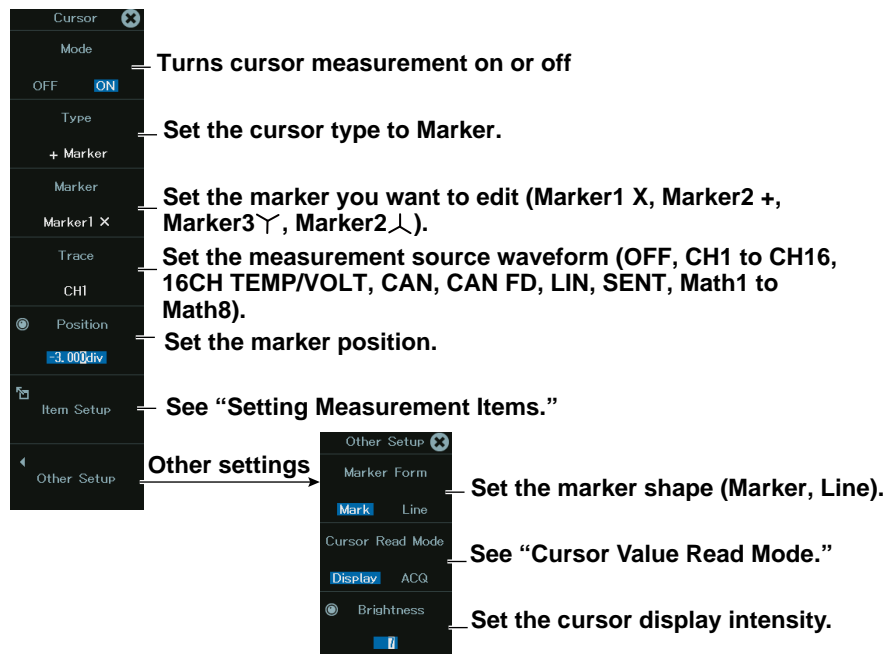

Setting Measurement Items (Item Setup)

4. Tap **Item Setup**, or press the soft key. The following screen appears.

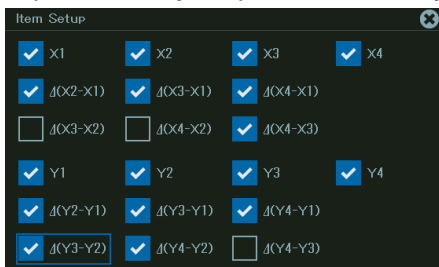

Select the measurement items that you want to use.

- X1 Time value at Marker1
- X2 Time value at Marker2
- X3 Time value at Marker3
- X4 Time value at Marker4
- $\Delta(X2-X1)$ Difference between the time values of Marker1 and Marker2
- $\Delta(X3-X1)$ Difference between the time values of Marker1 and Marker3
- $\Delta(X4-X1)$ Difference between the time values of Marker1 and Marker4
- $\Delta(X3-X2)$ Difference between the time values of Marker2 and Marker3
- $\Delta(X4-X2)$ Difference between the time values of Marker2 and Marker4
- $\Delta(X4-X3)$ Difference between the time values of Marker3 and Marker4
- Y1 Vertical value at Marker1
- Y2 Vertical value at Marker2
- Y3 Vertical value at Marker3
- Y4 Vertical value at Marker4
- $\Delta(Y2-Y1)$ Difference between the vertical values of Marker1 and Marker2
- $\Delta(Y3-Y1)$ Difference between the vertical values of Marker1 and Marker3
- $\Delta(Y4-Y1)$ Difference between the vertical values of Marker1 and Marker4
- $\Delta(Y3-Y2)$ Difference between the vertical values of Marker2 and Marker3
- $\Delta(Y4-Y2)$ Difference between the vertical values of Marker2 and Marker4
- $\Delta(Y4-Y3)$ Difference between the vertical values of Marker3 and Marker4

Cursor Value Read Mode

4. Tap **Other Setup**, or press the soft key.

5. Tap **Cursor Read Mode**, or press the soft key to set the marker value read mode.

The two modes available for reading Y1 and Y2 measurements are Display (display data) or ACQ (acquisition data).

Display: The screen is divided into 1001 parts, and the maximum and minimum values displayed on those rasters are read.

ACQ: Measurement data acquired at the sample rate of each waveform is read. When all traces are selected, measurement data acquired at the sample rate calculated from T/div and record length is read.

10.4 Measuring with Angle Cursors (Degree)

This section explains the following settings for measuring T-Y waveforms with angle cursors:

Items Common to Scope Mode and Recorder Mode

- Turning the cursors on and off
- Cursor type
- Source waveform
- Cursor position
- Reference cursor position
- Measurement items
- Reference angle
- Cursor value read mode
- Cursor intensity

► “Angle Cursors (Degree)” in the Features Guide

CURSOR Degree menu

1. On the waveform screen’s MENU, tap **ANALYSIS > CURSOR**, or press **CURSOR**.
2. Tap **Mode**, or press the soft key to select **ON**.
3. Tap **Type**, or press the soft key to select **Degree**.

The image shows two screenshots of the CURSOR Degree menu. The first screenshot is the main menu with the following settings and annotations:

- Mode**: OFF ON — Turns cursor measurement on or off
- Type**: Degree — Set the cursor type to Degree.
- Trace**: CH1 — Set the measurement source waveform (OFF, CH1 to CH16, 16CH TEMP/VOLT, CAN, CAN FD, LIN, SENT, Math1 to Math8).
- Cursor1**: 4.000div — Set the cursor positions.
- Cursor2**: 4.000div — Set the cursor positions.
- Reference**: 2.000div — Set the reference cursor position.
- Reference**: 2.000div — Set the reference cursor position.
- Item Setup**: — See “Setting Measurement Items.”
- Other Setup**: — Other settings →

The second screenshot is the **Other Setup** sub-menu with the following settings and annotations:

- RefValue**: 360 — Set the reference angle (1-720). (Angle between the reference cursors (R1, R2))
- Cursor Read Mode**: Display ACQ — See “Cursor Value Read Mode.”
- Brightness**: 8 — Set the cursor display intensity.

Setting Measurement Items (Item Setup)

4. Tap **Item Setup**, or press the soft key. The following screen appears.

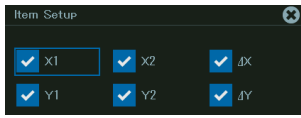

Select the measurement items that you want to use.

X1: Time value at Cursor1

X2: Time value at Cursor2

Δ X: Difference between the time values of Cursor1 and Cursor2

Y1: Vertical value at the intersection of Cursor1 and the waveform

Y2: Vertical value at the intersection of Cursor2 and the waveform

Δ Y: Difference in the vertical values at the intersection of
Cursor1/Cursor2 and the waveform

Cursor Value Read Mode

4. Tap **Other Setup**, or press the soft key.

5. Tap **Cursor Read Mode**, or press the soft key to set the marker value read mode.

The two modes available for reading Y1 and Y2 measurements are Display (display data) or ACQ (acquisition data).

Display: The screen is divided into 1001 parts, and the maximum and minimum values displayed on those rasters are read.

ACQ: Measurement data acquired at the sample rate of each waveform is read. When all traces are selected, measurement data acquired at the sample rate calculated from T/div and record length is read.

10.5 Measuring with Horizontal and Vertical Cursors (H & V)

This section explains the following settings for measuring T-Y waveforms with horizontal and vertical cursors:

For information on cursor measurement on X-Y waveforms, see chapter 6.3.

Items Common to Scope Mode and Recorder Mode

- Turning the cursors on and off
- Cursor type
- Source waveform
- Vertical cursor position
- Horizontal cursor position
- Measurement items
- Measurement source window

► [“Horizontal and Vertical Cursors \(H & V\)” in the Features Guide](#)

CURSOR H & V menu

1. On the waveform screen’s MENU, tap **ANALYSIS > CURSOR**, or press **CURSOR**.
2. Tap **Mode**, or press the soft key to select **ON**.
3. Tap **Type**, or press the soft key to select **H & V**.

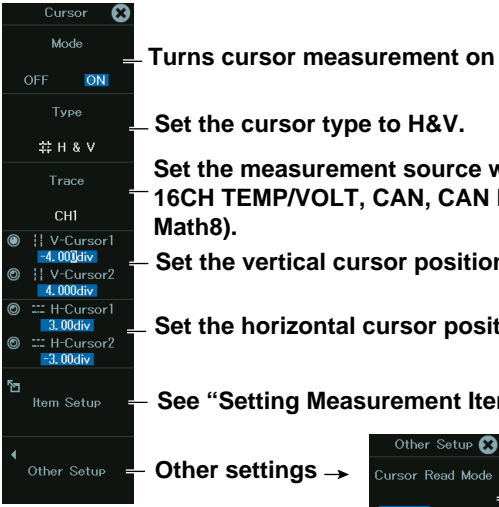

The image shows two screenshots of the CURSOR H & V menu. The first screenshot is the main menu with the following items and annotations:

- Mode**: Turns cursor measurement on or off. The menu shows OFF and ON (selected).
- Type**: Set the cursor type to H&V. The menu shows H & V (selected).
- Trace**: Set the measurement source waveform (OFF, CH1 to CH16, 16CH TEMP/VOLT, CAN, CAN FD, LIN, SENT, Math1 to Math8). The menu shows CH1 (selected).
- V-Cursor1**: Set the vertical cursor positions. The menu shows -4.000div.
- V-Cursor2**: Set the vertical cursor positions. The menu shows 4.000div.
- H-Cursor1**: Set the horizontal cursor positions. The menu shows 3.000div.
- H-Cursor2**: Set the horizontal cursor positions. The menu shows 3.000div.
- Item Setup**: See “Setting Measurement Items.”
- Other Setup**: Other settings →

The second screenshot is the **Other Setup** menu with the following items and annotations:

- Cursor Read Mode**: See “Cursor Value Read Mode.” The menu shows Display (selected) and ACQ.
- Brightness**: Set the cursor display intensity. The menu shows a slider set to 3.

Setting Measurement Items (Item Setup)

4. Tap **Item Setup**, or press the soft key. The following screen appears.

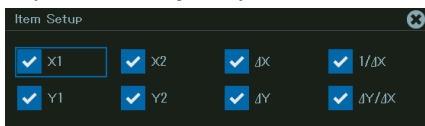

- Select the measurement items that you want to use.
- X1: Time value at V-Cursor1
 - X2: Time value at V-Cursor2
 - ΔX: Difference between the time values of V-Cursor1 and V-Cursor2
 - 1/ΔX: Reciprocal of the difference between the time values of V-Cursor1 and V-Cursor2
 - Y1: Vertical value of H-Cursor1
 - Y2: Vertical value of H-Cursor2
 - ΔY: Difference between the vertical values of H-Cursor1 and H-Cursor2
 - ΔY/ΔX: The amount of change in the vertical value per unit time in the cursor range

Cursor Value Read Mode

4. Tap **Other Setup**, or press the soft key.
5. Tap **Cursor Read Mode**, or press the soft key to set the marker value read mode. The two modes available for reading Y1 and Y2 measurements are Display (display data) or ACQ (acquisition data).

Display: The screen is divided into 1001 parts, and the maximum and minimum values displayed on those rasters are read.

ACQ: Measurement data acquired at the sample rate of each waveform is read. When all traces are selected, measurement data acquired at the sample rate calculated from T/div and record length is read.

Chapter 11

Automated Measurement of Waveform Parameters

Main Control Areas Used in This Chapter

You can also use the touch panel.

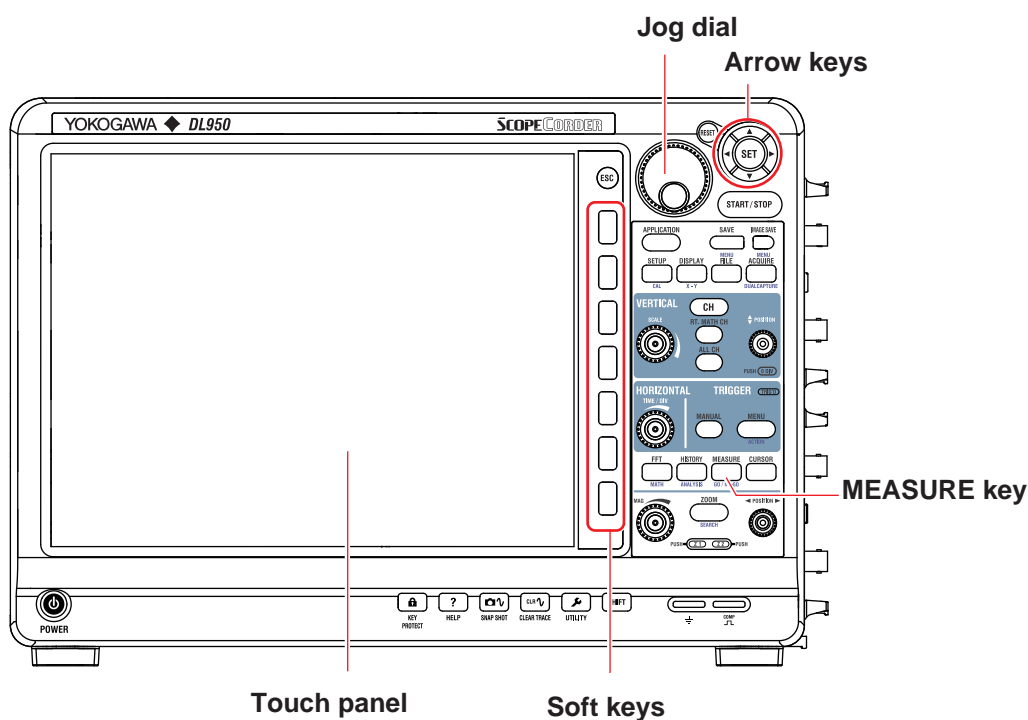

Operation Modes Applicable to the Sections in This Chapter

✓: Applicable, -: Not applicable

Section	Scope Mode	Recorder Mode
11.1 Automatically Measuring Waveform Parameters	✓	✓
11.2 Performing Continuous Statistical Processing	✓	-
11.3 Performing Cyclic Statistical Processing	✓	✓
11.4 Performing Statistical Processing on History Waveforms (Scope mode)	✓	-

* The settings may vary depending on the operation mode.

11.1 Automatically Measuring Waveform Parameters

This section explains the following settings for automatically measuring waveform parameters:

Items Common to Scope Mode and Recorder Mode

- Turning automated measurement on and off
- Source waveform and measurement items
- Delay settings
- Turning period measurement on and off
- Time measurement reference level
- Measurement window and measurement time period

▶ [“Automated Measurement of Waveform Parameters” in the Features Guide](#)

MEASURE Menu

1. On the waveform screen’s MENU, tap **ANALYSIS > MEASURE**, or press **MEASURE**.

When Dual Capture Mode Is Off

— Turns automated measurement on or off

— See “Setting the Source Waveform and Measurement Items.”

— Set the measurement time period.

— See “Setting the Time Measurement Reference Level and 1-Cycle Mode.”

— Set statistical processing to OFF.
Continuous ▶ sec.11.2. Cycle ▶ sec. 11.3. History ▶ sec. 11.4.

— See “Setting the Indicator.”

— See “Setting Measurement Time Period 2.”

When Dual Capture Mode Is On

— See “During Dual Capture.”

Setting the Source Waveform and Measurement Items (Measure Setup)

2. Tap **Measure Setup**, or press the soft key. The following menu appears.

When the source waveform is other than logic or XY

Set the source waveform.*
(Slide to display waveforms that do not fit in the screen.)

Unselects all measurement items
See “Copying to Specified Channels.”

Set measurement items.

Set the source waveform.*
(Slide to display waveforms that do not fit in the screen.)

See “Setting the Delay.”

Clears the settings of all waveforms

When the source waveform is logic

When the source waveform is XY (XY1 to XY8)

* Depending on the channel you select, you need to select sub channels and bits.

Copying to Specified Channels (Copy to)

3. Tap **Copy to**, or select **Copy to** using the jog dial or arrow keys, and press **SET**. The following screen appears.

Copying is not possible when the copy source waveform is an XY waveform.

Copy to

Source Channel: CH1

<input type="checkbox"/> CH1	<input checked="" type="checkbox"/> CH2	<input checked="" type="checkbox"/> CH3_1	<input checked="" type="checkbox"/> CH3_2
<input checked="" type="checkbox"/> CH3_3	<input checked="" type="checkbox"/> CH3_4	<input checked="" type="checkbox"/> CH3_5	<input checked="" type="checkbox"/> CH3_6
<input checked="" type="checkbox"/> CH3_7	<input checked="" type="checkbox"/> CH3_8	<input checked="" type="checkbox"/> CH3_9	<input checked="" type="checkbox"/> CH3_10
<input checked="" type="checkbox"/> CH3_11	<input checked="" type="checkbox"/> CH3_12	<input checked="" type="checkbox"/> CH3_13	<input checked="" type="checkbox"/> CH3_14
<input checked="" type="checkbox"/> CH3_15	<input checked="" type="checkbox"/> CH3_16	<input checked="" type="checkbox"/> CH5	<input checked="" type="checkbox"/> CH6
<input checked="" type="checkbox"/> CH9_F1	<input checked="" type="checkbox"/> CH9_F2	<input checked="" type="checkbox"/> CH9_F3	<input checked="" type="checkbox"/> CH9_S1
<input checked="" type="checkbox"/> CH9_S2	<input checked="" type="checkbox"/> CH9_S3	<input checked="" type="checkbox"/> CH9_S4	<input type="checkbox"/> CH9_S5
<input checked="" type="checkbox"/> CH9_EC	<input checked="" type="checkbox"/> CH10_F1	<input type="checkbox"/> CH10_F2	<input type="checkbox"/> CH10_F3

Buttons: All ON, All OFF, Execute

Annotations:

- Copy source channel
- Select the channels that you want to copy to. (Slide to display waveforms that do not fit in the screen.)
- Clears all selected channels
- Selects all channels
- Starts copying

Setting the Delay

3. Tap **Delay**, or select **Delay** using the jog dial or arrow keys, and press **SET**. The following screen appears.

Delay Setup

Trace: CH9

Mode: Time / Degree

Polarity: F / Z

Edge Count: 1

Reference Trace: Trace / Trigger

Reference Trace: CH2

Reference Trace: Mode: Time / Degree

Reference Trace: Polarity: F / Z

Reference Trace: Edge Count: 1

Annotations:

- Set the delay value unit (Time, Degree).
- Set the slope of the edge to be detected.
- Set which counted edge to use as a detected point.
- Set the delay measurement reference.
- Set the reference waveform conditions. (only when Reference is set to Trace)
- Set the reference waveform.* (Slide to display waveforms that do not fit in the screen.)
- Set the slope of the edge to be detected.
- Set which counted edge to use as a detected point.

* Depending on the channel you select, you need to select sub channels and bits.

Setting the Measurement Time Period (Time Range1/Time Range2)

The specified parameters are measured in the range between the measurement start point (Time Range1) and measurement end point (Time Range2).

Note

For SSD recording waveforms, up to 100 Mpoint from the measurement start point (Time Range1) are measured.

Setting the Time Measurement Reference Level and 1-Cycle Mode (Detail)

2. Tap **Detail**, or press the soft key. The following menu appears.

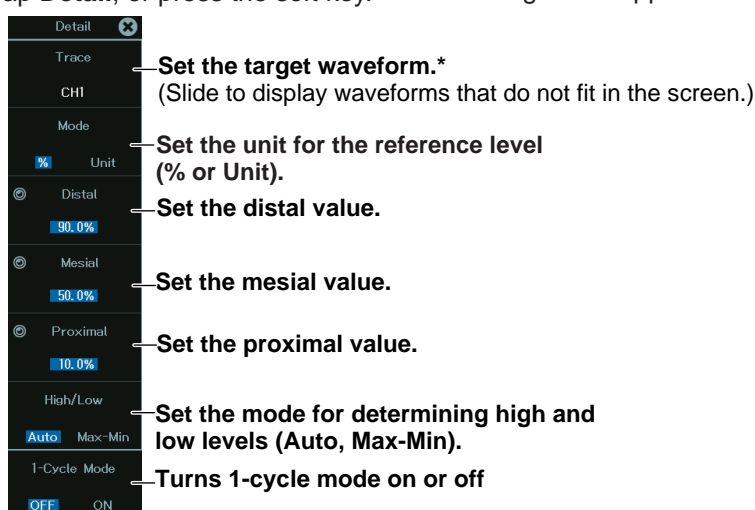

* Depending on the channel you select, you need to select sub channels and bits.

Note

When 1-cycle mode is on, if the interval between Time Range1 and Time Range2 is less than 1 cycle, the measured value will be "*****."

Setting the Indicator (Indicator)

The measurement area of the specified item is displayed with cursors.

2. Tap **Indicator**, or press the soft key. The following menu appears.

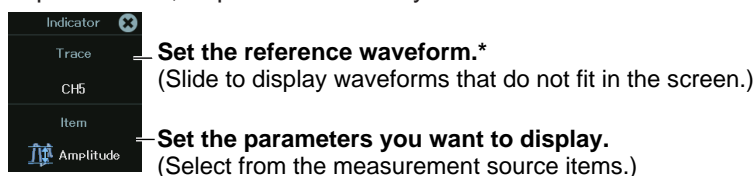

* Depending on the channel you select, you need to select sub channels and bits.

The measurement areas of the following items can be indicated.

Peak to Peak, Amplitude, Maximum, Minimum, High, Low, Average, Middle, RMS, Std, Deviation, +Overshoot, -Overshoot, Rise, Fall, Frequency, Period, +Width, -Width, Duty, Burst1, Burst2, Avg Frequency, Avg Period, Integ1TY+, Integ2TY, Delay

Setting Measurement Time Period 2 (Area2 Mode)

Set this to simultaneously measure parameters in two areas.

2. Tap **Area2 Mode**, or press the soft key. The following menu appears.

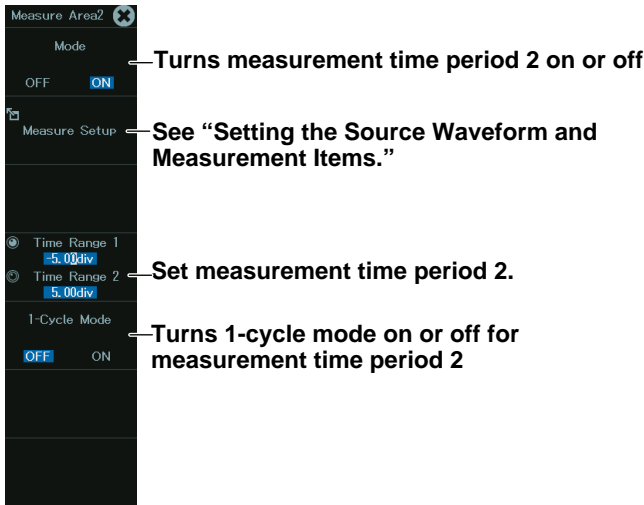

During Dual Capture

When measuring in dual capture mode, set the measurement time period, measurement items, and 1-cycle mode separately for high-speed sampling and low-speed sampling.

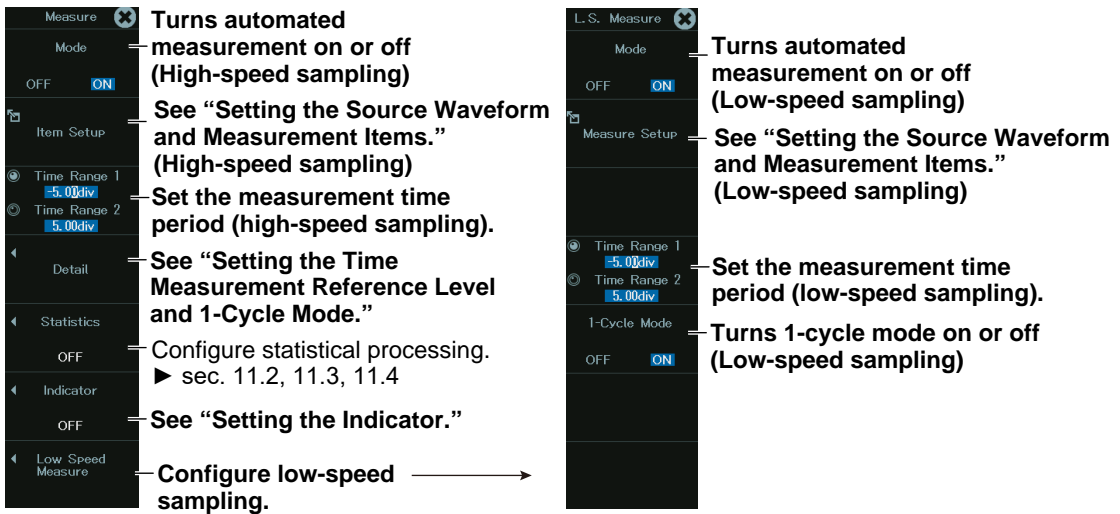

11.2 Performing Continuous Statistical Processing

This section explains the following setting for performing continuous statistical processing on the displayed waveforms:

Items Common to Scope Mode and Recorder Mode

- Turning statistical processing on
 - ▶ “[Continuous Statistical Processing \(Continuous\)](#)” in the [Features Guide](#)

MEASURE Statistics Menu

1. On the waveform screen’s MENU, tap **ANALYSIS** > **MEASURE**, or press **MEASURE**.
2. Tap **Statistics**, or press the soft key. The following screen appears.

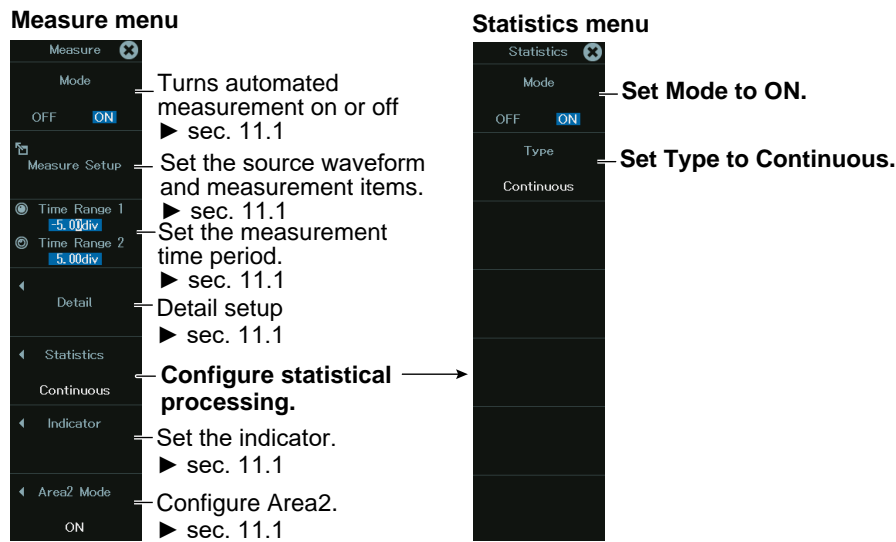

11.3 Performing Cyclic Statistical Processing

This section explains the following settings for performing cycle statistic processing on the displayed waveforms):

Items Common to Scope Mode and Recorder Mode

- Turning cycle statistics on
- Source waveform used to determine the cycle
- Displaying results

► [“Cyclic Statistical Processing \(Cycle\)” in the Features Guide](#)

MEASURE Statistics Menu

1. On the waveform screen’s MENU, tap **ANALYSIS > MEASURE**, or press **MEASURE**.
2. Tap **Statistics**, or press the soft key. The following screen appears.

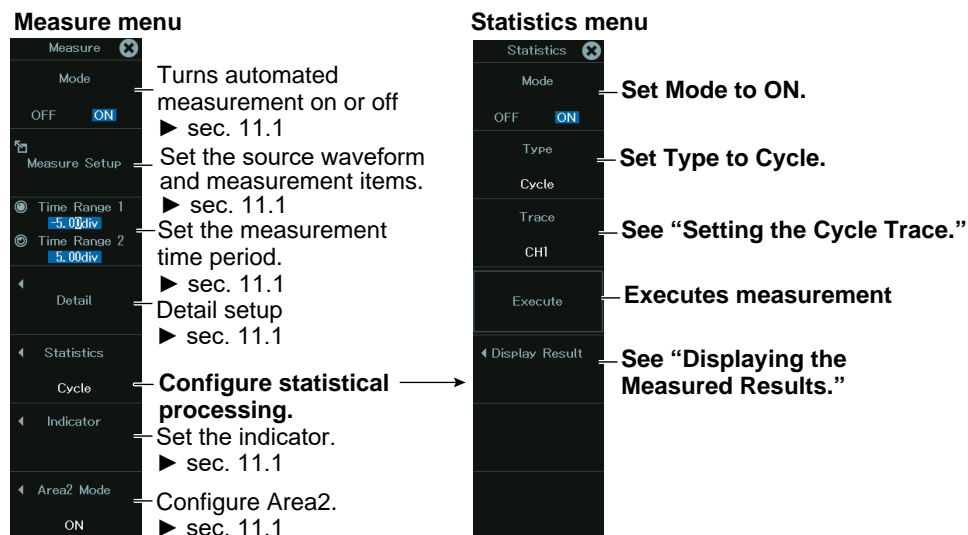

Setting the Cycle Trace (Trace)

3. Tap **Trace**, or press the soft key. Select the cycle trace from the following.

Depending on the channel you select, you need to select sub channels and bits.

- Own:

The instrument determines the period of each source waveform. It then automatically measures the waveform parameters and performs statistical processing once per period. However, if signals that have different periods are applied to multiple channels, the number of iterations of automated measurement and statistical processing for each signal is equal to the number of periods in the slowest signal.

- CH1 to CH16, 16CH TEMP/VOLT, CAN, CAN FD, LIN, SENT, Math1 to Math8, FFT1 to FFT8:

The instrument automatically measures the waveform parameters of all the source waveforms and performs statistical processing on the measured values for each cycle of the specified channel.

Displaying the Measured Results (Display Result)

3. Tap **Display Result**, or press the soft key. The following screen appears.

↑: Displayed next to the maximum value of each measurement item.
 ↓: Displayed next to the minimum value of each measurement item.

	P-P(CH1)	Amp(CH1)	High(CH1)	Low(CH1)
1	xxxxx	xxxxx	xxxxx	xxxxx
2	xxxxx	xxxxx	xxxxx	xxxxx
3	xxxxx	xxxxx	xxxxx	xxxxx
4	xxxxx	xxxxx	xxxxx	xxxxx
5	xxxxx	xxxxx	xxxxx	xxxxx
6	xxxxx	xxxxx	xxxxx	xxxxx
7	xxxxx	xxxxx	xxxxx	xxxxx
8	xxxxx	xxxxx	xxxxx	xxxxx
9	xxxxx	xxxxx	xxxxx	xxxxx
10	xxxxx	xxxxx	xxxxx	xxxxx
11	xxxxx	xxxxx	xxxxx	xxxxx
12	xxxxx	xxxxx	xxxxx	xxxxx
13	xxxxx	xxxxx	xxxxx	xxxxx
14	xxxxx	xxxxx	xxxxx	xxxxx

Sort
 Forward
 Sorts the display (Forward, Reverse)

Statistics Max
 Displays the maximum value

Statistics Min
 Displays the minimum value

When this scroll bar is displayed, you can drag the screen or use the left and right arrow keys to scroll the display.

11.4 Performing Statistical Processing on History Waveforms (Scope mode)

This section explains the following settings for performing statistical processing on history waveforms:

Scope Mode

- Turning history waveform statistics on
- Displaying results
 - ▶ “Statistical Processing of History Waveforms (History)” in the Features Guide

MEASURE Statistics Menu

1. On the waveform screen's MENU, tap **ANALYSIS** > **MEASURE**, or press **Measure**.
2. Tap **Statistics**, or press the soft key. The following screen appears.

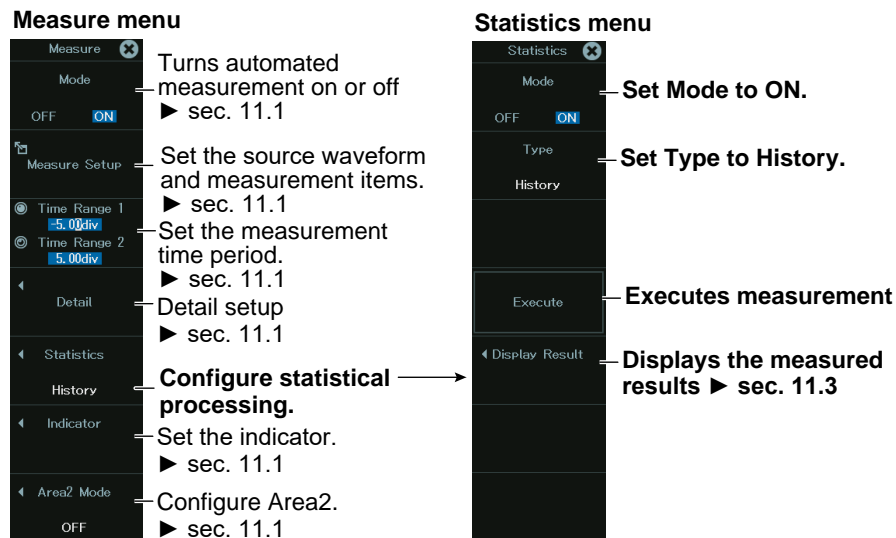

Chapter 12

FFT

Main Control Areas Used in This Chapter

You can also use the touch panel.

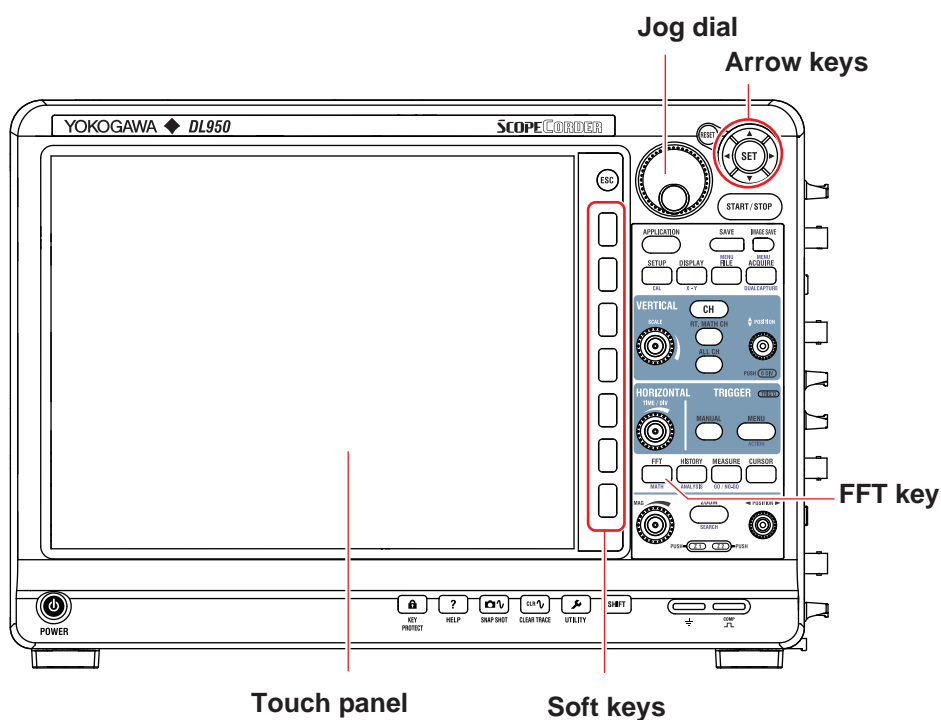

Operation Modes Applicable to the Sections in This Chapter

✓: Applicable, -: Not applicable

Section	Scope Mode	Recorder Mode
12.1 Displaying FFT Waveforms	✓	✓
12.2 Setting the Details of the FFT	✓	✓
12.3 Measuring FFT Waveforms with Cursors	✓	✓

* The settings may vary depending on the operation mode.

12.1 Displaying FFT Waveforms

This section explains the following FFT waveform display settings:

Items Common to Scope Mode and Recorder Mode

- Turning the window for displaying FFT waveforms on and off
- Main waveform display area ratio
- FFT window layout
- Turning FFT window linking on and off
- Window1 and Window2 display settings

► “Display Ratio of the Main Window (Main Ratio),”
“Window Layout (Window Layout),”
“Combine Display (Combine Display),” and
“Window Display Setup (Window Display Setup)” in the Features Guide

FFT Menu

1. On the waveform screen’s MENU, tap **ANALYSIS > FFT**, or press **FFT**. The following screen appears.

FFT menu (1/2)

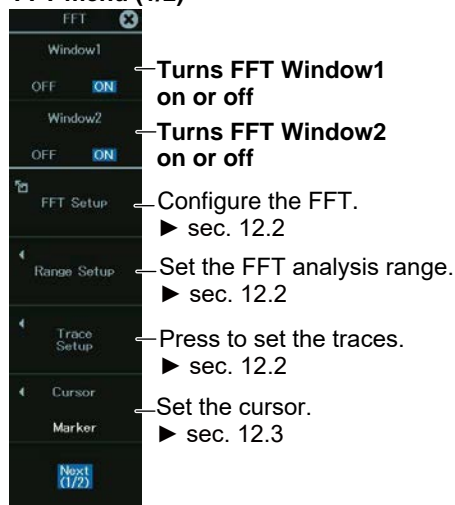

FFT menu (2/2)

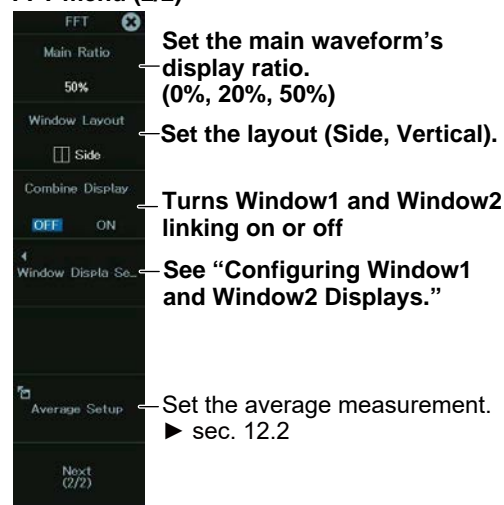

Configuring Window1 and Window2 Displays

2. On the FFT menu (2/2), tap **Window Display Setup**, or press the soft key. The following screen appears.

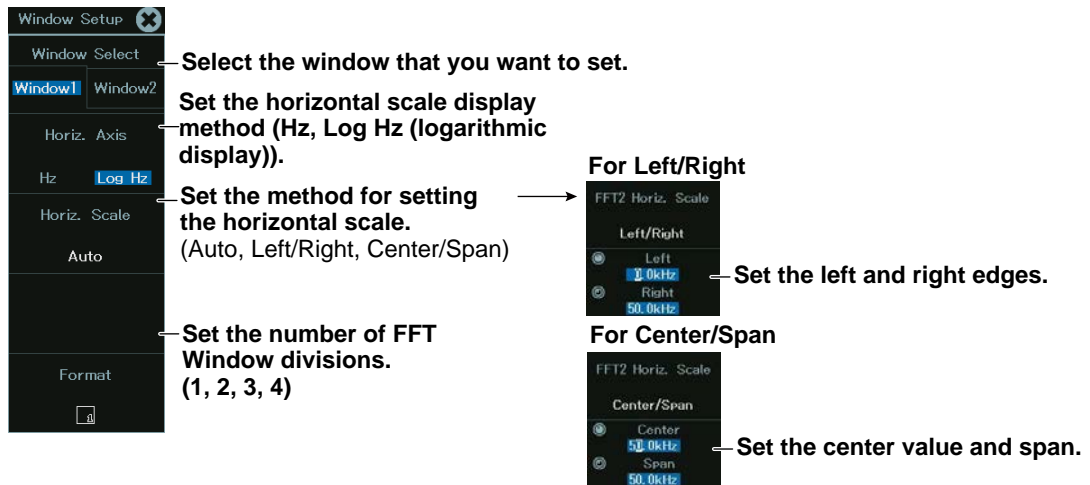

Waveforms Displayed in Window1 and Window2

Window1 displays the waveforms that are turned on from FFT1 to FFT4, and Window2 displays the waveforms that are turned on from FFT5 to FFT8.

When the window is divided, FFT waveforms are assigned in ascending order by number from the top area. When a waveform is assigned to the bottom area, subsequent waveforms are assigned again in order from the top area.

For the FFT1 to FFT8 settings, see section 12.2.

12.2 Setting the Details of the FFT

This section explains the detail settings of FFT waveforms.

Items Common to Scope Mode and Recorder Mode

- FFT start point and number of FFT points
- Window function
- Spectrum type and sub type
- Source waveform
- Setting the vertical scale (center value, minimum unit)
- Setting the average measurement

► “All Math Setup (FFT Setup),”
“Math Range Setup (Range Setup),”
“FFT Trace Setup (Trace Setup),”
“FFT Math Setup (FFT Math Setup),” and
“Average Setup (Average Setup)/(G02 option)” in the Features Guide

FFT Menu

1. On the waveform screen’s MENU, tap **ANALYSIS** > **FFT**, or press **FFT**. The following screen appears.

FFT menu (1/2)

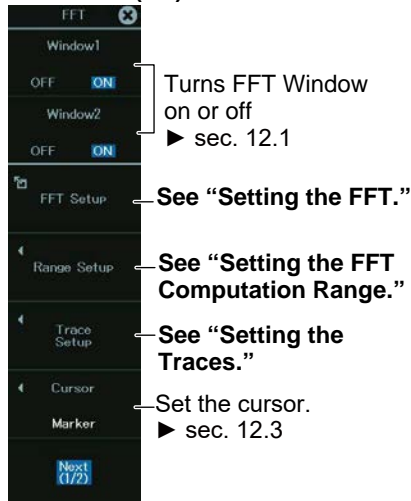

FFT menu (2/2)

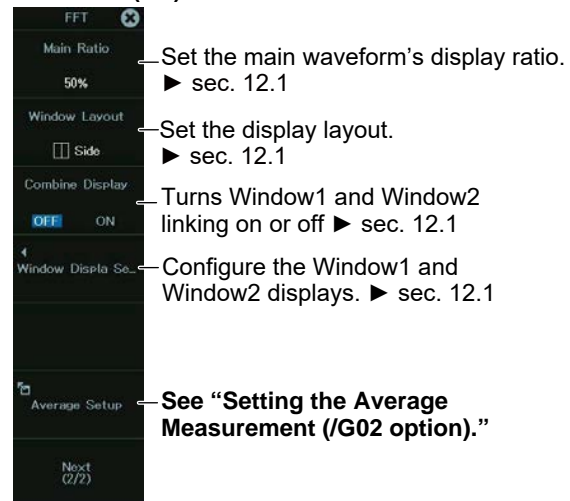

Setting the FFT (FFT Setup)

2. On the FFT menu (1/2), tap **FFT Setup**, or press the soft key. The following screen appears.

Configure FFT Window1. **Configure FFT Window2.**

Turns FFT Window1 and 2 on or off¹
 FFT start point²
 Number of FFT points² (1k, 2k, 5k, 10k, 20k, 50k, 100k)
 Set the window function.³ (Rect, Hanning, FlatTop, Hamming, Exponential)

	Mode	Type	Sub Type	Source1	Source2		Mode	Type	Sub Type	Source1	Source2
FFT1	ON	PS	LOGMAG	CH1	-	FFT5	ON	PS	LOGMAG	CH7	-
FFT2	ON	PS	LOGMAG	CH3_1	-	FFT6	OFF	PS	LOGMAG	CH8	-
FFT3	ON	PS	LOGMAG	CH1	-	FFT7	ON	PS	LOGMAG	CH10	-
FFT4	ON	PS	LOGMAG	CH7	-	FFT8	ON	PS	LOGMAG	CH11	-

Set source waveform 2.⁴ (Needs to be set depending on the spectrum type)
 Set the source waveform.⁴
 Set the spectrum sub type⁴ (REAL, IMAG, MAG, LOGMAG, PHASE).
 Set the spectrum type⁴ (LS, RS, PS, PSD, CS, TF, or CH).

Turns FFT on or off.⁴

- 1: Same as the Window1 and Window2 on/off setting in section 12.1
- 2: Same as the FFT analysis range setting
- 3: Same as the window function setting of average measurement
- 4: Same as the trace setting

Note

If the number of points is set to 50 k, you cannot display FFT1, FFT2, FFT5, or FFT6.
 If the number of points is set to 100 k, you can only display FFT1 and FFT5.

Setting the Exponential Window Function (/G02 option)

When the window function is set to Exponential, use the Setup button to set the damping rate and measurement time period.

Set the damping rate.
 Set the math range.

Setting the FFT Computation Range (Range Setup)

- On the FFT menu (1/2), tap **Range Setup**, or press the soft key. The following screen appears.

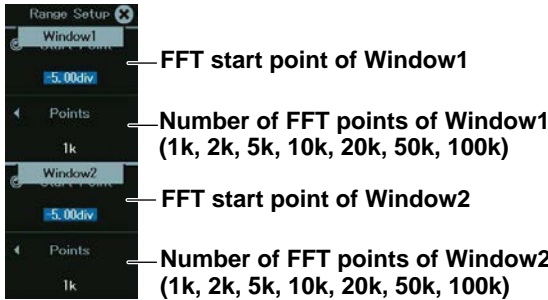

The FFT start point and the number of FFT points are the same as those explained in “Setting the FFT.”

Setting the Traces (Trace Setup)

- On the FFT menu (1/2), tap **Trace Setup**, or press the soft key. The following screen appears.

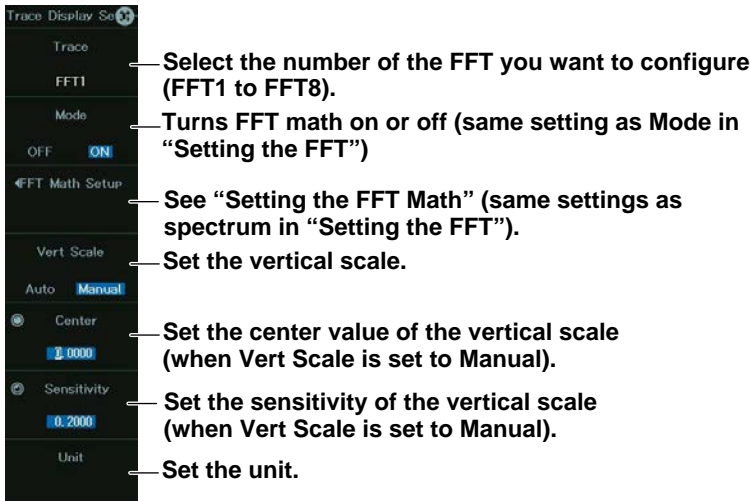

Setting the FFT Math (FFT Math Setup)

- Tap **FFT Math Setup**, or press the soft key. The following screen appears.

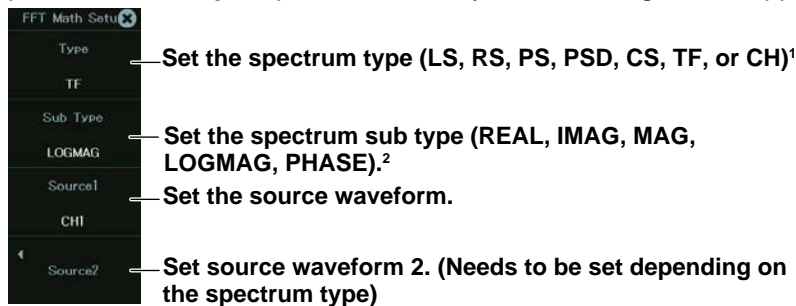

1: Fixed to PS when the /G02 option is not installed.

2: Fixed to LOGMAG when the /G02 option is not installed.

The FFT math settings are the same as the spectrum type, sub type, and source waveform settings explained in “Setting the FFT.”

Setting the Average Measurement (Average Setup) (/G02 option)

- On the FFT menu (2/2), tap **Average Setup**, or press the soft key. The following screen appears.

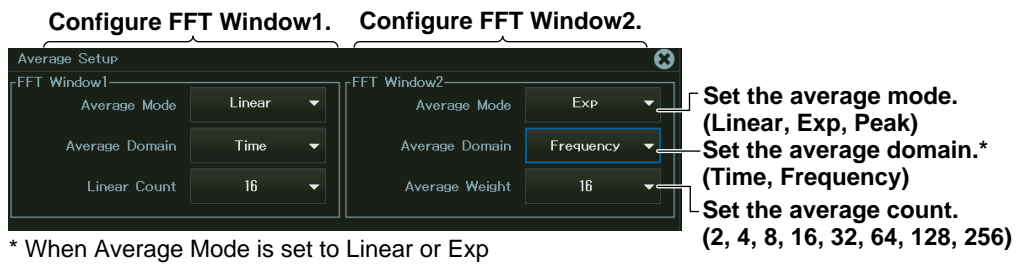

12.3 Measuring FFT Waveforms with Cursors

This section explains cursor measurements of FFT waveforms.

Items Common to Scope Mode and Recorder Mode

- Turning the cursors on and off
- Cursor type

Marker cursor

- Source waveform
- Marker position
- Marker form
- Measurement items

Peak cursor

- Measurement time period
- Measurement items

▶ [“Maker Cursor \(Maker\)” and “Peak Cursor \(Peak\)” in the Features Guide](#)

FFT Menu

1. On the waveform screen’s MENU, tap **ANALYSIS > FFT**, or press **FFT**. The following screen appears.

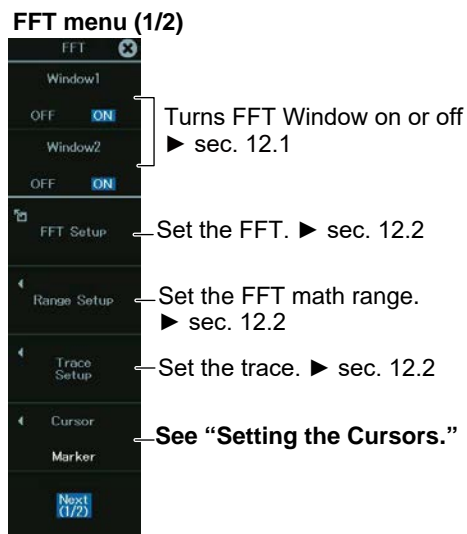

Setting the Cursors (Cursor)

2. On the FFT menu (1/2), tap **Cursor**, or press the soft key.

Measuring with Marker Cursors (Marker)

3. Tap **Type**, or press the soft key to select **Marker**.

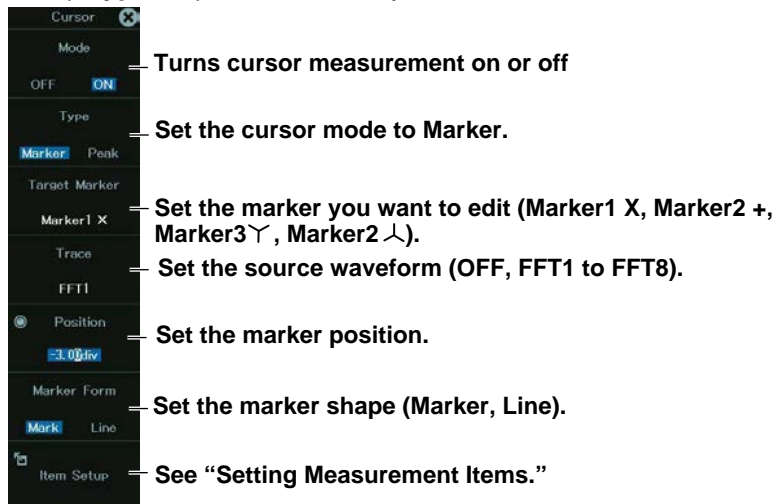

Setting Measurement Items (Item Setup)

4. Tap **Item Setup**, or press the soft key. The following screen appears.

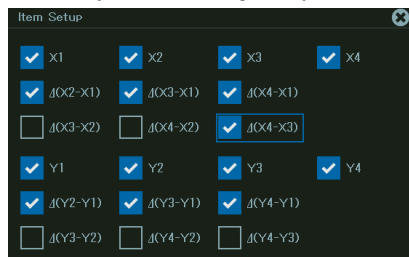

Select the measurement items that you want to use.

X1	Frequency of Marker1
X2	Frequency of Marker2
X3	Frequency of Marker3
X4	Frequency of Marker4
Δ(X2-X1)	Frequency difference between Marker1 and Marker2
Δ(X3-X1)	Frequency difference between Marker1 and Marker3
Δ(X4-X1)	Frequency difference between Marker1 and Marker4
Δ(X3-X2)	Frequency difference between Marker2 and Marker3
Δ(X4-X2)	Frequency difference between Marker2 and Marker4
Δ(X4-X3)	Frequency difference between Marker3 and Marker4
Y1	Vertical value at Marker1
Y2	Vertical value at Marker2
Y3	Vertical value at Marker3
Y4	Vertical value at Marker4
Δ(Y2-Y1)	Difference between the vertical values of Marker1 and Marker2
Δ(Y3-Y1)	Difference between the vertical values of Marker1 and Marker3
Δ(Y4-Y1)	Difference between the vertical values of Marker1 and Marker4
Δ(Y3-Y2)	Difference between the vertical values of Marker2 and Marker3
Δ(Y4-Y2)	Difference between the vertical values of Marker2 and Marker4
Δ(Y4-Y3)	Difference between the vertical values of Marker3 and Marker4

Measuring with Peak Cursors (Peak)

3. Tap **Type**, or press the soft key to select **Peak**.

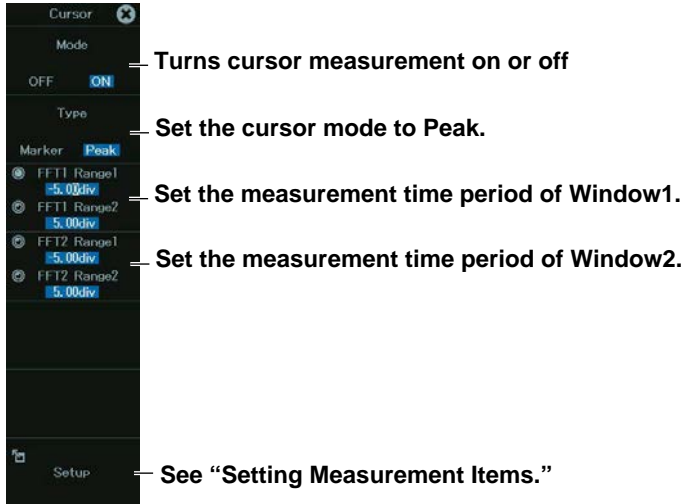

Setting Measurement Items (Setup)

4. Tap **Setup**, or press the soft key. The following screen appears.

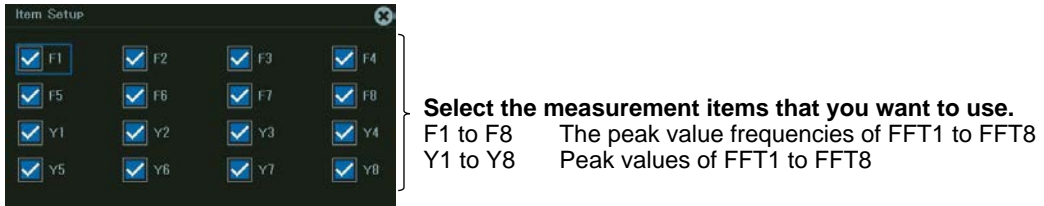

Chapter 13

Math

Main Control Areas Used in This Chapter

You can also use the touch panel.

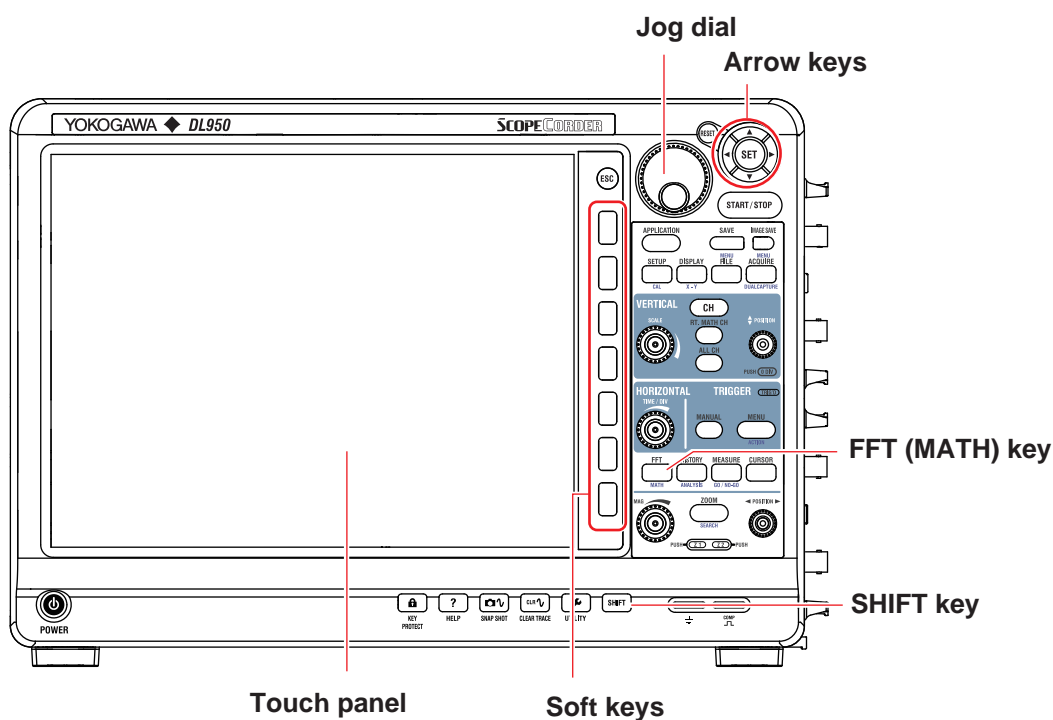

Operation Modes Applicable to the Sections in This Chapter

✓: Applicable, -: Not applicable

Section	Scope Mode	Recorder Mode
13.1 Setting Expressions and Computation Ranges	✓	✓
13.2 Setting the Math Waveform Scaling	✓	✓
13.3 Setting Averaging (/G02 Option)	✓	✓
13.4 Performing User-Defined Math (/G02 option)	✓	✓

* The settings may vary depending on the operation mode.

13.1 Setting Expressions and Computation Ranges

This section explains the following settings for setting expressions:

Items Common to Scope Mode and Recorder Mode

- Math waveform to edit
- Turning computation on and off
- Setting expressions (operator, function, computation source waveform, unit, label, settings for specific operators and functions)
- Setting the computation range

► “Math” in the Features Guide

Math Menu

1. On the waveform screen’s MENU, tap **ANALYSIS > MATH**, or press **SHIFT+FFT (MATH)**. The Math menu appears.

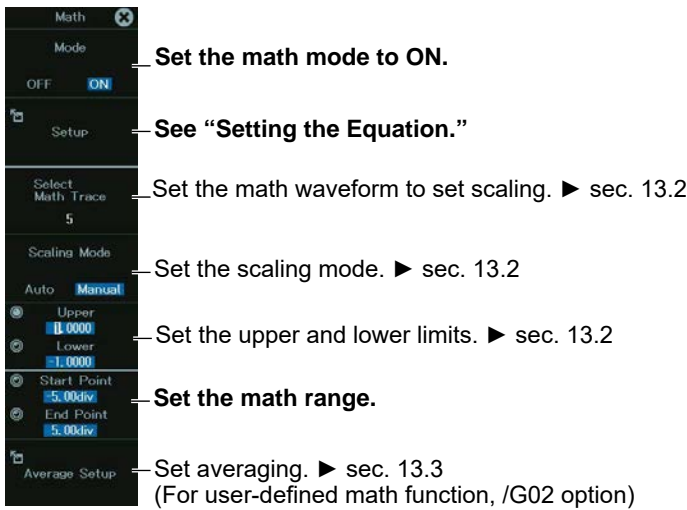

Setting the Expression (Setup)

2. Tap **Setup**, or press the soft key.
3. Tap the math number that you want to assign an expression to, or use a jog dial and arrow keys to select the math number, and press **SET**. The following screen appears.

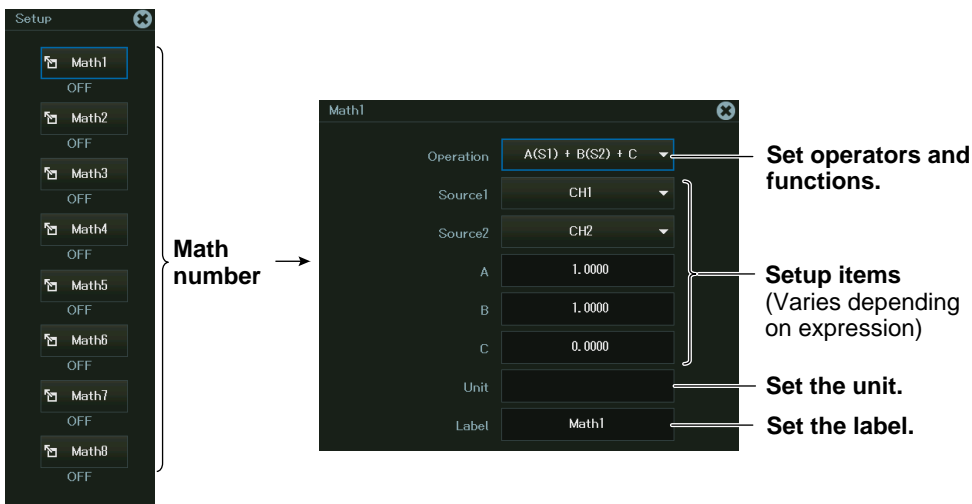

Note

On models with the/G02 option, User Define (user define) is displayed in the expression list. For details on user-defined computation, see section 13.4.

Basic Arithmetic with Coefficients

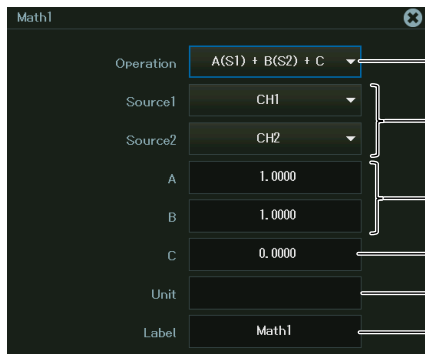

- Select $A(S1)+B(S2)+C$, $A(S1)-B(S2)+C$, $A(S1)*B(S2)+C$, or $A(S1)/B(S2)+C$.
- Math source waveform (channel whose acquisition is set to on, channel (Math1 to Math7)) with a number smaller than the number of the math channel you are setting)
- Scale value
- Offset
- Set the unit.
- Set the label.

Basic arithmetic without coefficients is selected when you set scale value A and B to 1 and offset value C to 0.

Binary Computation

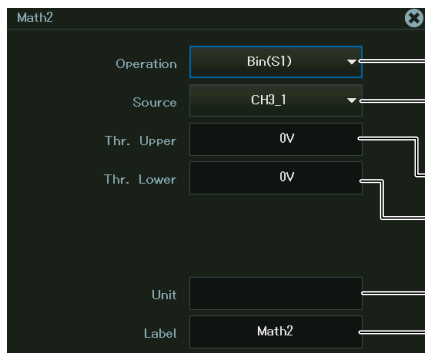

- Select $Bin(S1)$.
- Math source waveform (channel whose acquisition is set to on, channel (Math1 to Math7)) with a number smaller than the number of the math channel you are setting)
- Upper threshold limit
- Lower threshold limit
- Set the unit.
- Set the label.

Phase Shift

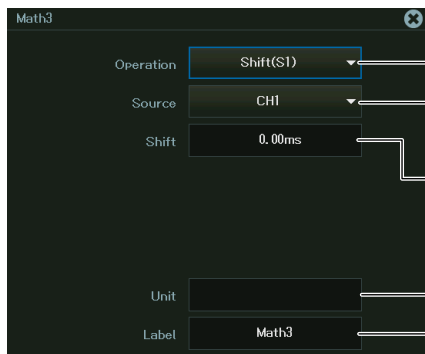

- Select $Shift(S1)$.
- Math source waveform (channel whose acquisition is set to on, channel (Math1 to Math7)) with a number smaller than the number of the math channel you are setting)
- Phase shift amount
- Set the unit.
- Set the label.

13.2 Setting the Math Waveform Scaling

This section explains the following settings for displaying computed waveforms:

Items Common to Scope Mode and Recorder Mode

- Vertical scale

► “Scaling Mode (Scaling)” in the Features Guide

Math Menu

1. On the waveform screen’s MENU, tap **ANALYSIS > MATH**, or press **SHIFT+FFT (MATH)**. The Math menu appears.

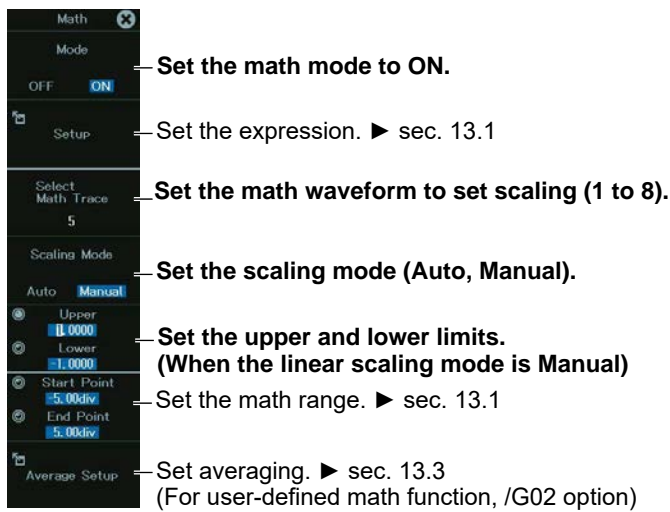

13.3 Setting Averaging (/G02 Option)

This section explains the following averaging settings:

The averaging explained here applies to math waveforms.

Items Common to Scope Mode and Recorder Mode

- Average settings (including peak computation)
 - ▶ “Average Setup (Average Setup)/G02 option)” in the Features Guide

Math Menu

1. On the waveform screen's MENU, tap **ANALYSIS > MATH**, or press **SHIFT+FFT (MATH)**. The Math menu appears.

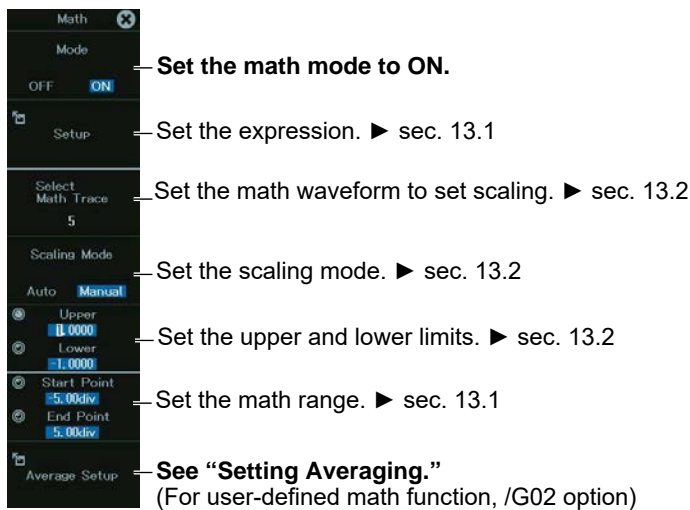

Setting Averaging

2. Tap the **Average Setup** tab, or press the soft key. The following screen appears.

Simple average

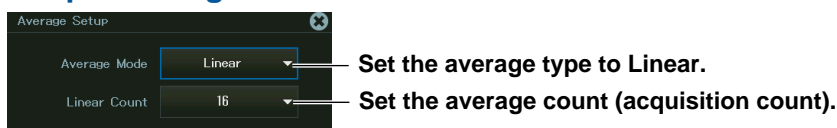

Exponential average



13.3 Setting Averaging (/G02 Option)

Cycle average

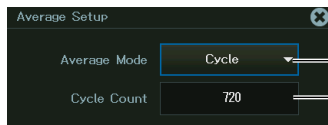

Set the average type to Cycle.

Set the number of data points in one cycle.

Peak computation

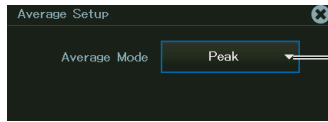

Set the average type to Peak.

13.4 Performing User-Defined Math (/G02 option)

This section explains the following settings for user-defined math:

Items Common to Scope Mode and Recorder Mode

- Setting user-defined math functions
 - ▶ [“User-Defined Math Function \(User Define\)/G02 option”](#) in the [Features Guide](#)

Math Menu

1. On the waveform screen’s MENU, tap **ANALYSIS > MATH**, or press **SHIFT+FFT (MATH)**. The Math menu appears.

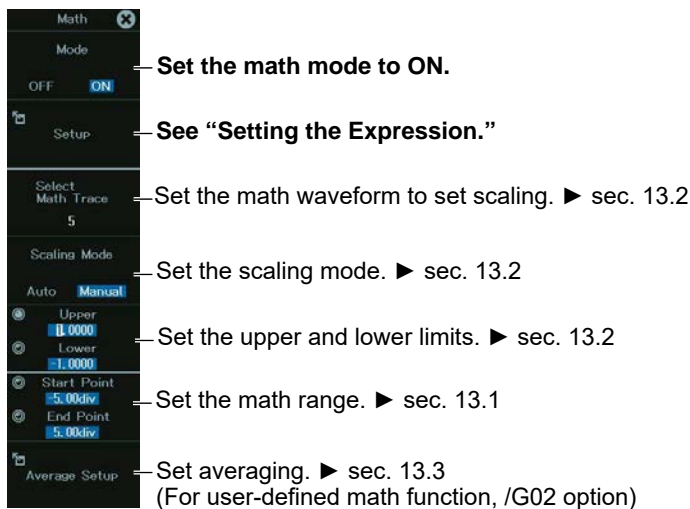

Setting the Expression (Setup)

2. Tap **Setup**, or press the soft key.
3. Tap the math number that you want to assign an expression to, or use a jog dial and arrow keys to select the math number, and press **SET**. The following screen appears.

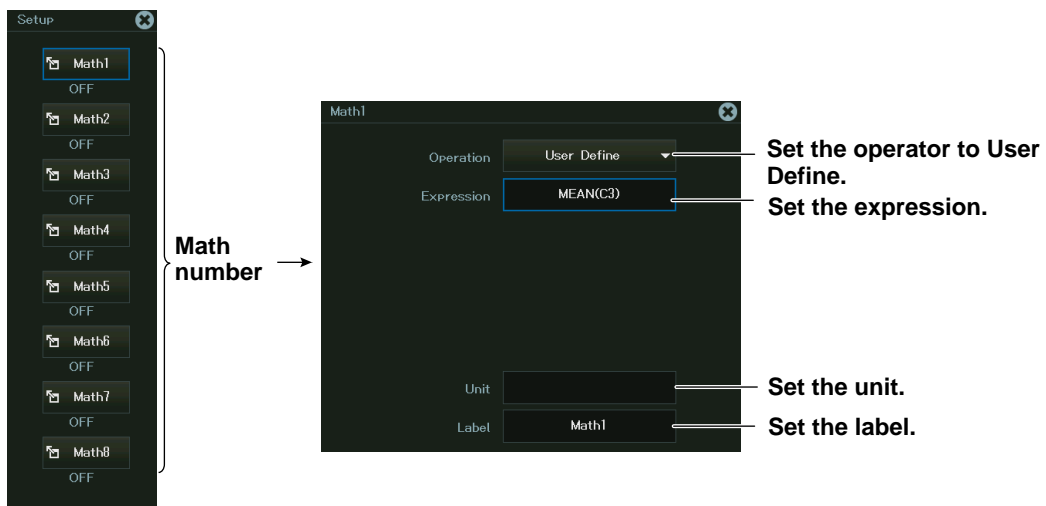

13.4 Performing User-Defined Math (/G02 option)

4. Tap the **Expression** box, or select the Expression box using the jog dial or arrow keys, and press **SET**. The following screen appears.

Set the automated measurement values of waveform parameters to add to the expression.

Set the filters (Filter1, Filter2).

Set constants (K1 to K8).

Setting a Filter (Filter Setup)

5. Tap **Filter Setup**, or select **Filter Setup** using the jog dial or arrow keys, and press **SET**. The following screen appears.

Register as FILT2.

Register as FILT2.

Setting Constants

5. Tap **Constant(K)**, or select **Constant(K)** using the jog dial, and press **SET**. The following screen appears.

Notes on Setting User-Defined Math Functions

When setting a user-defined math function, keep the following in mind.

- A math channel with a larger number cannot be used in an expression of a mass channel with a smaller number.
- An expression with only constants cannot be defined.
- An expression can only contain up to two FILT1 or FILT2 functions.
- Other computations cannot be performed on a pulse width computation.
- When performing shift computation, pulse width computation, or binary conversion, only a single operator can be used in an expression.

For details, see the Features Guide (IM DL950-01EN) contained in the CD.

Chapter 14

GO/NO-GO Determination (Scope mode only)

Main Control Areas Used in This Chapter

You can also use the touch panel.

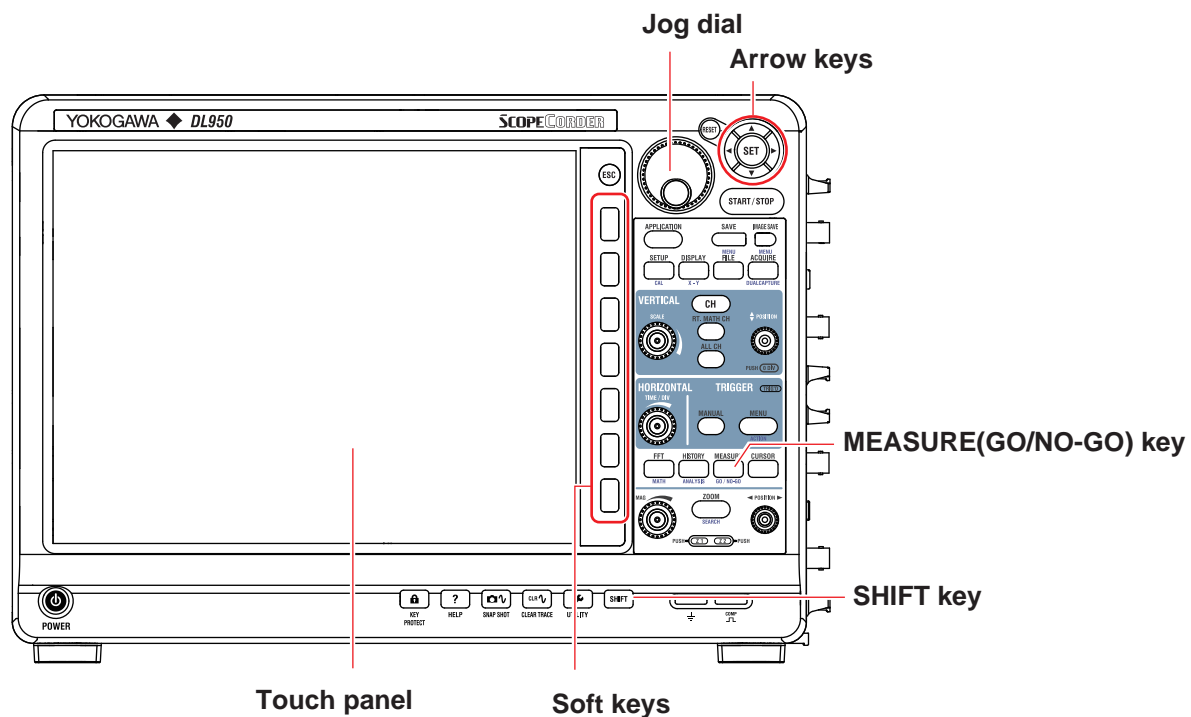

Operation Modes Applicable to the Sections in This Chapter

✓: Applicable, -: Not applicable

Section	Scope Mode	Recorder Mode
14.1 Performing GO/NO-GO Determination with Waveform Zones	✓	-
14.2 Performing GO/NO-GO Determination with Waveform Parameters	✓	-

* The settings may vary depending on the operation mode.

14.1 Performing GO/NO-GO Determination with Waveform Zones

This section explains the following settings for performing GO/NO-GO determination with waveform zones:

Applicable in Scope Mode

- Selecting the mode
- Creating and editing waveform zones
- Judgment conditions
- Setting actions

► [“Waveform Zone \(Wave Zone\)” in the Features Guide](#)

GO/NO-GO Menu

1. On the waveform screen's MENU, tap **ANALYSIS > GO/NOGO**, or press **SHIFT+MEASURE (GO/NO-GO)**. The following screen appears.

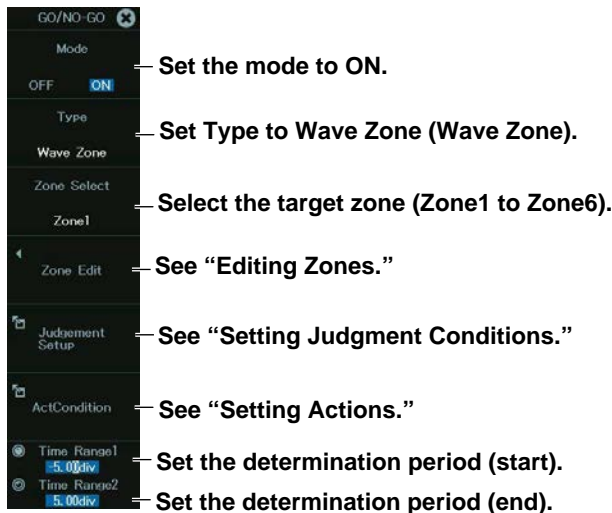

Editing Zones (Edit Zone)

2. Tap **Edit Zone**, or press the soft key. The following screen appears.

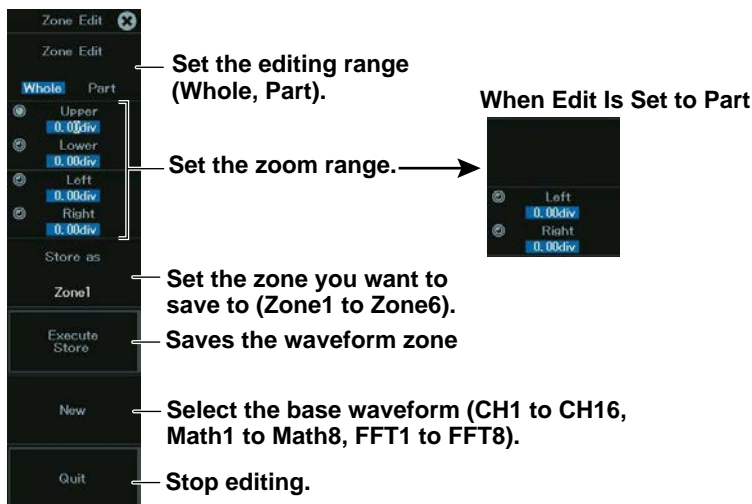

Setting the Judgment Conditions (Judgement Setup)

2. Tap **Judgement Setup**, or press the soft key. The following screen appears.

Set the judgment criterion (X, IN, OUT).

Select the source waveform (CH1 to CH16, Math1 to Math8, FFT1 to FFT8).

Set the zone number (Zone1-Zone6).

#	Mode	Trace	Zone No.
1	IN	CH1	Zone1
2	OUT	CH2	Zone1
3	IN	CH3	Zone1
4	X	CH1	Zone1
5	X	CH1	Zone1
6	X	CH1	Zone1
7	X	CH1	Zone1
8	X	CH1	Zone1

Annotations:

- Logic:** AND (selected), OR
- ActCondition:** Always, Fail (selected), Success
- Sequence:** Single, Continue (selected)
- Acquisition Count:** Infinite
- Remote:** OFF (selected), ON

Additional annotations:

- Scroll bar:** Scroll to display reference conditions that do not fit in the screen.
- Set the determination logic (AND, OR).**
- Set the action condition (Always, Fail, Success).**
- Set the sequence (Single, Continue).**
- Set the number of waveforms to acquire.**
- Turns external start on or off**

Determination Logic (Logic)

AND: The specified action is executed when all the specified judgment conditions are met.

OR: The specified action is executed when any of the specified judgment conditions is met.

Action Condition (Act Condition)

Always: The specified actions is always executed.

Fail: The specified action is executed when the GO conditions are not met.

Success: The specified actions is executed when the GO conditions are met.

Sequence (Sequence)

Single: The specified action is executed once.

Continue: The specified action is executed repeatedly. The specified action is executed until the number of acquisitions specified by ACQ Count is reached. If ACQ Count is set to Infinite, the set actions are executed until waveform acquisition is stopped.

Setting Actions (Action Setup)

2. Tap **Action Setup**, or press the soft key. The following screen appears.

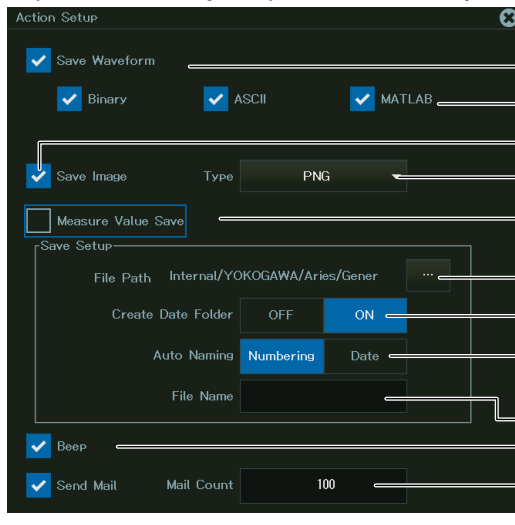

The screenshot shows the 'Action Setup' screen with the following settings and annotations:

- Save Waveform** (checked): Saves the waveform data
- Waveform data format**: Binary (checked), ASCII (checked), MATLAB (checked)
- Save Image** (checked): Saves a screen capture
- Screen capture data format (PNG, BMP, JPEG)**: Type: PNG
- Measure Value Save** (unchecked): Saves waveform parameters measured automatically
- Save Setup** (checked):
 - File Path**: Internal/YOKOGAWA/Aries/Gener ... Set the waveform parameter save destination.
 - Create Date Folder**: OFF / ON Set the creation of date file folders.
 - Auto Naming**: Numbering / Date Set the auto file naming method (Date, Numbering).
 - File Name**: Set the waveform parameter file name.
- Beep** (checked): Set the beep sound.
- Send Mail** (checked): Mail Count: 100 Set mail transmission and the number of mail transmissions.

14.2 Performing GO/NO-GO Determination with Waveform Parameters

This section explains the following settings for performing GO/NO-GO determination with waveform parameters:

Applicable in Scope Mode

- Selecting the mode
- Judgment conditions

► [“Waveform Parameter \(Parameter\)”](#) and [“Automated Measurement of Waveform Parameters”](#) in the Features Guide

GO/NO-GO Menu

1. On the waveform screen’s MENU, tap **ANALYSIS > GO/NOGO**, or press **SHIFT+MEASURE (GO/NO-GO)**. The following screen appears.

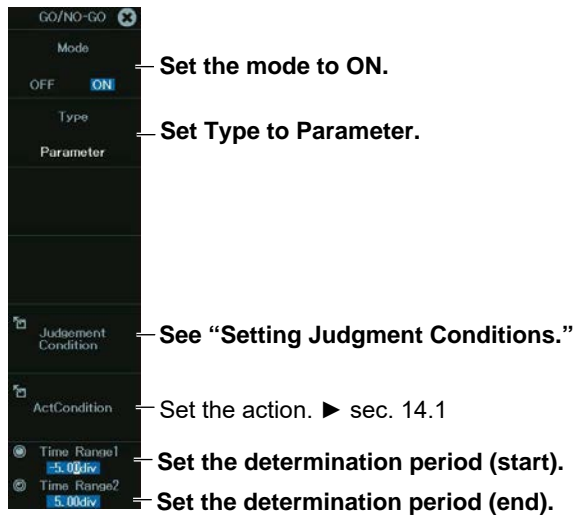

Setting the Judgment Conditions (Judgement Setup)

2. Tap **Judgement Setup**, or press the soft key. The following screen appears.

Set the judgment criterion (X, IN, OUT).
 Select the source waveform (CH1 to CH16, Math1 to Math8, FFT1 to FFT8).
 Select the source parameter.
 Set the upper parameter limit.
 Set the lower parameter limit.

#	Mode	Trace	Item	Upper	Lower
1	OUT	CH1	Peak to Peak	0.0000	0.0000
2	IN	CH1	Peak to Peak	0.0000	0.0000
3	X	CH1	Peak to Peak	0.0000	0.0000
4	X	CH1	Peak to Peak	0.0000	0.0000
5	X	CH1	Peak to Peak	0.0000	0.0000
6	X	CH1	Peak to Peak	0.0000	0.0000
7	X	CH1	Peak to Peak	0.0000	0.0000
8	X	CH1	Peak to Peak	0.0000	0.0000

Logic: AND OR
 ActCondition: Always Fail Success
 Sequence: Single Continue
 Acquisition Count: Infinite
 Remote: OFF ON

Scroll bar
 Scroll to display reference conditions that do not fit in the screen.

Set the determination logic (AND, OR).
 Set the action condition (Always, Fail, Success).
 Set the sequence (Single, Continue).
 Set the number of waveforms to acquire.
 Turns external start on or off

Setting Waveform Parameters (Item)

You can use all 27 automatically measured waveform parameters as reference conditions. You can perform GO/NO-GO determination on up to 16 parameters at the same time. ▶ sec. 11.1

Chapter 15

Actions

Main Control Areas Used in This Chapter

You can also use the touch panel.

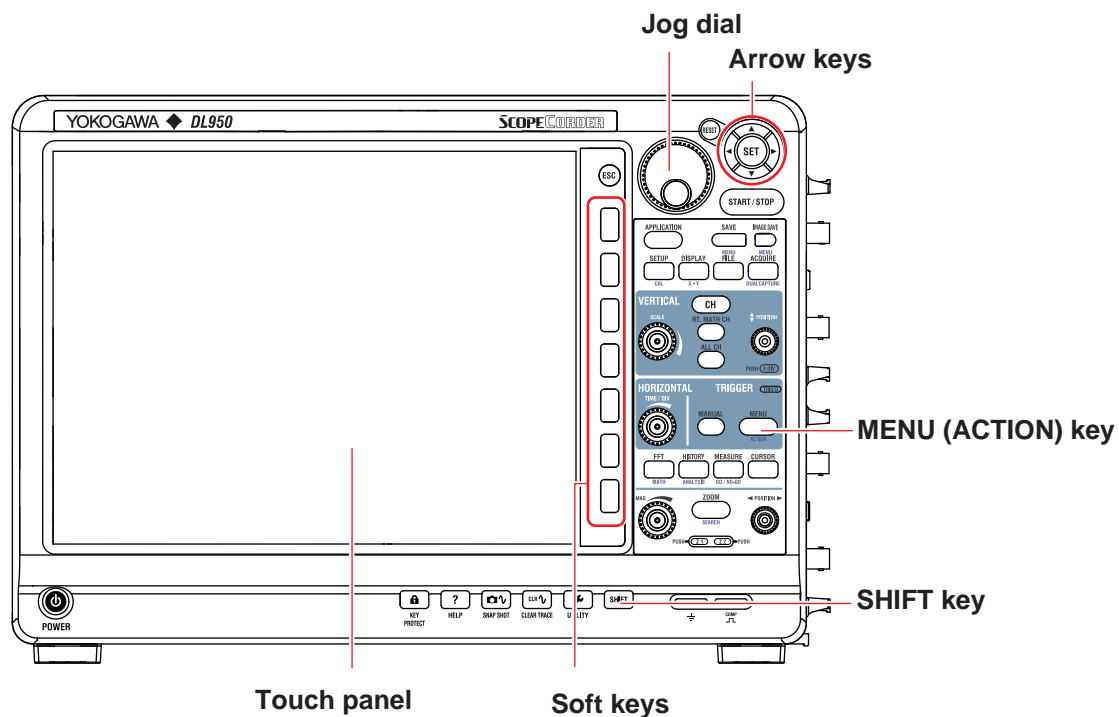

Operation Modes Applicable to the Sections in This Chapter

✓: Applicable, -: Not applicable

Section	Scope Mode	Recorder Mode
15.1 Setting Actions	✓	✓

* The settings may vary depending on the operation mode.

15.1 Setting Actions

This section explains the following settings for executing the action function:

Items Common to Scope Mode and Recorder Mode

- Action mode
- Action to execute

► [“Action” in the Features Guide](#)

ACTION menu

1. On the waveform screen's MENU, tap **TRIGGER > ACTION**, or press **SHIFT+MENU (ACTION)**. The following screen appears.

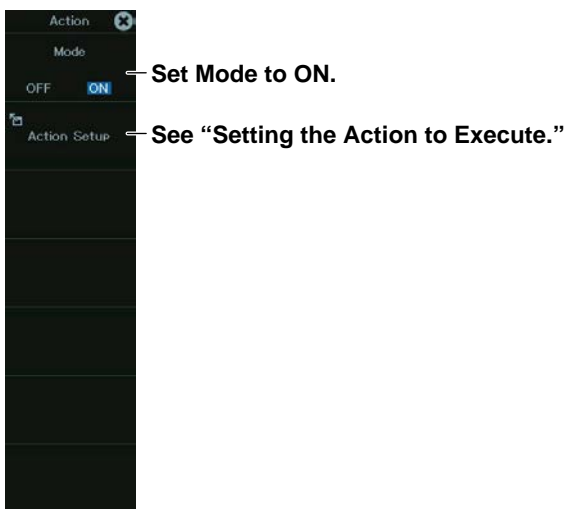

Setting the Action to Execute (Action Setup)

2. Tap **Action Setup**, or press the soft key. The following screen appears.

When Dual Capture Mode Is Off

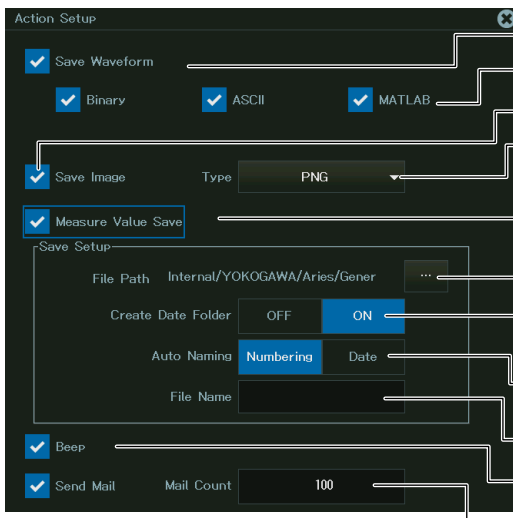

Saves the waveform data

Waveform data format

Saves a screen capture

Screen capture data format (PNG, BMP, JPEG)

Saves waveform parameters measured automatically

Set the waveform parameter save destination.

Set the creation of date file folders.

Set the auto file naming method (Date, Numbering).

Set the waveform parameter file name.

Set the beep sound.

Set mail transmission and the number of mail transmissions.

When Dual Capture Mode Is On

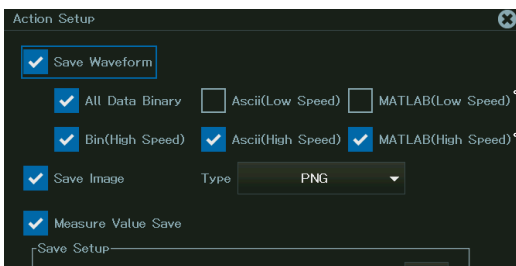

Low-speed sampling waveform data format

High-speed sampling waveform data format

Note

When SSD recording is enabled, you cannot set actions.

Executing Actions

After you set the action mode, the actions to execute, and the number of times to execute the actions, press **START/STOP**. The actions will be executed each time that the Instrument triggers. "ACTION" appears at the top center of the screen when an action is being executed. To stop, press **START/STOP**.

Note

- If the action to execute is mail transmission and the specified number of mail transmissions is less than the number of specified actions, mail transmission will stop after the specified number of transmissions. If the specified number of mail transmissions is greater than the number of specified actions, mail transmission will stop after the specified number of actions.
- The action settings are shared with the action settings of GO/NO-GO.

Chapter 16

Real Time Math (/G03, /G05 option)

Main Control Areas Used in This Chapter

You can also use the touch panel.

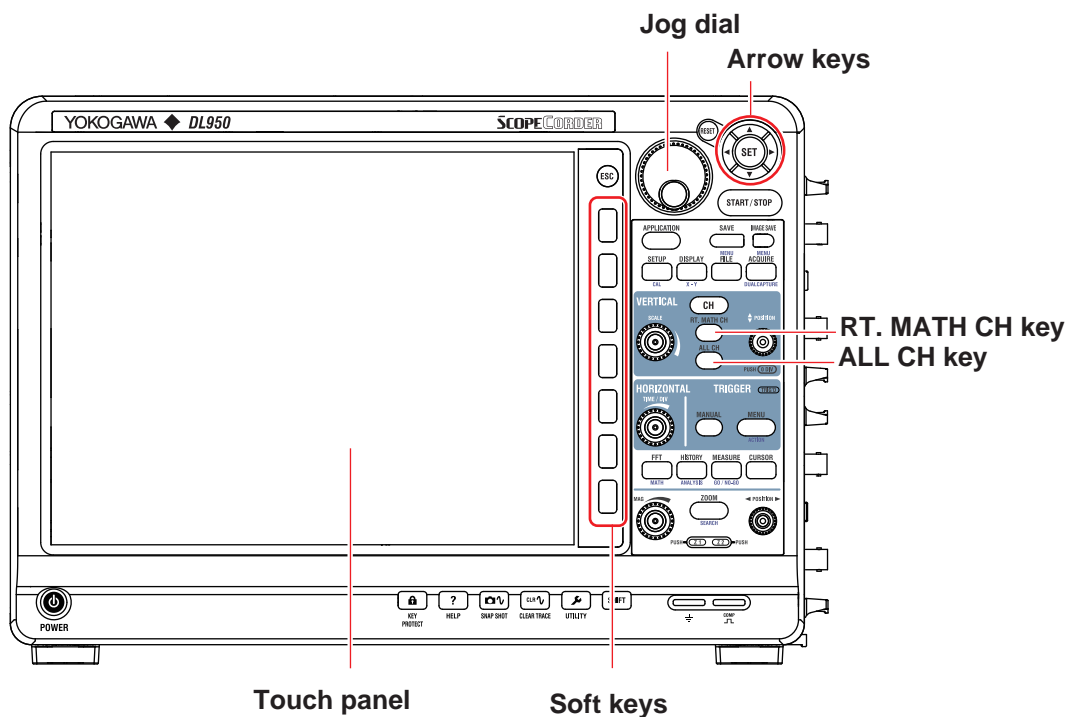

Operation Modes Applicable to the Sections in This Chapter

✓: Applicable, -: Not applicable

Section	Scope Mode	Recorder Mode
16.1 Configuring Real Time Math	✓	✓
16.2 Configuring with the All Channel Setup Menu	✓	✓

* The settings may vary depending on the operation mode.

16.1 Configuring Real Time Math

This section explains the following real time math settings.

Items Common to Scope Mode and Recorder Mode

- Turning real time math on and off
- Setting labels
- Setting real time math expressions
- Setting the scaling
- Setting the unit
- Setting display groups

► [“Real Time Math \(/G03, /G05 option\)” in the Features Guide](#)

RealTime Math Menu

1. On the waveform screen’s MENU, tap **CH > RT.MATH CH**, or press **RT. MATH CH**. A real time math setup menu appears.
2. Tap a real time math channel you want to configure, or select the channel using the jog dial or up and down arrow keys.

RealTime Math menu (1/2)

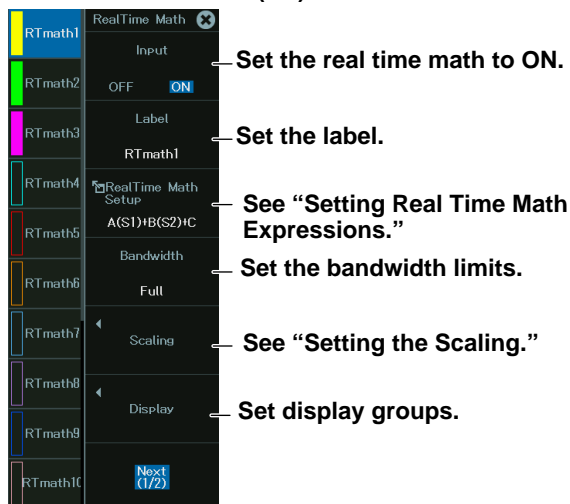

RealTime Math menu (2/2)

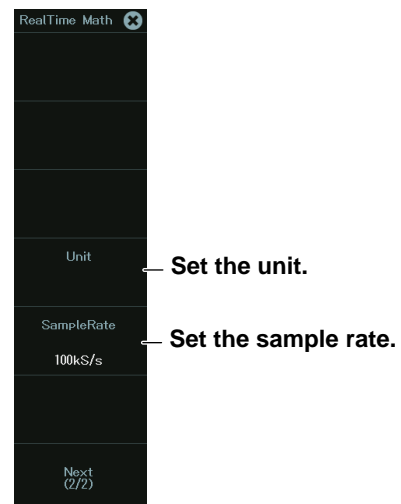

Setting Real Time Math Expressions

3. Tap **RealTime Math Setup**, or press the soft key. The following screen appears.

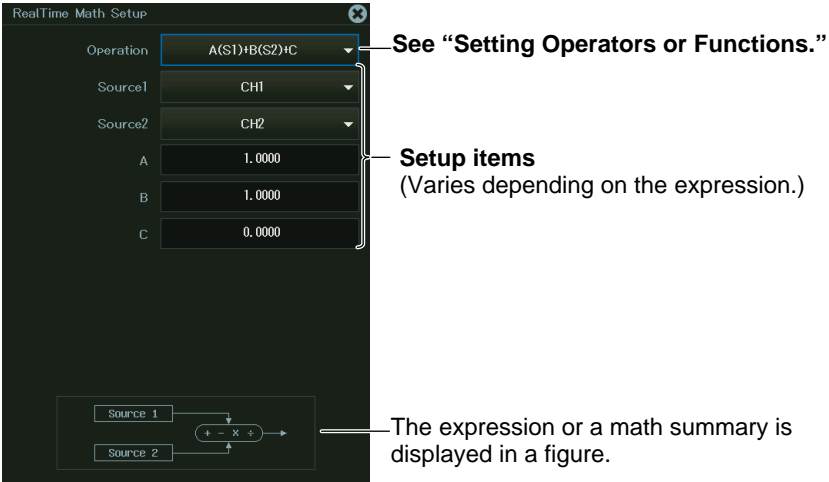

Setting Operators or Functions

4. Tap the **Operation** box, or select the Operation box using the jog dial or arrow keys, and press **SET**. The following screen appears.

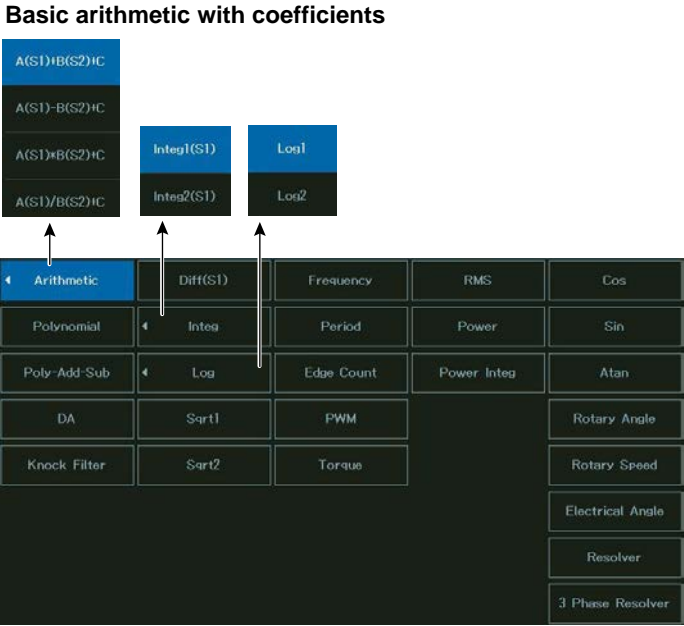

Basic Arithmetic with Coefficients ($A(S1)+B(S2)+C$, $A(S1)-B(S2)+C$, $A(S1)*B(S2)+C$, and $A(S1)/B(S2)+C$)

The following screen appears when you select a basic arithmetic operation with coefficients.

Operation $A(S1)+B(S2)+C$ → **Select $A(S1)+B(S2)+C$, $A(S1)-B(S2)+C$, $A(S1)*B(S2)+C$, or $A(S1)/B(S2)+C$.**

Source1 CH1 → **Select the math source waveform (channel whose acquisition is set to ON).**

Source2 CH2 → **Select the math source waveform (channel whose acquisition is set to ON).**

A 1.0000 → **Scale value**

B 1.0000 → **Scale value**

C 0.0000 → **Scale value**
(Basic arithmetic without coefficients is selected when you set scale value A and B to 1 and offset value C to 0.)

Quartic Polynomial (Polynomial)

The following screen appears when you select the quartic polynomial function.

Operation Polynomial → **Select Polynomial.**

Source CH1 → **Select the math source waveform.**

A 1.0000 → **Set coefficients.**

B 1.0000 → **Set coefficients.**

C 0.0000 → **Set coefficients.**

D 0.0000 → **Set coefficients.**

E 0.0000 → **Set coefficients.**

Polynomial (Poly-Add-Sub)

The following screen appears when you select the polynomial function.

Operation Poly-Add-Sub → **Select Poly-Add-Sub.**

Source1 CH1 → **Select the math source waveform.**

Source2 CH2 → **Select the math source waveform.**

Source3 CH3_1 → **Select the math source waveform.**

Source4 CH8 → **Select the math source waveform.**

K 1.0000 → **Set coefficients.**

Signs (+, -) → **Select the sign (+, -).**
Tap the polarity you want to select, or select the polarity with the jog dial, and press SET.

Logic Signal and Analog Waveform Conversion (DA)

The following screen appears when you select the logic signal and analog waveform conversion function.

Operation DA → **Select DA.**

Source1 CH5 → **Select the math source logic signal (least significant 8 bits).**
The channels of installed logic modules are displayed.

Source2 CH6 → **Select the math source logic signal (most significant 8 bits).**
The channels of installed logic modules are displayed.

Type Signed → **Select the conversion method (Unsigned, Signed, Offset Binary).**

Bit Length 16 → **Set the bit length.**

K 1.0000 → **Set coefficients.**

Knocking Filter (Knock Filter) (/VCE option)

The following screen appears when you select the knocking filter function.

The screenshot shows the 'RealTime Math Setup' window with the following settings: Operation: Knock Filter, Source: CH1, Elimination Level: 0.0V, and Differential: ON. Arrows point from text labels to these settings.

- Select Knock Filter.
- Select the math source waveform.
- Set the elimination level.
- Turns differentiation on or off

Differentiation (Diff(S1))

The following screen appears when you select the differentiation function.

The screenshot shows the 'RealTime Math Setup' window with the following settings: Operation: Diff(S1), Source: CH1, and Calc Period: 10MHz. Arrows point from text labels to these settings.

- Select RMS(S1).
- Select the math source waveform.
- calculation period

Integration (Integ1(S1) and Integ2(S1))

The following screen appears when you select the integration function.

The screenshot shows the 'RealTime Math Setup' window for Integ1(S1) with various settings. Arrows point from text labels to these settings.

- Select Integ1(S1) or Integ2(S1).
- Select the math source waveform.
- Resets the integration result when waveform acquisition starts
- Resets the integration result when the math source waveform exceeds the specified threshold
- Set the threshold.
- Resets the integration result when the math source waveform crosses zero and an edge is generated
- Set the zero-crossing edge (f, r).
- Set the zero-crossing hysteresis (A, A, A).
- Resets the integration result manually

Common Logarithm (Log1 and Log2)

Log1

The following screen appears when you select the common logarithm function (Log1).

The screenshot shows the 'RealTime Math Setup' window for Log1 with the following settings: Operation: Log1, Source1: CH1, Source2: CH2, and K: 1.0000. Arrows point from text labels to these settings.

- Select Log1.
- Select the math source waveform.
- Set coefficients.

Log2

The following screen appears when you select the common logarithm function (Log2).

The screenshot shows the 'RealTime Math Setup' window for Log2 with the following settings: Operation: Log2, Source: CH1, and K: 1.0000. Arrows point from text labels to these settings.

- Select Log2.
- Select the math source waveform.
- Set coefficients.

Square Root (Sqrt1 and Sqrt2)

Sqrt1

The following screen appears when you select the square root function (Sqrt1).

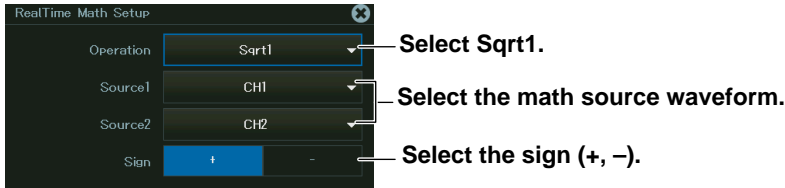

Note

When you set Sign to +, the square root of "S1*S1 + S2*S2" is calculated.
 When you set Sign to -, the square root of "S1*S1 - S2*S2" is calculated.

Sqrt2

The following screen appears when you select the square root function (Sqrt2).



Frequency (Frequency)

The following screen appears when you select the frequency function.

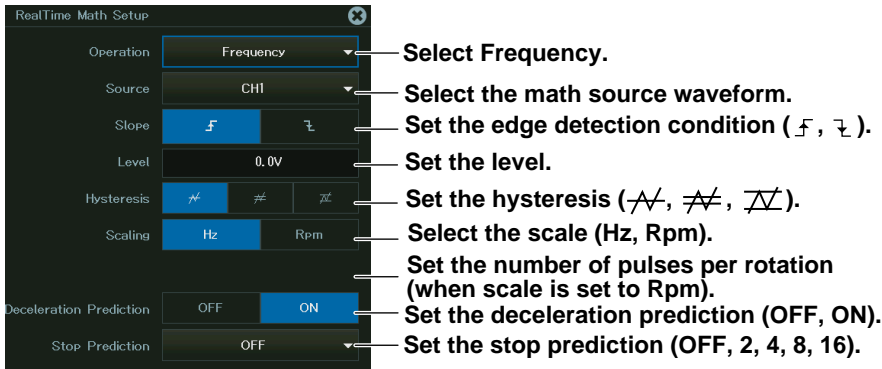

Period (Period)

The following screen appears when you select the period function.

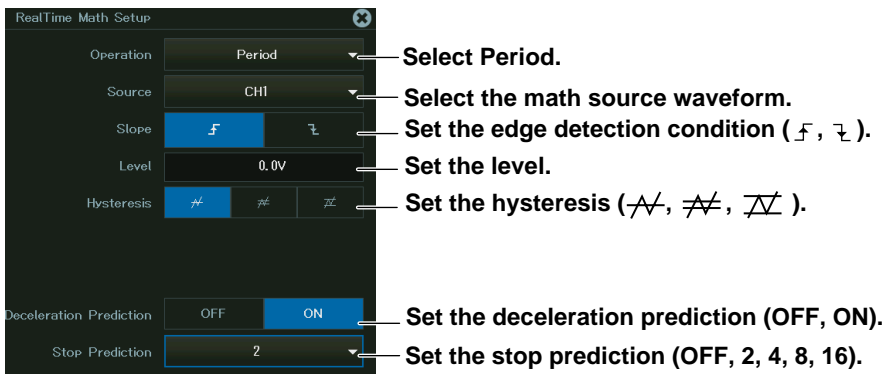

Edge Count (Edge Count)

The following screen appears when you select the edge count function.



Annotations for Edge Count function:

- Operation: Edge Count (Select Edge Count.)
- Source: CHI (Select the math source waveform.)
- Slope: f, r (Set the edge detection condition (f, r).)
- Level: 0.0V (Set the level used to detect edges.)
- Hysteresis: ~~AV~~, ~~AV~~, ~~AV~~ (Set the hysteresis (~~AV~~, ~~AV~~, ~~AV~~)).
- Reset Condition: Start (Resets the counter when waveform acquisition starts)
- Reset Condition: Overlimit (Resets the counter when the specified limit value is exceeded)
- OverlimitValue: 0.0000 (Resets the limit value that resets the counter)
- Manual Reset: Execute (Manually resets the counter)

Demodulation of the Pulse Width Modulated Signal (PWM)

When you select the function that is used to demodulate pulse width modulated signals, the following screen appears.



Annotations for PWM function:

- Operation: PWM (Select PWM.)
- Source: CHI (Select the math source waveform.)
- Period: 0.1us (Set the period.)

Torque (Torque)

The following screen appears when you select the torque function.

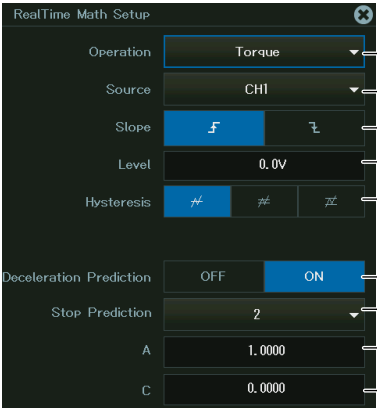

Annotations for Torque function:

- Operation: Torque (Select Torque.)
- Source: CHI (Select the math source waveform.)
- Slope: f, r (Set the edge detection condition (f, r).)
- Level: 0.0V (Set the level.)
- Hysteresis: ~~AV~~, ~~AV~~, ~~AV~~ (Set the hysteresis (~~AV~~, ~~AV~~, ~~AV~~)).
- Deceleration Prediction: OFF, ON (Set the deceleration prediction (OFF, ON).)
- Stop Prediction: 2 (Set the stop prediction (OFF, 2, 4, 8, 16).)
- A: 1.0000 (Set coefficients.)
- C: 0.0000 (Set coefficients.)

RMS Value (RMS)

The following screen appears when you select the rms function.

If the Calculation Period Is Edge

RealTime Math Setup

- Operation: RMS → Select RMS.
- Source: CH1 → Select the math source waveform.
- Calc Period: Edge | Time → Set the calculation period to Edge.
- Calc Period:
 - Edge Source: Own → Set the source waveform used to detect edges (Own, CH1 to CH16,¹ RTmath1 to RTmath15²).
 - Level: 0.0V → Set the level.
 - Slope: f | r | fr → Set the edge detection condition (f, r, fr).
 - Hysteresis: / | ≠ | // → Set the hysteresis (/, ≠, //).

- 1 You can select channels in which input modules that support basic arithmetic are installed.
- 2 You can select channels whose numbers are smaller than the channel you are editing.

If the Calculation Period Is Time

RealTime Math Setup

- Operation: RMS → Select RMS.
- Source: CH1 → Select the math source waveform.
- Calc Period: Edge | Time → Set the calculation period to Time.
- Time: 1ms → Set the hours.

Effective Power (Power)

The following screen appears when you select the effective power function.

RealTime Math Setup

- Operation: Power → Select Power.
- Source1: CH1 → Select the math source waveform.
- Source2: CH2 → Set the math range.
- Calc Period:
 - Edge Source: Source1 → Set the source waveform used to detect edges (Own, CH1 to CH16,¹ RTmath1 to RTmath15²).
 - Level: 0.0V → Set the level.
 - Slope: f | r | fr → Set the edge detection condition (f, r, fr).
 - Hysteresis: / | ≠ | // → Set the hysteresis (/, ≠, //).

- 1 You can select channels in which input modules that support basic arithmetic are installed.
- 2 You can select channels whose numbers are smaller than the channel you are editing.

Effective Power Integration (Power Integ)

The following screen appears when you select the effective power integration function.

RealTime Math Setup

- Operation: Power Integ → Select Power Integ.
- Source1: CH1 → Select the math source waveform.
- Source2: CH2 → Resets the integration result when waveform acquisition starts
- Reset Condition:
 - Start → Resets the integration result when the specified limit value is exceeded
 - Overlimit → Limit value used to reset the integration result
- OverlimitValue: 0.0000
- Manual Reset: Execute → Resets the integration result manually
- Scaling: Second | Hour → Select the scale (Second, Hour).

Cosine (Cos) and Sine (Sin)

The following screen appears when you select the cosine or sine function.

When the Encode Type Is Set to Incremental ABZ, Incremental AZ, Incremental AB, or Incremental A

RealTime Math Setup

- Operation: Cos
- Type: Incremental ABZ
- Source Condition: Setup
- Pulse/Rotate: 180
- Encode Condition: Setup
- Manual Reset
- Execute

Annotations:

- Select Cos or Sin.
- Set the encode type to Incremental ABZ, Incremental AZ, Incremental AB, or Incremental A.
- See "Setting the Source Conditions."
- Set the number of pulses per rotation.
- See "Setting the Encoding Conditions."
- Resets the math result manually

Setting the Source Conditions

When the logic source is ON

Source Condition

- Logic Source: ON
- Source: CH5
- Phase A: Bit1
- Phase B: Bit2
- Phase Z: Bit3
- Phase Z Invert:

Annotations:

- Set the logic source to ON.
- Set the source channel (input channel of a logic module). (Only the channels with logic modules installed are displayed.)
- Select the bits of logic signals of phases A, B, and Z (Bit1 to Bit8).
- Select the check box when the Z-phase input is inverted.

When the logic source is OFF

Source Condition

- Logic Source: OFF
- Phase A: CH1, Level: 0.0V, Hysteresis:
- Phase B: CH2, Level: 0.0V, Hysteresis:
- Phase Z: CH3_1, Level: 0V, Hysteresis: Phase Z Invert

Annotations:

- Set the logic source to OFF.
- Set the phase A signal channel.
- Set the signal level to count.
- Set the hysteresis (, ,).
- Set phase B.*
- Set phase Z.*
- Select the check box when the Z-phase input is inverted.

* Phase B and phase Z settings are not displayed depending on the encode type.

Setting the Encoding Conditions

When the count condition is x1



- Set the count condition to x1.
- Set the number of count per rotation.
- Select the edge to count pulses on¹ (A^F, A^L, B^F, B^L)
- Select the edge to reset the value on¹ (A^F, A^L, B^F, B^L, Z Level²)
- Turns rotation direction inversion on or off

When the encoding type is Incremental ABZ or Incremental AB and the count condition is x2

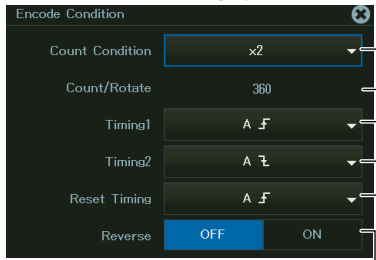

- Set the count condition to x2.
- Set the number of count per rotation.
- Select the edge to count pulses on (A^F, A^L, B^F, B^L)
- Select the edge to count pulses on (A^F, A^L, B^F, B^L)
- Select the edge to reset the value on (A^F, A^L, B^F, B^L, Z Level²)
- Turns rotation direction inversion on or off

When the encoding type is Incremental ABZ or Incremental AB and the count condition is x4 When the encoding type is Incremental AZ or Incremental A and the count condition is x2

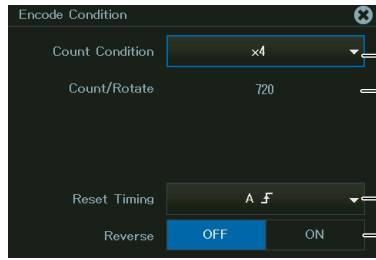

- Set the count condition to x2 or x4.
- Set the number of count per rotation.
- Select the edge to reset the value on¹ (A^F, A^L, B^F,¹ B^L,¹ Z Level²)
- Turns rotation direction inversion on or off

- 1 Can be set when the Encoding Type is Incremental ABZ or Incremental AB
- 2 Can be set when the Encoding Type is Incremental ABZ or Incremental AZ

When the Encode Type Is Set to Absolute 8bit, Absolute 16bit, or Gray Code

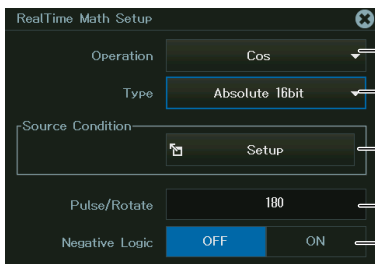

- Select Cos or Sin.
- Set the encode type to Absolute 8bit, Absolute 16bit, or Gray Code.
- See "Setting the Source Conditions."
- Set the number of pulses per rotation.
- Turns negative logic on or off

Setting the Source Conditions

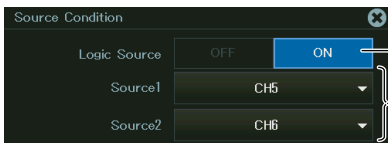

- Set the logic source to ON.
- Set the source channel* (input channel of a logic module). (Only the channels with logic modules installed are displayed.)

* Source2 can be set when the encode type is set to Absolute 16bit or Gray Code. Set the logic channel for the least significant digits to Source1 and the logic channel for the most significant digits to Source2.

When the Encode Type Is Set to Resolver Ch (available when a channel with a number smaller than the channel you are editing is set to Resolver or 3Phase Resolver)

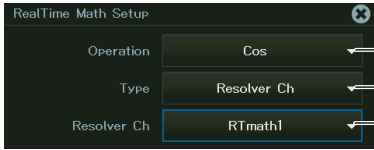

- Select Cos or Sin.
- Set the encode type to Resolver Ch.
- Set the source channel.*

* Select a channel in which the operator is set to Resolver or 3 Phase Resolver in a real time math function with a number smaller than the number of the channel you are editing.

Arc Tangent (Atan)

The following screen appears when you select the arc tangent function.

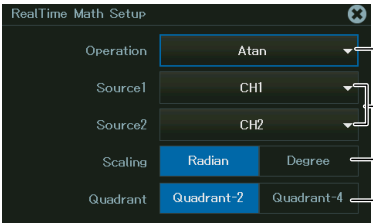

- Select Atan.
- Set the math source waveform.
- Set the scale (Radian, Degree).
- Set the quadrant range (Quadrant-2, Quadrant-4).

Rotation Angle (Rotary Angle)

The following screen appears when you select the rotary angle function.

When the Encode Type Is Set to Incremental ABZ, Incremental AZ, Incremental AB, or Incremental A

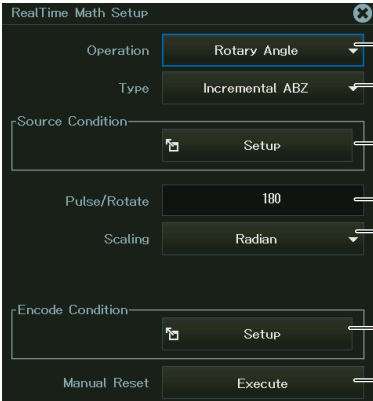

- Select Rotary Angle.
- Set the encode type II Incremental ABZ, Incremental AZ, Incremental AB, or Incremental A.
- See "Setting the Source Conditions."
- Set the number of pulses per rotation.
- Set the scaling. (Radian, Degree, User Define)
- See "Setting the Encoding Conditions."
- Resets the math result manually

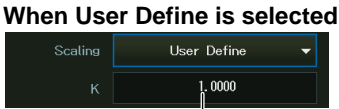

Set the scaling factor.

Setting the Source Conditions

When the logic source is ON

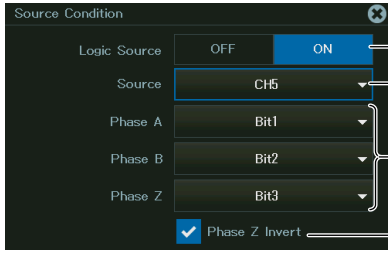

- Set the logic source to ON.
- Set the source channel (input channel of a logic module). (Only the channels with logic modules installed are displayed.)
- Select the bits of logic signals of phases A, B, and Z (Bit1 to Bit8).
- Select the check box when the Z-phase input is inverted.

When the logic source is OFF



- Set the logic source to OFF.
- Set the phase A signal channel.
- Set the signal level to count.
- Set the hysteresis (~~AV~~, ~~AV~~, ~~AV~~).
- Set phase B.*
- Select the check box when the Z-phase input is inverted.
- Set phase Z.*

* Phase B and phase Z settings are not displayed depending on the encode type.

Setting the Encoding Conditions

When the count condition is x1

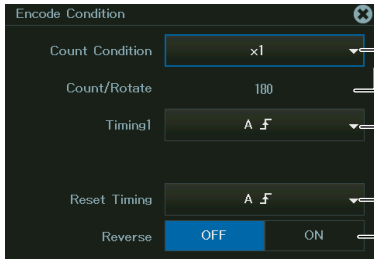

- Set the count condition to x1.
- Number of counts per rotation
- Select the edge to count pulses on¹
(A falling, A rising, B falling, B rising)
- Select the edge to reset the value on¹
(A falling, A rising, B falling, B rising, Z Level²)
- Turns rotation direction inversion on or off

When the encoding type is Incremental ABZ or Incremental AB and the count condition is x2

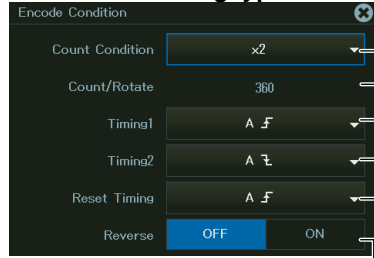

- Set the count condition to x2.
- Number of counts per rotation
- Select the edge to count pulses on
(A falling, A rising, B falling, B rising)
- Select the edge to count pulses on
(A falling, A rising, B falling, B rising)
- Select the edge to reset the value on
(A falling, A rising, B falling, B rising, Z Level²)
- Turns rotation direction inversion on or off

When the encoding type is Incremental ABZ or Incremental AB and the count condition is x4
When the encoding type is Incremental AZ or Incremental A and the count condition is x2

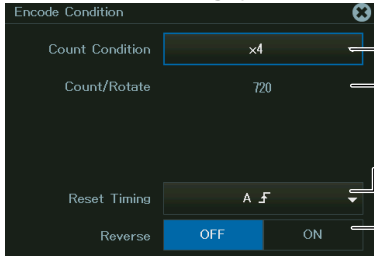

- Set the count condition to x2 or x4.
- Number of counts per rotation
- Select the edge to reset the value on
(A falling, A rising, B falling, B rising, Z Level²)
- Turns rotation direction inversion on or off

- 1 Can be set when the Encoding Type is Incremental ABZ or Incremental AB
- 2 Can be set when the Encoding Type is Incremental ABZ or Incremental AZ

When the Encode Type Is Set to Absolute 8bit, Absolute 16bit, or Gray Code

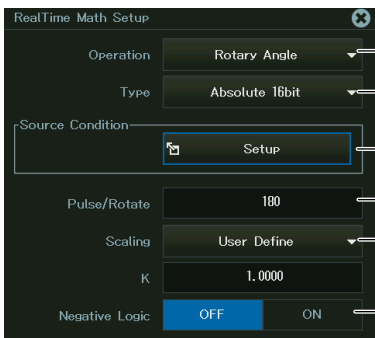

- Select Rotary Angle.
- Set the encode type to Absolute 8bit, Absolute 16bit, or Gray Code.
- See "Setting the Source Conditions."
- Set the number of pulses per rotation.
- Set the scaling.
(Radian, Degree, User Define)
- Turns negative logic on or off

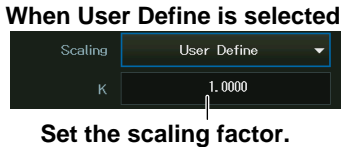

Set the scaling factor.

Setting the Source Conditions

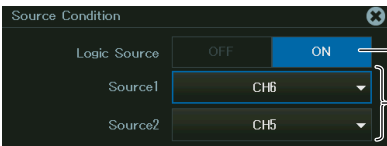

- Set the logic source to ON.
- Set the source channel* (input channel of a logic module).
(Only the channels with logic modules installed are displayed.)

* Source2 can be set when the encode type is set to Absolute 16bit or Gray Code.

Rotary Speed (Rotary Speed)

The following screen appears when you select the rotary speed function.

RealTime Math Setup

- Operation: Rotary Speed — Select Rotary Speed.
- Type: Incremental AB — The encoding type is fixed to Incremental AB.
- Source Condition: Setup — See “Setting the Source Conditions.”
- Pulse/Rotate: 1 — Set the number of pulses per rotation.
- Scaling: Hz — Set the scaling. (Hz, Rpm, User Define) — When User Define is selected, Set the scaling factor.
- Encode Condition: Setup — See “Setting the Encoding Conditions.”
- Deceleration Prediction: ON — Turns decelerating prediction on or off
- Stop Prediction: 4 — Set the stop prediction (OFF, 2, 4, 8, 16).

Setting the Source Conditions

When the logic source is ON

Source Condition

- Logic Source: ON — Set the logic source to ON.
- Source: CH7 — Set the source channel (input channel of a logic module). (Only the channels with logic modules installed are displayed.)
- Phase A: Bit1 — Select the bits of logic signals of phases A and B (Bit1 to Bit8).
- Phase B: Bit2

When the logic source is OFF

Source Condition

- Logic Source: OFF — Set the logic source to OFF.
- Phase A: CH3 — Set the phase A signal channel.
- Level: 0.0V — Set the signal level to count.
- Hysteresis: \neq — Set the hysteresis (\neq , \neq , \neq).
- Phase B: CH3 — Set phase B.
- Level: 0.0V
- Hysteresis: \neq

Setting the Encoding Conditions

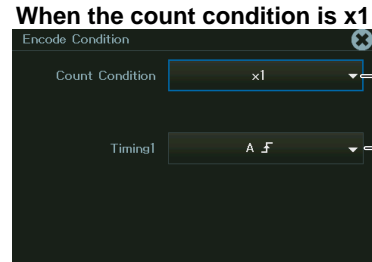

Set the count condition to x1.

Select the edge to count pulses on!
(A f , A f̄ , B f , B f̄)

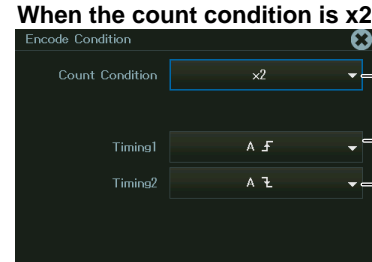

Set the count condition to x2.

Select the edge to count pulses on
(A f , A f̄ , B f , B f̄)

Select the edge to count pulses on
(A f , A f̄ , B f , B f̄)

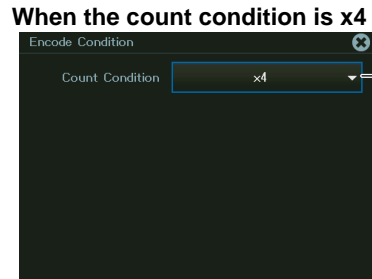

Set the count condition to x4.

Electrical Angle (Electrical Angle)

The following screen appears when you select the electrical angle function.

When the Encode Type Is Set to Incremental ABZ, Incremental AZ, Incremental AB, or Incremental A

The screenshot shows the 'RealTime Math Setup' dialog box with the following settings and annotations:

- Operation:** Electrical Angle (Annotation: Select Electrical Angle.)
- Type:** Incremental ABZ (Annotation: Set the encode type to Incremental ABZ, Incremental AZ, Incremental AB, or Incremental A.)
- Source Condition:** Setup (Annotation: See "Setting the Source Conditions.")
- Pulse/Rotate:** 180 (Annotation: Set the number of pulses per rotation.)
- Scaling:** Radian (Annotation: Select the scaling (Radian, Degree).)
- Encode Condition:** Setup (Annotation: See "Setting the Encoding Conditions.")
- Target:** CH3_1 (Annotation: Select the target (CH1 to CH16, 1 RTmath1 to RTmath15²).

- 1: You can select channels in which input modules that support basic arithmetic are installed.
- 2: You can select channels whose numbers are smaller than the channel you are editing.

Setting the Source Conditions

The screenshot shows the 'Source Condition' dialog box with the following settings and annotations:

- Logic Source:** ON (Annotation: The logic source is fixed to ON.)
- Source:** CH5 (Annotation: Set the source channel (input channel of a logic module). (Only the channels with logic modules installed are displayed.)
- Phase A:** Bit1 (Annotation: Select the bits of logic signals of phases A, B, and Z (Bit1 to Bit8).)
- Phase B:** Bit2 (Annotation: Select the bits of logic signals of phases A, B, and Z (Bit1 to Bit8).)
- Phase Z:** Bit3 (Annotation: Select the bits of logic signals of phases A, B, and Z (Bit1 to Bit8).)
- Phase Z Invert:** (Annotation: Select the check box when the Z-phase input is inverted.)

Setting the Encoding Conditions

When the count condition is x1

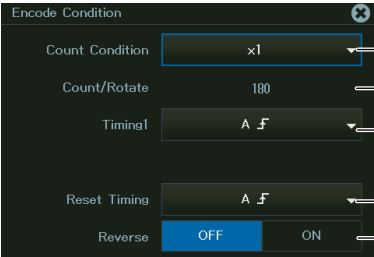

- Set the count condition to x1.
- Number of counts per rotation
- Select the edge to count pulses on¹ (A falling, A rising, B falling, B rising)
- Select the edge to reset the value on¹ (A falling, A rising, B falling, B rising, Z Level²)
- Turns rotation direction inversion on or off

When the encoding type is Incremental ABZ or Incremental AB and the count condition is x2



- Set the count condition to x2.
- Number of counts per rotation
- Select the edge to count pulses on (A falling, A rising, B falling, B rising)
- Select the edge to count pulses on (A falling, A rising, B falling, B rising)
- Select the edge to reset the value on (A falling, A rising, B falling, B rising, Z Level²)
- Turns rotation direction inversion on or off

When the encoding type is Incremental ABZ or Incremental AB and the count condition is x4
When the encoding type is Incremental AZ or Incremental A and the count condition is x2

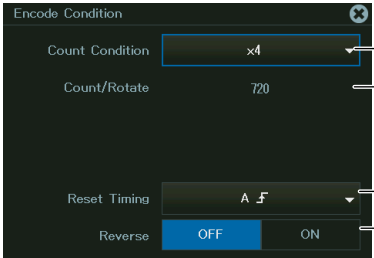

- Set the count condition to x2 or x4.
- Number of counts per rotation
- Select the edge to reset the value on¹ (A falling, A rising, B falling, B rising, Z Level²)
- Turns rotation direction inversion on or off

- 1 Can be set when the Encoding Type is Incremental ABZ or Incremental AB
- 2 Can be set when the Encoding Type is Incremental ABZ or Incremental AZ

When the Encode Type Is Set to Absolute 8bit, Absolute 16bit, or Gray Code

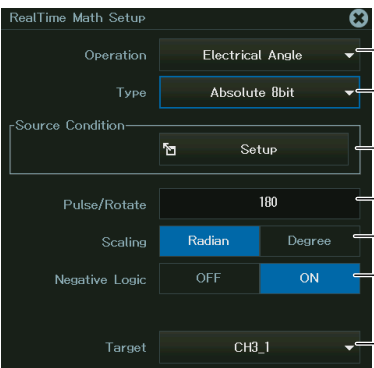

- Select Electrical Angle.
- Set the encode type to Absolute 8bit, Absolute 16bit, or Gray Code.
- See "Setting the Source Conditions."
- Set the number of pulses per rotation.
- Set the vertical scale unit (Radian, Degree).*
- Turns negative logic on or off
- Set the target.

* This setting is shared with the Rotary Angle setting.

Setting the Source Conditions

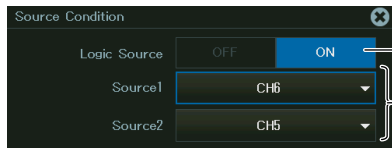

- Set the logic source to ON.
- Set the source channel* (input channel of a logic module). (Only the channels with logic modules installed are displayed.)

* Source2 can be set when the encode type is set to Absolute 16bit or Gray Code. Set the logic channel for the least significant digits to Source1 and the logic channel for the most significant digits to Source2.

Resolver (Resolver)

The following screen appears when you select the resolver function.

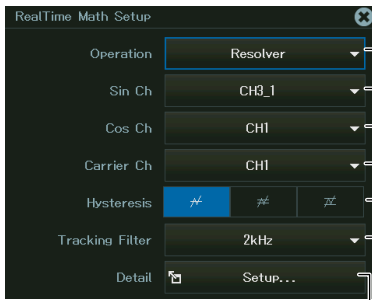

- Select Resolver.
- Select the Sin phase signal (CH1 to CH16,¹ RTmath1 to RTmath15²).
- Select the Cos phase signal (CH1 to CH16,¹ RTmath1 to RTmath15²).
- Select the excitation signal (CH1 to CH16,¹ RTmath1 to RTmath15²).
- Select the hysteresis (\neq , \neq , \neq).
- Select the tracking filter. (OFF, 2kHz, 1kHz, 250Hz, 100Hz) See "Detail Setup."

- 1: You can select channels in which input modules that support basic arithmetic are installed.
- 2: You can select channels whose numbers are smaller than the channel you are editing.

Detail Setup



- Select the sample point mode (Auto, Manual).
- Set the move time of the sample point. (Only when Mode is set to Manual)
- Select the scale (-180° to +180°, 0° to 360°, $-\pi$ to $+\pi$, 0 to 2π).
- Set the offset.

3 Phase Resolver(3 Phase Resolver)

The following screen appears when you select the 3 phase resolver function.

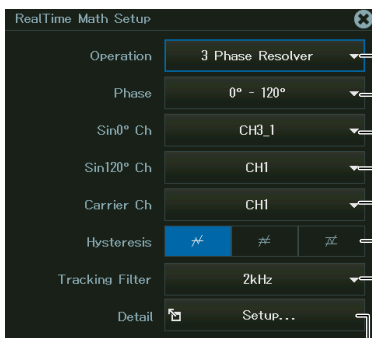

- Select 3 Phase Resolver.
- Set the phase of the sine signal (0° to 120°, 0° to 240°, 120° to 240°).
- Set the Sin signal (CH1 to CH16,¹ RTmath1 to RTmath15²).
- Set the excitation signal (CH1 to CH16,¹ RTmath1 to RTmath15²).
- Set the hysteresis (\neq , \neq , \neq).
- Set the tracking filter (OFF, 2kHz, 1kHz, 250Hz, 100Hz). See "Detail Setup."

- 1: You can select channels in which input modules that support basic arithmetic are installed.
- 2: You can select channels whose numbers are smaller than the channel you are editing.

Detail Setup

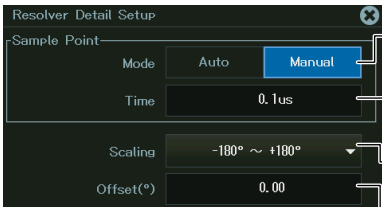

Resolver Detail Setup

Sample Point

Mode: Auto **Manual**

Time: 0.1us

Scaling: -180° ~ +180°

Offset(°): 0.00

- Select the sample point mode (Auto, Manual).
- Set the move time of the sample point. (Only when Mode is set to Manual)
- Select the scale (-180° to +180°, 0° to 360°, - π to + π , 0 to 2π).
- Set the offset.

Setting the Scaling

3. Tap Scaling, or press the soft key. The following screen appears.

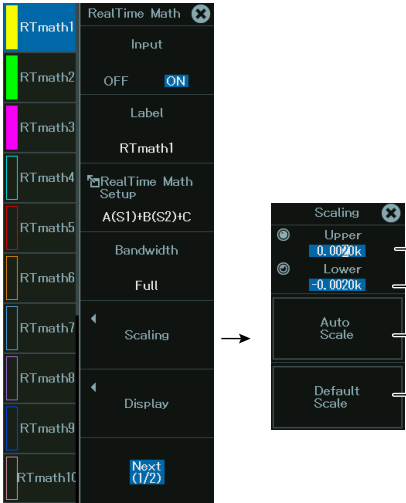

Real Time Math

- RTmath1
- RTmath2 OFF **ON**
- RTmath3 Label RTmath1
- RTmath4 Real Time Math Setup $A(S1)+B(S2)+C$
- RTmath5 Bandwidth
- RTmath6 Full
- RTmath7 **Scaling**
- RTmath8 Display
- RTmath9
- RTmath10 **Next (1/2)**

Scaling

Upper: 0.0020k

Lower: -0.0020k

Auto Scale

Default Scale

- Set the upper display range limit.
- Set the lower display range limit.
- Executes auto scaling
- Resets the scale to its default

Auto Scale: The scale is set automatically according to the real time math waveform.

Default Scale: The scale is reset to default.

16.2 Configuring with the All Channel Setup Menu

This section explains how to set the real time math source waveform settings on all channels.

Items Common to Scope Mode and Recorder Mode

- Turning real time math on and off
- Label
- Real time math expression
- Math source waveforms, coefficients

[“Real Time Math \(/G03, /G05 option\)” in the Features Guide](#)

All Channel Setup Menu

1. On the waveform screen’s **MENU**, tap **CH > All CH**, or press **ALL CH**. An all channel setup menu appears.
2. Tap **RealTime Math**, or press the soft key. The following screen appears.

Turning real time math on or off

Set the label.

Set the expression.

Set the math source waveform and coefficients.
(The settings vary depending on the expression.)

	Input	Label	Operation	Sin Ch	Cos Ch	Carrier Ch
1	<input checked="" type="checkbox"/>	RTmath1	Resolver	CH6_1	CH6	CH1
2	<input checked="" type="checkbox"/>	RTmath2	Rotary Angle	CH7	CH7	
3	<input checked="" type="checkbox"/>	RTmath3	Knock Filter	CH1		
4	<input checked="" type="checkbox"/>	RTmath4	RMS	CH1		
5	<input checked="" type="checkbox"/>	RTmath5	A(S1)B(S2)C	CH1	CH2	1.0000 1.0000
6	<input checked="" type="checkbox"/>	RTmath6	Rotary Angle	CH7		
7	<input type="checkbox"/>	RTmath7				
8	<input type="checkbox"/>	RTmath8				

Note

Not all real time math items can be set on the all channel setup menu. For items that cannot be set, use the real time math menu.

Chapter 17

Power Math (/G5 option)

Main Control Areas Used in This Chapter

You can also use the touch panel.

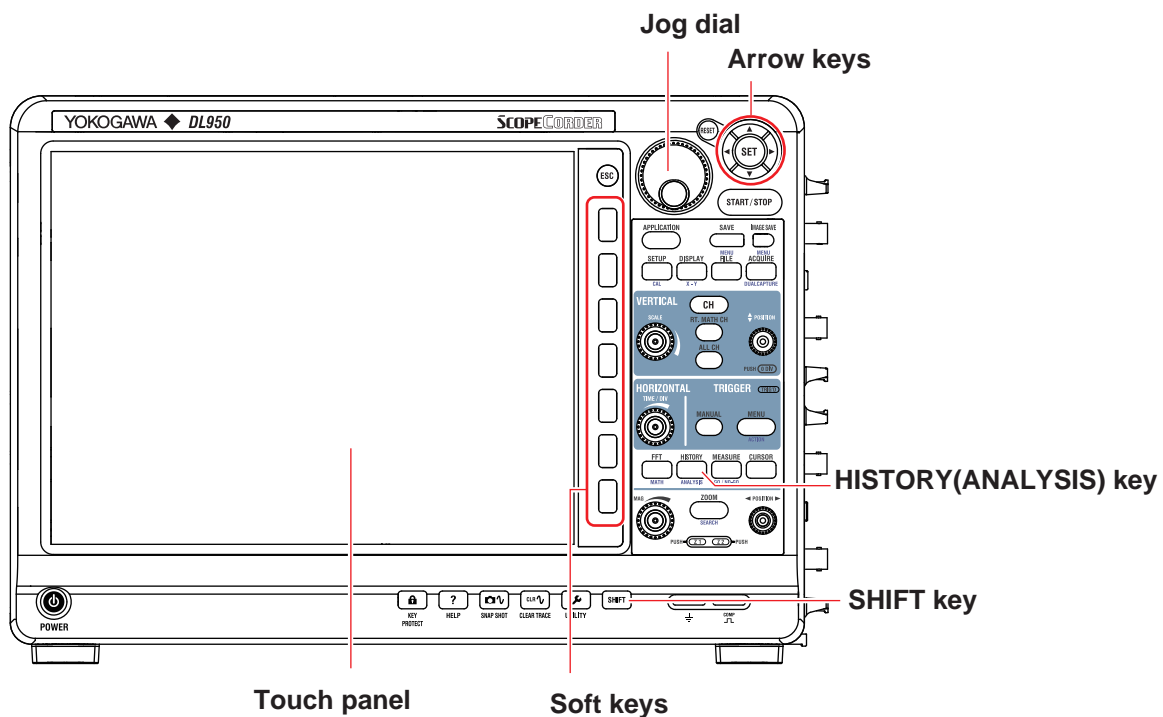

Operation Modes Applicable to the Sections in This Chapter

✓: Applicable, -: Not applicable

Section	Scope Mode	Recorder Mode
17.1 Power Analysis (Power)	✓	✓
17.2 Harmonic Analysis (Harmonics)	✓	✓

* The settings may vary depending on the operation mode.

17.1 Power Analysis (Power)

This section explains the following settings for performing power analysis:

Items Common to Scope Mode and Recorder Mode

- Power analysis mode
- Selecting power analysis items
- Power analysis reset

▶ [“Power Math \(/G05 option\)” in the Features Guide](#)

Power Analysis Menu (Power)

1. On the waveform screen’s **MENU**, tap **ANALYSIS** > **ANALYSIS**, or press **SHIFT+HISTORY (ANALYSIS)**.
2. Tap **Power**, or press the soft key. A power analysis menu appears.

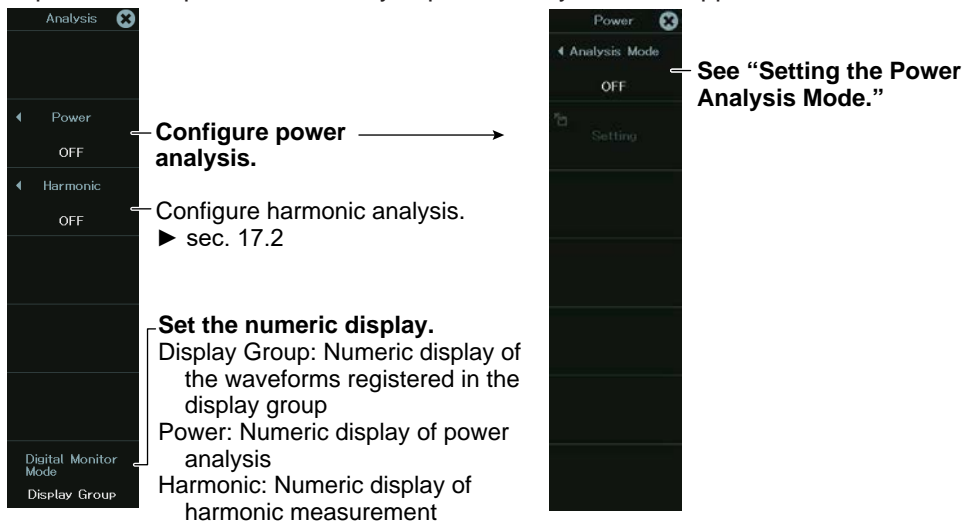

Setting the Power Analysis Mode (Analysis Mode)

3. Tap **Analysis Mode**, or press the soft key. The following screen appears.
Set the analysis mode.

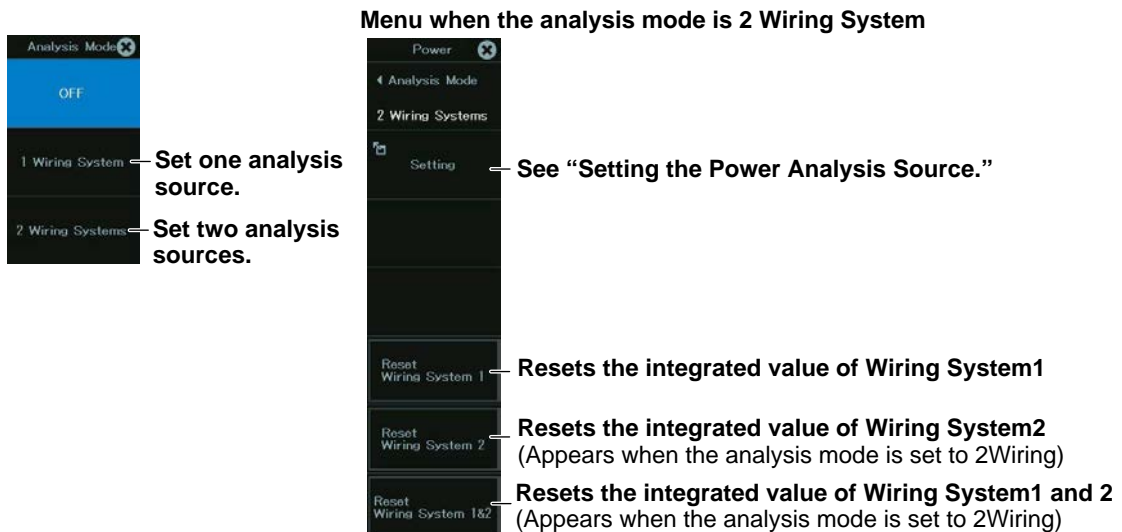

Setting the Power Analysis Source

4. Tap **Setting**, or press the soft key. The following screen appears.

Select the math source waveform.

Set the wiring system (1P2W, 1P3W, 3P3W, 3V3A, 3P4W, 3P3W→3V3A, 3V3A→3P4W, 3P4W→3V3A).

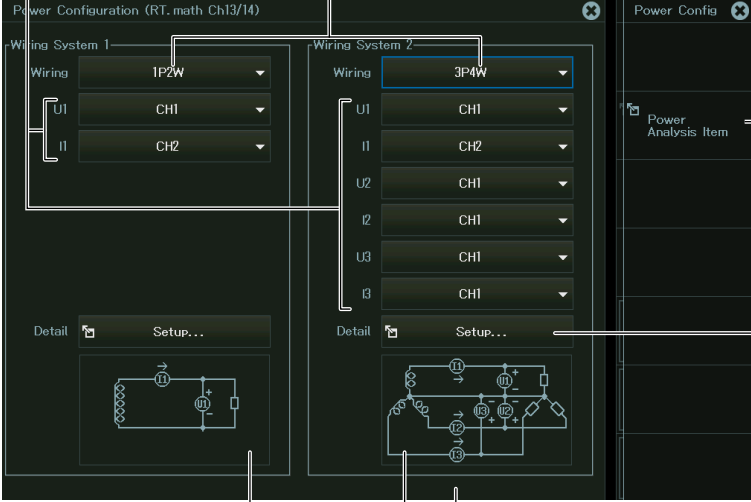

See "Selecting Power Analysis Items."

See "Detail Setup."

Wiring diagram

Wiring System 2 is displayed when the analysis mode is 2 Wiring System.

Detail Setup (Detail)

5. Tap **Detail**, or select **Detail** using the jog dial or arrow keys, and press **SET**. The following screen appears.

When the Calculation Period Type Is Set to Edge

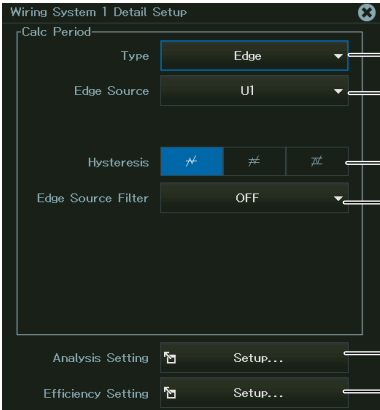

Set the calculation period type to Edge.

Set the edge detection source* (U1 to U3, I1 to I3, Other Channel, Own U, Own I).

Set the hysteresis (\sphericalangle , \neq , \sphericalangle).

Set the edge source filter (OFF, 128kHz, 64kHz, 32kHz, 16kHz, 8kHz, 4kHz, 2kHz, 1kHz, 500Hz, 250Hz, 125Hz, 62.5Hz).

See "Analysis Setting."

See "Efficiency Setting."

* The source types that you can select vary depending on the wiring system. Other Channel can be specified when the wiring system is 1P2W. Own U and Own I can be specified when the wiring system is not 1P2W.

17.1 Power Analysis (Power)

When the Calculation Period Type Is Set to Timer

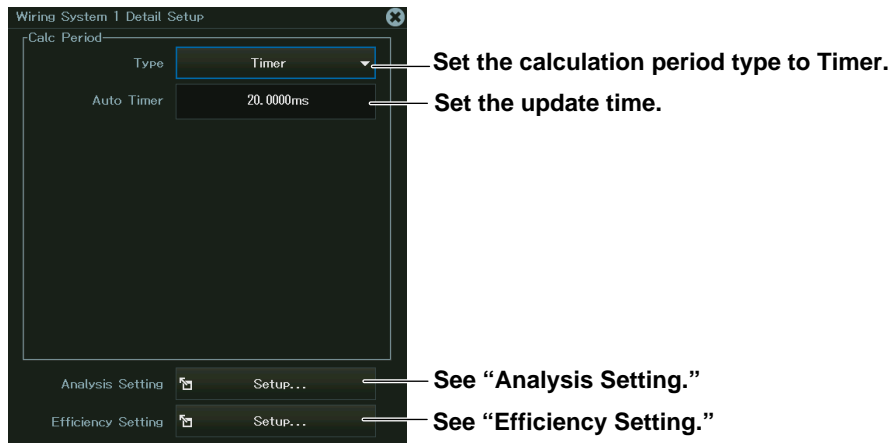

When the Calculation Period Type Is Set to Transient

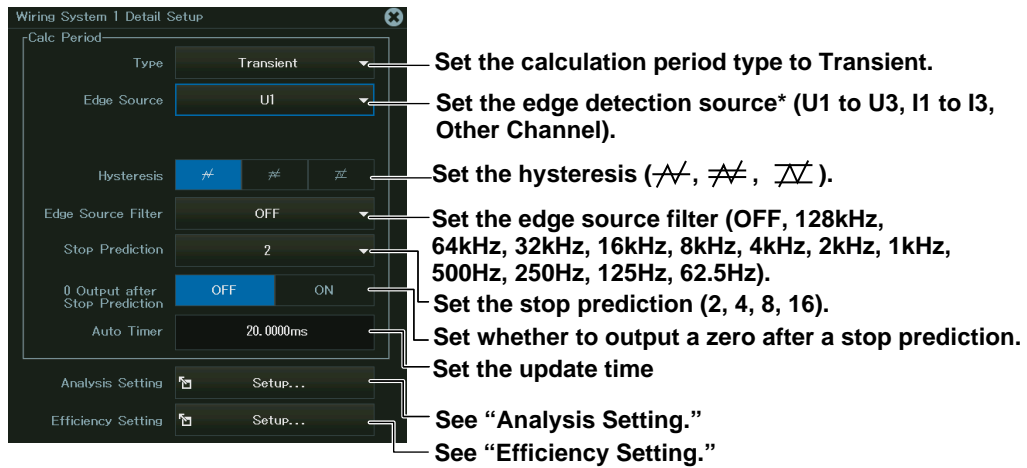

* The source types that you can select vary depending on the wiring system. Other Channel can be specified when the wiring system is 1P2W.

Analysis Setting (Analysis Setting)

6. Tap **Setup** next to **Analysis Setting**, or select **Setup** next to **Analysis Setting** using the jog dial or arrow keys, and press **SET**. The following screen appears.

Wiring System 1 Analysis Setup

RMS Type: True RMS, Rect. Mean

Φ Scale (\times): Radian, Degree

Load circuit connection type: Series, Parallel

(*) : Common to Both Wiring Systems

Integration Setup

Condition: All times, In Acquisition

Reset on Start: OFF, ON

Scaling: Second, Hour

Annotations:

- Select the RMS type (True RMS, Rect. Mean).
- Select the ϕ scale (Radian, Degree).
- Set the load circuit connection type (Series, Parallel).
- Set the integration condition (All times, In Acquisition).
- Set reset-at-start (OFF, ON).
- Set the scaling (Second, Hour).

Efficiency Setting (Efficiency Setting)

6. Tap **Setup** next to **Efficiency**, or select **Setup** next to **Efficiency** using the jog dial or arrow keys, and press **SET**. The following screen appears.

When the Efficiency Mode Is Set to Power

Wiring System 1 Efficiency Setup

Mode: Power

$\eta = (\#2_P\Sigma / \#1_P\Sigma) \times 100 (\%)$

Annotation: Set the efficiency mode (OFF, Power, Motor).

When the Efficiency Mode Is Set to Motor

Wiring System 1 Efficiency Setup

Mode: Motor

$\eta = (P_m / \#1_P\Sigma) \times 100 (\%)$

Pm Setup

Pm Type: RotationAngle, Speed

$P_m = K \times \text{RotationAngle} \times \text{Torque}$

K: 1.000

RotationAngle: RTmath1

Scaling: 0° ~ 360°

Torque: CHI

Annotations:

- Set the efficiency mode (OFF, Power, Motor).
- Set the Pm type (rotating speed type) (RotationAngle, Speed).
- Set coefficient K.
- Set the channel used to derive the rotating speed.
- Set the scaling (rps, rpm).
- Set the channel used to derive the torque.

Selecting Power Analysis Items (Power Analysis Item)

5. Tap **Power Analysis Item**, or press the soft key. The following screen appears. Display example when the analysis mode is set to 1 Wiring Systems and the wiring system is set to 1P2W

Output items

Urms1 Irms1 Udc1 ldc1
 Uac1 Iac1 P1 S1
 Q1 λ1 φ1 fU1
 fll U+pk1 U-pk1 I+pk1
 I-pk1 P+pk1 P-pk1 WP1
 WP+1 WP-1 q1 q+1
 q-1 WS1 WQ1 Z1
 R1 X1 Pm n
 Time

Set all output items to OFF (clear the check boxes).
 Set all output items to ON (select the check boxes).

See "Setting All Output Items."

- Display example when the analysis mode is set to 2 Wiring Systems and the wiring system is set to 1P2W

Output items

Urms1 Irms1 Udc1 ldc1
 Uac1 Iac1 P1 S1
 Q1 λ1 φ1 fU1
 fll U+pk1 U-pk1 I+pk1

Urms1 Irms1 Udc1 ldc1
 Uac1 Iac1 P1 S1
 Q1 λ1 φ1 fU1
 fll U+pk1 U-pk1 I+pk1

Set all output items to OFF (clear the check boxes).
 Set all output items to ON (select the check boxes).

See "Setting All Output Items."

Setting All Output Items

Analysis items (scroll to display hidden items)

	Color	Label	Upper limit	Lower limit
1	■	#1_Urms1	5.0000V	-5.0000V
2	■	#1_Irms1	5.0000A	-5.0000A
3	■	#1_Udc1	5.0000V	-5.0000V
4	■	#1_idc1	250.00A	-250.00A
5	■	#1_Uac1	250.00V	-250.00V
6	■	#1_Iac1	250.00A	-250.00A
7	■	#1_P1	25.000kW	-25.000kW
8	■	#1_S1	25.000kVA	-25.000kVA
9	■	#1_Q1	25.000kvar	-25.000kvar
10	■	#1_Lamb1	0.001k	-1.0000
11	■	#1_PHI1	0.180kdeg	-180.00deg

Setup	Description
Wiring System 1	Switches the displayed wiring system
Wiring System 2	
All AutoScale	Sets all upper limits and lower limits using auto scale.
All DefaultScale	Sets all upper limits and lower limits to their default values.

17.2 Harmonic Analysis (Harmonics)

This section explains the following settings for performing harmonic analysis:

- Harmonic analysis mode
- Selecting harmonic analysis items
- Harmonic analysis window

► [“Power Math \(/G05 option\)” in the Features Guide](#)

Harmonic Analysis Menu (Harmonic)

1. On the waveform screen’s **MENU**, tap **ANALYSIS** > **ANALYSIS**, or press **SHIFT+HISTORY (ANALYSIS)**. The following menu appears.
2. Tap **Harmonic**, or press the soft key. A harmonic analysis menu appears.

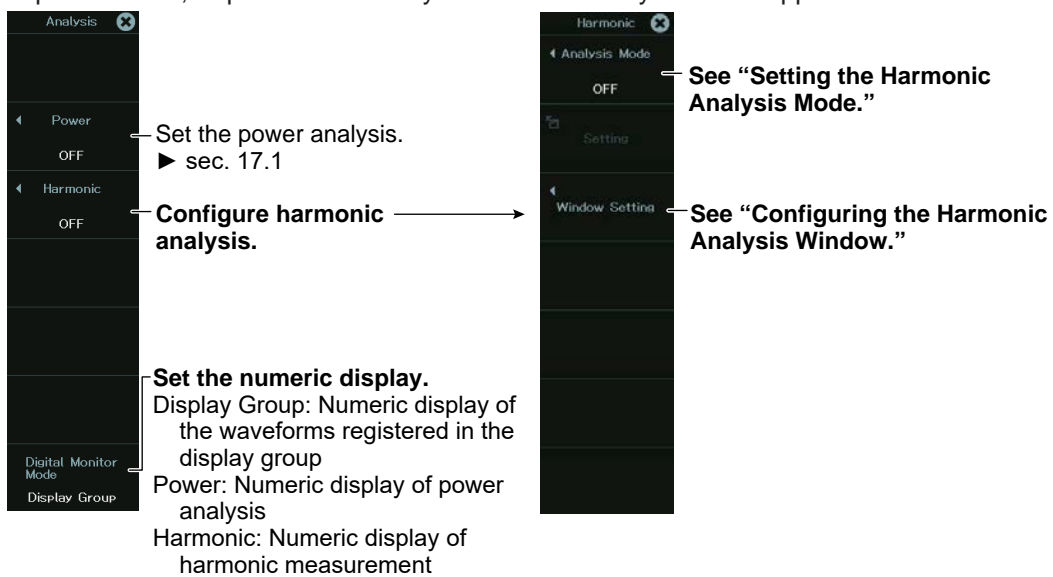

Setting the Harmonic Analysis Mode (Analysis Mode)

3. Tap **Analysis Mode**, or press the soft key. The following screen appears.
 Set the analysis mode.

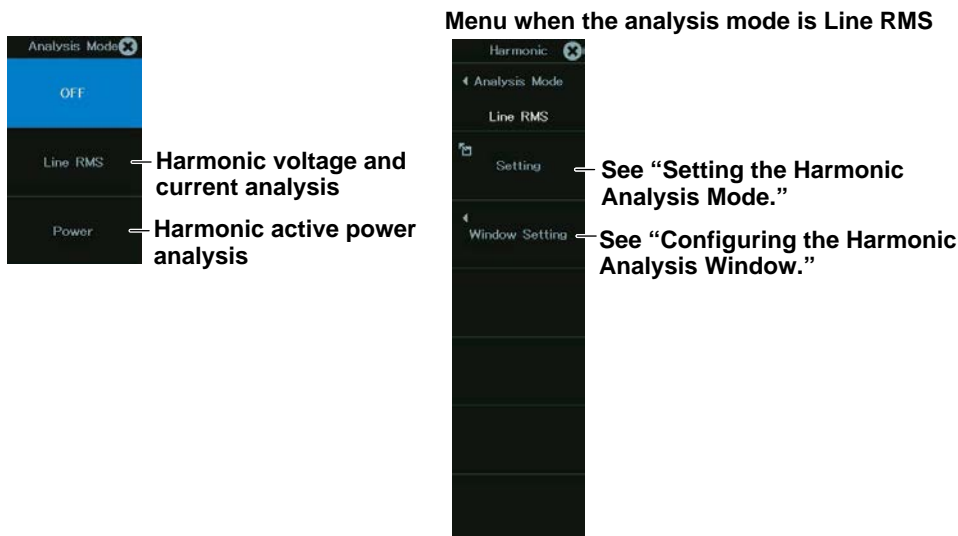

When Analysis Mode is set to Line RMS (voltage/current harmonic analysis)

Selecting the Harmonic Analysis Mode (Harmonic)

4. Tap **Setting**, or press the soft key. The following screen appears.

Edge detection source (same as the math source waveform)
Select the math source waveform.

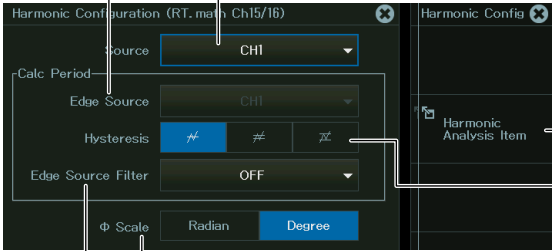

Select the ϕ scale.

Set the edge source filter (OFF, 128kHz, 64kHz, 32kHz, 16kHz, 8kHz, 4kHz, 2kHz, 1kHz, 500Hz, 250Hz, 125Hz, 62.5Hz).

See "Selecting Harmonic Analysis Items."
 Set the hysteresis (∇ , ∇ , ∇).

Selecting Harmonic Analysis Items

5. Tap **Harmonic Analysis Item**, or press the soft key. The following screen appears.

Output items



See "Setting All Output Items."

Sets all output items to on (selects the check boxes) or off (clears the check boxes)

Resets settings to their defaults.

Collectively sets ϕ (1 to 35) to on or off
 Collectively sets Rhdf(1 to 35) to on or off
 Collectively sets Rms(1 to 35) to on or off

Setting All Output Items

Analysis items (scroll to display hidden items)

	Color	Label	Upper limit	Lower limit
All Items Output Setup ✕				
	Analysis Item	Label	Upper	Lower
1	RMS(x)		0.0000	0.0000
2	RMS(1)	RMS(1)	5.0000	-5.0000
3	RMS(2)	RMS(2)	5.0000	-5.0000
4	RMS(3)	RMS(3)	5.0000	-5.0000
5	RMS(4)	RMS(4)	5.0000	-5.0000
6	Rhdf(x)		0.0000	0.0000
7	Φ(x)		0.0000	0.0000
8	RMS	RMS	5.0000	-5.0000
9	THDIEC	THDIEC	5.0000	-5.0000
10	THDCSA	THDCSA	5.0000	-5.0000

Tap “+” or move the cursor to “+” and press SET to display the items that have been set to ON when harmonic analysis items were selected. “+” changes to “-”.

When Analysis Mode is set to Power

Setting the Harmonic Analysis Mode (Harmonic)

4. Tap **Setting**, or press the soft key. The following screen appears.

Select the math source waveform (the items vary depending on the wiring system).

Set the wiring system (1P2W, 1P3W, 3P3W, 3V3A, 3P4W, 3P3W→3V3A, 3V3A→3P4W, 3P4W→3V3A).

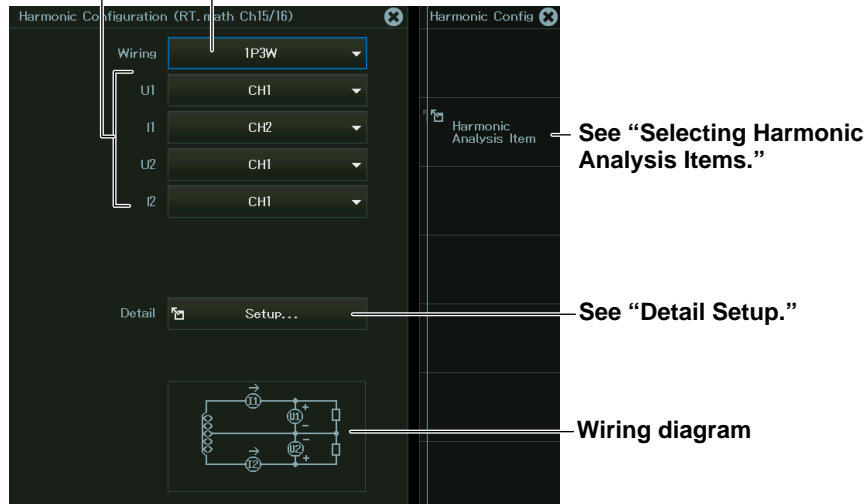

Detail Setup (Detail)

5. Select **Setup** to display the following screen.

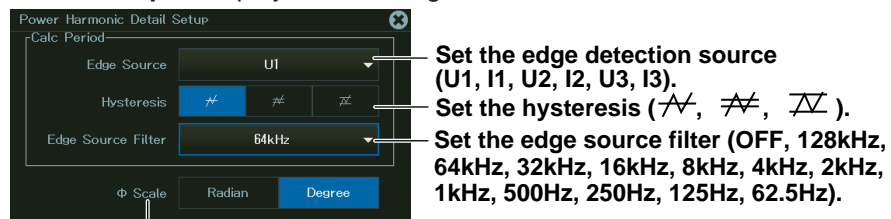

Select the ϕ scale.

Selecting Harmonic Analysis Items (Harmonic Analysis Item)

6. Tap **Harmonic Analysis Item**, or press the soft key. The following screen appears.

Output items

See “Setting All Output Items.”

Sets all output items to on (selects the check boxes) or off (clears the check boxes)

Resets settings to their defaults.

Collectively sets $\phi(1$ to $35)$ to on or off

Collectively sets Phdf(1 to 35) to on or off

Collectively sets P(1 to 35) to on or off

Setting All Output Items (All Output Items Setup)

7. Tap **All Output Items Setup**, or press the soft key. The following screen appears.

Analysis items (scroll to display hidden items)

	Color	Label	Upper limit	Lower limit
All Items Output Setup				
Analysis Item		Label	Upper	Lower
1	-	P(x)	0.0000	0.0000
2		P(1)	5.0000	-5.0000
3		P(2)	5.0000	-5.0000
4		P(3)	5.0000	-5.0000
5		P(4)	5.0000	-5.0000
6		P(5)	5.0000	-5.0000
7	+	Phdf(x)	0.0000	0.0000
8	+	$\phi(x)$	0.0000	0.0000
9		P	5.0000	-5.0000
10		S	5.0000	-5.0000
11		Q	5.0000	-5.0000

Tap “+” or move the cursor to “+” and press SET to display the items that have been set to ON when harmonic analysis items were selected. “+” changes to “-”.

Configuring the Harmonic Analysis Window (Harmonic Window Setup)

Setting the Display Type (Type)

3. Tap **Window Setting**, or press the soft key.
4. Tap **Type**, or press the soft key.

From the menu that appears, select the display type.

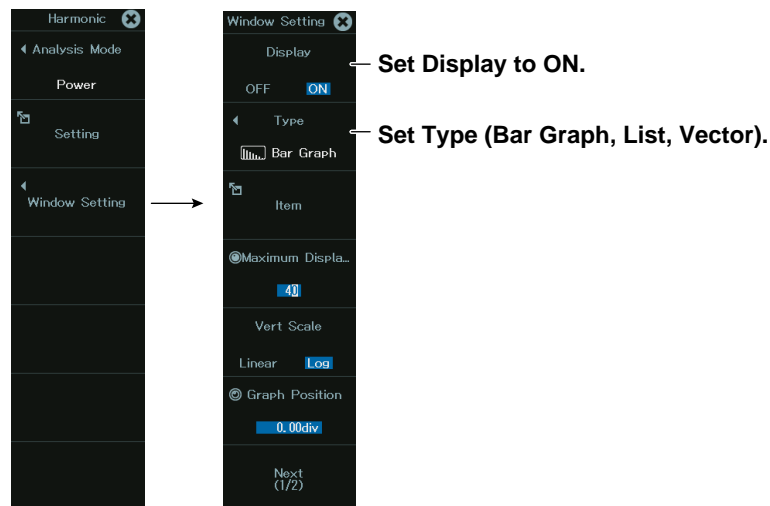

There are three methods to display the harmonic analysis results.

- Bar graph (Bar): A bar graph is displayed for the calculated harmonic value of each harmonic up to the 40th harmonic.
- List (List): A numerical list is displayed for the calculated harmonic value of each harmonic up to the 40th harmonic.
- Vector (Vector): The relationship of the phase difference and size (rms value) between the fundamental waves U(1) and I(1) of the element is displayed with vectors.

Configuring the Bar Graph (Bar Graph)

Window setup menu (1/2)

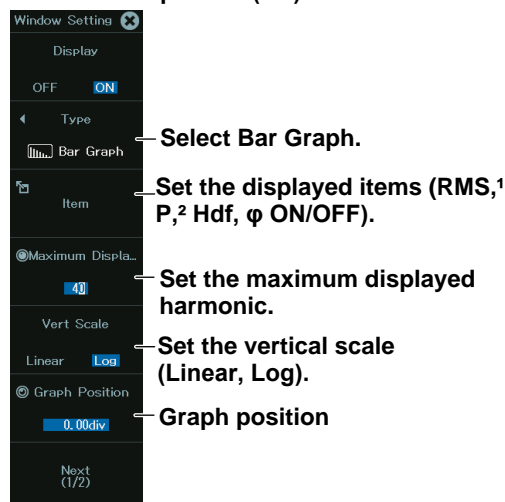

Window setup menu (2/2)

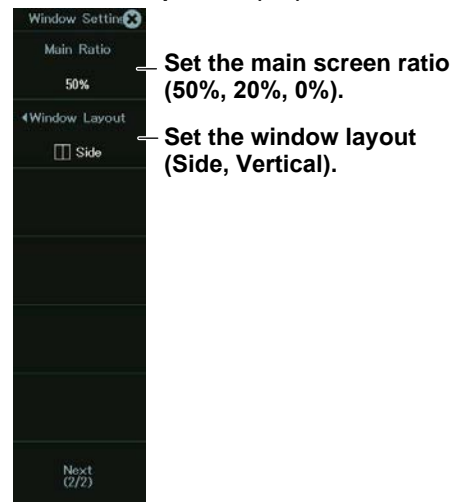

- 1: When the analysis mode is Line RMS
- 2: When the Analysis Mode is Power

Configuring the List (List)

Window setup menu (1/2)

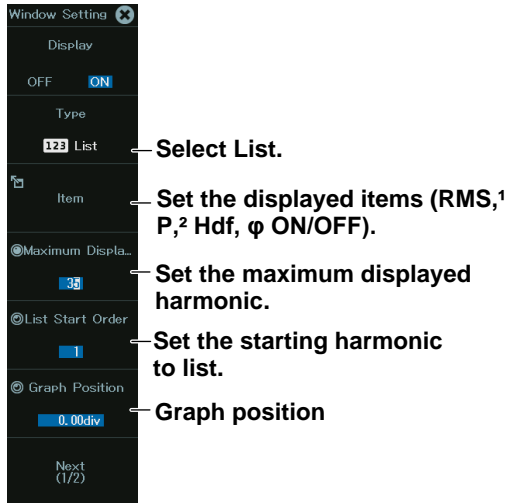

Window setup menu (2/2)

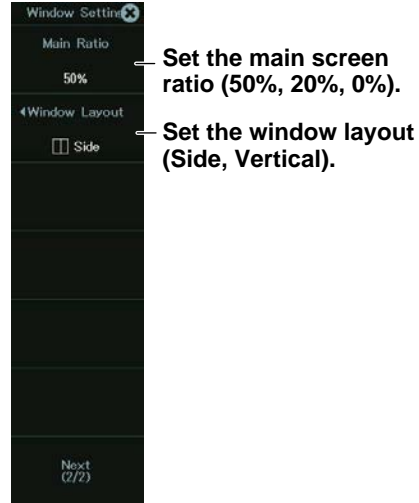

- Select List.
- Set the displayed items (RMS,¹ P,² Hdf, φ ON/OFF).
- Set the maximum displayed harmonic.
- Set the starting harmonic to list.
- Graph position

- 1: When the analysis mode is Line RMS
- 2: When the Analysis Mode is Power

Configuring the Vector (Vector)

You can configure this when Analysis Mode is set to Power.

Window setup menu (1/2)

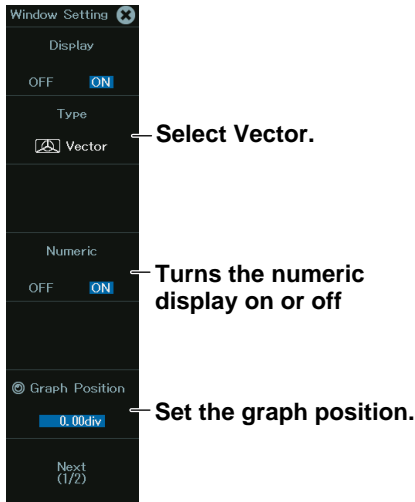

Window setup menu (2/2)

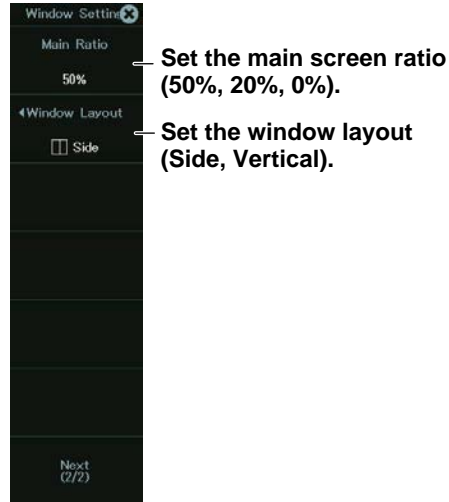

- Select Vector.
- Turns the numeric display on or off
- Set the graph position.
- Set the main screen ratio (50%, 20%, 0%).
- Set the window layout (Side, Vertical).

Chapter 18

Printing and Saving Screen Captures

Main Control Areas Used in This Chapter

You can also use the touch panel.

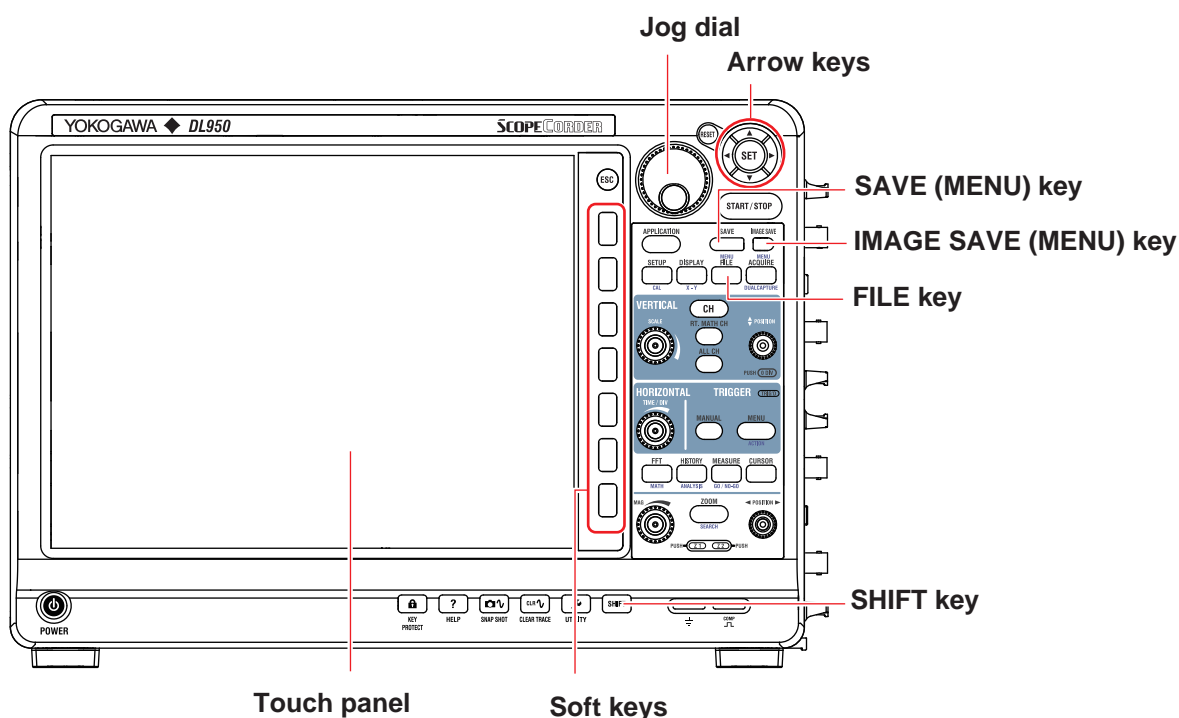

Operation Modes Applicable to the Sections in This Chapter

✓: Applicable, -: Not applicable

Section	Scope Mode	Recorder Mode
18.1 Printing on a Network Printer	✓	✓
18.2 Printing on a USB Printer	✓	✓
18.3 Saving Screen Captures to Files	✓	✓

* The settings may vary depending on the operation mode.

18.1 Printing on a Network Printer

This section explains the following settings for printing images displayed on the instrument on a network printer:

Items Common to Scope Mode and Recorder Mode

- Print destination
- Printer type
- Color
- Comment

► “Printing on a Network Printer (Network Print)” and “Printing and Saving Screen Captures (IMAGE SAVE key)” in the Features Guide

IMAGE SAVE Menu

1. On the waveform screen’s **MENU**, tap **FILE > IMAGE SAVE MENU**, or press **SHIFT+IMAGE SAVE (MENU)**. The following screen appears.

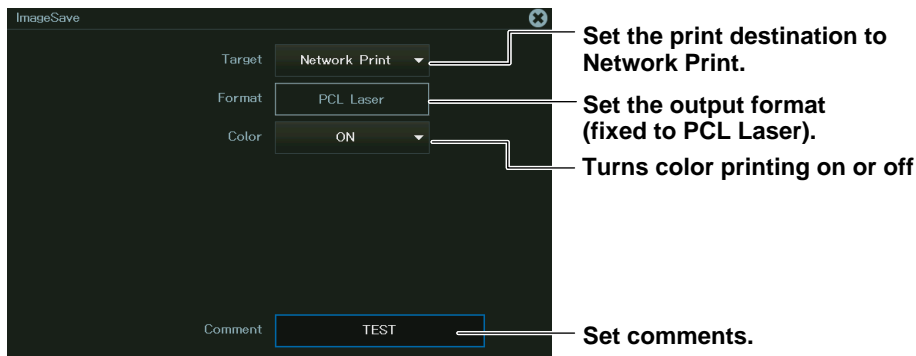

Note

You must configure the network printer in advance by following the instructions in section 20.8.

Printing

2. Press **IMAGE SAVE** to print the image that is displayed on the screen using a network printer.

18.2 Printing on a USB Printer

This section explains the following settings for printing images displayed on the instrument on a USB printer:

Items Common to Scope Mode and Recorder Mode

- Print destination
- Printer type
- Color
- Comment

► “Printing on a USB Printer (USB Print)” and
“Printing and Saving Screen Captures (IMAGE SAVE key)” in the Features Guide

IMAGE SAVE menu

1. On the waveform screen’s **MENU**, tap **FILE > IMAGE SAVE MENU**, or press **SHIFT+IMAGE SAVE (MENU)**. The following screen appears.

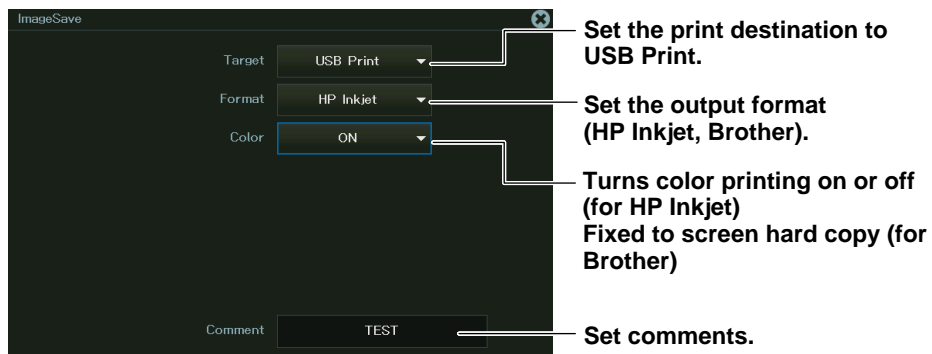

Printing

2. Press **IMAGE SAVE** to print the image that is displayed on the screen using a USB printer.

18.3 Saving Screen Captures to Files

This section explains the following settings for saving screen captures to files:

You can save screen captures to files in one of three ways: using the IMAGE SAVE menu, using the SAVE menu, or using the FILE menu.

Items Common to Scope Mode and Recorder Mode

- Print destination
- Data format
- Color data
- Background transparent or opaque
- Save destination and file name

► “Saving Screen Captures to Files (File),”
“Printing and Saving Screen Captures (IMAGE SAVE key),”
“Saving Other Types of Data (Others),”
and “Saving Data (SAVE key)” in the Features Guide

Using the IMAGE SAVE Menu

1. On the waveform screen’s **MENU**, tap **FILE > IMAGE SAVE MENU**, or press **SHIFT+IMAGE SAVE (MENU)**. The following screen appears.

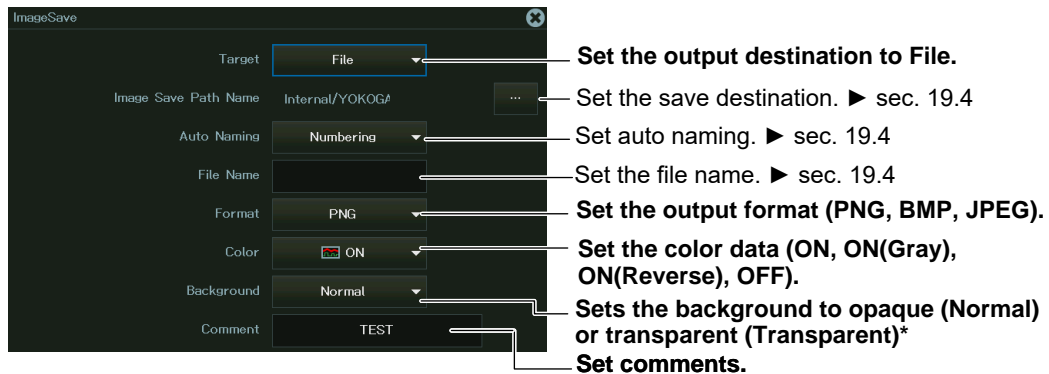

* This appears when the data format is set to PNG.

Saving

2. Press **IMAGE SAVE** to save the screen capture file to the specified folder.

Using the SAVE Menu

1. On the waveform screen's **MENU**, tap **FILE > SAVE MENU**, or press **SHIFT+SAVE (MENU)**. The following screen appears.

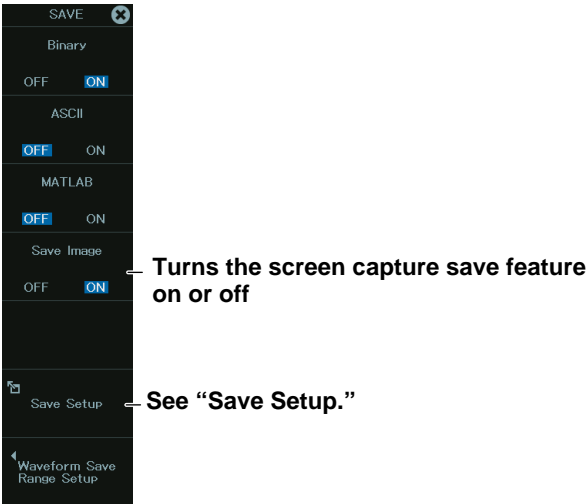

Save Setup (Save Setup)

2. Tap **Save Setup**, or press the soft key. The following screen appears.

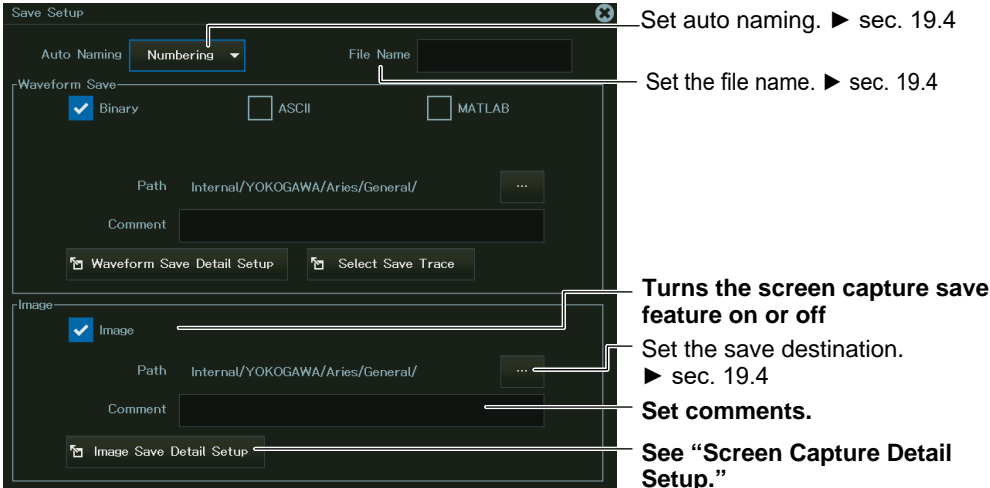

Screen Capture Detail Setup

3. Tap **Image Save Detail**, or select **Image Save Detail** using the jog dial or arrow keys, and press **SET**.

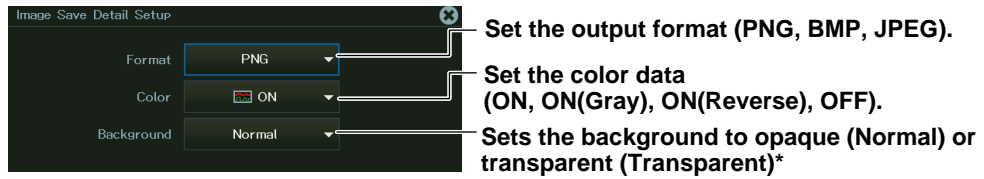

* This appears when the data format is set to PNG.

Saving

4. Press **SAVE** to save the screen capture file to the specified folder.
If Waveform Save on the SAVE menu is set to ON, the waveform data is also saved.

Using the FILE Menu

1. On the waveform screen's MENU, tap **FILE > FILE**, or press **FILE**. The following screen appears.

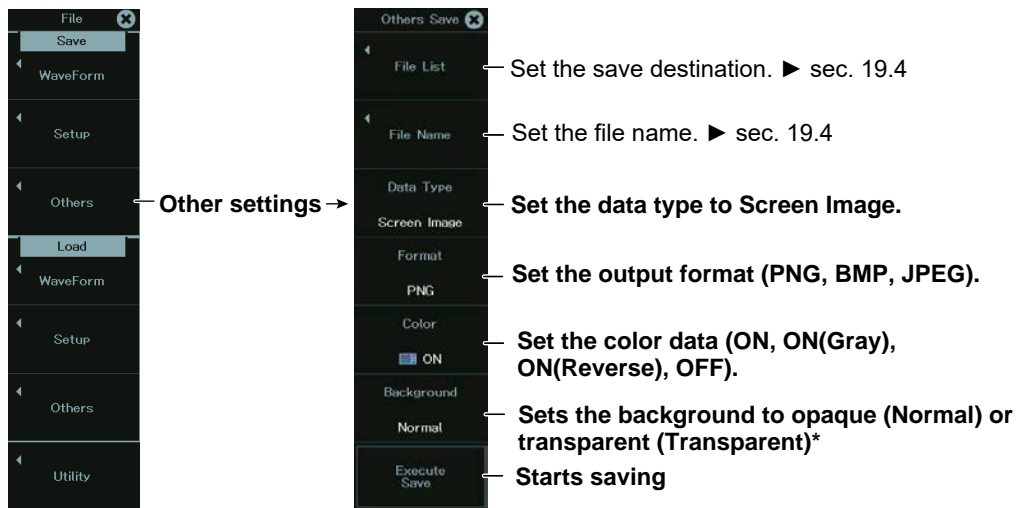

* This appears when the data format is set to PNG.

Saving

2. Tap **Execute Save**, or press the soft key.

Chapter 19

Saving and Loading Data

Main Control Areas Used in This Chapter

You can also use the touch panel.

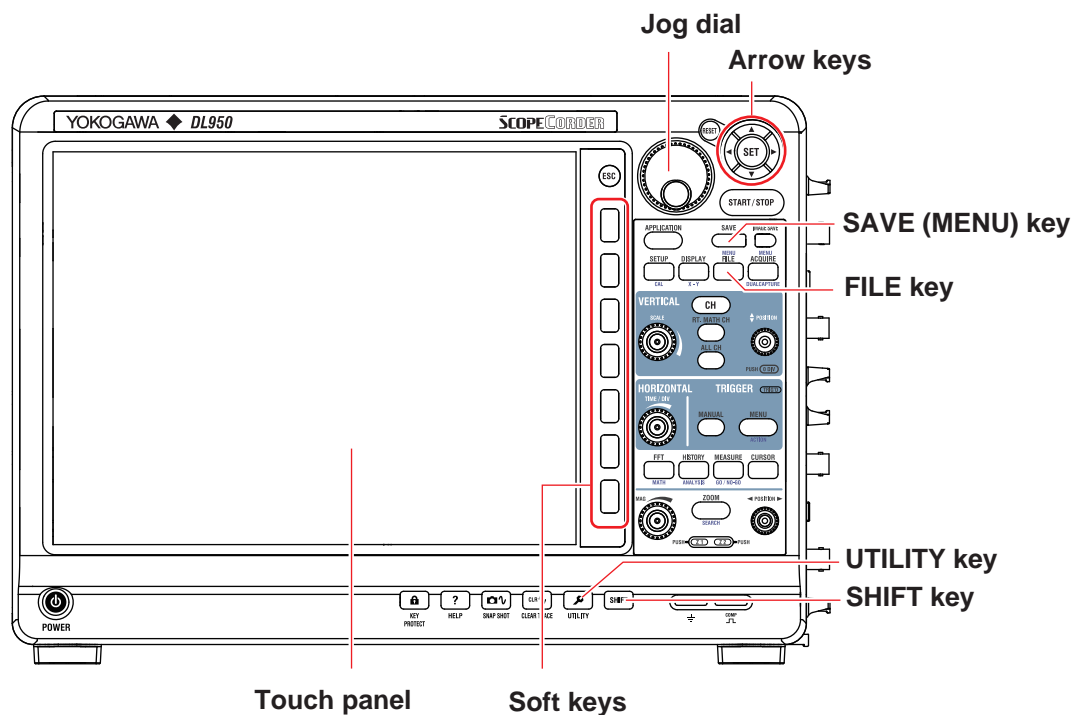

Operation Modes Applicable to the Sections in This Chapter

✓: Applicable, -: Not applicable

Section	Scope Mode	Recorder Mode
19.1 Connecting a Storage Device	✓	✓
19.2 Internal Storage (SSD) (/ST1 option)	✓	✓
19.3 Formatting a Storage Device	✓	✓
19.4 Saving Waveform Data	✓	✓
19.5 Saving Setup Data	✓	✓
19.6 Saving Other Types of Data	✓	✓
19.7 Loading Waveform Data	✓	✓
19.8 Loading Setup Data	✓	✓
19.9 Loading Other Types of Data	✓	✓
19.10 Performing File Operations	✓	✓

* The settings may vary depending on the operation mode.

19.1 Connecting a Storage Device

This section explains how to connect the following storage device for saving and loading data to the Instrument:

- SD memory card
- USB storage device

SD memory card



CAUTION

- Do not insert the SD memory card in the wrong direction. Doing so may damage the SD memory card and the instrument.
- Inserting and removing the SD memory card quickly (within the span of a second) may damage the instrument.
- Removing the SD memory card from the instrument while the card is being accessed may corrupt the data on the SD memory card.
- An icon  appears at the top center of the screen when the SD memory card is being accessed.

French



ATTENTION

- Ne placez pas la carte mémoire SD dans le mauvais sens et ne l'insérez pas en forçant dans le DL950. Vous risqueriez d'endommager la carte mémoire SD et le DL950.
- Le fait d'insérer et de retirer la carte mémoire SD rapidement (en une seconde) peut endommager le DL950.
- Le fait de retirer la carte mémoire SD du DL950 pendant que le dispositif accède à cette carte risque d'endommager les données qu'elle contient.
- Une icône() au centre de la partie supérieure de l'écran indique que le dispositif est en train d'accéder à la carte mémoire SD.

SD Memory Cards That Can Be Used

You can use memory cards that conform to the SD, SDHC, or SDXC standard with the instrument. For details, contact your nearest YOKOGAWA dealer.

Note

When using an SD memory card with a PC, make sure that the PC is compatible with the SD memory card. Also, depending on the type of PC, some of the SD cards listed above may not function properly. Check it in advance.

Inserting an SD Memory Card

Insert the SD memory card into the slot with the front of the card facing the front panel.

The SD memory card slot is on the left side panel of the instrument.

If you are using an SD memory card that has a write-protection feature and you want to save data to or format the card, disable the write-protection feature before you insert the SD memory card into the instrument.

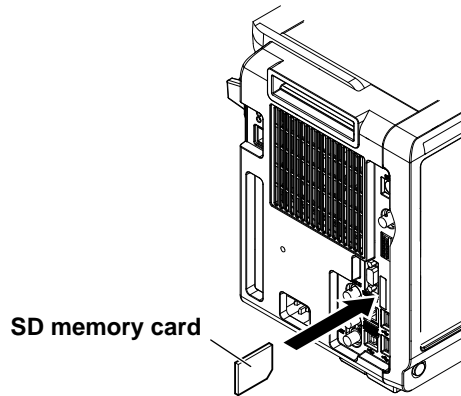

Removing the SD Memory Card

Press the edge of the SD memory card with your finger. Release the SD memory card to eject.

Remove the SD memory card.

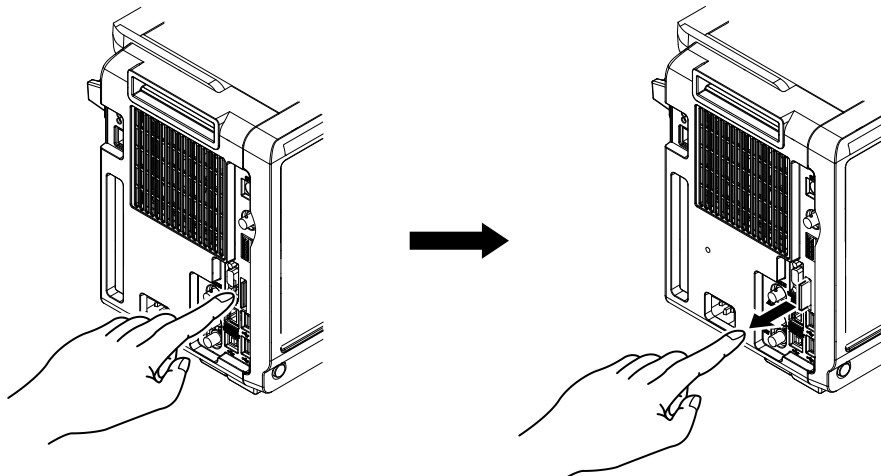

Push the card in.



Release the SD memory card to eject.

General SD Memory Card Handling Precautions

Follow the general handling precautions that are provided with your SD memory card.



USB storage device

CAUTION

- During SSD recording, the  icon blinks in the center of the screen. While this icon is blinking, do not insert a USB storage device into the USB port for connecting peripheral devices. Doing so may cause the instrument to malfunction or may corrupt the data that is being recorded to the SSD.
 - Do not remove the USB storage device or turn off the power when the medium is being accessed. If you do so, the data on the USB storage device may be corrupted.
 - An icon  appears at the top center of the screen when the USB storage device is being accessed.
-

French

ATTENTION

- Pendant l'enregistrement du SSD, l'icône clignote au centre de l'écran. Lorsque cette  icône clignote, ne connectez pas le support de stockage USB aux ports USB prévus à cet effet. Vous risqueriez de causer un dysfonctionnement du DL950 ou d'endommager les données en cours d'enregistrement sur le SSD.
 - Pendant que le dispositif accède au support de stockage USB, ne retirez pas ce dernier et ne mettez pas l'alimentation hors tension. Vous risqueriez d'endommager les données sur le support de stockage USB.
 - Une icône () au centre de la partie supérieure de l'écran indique que le dispositif est en train d'accéder au support de stockage USB.
-

Compatible USB Storage Devices

You can use USB storage devices that are compatible with USB Mass Storage Class version 1.1.

Note

- Only connect a USB keyboard, mouse, printer, or storage device to the USB port for peripherals.
 - The instrument can handle up to four storage devices. If the connected device is partitioned, the instrument treats each partition as a separate storage device.
 - Connect USB storage devices directly, not through a USB hub.
 - Do not connect and disconnect the two USB devices repetitively. Provide at least a 10-second interval between removal and connection.
-

How to Connect a USB Storage Device

When connecting a USB storage device to the instrument's USB port, connect the USB cable directly as shown in the figure below. You can connect/disconnect a USB cable at any time regardless of whether the instrument is on or off (hot-plugging is supported). Connect the type A connector of the USB cable to the instrument, and connect the type B connector to the USB storage device. If you connect a USB storage device when the power switch is on, the device becomes available for use after the instrument identifies it.

The instrument has two USB ports: USB-0 and USB-1. The port numbers are not fixed. The port where the first detected USB storage device is connected to becomes USB-0. The second detected USB storage device becomes USB-1.

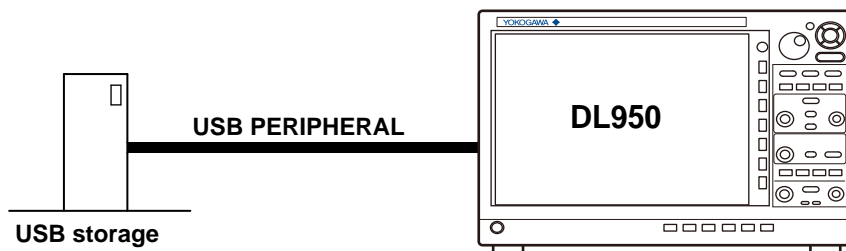

General USB Storage Device Handling Precautions

Follow the general handling precautions that are provided with your USB storage device.

19.2 Internal Storage (SSD) (/ST1 option)

This section explains the handling of the internal storage.



CAUTION

Do not store more than 513 files in the root directory of the internal storage. Doing so will slow the file access operations to all files. In addition, we cannot guarantee the operation of the storage device when the instrument is in this condition.

French



ATTENTION

Ne pas stocker plus de 512 fichiers dans le répertoire racine du SSD interne. Ceci ralentit les opérations d'accès à tous les fichiers. En outre, nous ne pouvons pas garantir le fonctionnement de la fonction d'enregistrement sur SSD lorsque le DL950 est dans cet état.

19.3 Formatting a Storage Device

This section explains how to format storage device.

- Storage management
- Formatting the storage device

► [“Formatting Storage Device \(Storage Manager\)”](#) in the [Features Guide](#)

CAUTION

- When you format a storage device, all the data on it is deleted.
- If a formatted storage device cannot be detected by the instrument, use the instrument to format the storage device again.

French

ATTENTION

- Lorsque vous formatez un support de stockage, toutes les données qu’il contient sont supprimées.
- Si le DL950 ne détecte pas un support de stockage formaté, utilisez le DL950 pour formater de nouveau le support de stockage.

System Config Menu

1. On the waveform screen’s **MENU**, tap **OTHERS** > **UTILITY**, or press **UTILITY**.
2. Tap **System Config**, or press the soft key. The following menu appears.

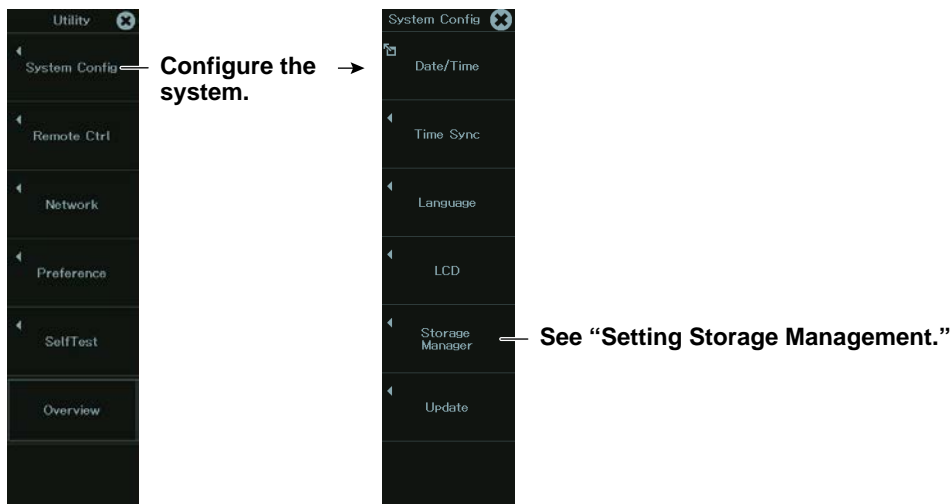

Setting Storage Management (Storage Manager)

3. Tap **Storage Manager**, or press the soft key. The following menu appears.



— Set the storage device to format (SSD, SD).

— Confirm that you want to format internal memory.

4. Tap **Execute Format**, or press the soft key. A format confirmation message appears. Selecting **OK** executes the format.

Storage Device That Will Be Formatted (Media)

SSD: Internal SSD

SD: SD memory card

19.4 Saving Waveform Data

This section explains the following settings for saving waveform data):

There are two methods to save files: using the FILE Waveform (Save) menu or using the SAVE menu.

Items Common to Scope Mode and Recorder Mode

- Save destination
- File name
- Data format
- Save range
- Waveform to save
- Saving waveform data

► [“Saving Waveform Data \(Waveform\)” in the Features Guide](#)

FILE Waveform (Save) Menu

1. On the waveform screen’s **MENU**, tap **FILE > FILE**, or press **FILE**.
2. Tap **Waveform** under Save, or press the soft key. The following screen appears.

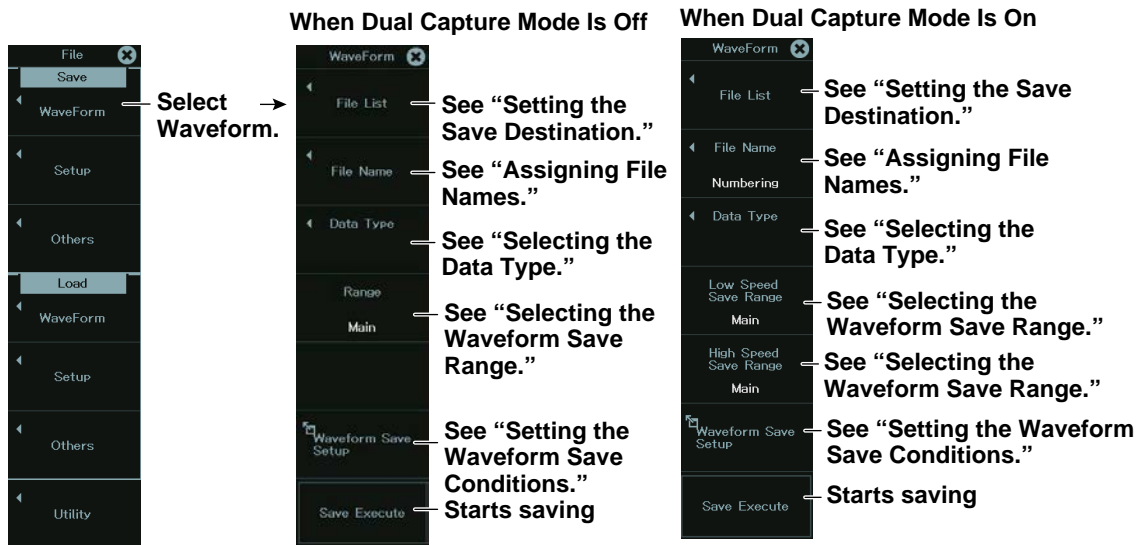

Setting the Save Destination (File List)

3. Tap **File List**, or press the soft key. The following screen appears.

Save destination drive (storage device) or folder
Use the jog shuttle or the up and down arrow keys (▲▼) to move the cursor, and press SET to make your selection.

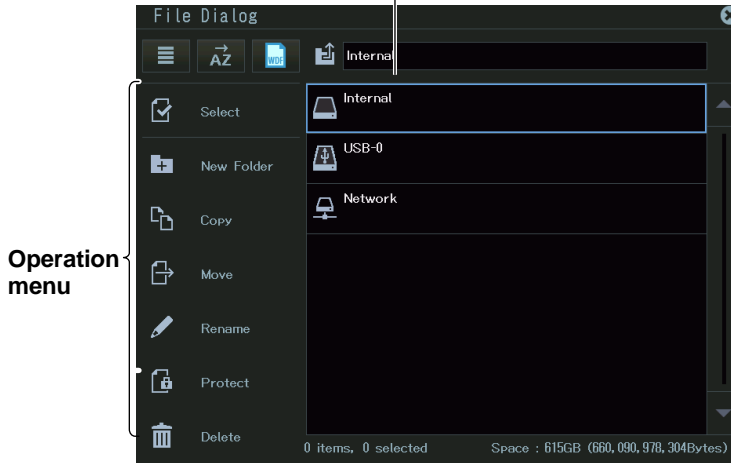

For more information on file operations, see section 19.10.

Assigning File Names (File Name)

3. Tap **File Name**, or press the soft key. The following screen appears.

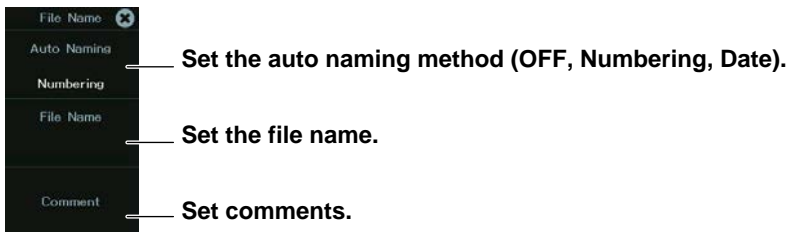

Note

- Auto naming, file name, and comment settings are shared (with SSD recording). The settings that you specify here will be applied to the SSD recording settings.
- When dual capture is on, “_HS” is appended to the file names of high-speed sampling and “_LS” to the file names of low-speed sampling.

Setting Auto Naming (Auto Naming)

OFF: The auto naming feature is disabled. The file name specified using the File Name setting is used. If there is a file with the same name in the save destination folder, you cannot save the data.

Numbering: A 4-digit serial number (0000 to 9999) is automatically appended to the common name (up to 32 characters) specified with the File Name setting.

Date: The file name is the date and time (down to ms) when the file is saved. The file name specified with the File Name setting is not used.

20200930_121530_100_000 (2020/09/30 12:15:30.100)

Year Month Day Hour Minute Second ms

Serial number (000 to 999) that is appended when a single file exceeds 2 GB

Regardless of whether the auto naming feature is set to OFF, Numbering, or Date, if the data size of a single file exceeds 2 GB, an underscore and a three-digit sequence number (000 to 999) is appended to the file name. The sequence number is incremented by one each time a file is added. This is appended only if the file exceeds 2 GB.

Setting a Comment (Comment)

You can add a comment that consists of up to 120 characters when you save a file. You do not have to enter a comment. All characters, including spaces, can be used in comments.

Selecting the Data Type (Data Type)

3. Tap **Data Type**, or press the soft key. The following screen appears.

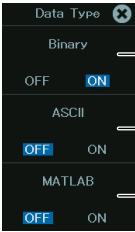
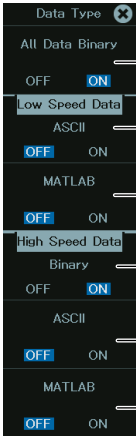
When Dual Capture Mode Is Off	When Dual Capture Mode Is On
 <p>Saves in binary format</p> <p>Saves in ASCII format</p> <p>Saves in MATLAB format</p>	 <p>Saves low-speed sampling and high-speed sampling waveform data to a file in binary format</p> <p>Saves low-speed sampling waveform data in ASCII format</p> <p>Saves low-speed sampling waveform data in MATLAB format</p> <p>Saves high-speed sampling waveform data in binary format</p> <p>Saves high-speed sampling waveform data in ASCII format</p> <p>Saves high-speed sampling waveform data in MATLAB format</p>

You can save the sampling data stored in the acquisition memory in the following data formats.

Data format	Extension	
Binary	.WDF	Data is saved in binary format. You can load this type of data into the instrument. ► sec. 19.7 Data can be saved in compressed form. For details, see the next page.
ASCII	.CSV	Data is scaled using the specified range and saved to a file in ASCII format. You cannot load this type of data into the instrument.
MATLAB	.MAT	Data is saved in MATLAB format. You cannot load this type of data into the instrument. Waveforms measured using the dual capture feature cannot be saved.

Note

If the data format is ASCII or MATLAB and the combination of the record length and the number of channels causes the file size to exceed 2 GB, the file cannot be saved.

Selecting the Waveform Save Range (Range)

3. Tap **Range**, or press the soft key.

When dual capture is on, tap **Low Speed Save Range** or **High Speed Save Range**, or press the soft key. The following screen appears.

Scope Mode

When Dual Capture Mode Is Off

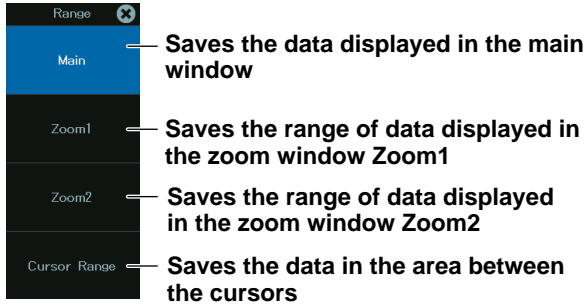

When Dual Capture Mode Is On

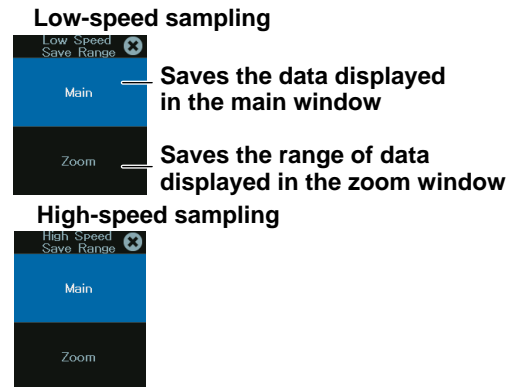

Recorder Mode

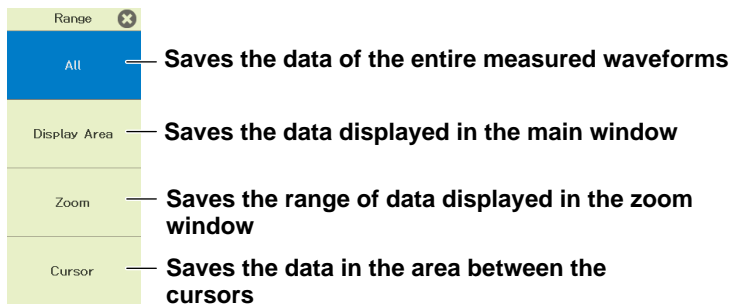

Selecting the Waveform to Save (Select Save Trace)

- You can select CH1 to CH16, 16CH TEMP/VOLT, CAN, CAN FD, LIN, SENT, or Math. The waveforms that are displayed are saved.
- If you set History to All, the Math waveforms will not be saved. If you want to save the Math data, set History to One.
- If you set History to All, all history waveforms within the range bounded by Start Record and End Record on the HISTORY menu will be saved. If you want to select which waveform will be saved, do not select All.

SAVE Menu

1. On the waveform screen’s **MENU**, tap **FILE > SAVE MENU**, or press **SHIFT+SAVE (MENU)**. The following screen appears.

When Dual Capture Mode Is Off

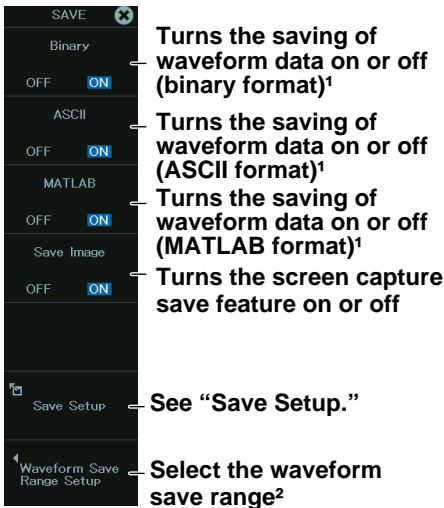

- Turns the saving of waveform data on or off (binary format)¹
- Turns the saving of waveform data on or off (ASCII format)¹
- Turns the saving of waveform data on or off (MATLAB format)¹
- Turns the screen capture save feature on or off

See “Save Setup.”

Select the waveform save range²

When Dual Capture Mode Is On

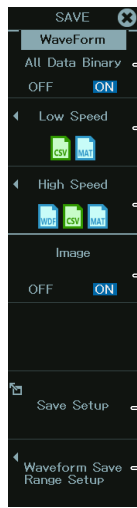

- Saves low-speed sampling and high-speed sampling waveform data to a file in binary format¹
- Turns saving of low-speed sampling waveform data on or off¹
- Turns saving of high-speed sampling waveform data on or off¹
- Turns the screen capture save feature on or off

See “Save Setup.”

Select the waveform save range²

- 1: This is the same as “Selecting a Data Type” of the FILE Menu.
- 2: This is the same as “Selecting the Waveform Save Range” of the FILE Menu.

Save Setup (Save Setup)

2. Tap **Save Setup**, or press the soft key. The following screen appears.

When Dual Capture Mode Is Off

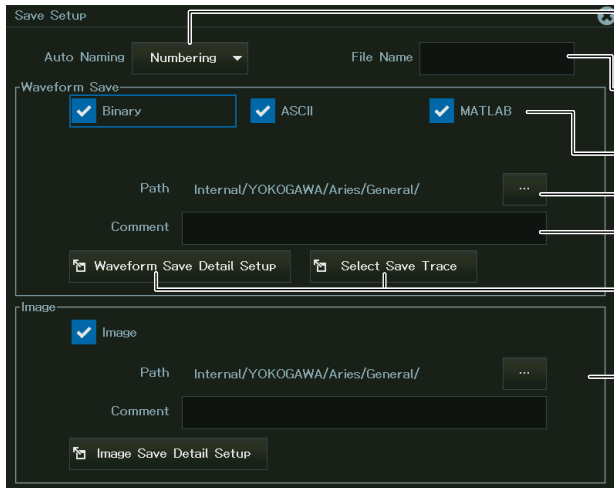

- Set auto naming. (This is the same as the setting on the FILE menu.)
- Set the file name. (This is the same as the setting on the FILE menu.)
- Set the format to save the data in.
- Set the save destination.
- Set comments.
- Set the waveform save conditions. (This is the same as the setting on the FILE menu.)
- Saves screen capture data ▶ sec. 18.3

When Dual Capture Mode Is On

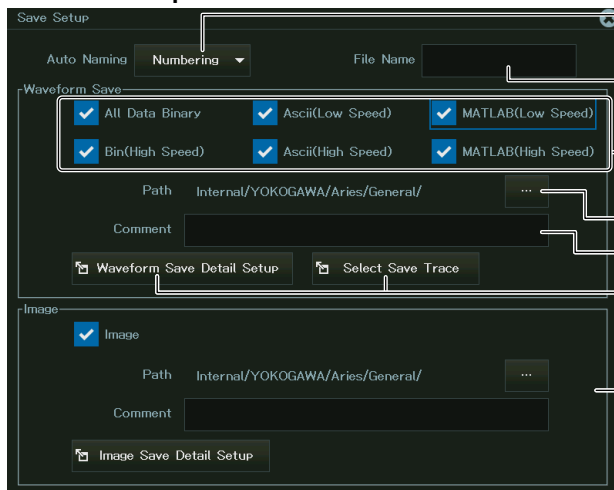
**Set auto naming.**

(This is the same as the setting on the FILE menu.)

Set the file name.

(This is the same as the setting on the FILE menu.)

Set the format to save the data in.**Set the save destination.****Set comments.****Set the waveform save conditions.**

(This is the same as the setting on the FILE menu.)

Saves screen capture data
▶ sec. 18.3

Saving

3. Press **SAVE**. When the saving is complete, a message appears. Tap **Close**, or press **SET**.

The waveform data file is saved in the specified folder. If Image Save on the SAVE menu is set to ON, the screen capture data is also saved.

Saving Waveform Data Using the SSD Recording or Action Feature

You can also save waveform data by using the SSD recording or action feature.

With SSD recording, waveform data is saved using the save destination and file name set here.

With the action feature, you can set the data type separately, but when SSD recording is on, the action feature is not available.

For details on SSD recording, see section 3.5. For details on the action feature, see section 15.1.

19.5 Saving Setup Data

This section explains the following settings for saving setup data: You can save setup data to a file.

Items Common to Scope Mode and Recorder Mode

- Save destination
- File name
- Saving setup data

► “Saving Setup Data (setup)” in the Features Guide

FILE Setup (Save) Menu

1. On the waveform screen’s **MENU**, tap **FILE > FILE**, or press **FILE**.
2. Tap **Setup** under Save, or press the soft key. The following screen appears.

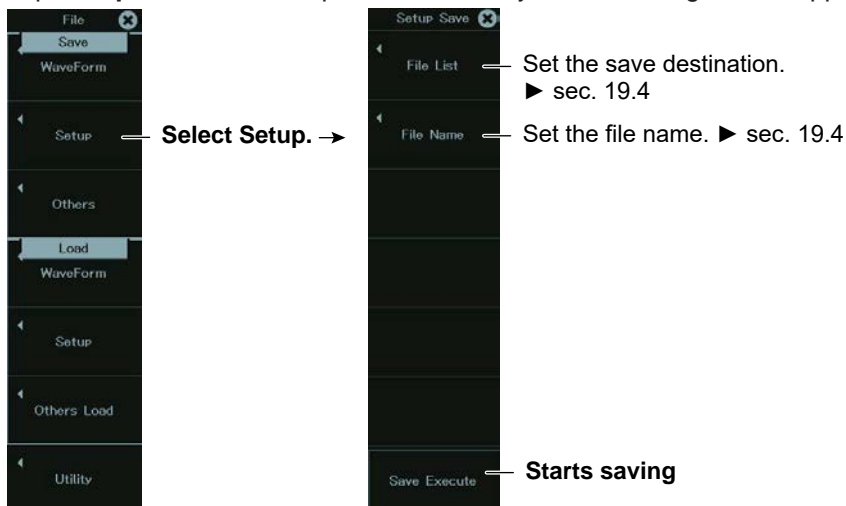

Saving Setup Data (Save Execute)

- You can save the setup data (the setup information of each key at the time that the file is saved) to a file. The extension is .SET.
- The date, time, and communication setup parameters are not saved.
- You cannot save setup data during waveform acquisition. Press START/STOP to stop the waveform acquisition.

19.6 Saving Other Types of Data

This section explains the following settings for saving screen captures, snapshot waveform data, results of automated measurement of waveform parameters, and results of FFT:

Items Common to Scope Mode and Recorder Mode

- Save destination
- File name
- Saved data
- Data type (screen captures)
- Color data (screen captures)
- Saving data

► “Saving Other Types of Data (Others)” in the Features Guide

FILE Others (Save) Menu

1. On the waveform screen's **MENU**, tap **FILE > FILE**, or press **FILE**.
2. Tap **Others** under Save, or press the soft key. The following screen appears.

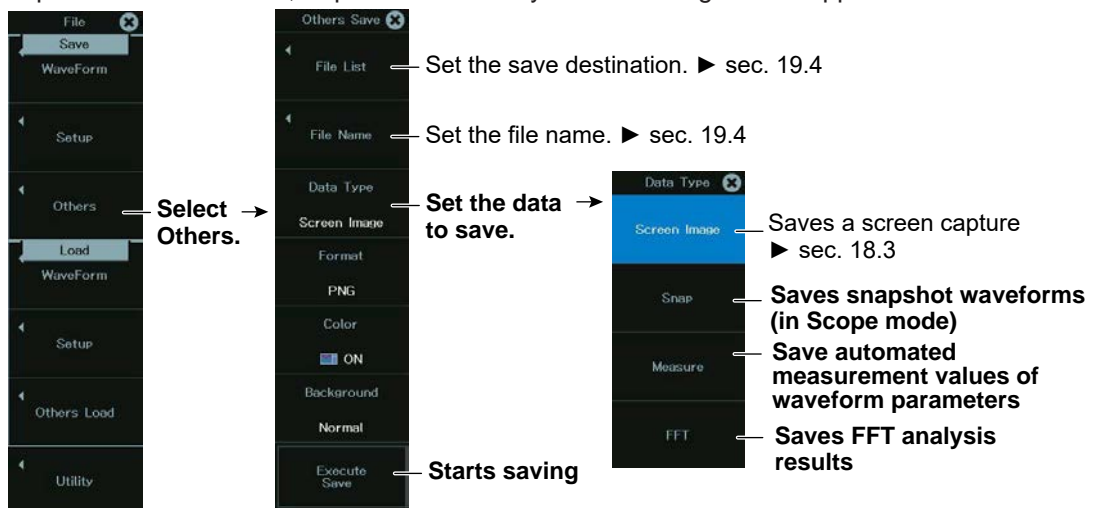

Setting the Data Type to Save (Data Type)

Screen Image: Save the display to a PNG, BMP, or JPEG file.

Snap: You can save the waveform data captured in a snapshot. The extension is .SNP. This is valid in Scope mode.

Measure: Save the results of automatic waveform parameter measurement to a file in CSV format.

FFT: You can save FFT analysis results to a file in CSV format.

When Data Type Is Snap (Scope mode)

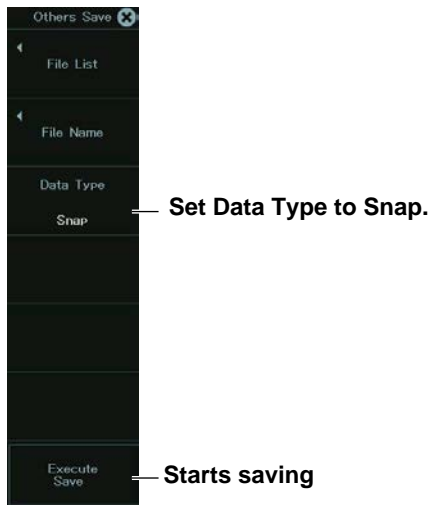

When Data Type Is Measure

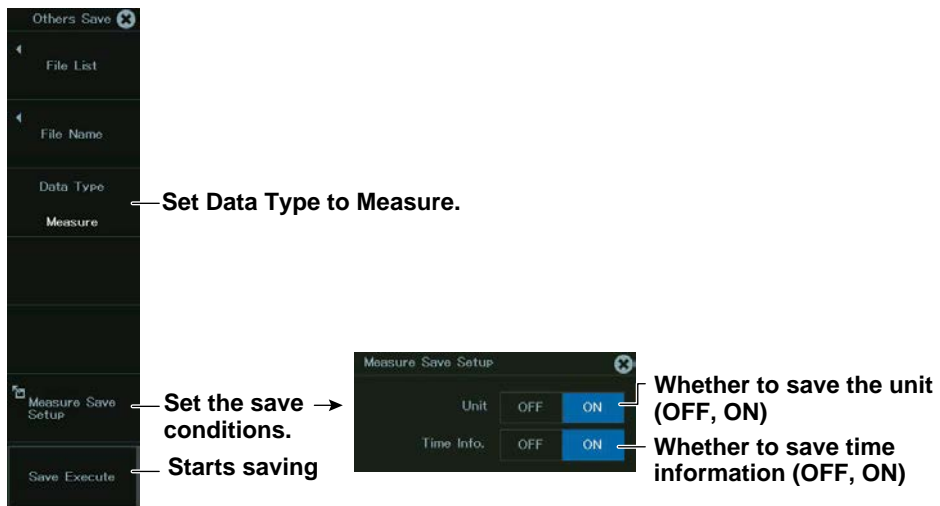

When Data Type Is FFT

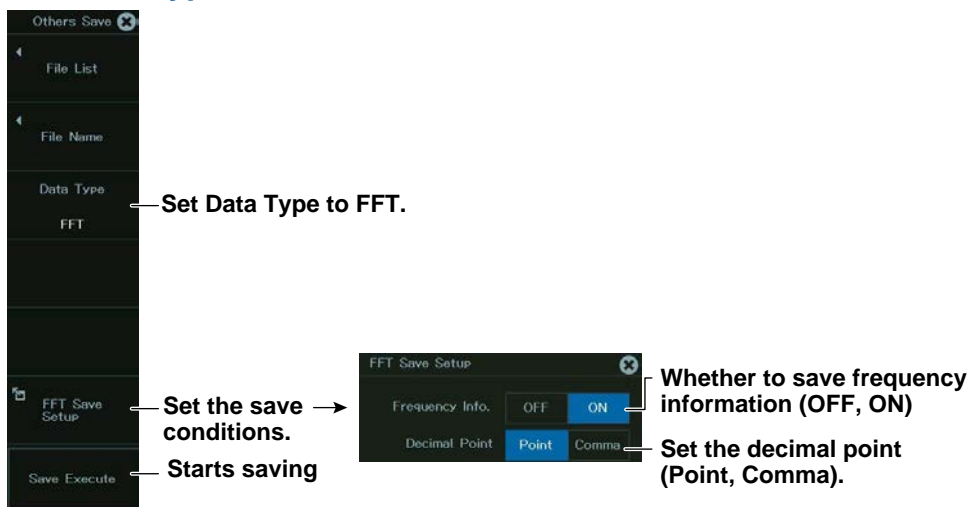

19.7 Loading Waveform Data

This section explains the following settings for loading waveform data:

Items Common to Scope Mode and Recorder Mode

- Displaying file information
- Loading into channels

► “Loading Waveform Data (Waveform)” in the Features Guide

FILE Waveform (Load) Menu

1. On the waveform screen’s **MENU**, tap **FILE > FILE**, or press **FILE**.
2. Tap **Waveform** under Load, or press the soft key. The following screen appears.

Select the .WDF file that you want to load.



Selecting a File

Select the file to load from the file list. For details on file operations, see section 19.10.

Loading Waveform Data (Load)

- The selected waveform data file is loaded together with the setup file. The extension is .WDF. Loaded data is cleared when you start measurement.
- If the module configuration when the waveform data is saved and that when the data is loaded are different, only the waveform data of modules that match is loaded. When loading is complete, a message indicating the channel numbers that were not loaded is displayed.

19.8 Loading Setup Data

This section explains the following settings for loading setup data:

Items Common to Scope Mode and Recorder Mode

- Displaying file information
- Loading setup data

► [“Loading Setup Data \(Setup\)” in the Features Guide](#)

FILE Setup (Load) Menu

1. On the waveform screen’s **MENU**, tap **FILE > FILE**, or press **FILE**.
2. Tap **Setup** under Load, or press the soft key. The following screen appears.

Select the **.SET** file that you want to load.

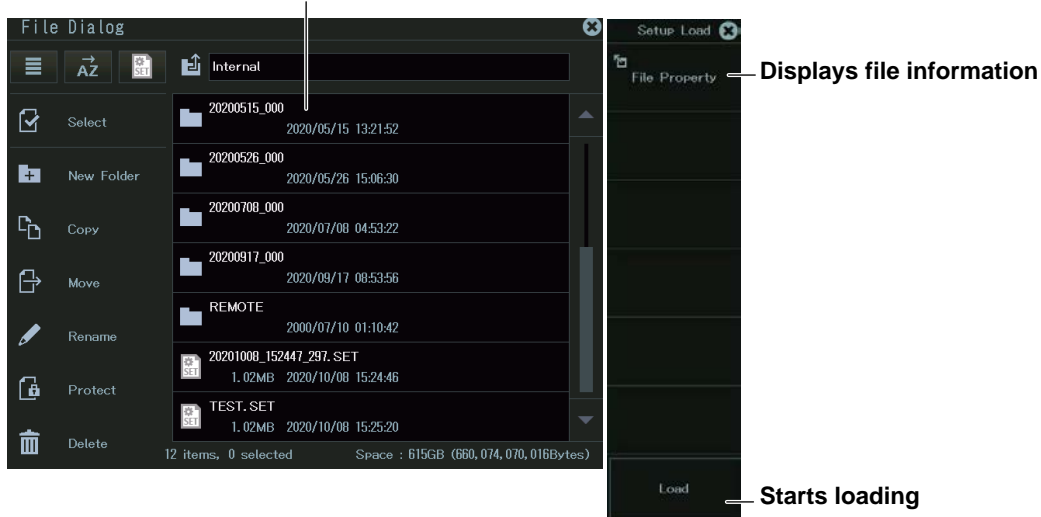

Selecting a File

Select the file to load from the file list. For details on file operations, see section 19.10.

Loading Setup Data (Load)

- Select the setup data and load it. The extension is **.SET**.
- If the module configuration when the setup data is saved and that when the data is loaded are different, only the setup data of modules that match is loaded. When loading is complete, a message indicating the channel numbers that were not loaded is displayed.

19.9 Loading Other Types of Data

This section explains the following settings for loading snapshot waveforms or symbol data:

Applicable in Scope Mode

- Displaying file information
- Data to load
- Loading data

Applicable in Recorder Mode

- Displaying symbol file information
- Load destination
- Loading files

► “Loading Other Types of Data (Others),” and “Loading Symbols (Symbol)” in the Features Guide

Scope Mode

FILE Others (Load) Menu

1. On the waveform screen’s **MENU**, tap **FILE > FILE**, or press **FILE**.
2. Tap **Others** under Load, or press the soft key. The following screen appears.

Select the file to load.

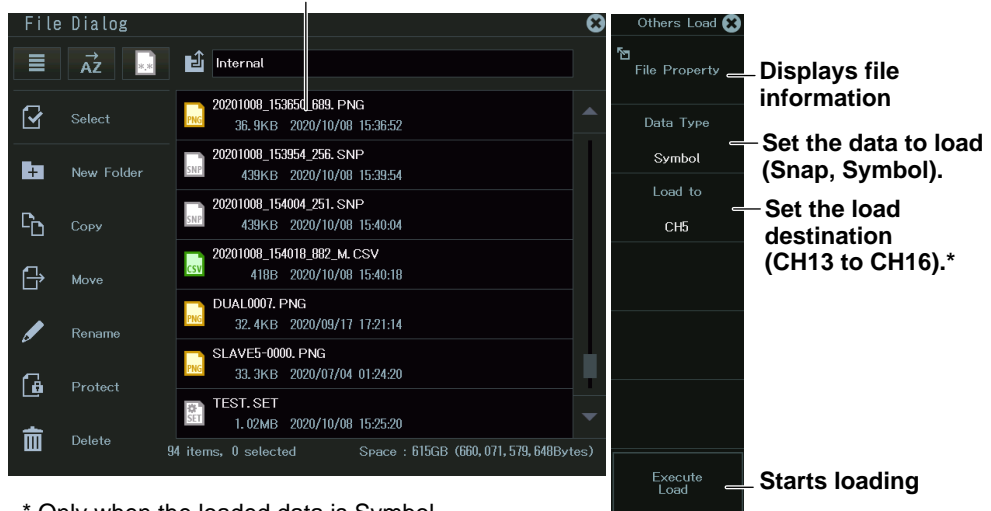

* Only when the loaded data is Symbol

Setting the Data Type to Load (Data Type)

Snap: A saved snapshot waveform is loaded. The extension is .SNP. This is valid in Scope mode.

Symbol: A CAN or CAN FD or LIN data definition file is loaded. The extension is .SBL. This is valid when a CAN bus monitor, CAN & LIN bus monitor, CAN/CAN FD monitor, or SENT monitor is installed.

Clearing the Waveform

To clear a loaded snapshot waveform, perform clear trace or initialize.

Recorder mode

FILE Symbol (Load) Menu

1. On the waveform screen's **MENU**, tap **FILE > FILE**, or press **FILE**.
2. Tap **Symbol** under Load, or press the soft key. The following screen appears.

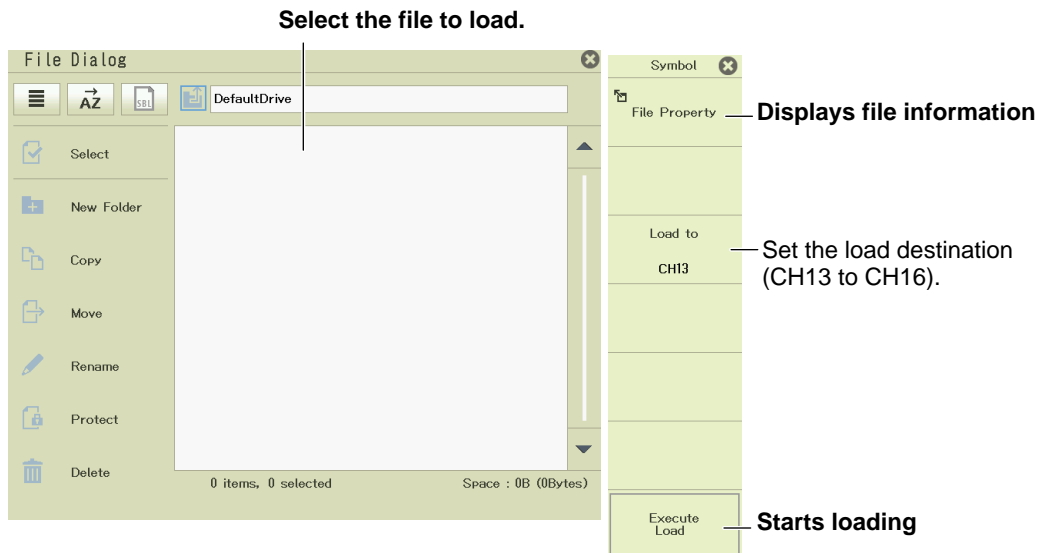

19.10 Performing File Operations

This section explains how to operate the file utility and file list.

Items Common to Scope Mode and Recorder Mode

- Creating folders
- Coping files and folders
- Moving files and folders
- Renaming files and folders
- Protecting files
- Deleting files and folders

► “File Operations (Utility)” in the Features Guide

File Utility (Utility)

1. On the waveform screen’s **MENU**, tap **FILE > FILE**, or press **FILE**.
2. Tap **Utility**, or press the soft key. The following screen appears.

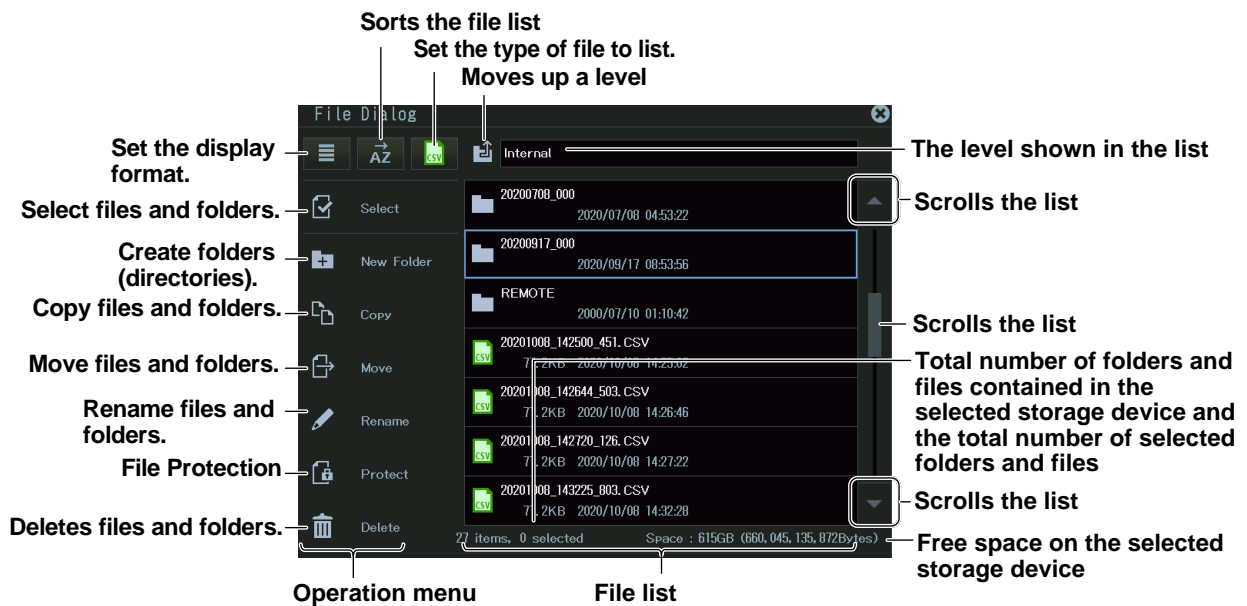

Note

The maximum number of files that can be shown in the file list is about 1000. This number varies depending on the storage device connection status and folder structure. It is possible to save files in a folder that contains more than 1000 files, but they may not appear in the file list. If this happens, delete some files or move them to another folder so that the number of files in the folder is less than about 1000 files.

Selecting Drives

Tap the folder icon several times to move to the top level. You can also move to the top level by moving the cursor to the folder icon with the jog dial or arrow keys and pressing SET.

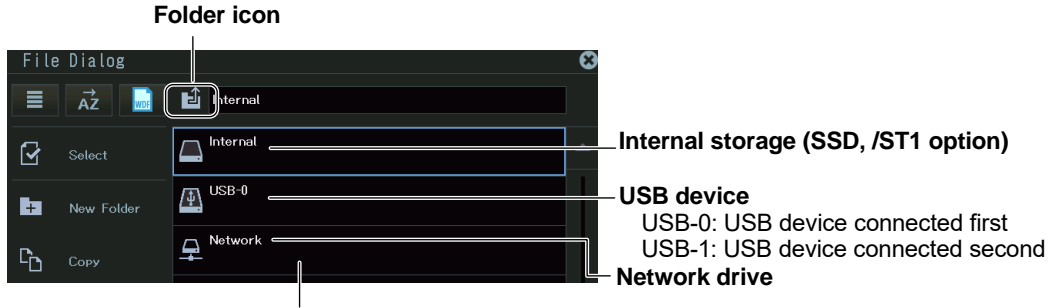

Select the drive.

Tap the drive, or use the jog shuttle or the up and down arrow keys (▲.▼) to move the cursor, and press SET to make your selection.

Setting the Display Format

Tap the display format icon to display the display format options. You can also display the options by moving the cursor to the display format icon with the jog dial or arrow keys and pressing SET.

Display format icon

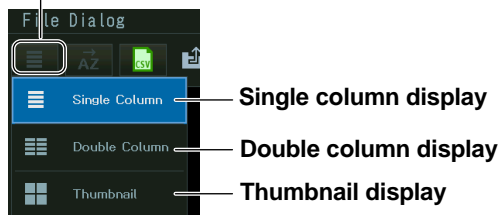

Sorting the File List

Tap the sort mode icon to display the sort mode options. You can also display the options by moving the cursor to the sort mode icon with the jog dial or arrow keys and pressing SET.

Sort method icon

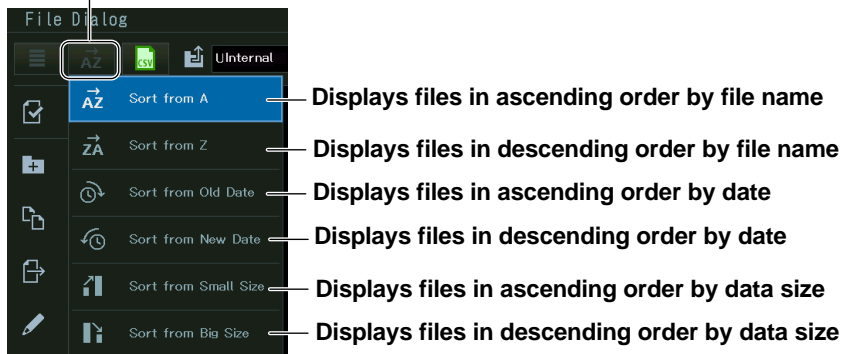

Selecting the Type of Files to List (Filter)

Tap file list type icon to display the file type list. You can also display the list by moving the cursor to the sort mode icon with the jog dial or arrow keys and pressing SET.

Icon of the type of files to list

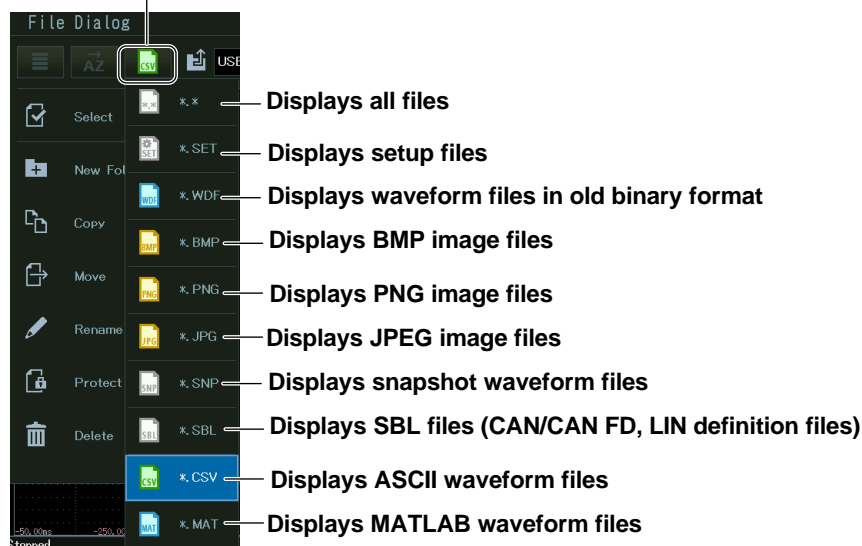

Selecting Files and Folders

Tap the file and folder selection icon to display the file and folder selection modes. You can also display the modes by moving the cursor to the file and folder selection icon with the jog dial or arrow keys and pressing SET.

Icon for selecting files and folders

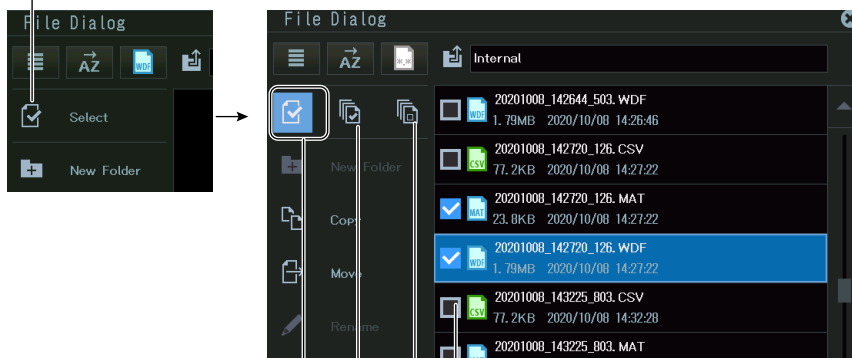

Check box

- Clears the check boxes from all files and folders
- Selects the check boxes of all files and folders
- Select the check boxes of files and folders one at a time.

Tap the check boxes to select files and folders. You can also select the file and folder check boxes by moving the cursor with the jog dial or arrow keys and pressing SET. File operations will be performed on the files and folders whose check boxes are selected.

Copying Files (Copy)

1. Select the file or folder that you want to copy from the file list.
2. On the operation menu, tap **Copy**, or move the cursor using the jog dial or arrow keys, and press **SET**. A copy destination selection screen appears.



3. Select the copy destination and tap **Copy**, or move the cursor using the jog dial or arrow keys, and press **SET**.

Moving Files (Move)

1. Select the file or folder that you want to move from the file list.
2. On the operation menu, tap **Move**, or move the cursor using the jog dial or arrow keys, and press **SET**. A move destination selection screen appears.

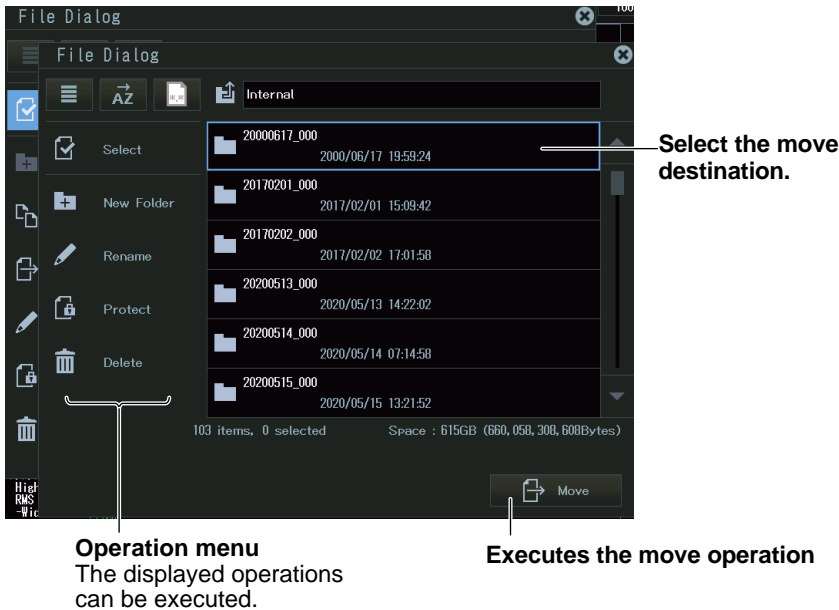

3. Select the move destination and tap **Move**, or move the cursor using the jog dial or arrow keys, and press **SET**.

Protecting Files

1. Select the file that you want to protect from the file list.
2. On the operation menu, tap **Protect**, or move the cursor using the jog dial or arrow keys, and press **SET**. A protection mark is added to the file icon.

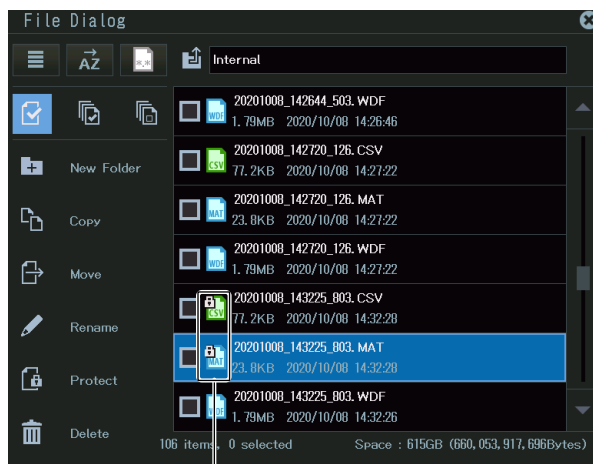

Protected files

Protection	File Attribute	Description
ON	r	The selected files are protected. The file can be read from. Writing is not allowed. Deleting is also not allowed.
OFF	r/w	The selected files are not protected. The file has read and write access.

Releasing the Protection

1. Select the file that you want to release the protection of from the file list.
2. On the operation menu, tap **Protect**, or move the cursor using the jog dial or arrow keys, and press **SET**. The protection mark is disappears from the file icon.

Making Folders (New Folder)

1. Display the location to create a folder in the file list.
2. On the operation menu, tap **New Folder**, or move the cursor using the jog dial or arrow keys, and press **SET**. A keyboard appears.
3. Enter the folder name.

Deleting Files and Folders (Delete)

1. Select the file or folder that you want to delete from the file list.
2. On the operation menu, tap **Delete**, or move the cursor using the jog dial or arrow keys, and press **SET**. A confirmation screen appears.
3. Tap **OK**, or select **OK** using the arrow keys, and press **SET**. The selected files and folders will be deleted.

Note

You can abort (Abort) file deleting. However, files that are already being processed are not applicable.

Renaming Files and Folders (Rename)

1. Select a file or folder that you want to rename from the file list.
2. On the operation menu, tap **Rename**, or move the cursor using the jog dial or arrow keys, and press **SET**. A keyboard appears.
3. Enter the new file name or folder name.

Chapter 20

Ethernet Communication

Main Control Areas Used in This Chapter

You can also use the touch panel.

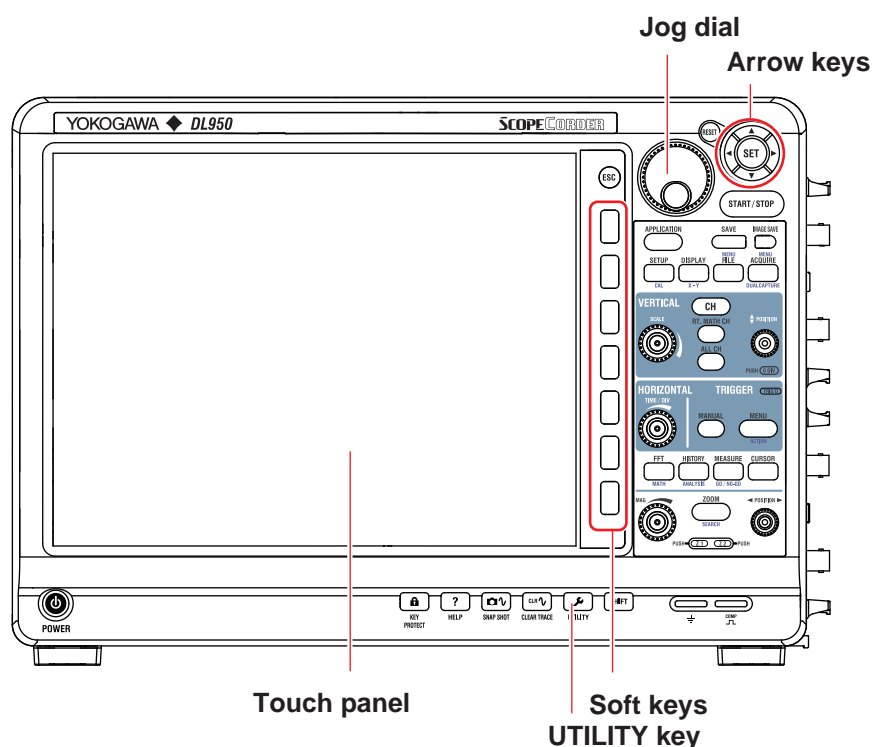

Operation Modes Applicable to the Sections in This Chapter

✓: Applicable, -: Not applicable

Section	Scope Mode	Recorder Mode
20.1 Connecting the Instrument to a Network	✓	✓
20.2 Configuring the TCP/IP Settings	✓	✓
20.3 Accessing the Instrument from a PC (FTP Server)	✓	✓
20.4 Monitoring the Instrument's Display from a PC (Web Server)	✓	✓
20.5 Connecting to a Network Drive	✓	✓
20.6 Configuring Mail Transmission (SMTP client function)	✓	✓
20.7 Using SNTP to Set the Date and Time	✓	✓
20.8 Configuring a Network Printer	✓	✓

* The settings may vary depending on the operation mode.

20.1 Connecting the Instrument to a Network

This section explains how to connect the instrument to a network.

Connecting to the Ethernet Port (1000BASE-T/100BASE-TX/10BASE-T)

Connect an Ethernet cable to the 1000BASE-T port on the side panel of this instrument.

Connector type: RJ-45 connector

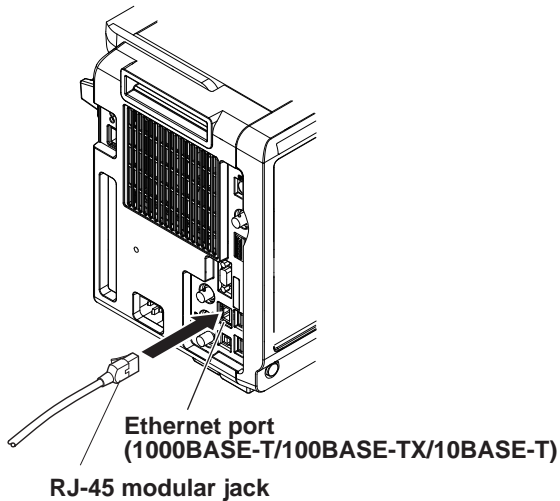

RJ-45 modular jack

Items Required to Connect the Instrument to a Network

Cable

Use one of the following types of network cable that conforms to the transfer speed of your network.

- A UTP (Unshielded Twisted-Pair) cable
- An STP (Shielded Twisted-Pair) cable

Connecting to the SFP+ Port (10GBASE-R)/(C60 option)

Mount a 10GSFP+ module to the SFP+ port on the side panel of this instrument.
For details on mounting, see the 10GSFP+ module's user's manual.

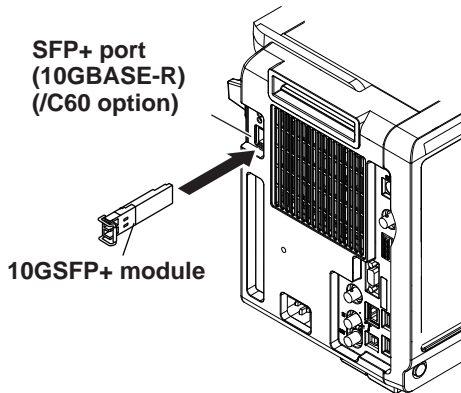

Connect an SFP+ cable to the 10GSFP+ module.

Items Required to Connect the Instrument to a Network

10GSFP+ module

Prepare an SFP+ module that is compatible with 10 Gbit Ethernet.

Connector type: SFP+

Electrical and mechanical specifications: Complies with IEEE802.3

For detailed specifications, see the *DL950 ScopeCorder Getting Started Guide* (IM DL950-03EN).

This module is not required if you are using a module-integrated cable.

SFP+ cable

Prepare a 10GBASE-R cable.

To Connect to a PC over a Network

1. Turn off the instrument.
2. Connect the connector on one end of a UTP (or STP) cable to the ETHERNET 1000BASE-T port on the side panel or the connector on one end of an STP+ cable to the 10GBASE-R port on the side panel.
3. Connect the other end of the UTP (or STP) or SFP+ cable to a hub or router.
4. Turn on the instrument.

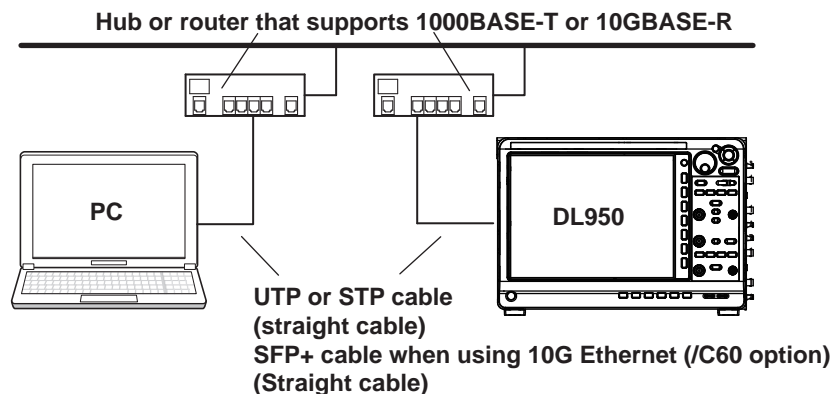

To Connect to a PC through a Hub or Router

1. Turn off the instrument and the PC.
2. Connect the connector on one end of a UTP (or STP) cable to the ETHERNET 1000BASE-T port on the side panel or the connector on one end of an STP+ cable to the 10GBASE-R port on the side panel.
3. Connect the other end of the UTP (or STP) or SFP+ cable to a hub or router.
4. Connect the PC to the hub or router in the same way.
5. Turn on the instrument.

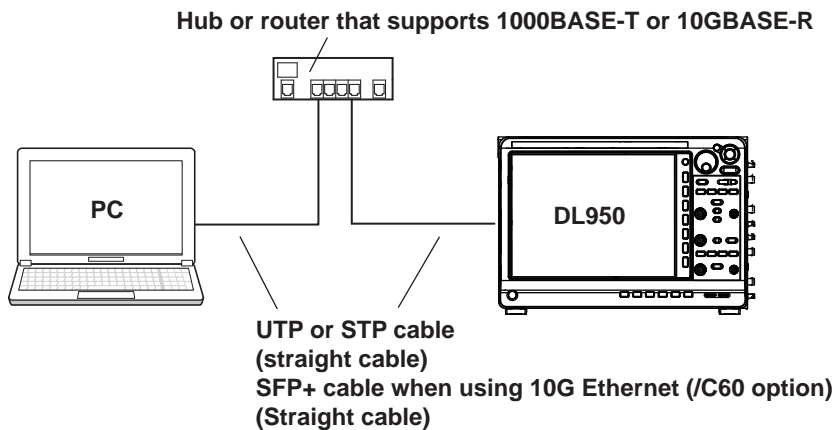

Note

- Use a hub or router that conforms to the transfer speed of your network.
 - To connect a PC to the instrument through a hub or router, the PC must be equipped with an auto 1000BASE-T/100BASE-TX/10BASE-T switching or 10GBASE-R network card.
 - Do not connect the instrument to a PC directly. Direct communication without a hub or router is not guaranteed to work.
 - If you specify a fixed IP address or network drive, be sure to use the instrument in an environment where it can be accessed. If it cannot be accessed, you may not be able to operate the instrument for the specified timeout period.
-

20.2 Configuring the TCP/IP Settings

This section explains the following TCP/IP settings for connecting to a network:

Items Common to Scope Mode and Recorder Mode

- DHCP (IP address, subnet mask, and default gateway)
- DNS (domain name, DNS server IP address, and domain suffix)
 - ▶ [“TCP/IP10G \(TCP/IP10G\), TCP/IP \(TCP/IP\)”](#) in the [Features guide](#)

UTILITY Network Menu

1. On the waveform screen’s MENU, tap **OTHERS** > **UTILITY**, or press **UTILITY**.
2. Tap **Network**, or press the soft key. The following screen appears.

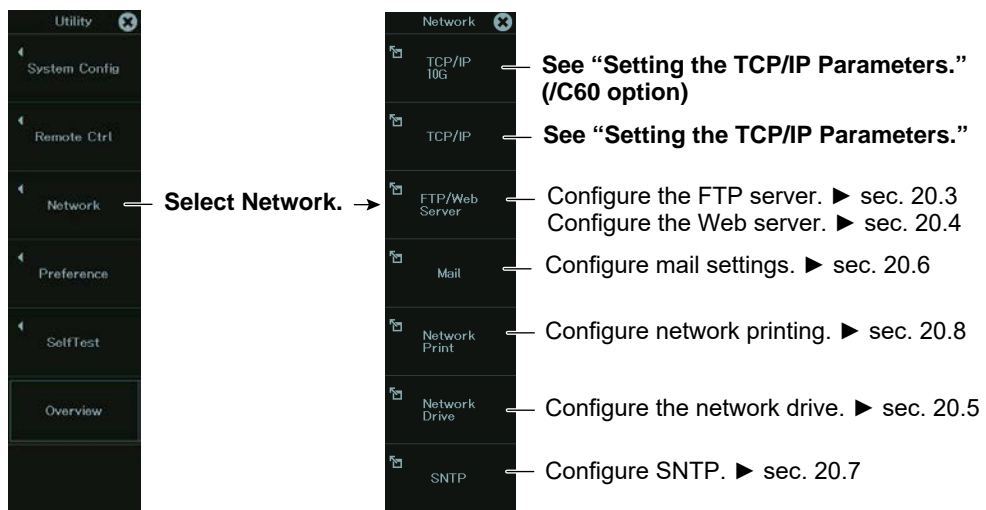

Setting the TCP/IP Parameters (TCP/IP 10G, TCP/IP)

3. Tap **TCP/IP 10G** or **TCP/IP**, or press the soft key. The following screen appears.

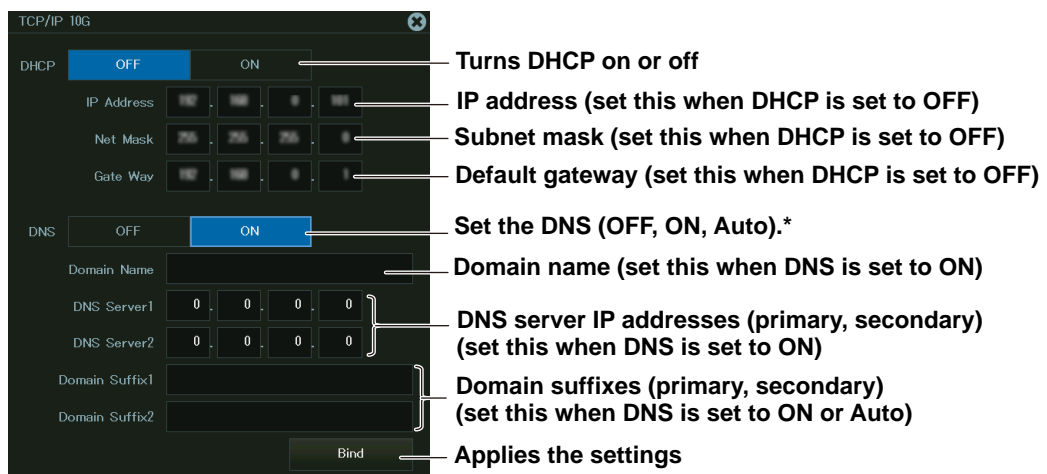

* Auto is displayed when DHCP is turned on.

Setting the DNS (DNS)

- OFF: Disable the DNS.
- ON: DNS is enabled. Set the domain name, and the DNS server's primary and secondary IP addresses and domain suffixes.
- Auto: DNS is enabled. Set the domain suffix. The domain name and the DNS server IP addresses are set automatically. This option can only be selected when DHCP is on.

20.3 Accessing the Instrument from a PC (FTP Server)

This section explains the following settings for accessing the instrument from a PC on a network:

Items Common to Scope Mode and Recorder Mode

- User name
- Password
- Timeout
- Starting an FTP client

▶ “FTP Server (FTP/Web Server)” in the Features Guide

UTILITY Network Menu

1. On the waveform screen’s MENU, tap **OTHERS > UTILITY**, or press **UTILITY**.
2. Tap **Network**, or press the soft key. The following screen appears.

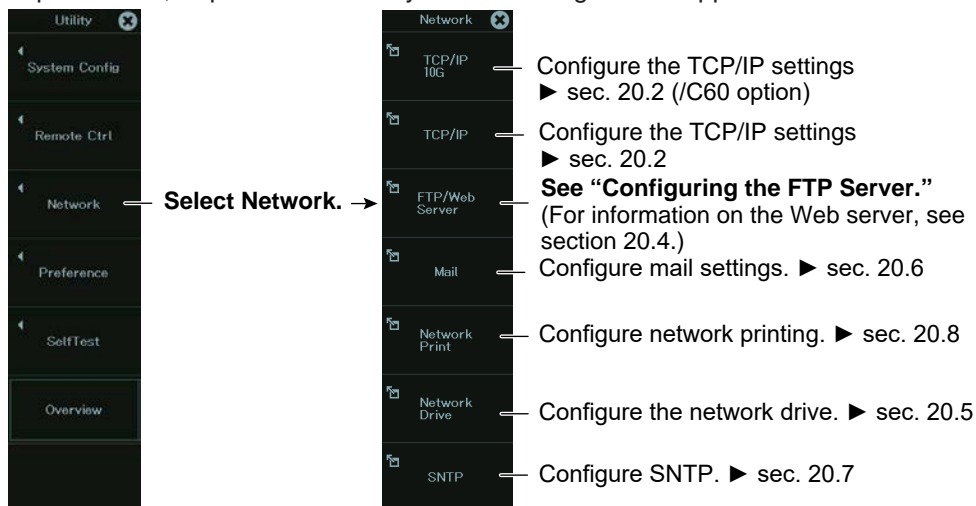

Configuring the FTP Server (FTP/Web Server)

3. Tap **FTP/Web Server**, or press the soft key. The following screen appears.

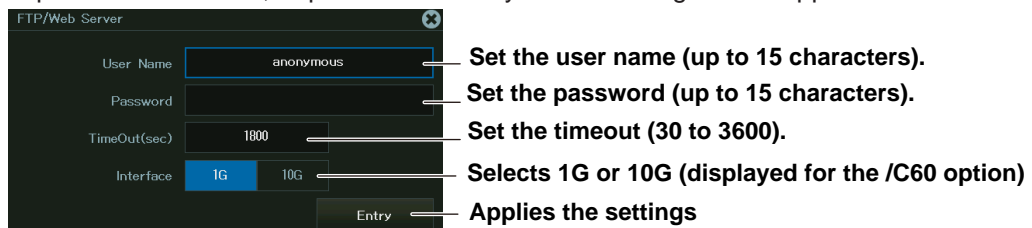

Note

If you set the user name to “anonymous,” you can connect to the instrument without entering a password.

Starting an FTP Client

Start an FTP client on a PC. Enter the user name and password that you have set on the instrument’s FTP/Web Server screen shown above, and connect to the instrument.

20.4 Monitoring the Instrument's Display from a PC (Web Server)

This section explains the following settings for connecting to the instrument from a PC over a network to show the instrument's display on the PC and to start and stop waveform acquisition from the PC:

Items Common to Scope Mode and Recorder Mode

- User name
- Password
- Timeout
- Connecting to the instrument from a PC

► [“Web Server \(FTP/Web Server\)” in the Features Guide](#)

UTILITY Network Menu

1. On the waveform screen's MENU, tap **OTHERS** > **UTILITY**, or press **UTILITY**.
2. Tap **Network**, or press the soft key. The following screen appears.

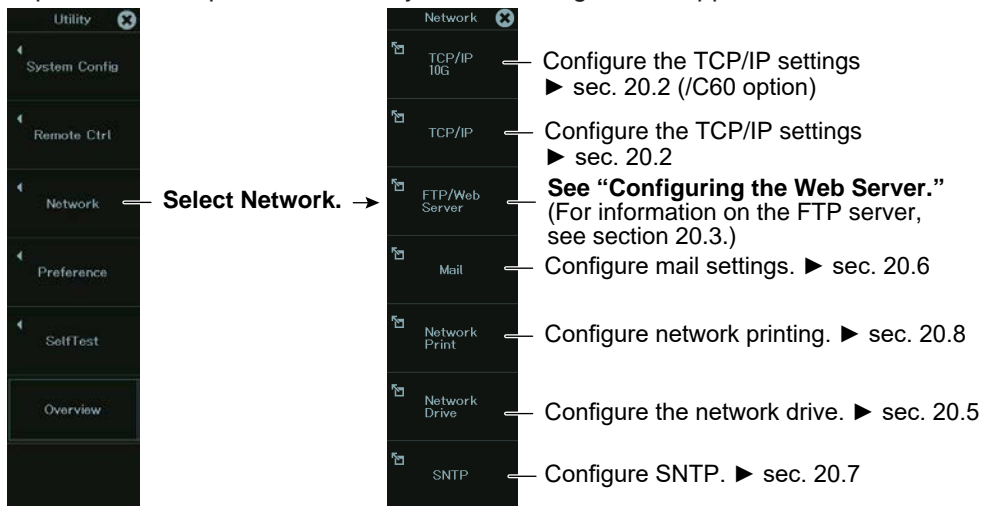

Configuring the Web Server (FTP/Web Server)

3. Tap **FTP/Web Server**, or press the soft key. The following screen appears.

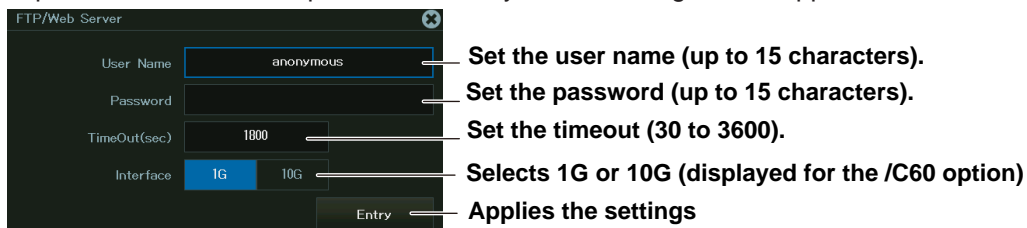

20.5 Connecting to a Network Drive

This section explains the following settings for accessing a network drive through an Ethernet connection to load or save various instrument's data:

Items Common to Scope Mode and Recorder Mode

- FTP server (file server)
- Login name
- Password
- Turning FTP passive mode on and off
- Timeout
- Connecting to and disconnecting from network drives

▶ **“Network Drive (Net Drive)” in the Features Guide**

UTILITY Network Menu

1. On the waveform screen's MENU, tap **OTHERS > UTILITY**, or press **UTILITY**.
2. Tap **Network**, or press the soft key. The following screen appears.

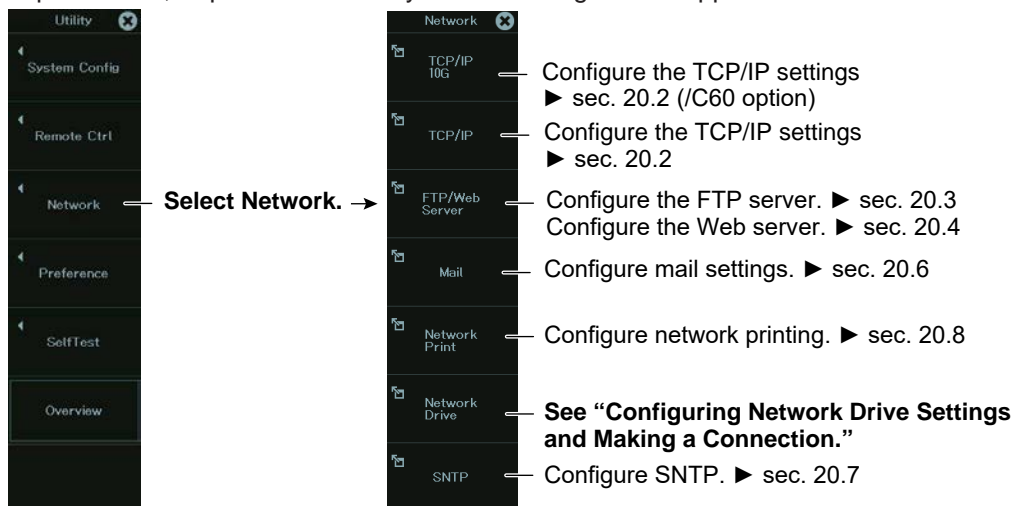

Configuring Network Drive (Network Drive) Settings and Making a Connection

3. Tap **Network Drive**, or press the soft key. The following screen appears.

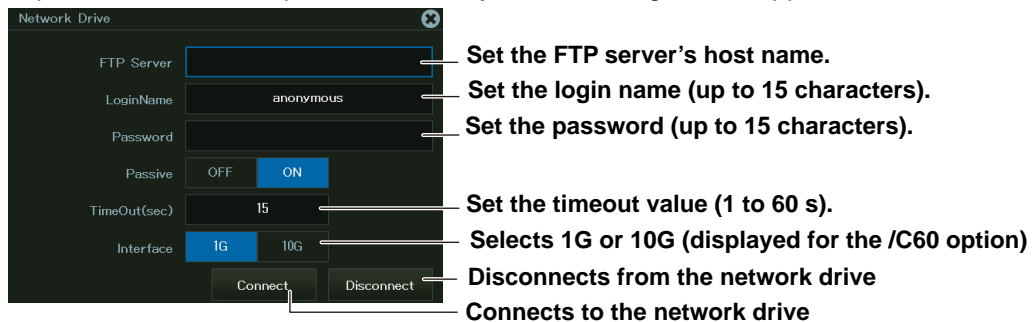

20.6 Configuring Mail Transmission (SMTP client function)

This section explains the following settings for transmitting mail to a specified mail address on a network:

Items Common to Scope Mode and Recorder Mode

- Mail server
- Recipient mail address
- Comment
- Attaching image files
- Timeout
- Sending a test mail

▶ “Mail (Mail)” in the Features Guide

UTILITY Network Menu

1. On the waveform screen's MENU, tap **OTHERS** > **UTILITY**, or press **UTILITY**.
2. Tap **Network**, or press the soft key. The following screen appears.

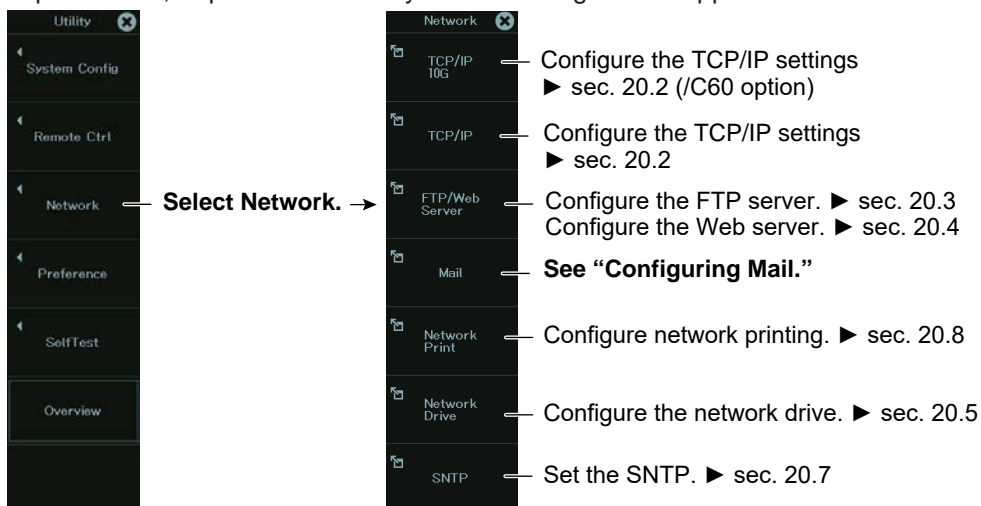

Configuring Mail (Mail)

3. Tap **Mail**, or press the soft key. The following screen appears.

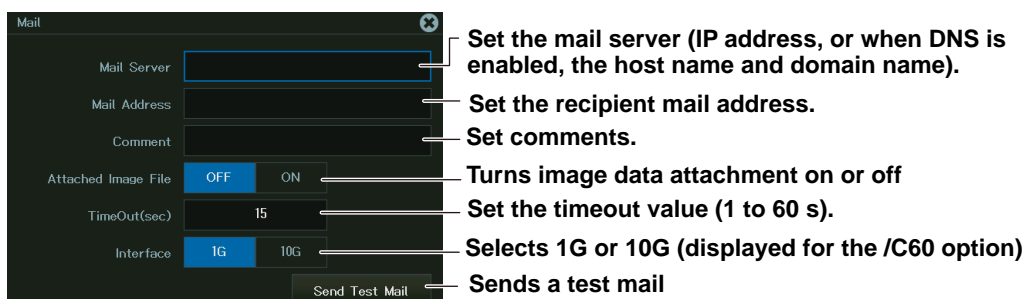

20.7 Using SNTP to Set the Date and Time

This section explains how to use SNTP to set the Instrument's date and time.

Items Common to Scope Mode and Recorder Mode

- SNTP server
- Timeout
- Executes clock adjustment
- Automatic adjustment

► “SNTP (SNTP)” in the Features Guide

UTILITY Network Menu

1. On the waveform screen's MENU, tap **OTHERS** > **UTILITY**, or press **UTILITY**.
2. Tap **Network**, or press the soft key. The following screen appears.

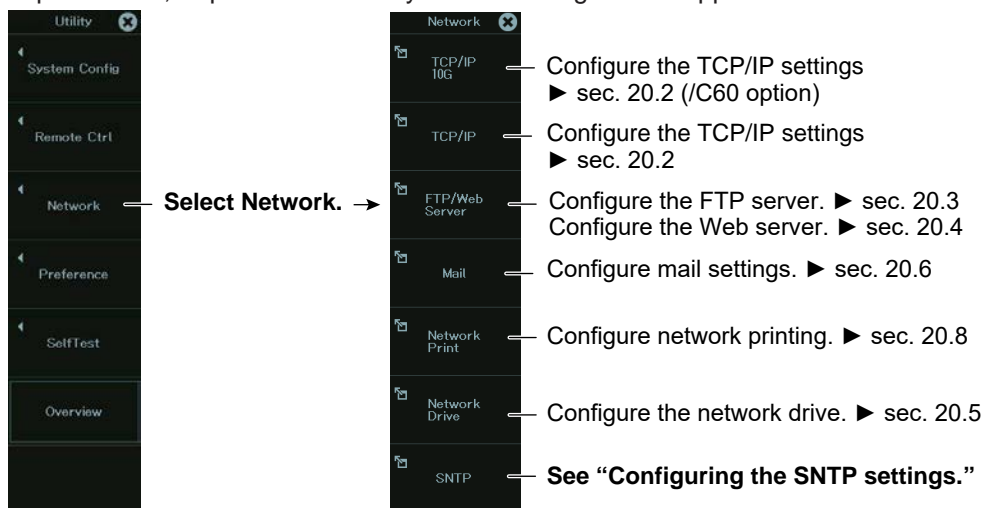

Configuring the SNTP Settings (SNTP)

3. Tap **SNTP**, or press the soft key. The following screen appears.

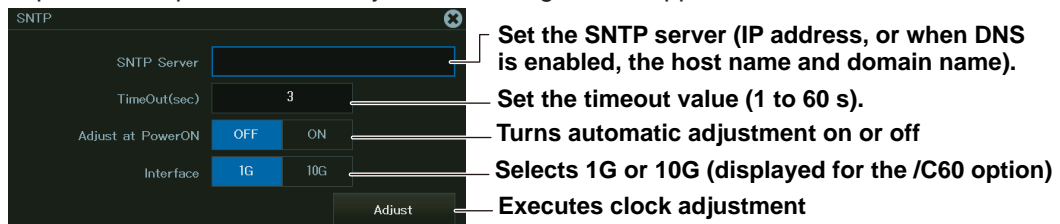

20.8 Configuring a Network Printer

This section explains the following settings for printing screen images to a network printer:

Items Common to Scope Mode and Recorder Mode

- LPR server
- LPR name
- Timeout

► “Network Printer (Net Print)” in the Features Guide

UTILITY Network Menu

1. On the waveform screen’s MENU, tap **OTHERS** > **UTILITY**, or press **UTILITY**.
2. Tap **Network**, or press the soft key. The following screen appears.

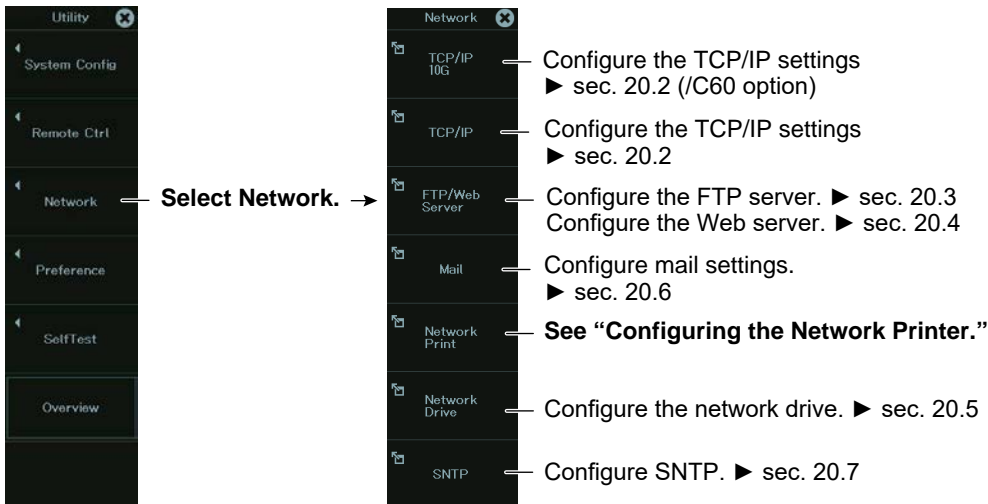

Configuring the Network Printer (Network Print)

3. Tap **Network Print**, or press the soft key. The following screen appears.

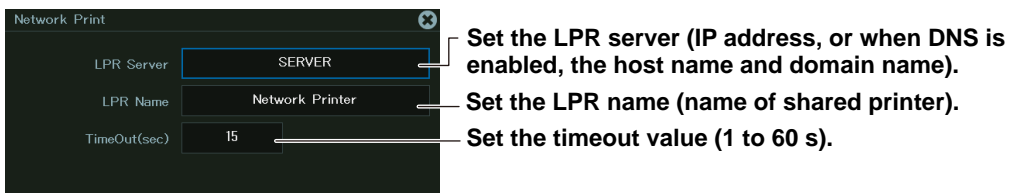

Chapter 21

Time Synchronization

Main Control Areas Used in This Chapter

You can also use the touch panel.

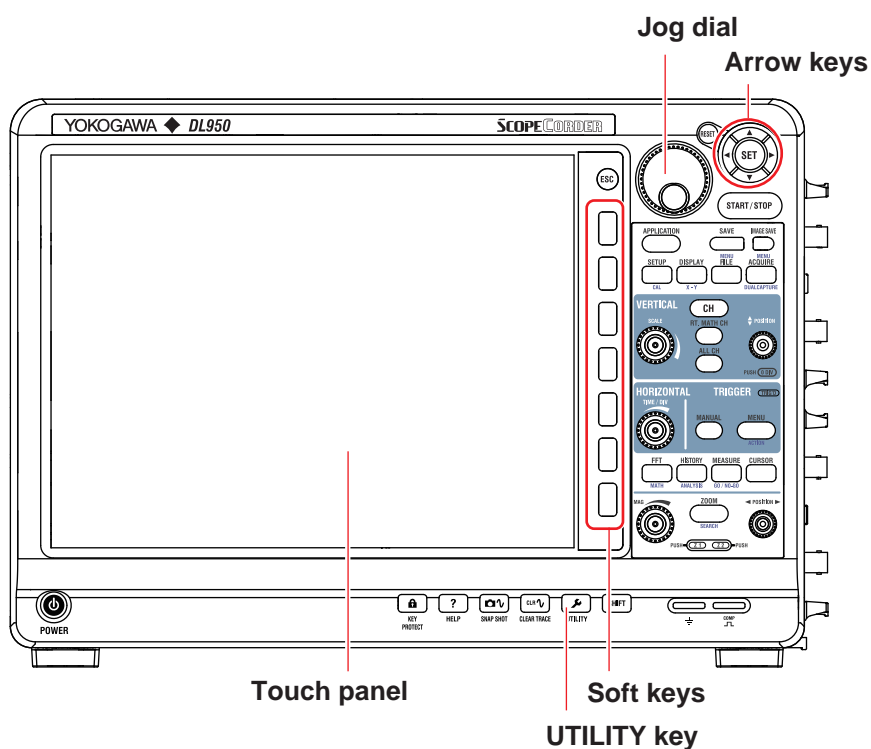

Operation Modes Applicable to the Sections in This Chapter

✓: Applicable, -: Not applicable

Section	Scope Mode	Recorder Mode
21.1 Setting Time Synchronization Mode	✓	✓
21.2 Configuring Master Settings (/C40 option)	✓	✓

* The settings may vary depending on the operation mode.

21.1 Setting Time Synchronization Mode

This section explains the following setting for synchronizing instruments on a network.

Items Common to Scope Mode and Recorder Mode

- Time synchronization mode
- Configuring IRIG settings
- Configuring IEEE1588 settings

► [“Time Synchronization” in the Features Guide](#)

Utility System Config Time Sync Menu

1. On the waveform screen’s MENU, tap **OTHERS** > **UTILITY**, or press **UTILITY**.
2. Tap **System Config**, or press the soft key.
3. Tap **Time Sync**, or press the soft key. The following screen appears.

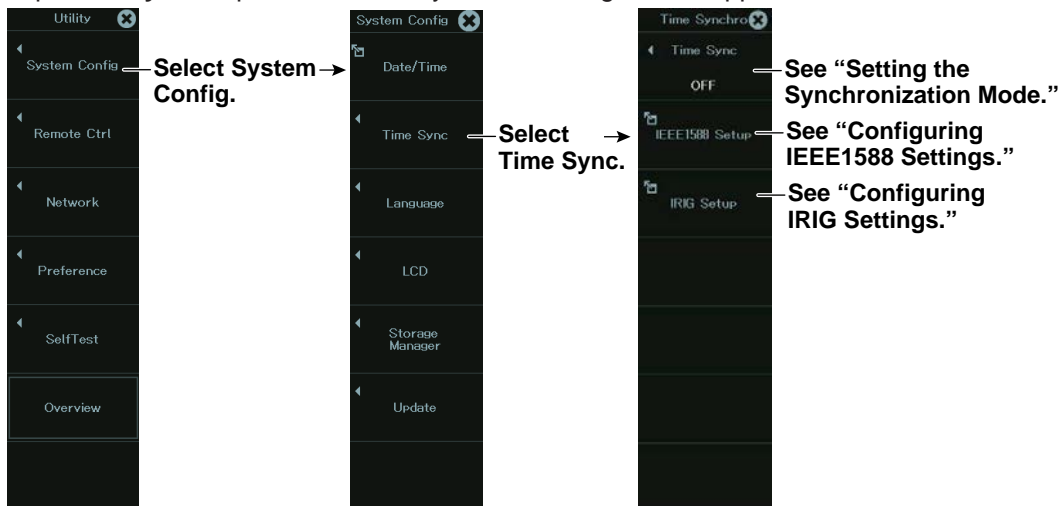

Setting the Synchronization Mode (Time Sync)

4. Tap **Time Sync**, or press the soft key. The following screen appears.

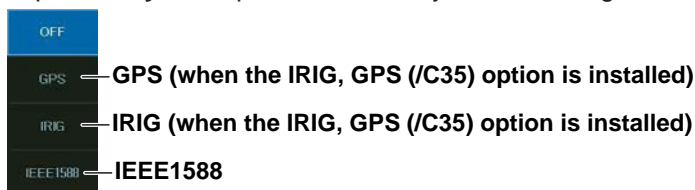

Configuring IEEE1588 Settings (IEEE1588)

4. Tap **IEEE1588**, or press the soft key. The following screen appears.

When the IEEE1588 master function (/C40) option is not installed

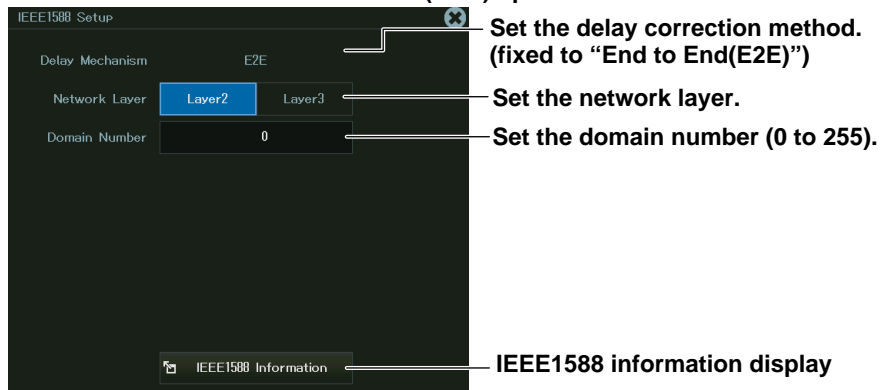

When the IEEE1588 master function (/C40) option is installed

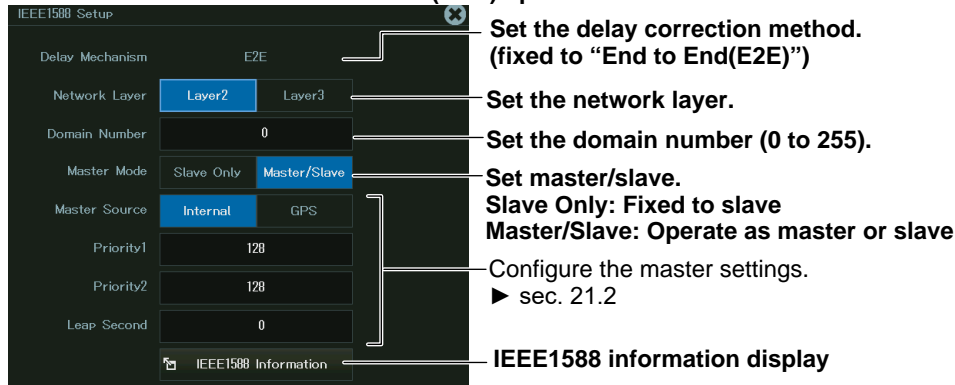

IEEE1588 Information Display



Configuring IRIG Settings (IRIG)

4. Tap **IRIG**, or press the soft key. The following screen appears.

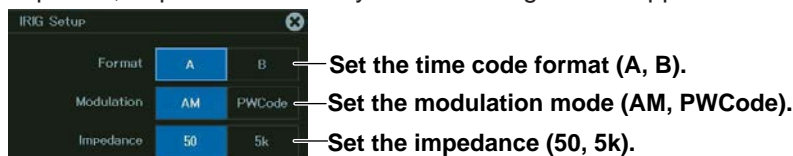

21.2 Configuring Master Settings (/C40 option)

This section explains the following settings that are necessary for this instrument to be selected as a master unit in IEEE1588.

Items Common to Scope Mode and Recorder Mode

- Master mode
- Clock source
- Priority1, Priority2
- Leap second

► “IEEE1588 Setup (IEEE1588 Setup)” in the Features Guide

Utility System Config Time Sync Menu

1. On the waveform screen’s MENU, tap **OTHERS** > **UTILITY**, or press **UTILITY**.
2. Tap **System Config**, or press the soft key.
3. Tap **Time Sync**, or press the soft key. The following screen appears.

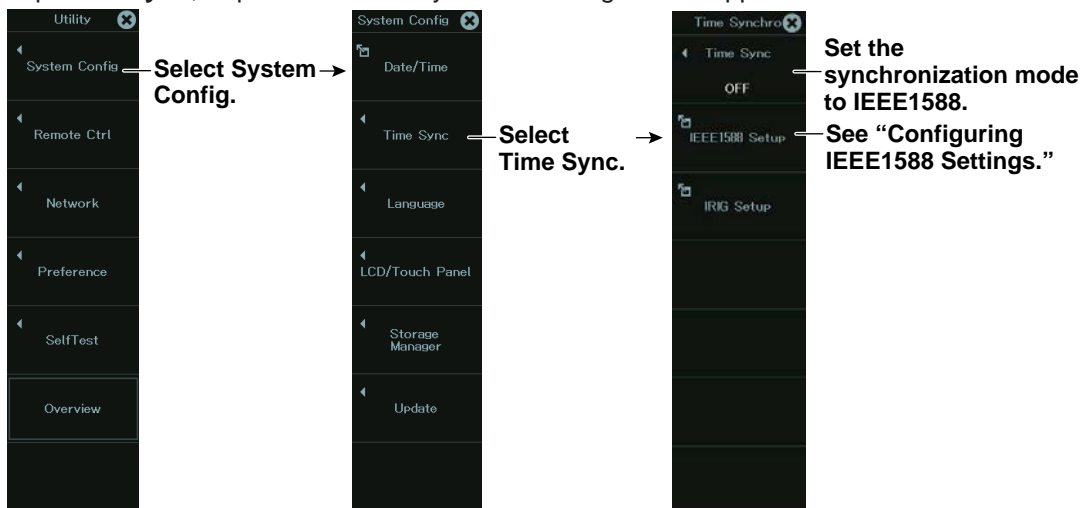

Configuring IEEE1588 Settings (IEEE1588)

4. Tap **IEEE1588**, or press the soft key. The following screen appears.

The screenshot shows the IEEE1588 Setup screen with the following settings and annotations:

Setting	Value	Annotation
Delay Mechanism	E2E	Set the time synchronization. ▶ sec. 21.1
Network Layer	Layer2	Select Master/Slave.
Domain Number	0	
Master Mode	Master/Slave	Set the master clock source.
Master Source	Internal	Set Priority1 (0 to 255).
Priority1	128	Set Priority2 (0 to 255).
Priority2	128	Set the leap second (0 to 999).
Leap Second	0	IEEE1588 information display

Master Source GPS is available on models with the IRIG/GPS option (/C35).

In IEEE1588, the master clock in the network is selected according to the rules stipulated in the IEEE1588 standard, taking into account the Priority1 and Priority2 values.

Devices with smaller Priority1 and Priority2 values have priority in selecting the master clock.

Chapter 22

Connecting Multiple Instruments (/C50 option)

Main Control Areas Used in This Chapter

You can also use the touch panel.

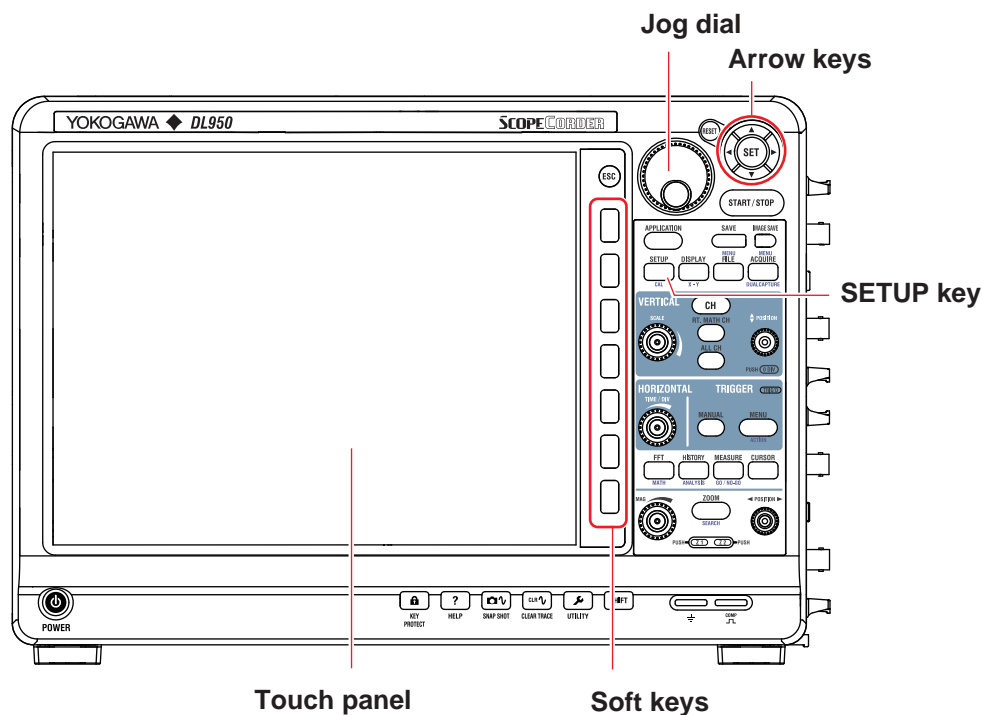

Operation Modes Applicable to the Sections in This Chapter

✓: Applicable, -: Not applicable

Section	Scope Mode	Recorder Mode
22.1 Connecting Multiple Instruments	✓	✓
22.2 Configuring the Multiple-Unit Connection	✓	✓
22.3 Starting and Stopping Waveform Acquisition	✓	✓

* The settings may vary depending on the operation mode.

22.1 Connecting Multiple Instruments

This section explains how to connect multiple DL950s.

Items Common to Scope Mode and Recorder Mode

- Installing SFP modules
- Connecting optical cables

▶ [“Synchronizing Multiple Instruments \(/C50 option\)” in the Features Guide](#)

CAUTION

- Be extremely careful of static electricity when you install or remove SFP modules. Electrostatic discharges during the installation or removal of these modules may cause them to malfunction.
 - Do not install or remove SFP modules while cables are connected to them. Doing so may damage the instrument.
-

French

ATTENTION

- Se méfier extrêmement de l'électricité statique lors d'installer ou retirer des modules d'émetteur-récepteur optiques. La décharge électrostatique lors de l'installation ou du retrait de ces modules pourrait causer leur dysfonctionnement.
 - Ne pas installer ou ne pas retirer les modules d'émetteur-récepteur optique lorsque des cordons de fibre optique y sont connectés. Cela pourrait endommager l'instrument.
-

Installing SFP Modules

To connect multiple DL950s, you need 720941 SFP modules, which are optional accessories, and optical fiber cords. For optical fiber cords, use the 720942 optional accessories or use your own multi-mode optical fiber cords (LC type).

1. Turn off the instrument.
2. Insert 720941 SFP modules into the link connectors on the right side of the instrument's front panel. Tilt the latch lever on the SFP module, align the SFP module with the guide on the link connector, and slowly insert it. Push it until you hear a click.

When installing an SFP module into a sub unit, connect it to the top connector.

Install it with the latch lever tilted down. If it is installed with the latch lever raised, it cannot be installed normally.

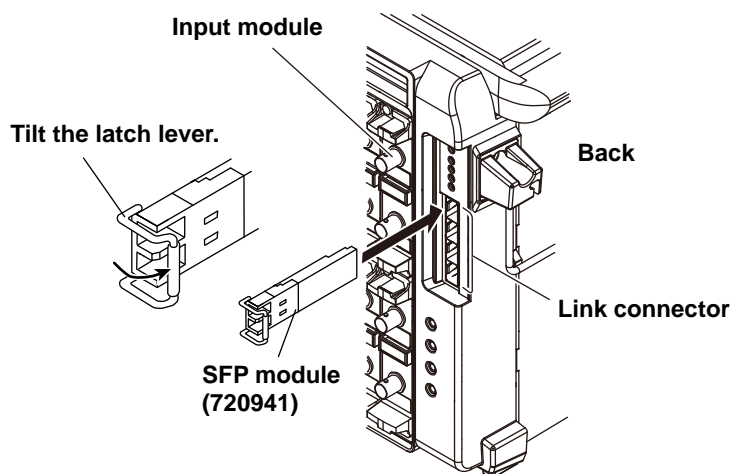

Note

- Be sure to use the 720941 optional accessory for the SFP module. If you use a different SFP module, the instrument's functions and performance are not guaranteed. In addition, a malfunction caused by using a different SFP module is not covered by warranty.
- There are connectors with the same shape as those of link connectors on the left side of the instrument's front panel, but they are 10G Ethernet connectors. You cannot use them to connect SFP modules.

Removing SFP Modules

1. Turn off the instrument.
2. Remove the optical fiber cord from the instrument.
3. Raise the latch lever on the SFP module toward you and slowly pull the module out. The connector will be disengaged, and the SFP module will come out of the link connector.

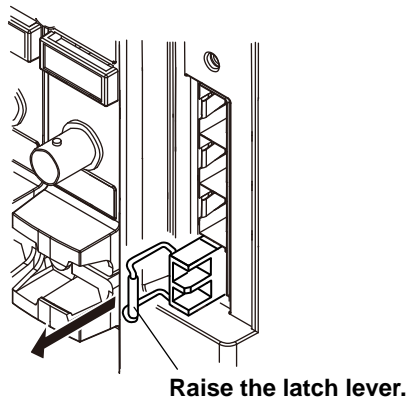

Connecting Optical Fiber Cords

CAUTION

- Insert the optical fiber cord connectors slowly and straight into the optical ports. If you shake the connector to the left and right or force it into the port, the optical connector or optical port may be damaged.
- If you use optical connectors that do not meet the specifications, the instrument's optical ports may be damaged. Use optical connectors that are approved or used by national or local telecom carriers and providers in your area.

French

ATTENTION

- Insérer lentement et droit le connecteur du cordon de fibre optique dans l'orifice optique en tenant le connecteur. Si vous secouez le connecteur vers la gauche et la droite ou si vous le forcez dans l'orifice, le connecteur ou l'orifice optique pourrait être endommagé.
- Toujours utiliser des connecteurs optiques conformes aux spécifications, à défaut de quoi les ports optiques de l'DL950 pourraient être endommagés. Utiliser des connecteurs optiques homologués ou utilisés par les entreprises et les fournisseurs de services de télécommunications de votre région.

Connect multiple DL950s using the 720942 optical fiber cord, sold separately.

If you are preparing your own optical fiber cords, use multi-mode optical fiber cords (LC type).

1. Properly align the optical fiber cord's connector with the SFP module's optical port, and insert the connector.

Note

Clean the connector end face of the optical fiber cord before connecting it to the instrument. If dust is adhered to the connector end face, it may damage the instrument's optical port. If this happens, the instrument will not be able to communicate.

When cleaning the end face of the connector, use a cleaner dedicated to fiber optic cords.

Connect the main unit and sub units in a star configuration as shown in the following figure.

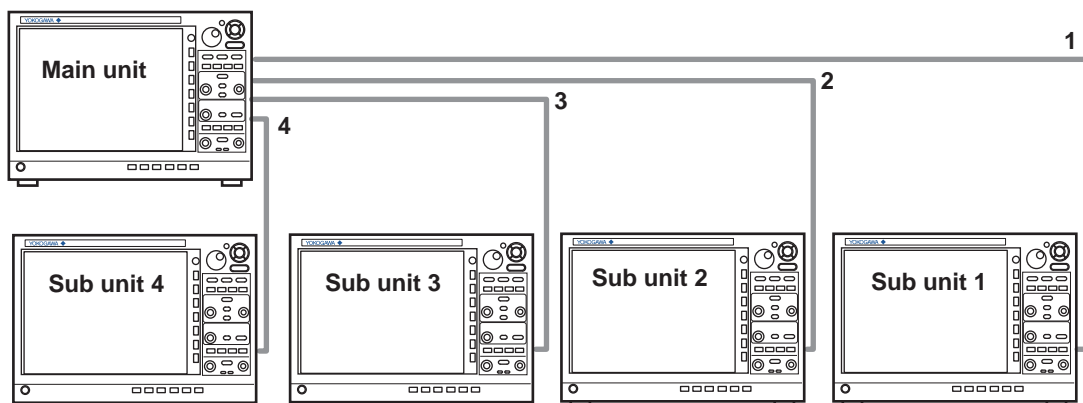

The sub unit numbers 1 to 4 are assigned in order from the top connector of the main unit to be connected.

22.2 Configuring the Multiple-Unit Connection

This section explains the following settings for connecting multiple DL950s.

Items Common to Scope Mode and Recorder Mode

- Configuring the main unit and sub units
- Connection and disconnection

▶ “Synchronizing Multiple Instruments (/C50 option)” in the Features Guide

SETUP Multi Unit Sync. Menu

1. On the waveform screen's MENU, tap **SETUP** > **SETUP**, or press **SETUP**.
2. Tap **Multi Unit Sync.**, or press the soft key. The following screen appears.

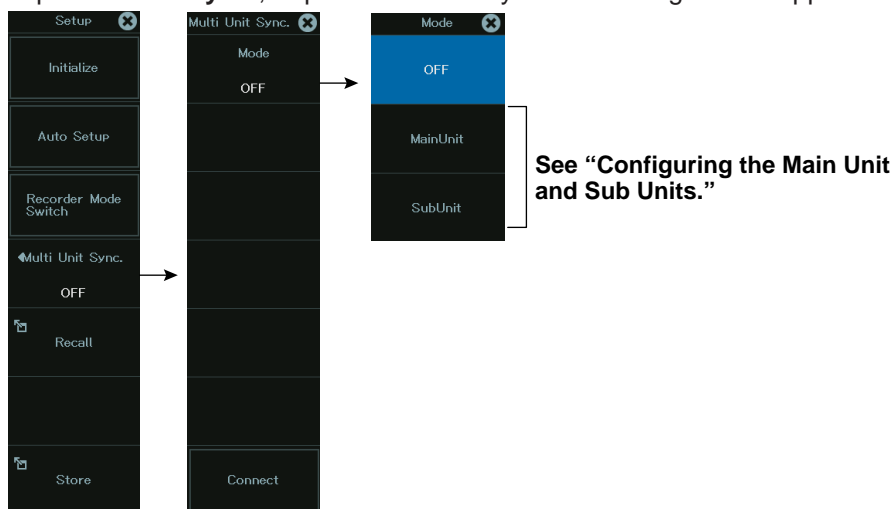

Configuring the Main Unit and Sub Units

3. Tap **MainUnit** or **SubUnit**, or press the soft key. The following screen appears.

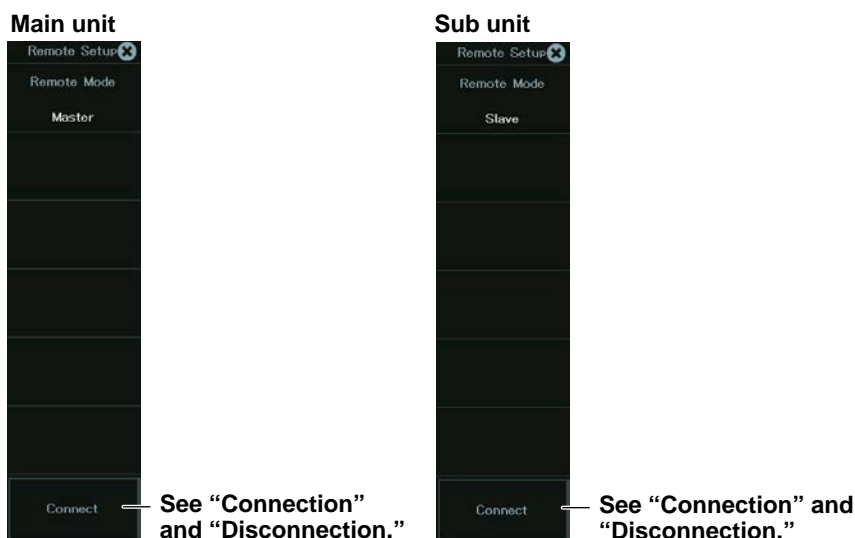

Connection

4. On the main unit menu and all sub unit menus, tap **Connect**, or press the soft key. The main unit and sub units will be connected. When the connection operation on some units is not complete, the Connect menu on units that connection operation has been completed changes to Cancel. When the connection operation on all units is complete, Cancel changes to Disconnect.

Note

The connection operation must be performed on the main unit and all the sub units connected to the main unit. The link feature will not work if the connection operation is not performed on any of the units.

Disconnection

5. While connected, tap **Disconnect**, or press the soft key on the main unit menu or a sub unit menu. The connection will be disconnected.

When the link is disconnected on a sub unit, the link feature between the main unit and all connected sub units will be disabled.
6. To reconnect, on the main unit menu and the sub unit menus, tap **Connect**, or press the soft key.

22.3 Starting and Stopping Waveform Acquisition

Items Common to Scope Mode and Recorder Mode

- Starting and stopping waveform acquisition
 - ▶ [“Synchronizing Multiple Instruments \(/C50 option\)” in the Features Guide](#)

Waveform Acquisition (START and STOP)

Perform the operation on the main unit.

1. On the main unit waveform screen's **MENU**, tap **START/STOP**, or press **START/STOP**.
Waveform acquisition starts or stops on the main unit and sub units.

Waveform acquisition is in progress when the START/STOP key is illuminated.

Setting Items That Give Priority to the Settings of the Main Unit

When multiple DL950s are connected, the following settings on the main unit take priority. The settings on the sub units are overwritten with the settings on the main unit.

- Record length
- Time base, T/Div
- Acquisition mode
- Trigger mode
- Number of measurements
- SSD recording settings
- Dual capture settings
- Trigger position, trigger delay
- Hold-off time
- Action trigger settings
- Accumulation display
- Current history number
- Search feature
- Go-Nogo settings
- Save operation

The following features will not work when the units are linked.

- Averaging function
- Single-N trigger, line trigger, wave window trigger, sub units' external trigger
- Enhanced trigger other than OR
- History search
- History averaging
- All history record display
- Waveform acquisition start using power-on action
- Remotely stopping waveform acquisition

Saving Data

Waveform Data

When you execute a save operation on the main unit, the sub units will also save their waveform data in their storage areas.

“Main” is added to the normal file name on the main unit. “Sub(N)” is added on the sub units.

Setup Data

The setup data is saved in the main unit.

If the DL950s are connected with the same configuration as when the setup data was saved, you can perform measurements with the same conditions by loading the setup data.

If the link configuration is different from that in the setup data, the setup data cannot be loaded.

Load setup data on each unit.

Screen Capture Data

Screen captures of the main unit can be saved.

Screen captures of the sub units cannot be saved.

Chapter 23

Other Operations

Main Control Areas Used in This Chapter

You can also use the touch panel.

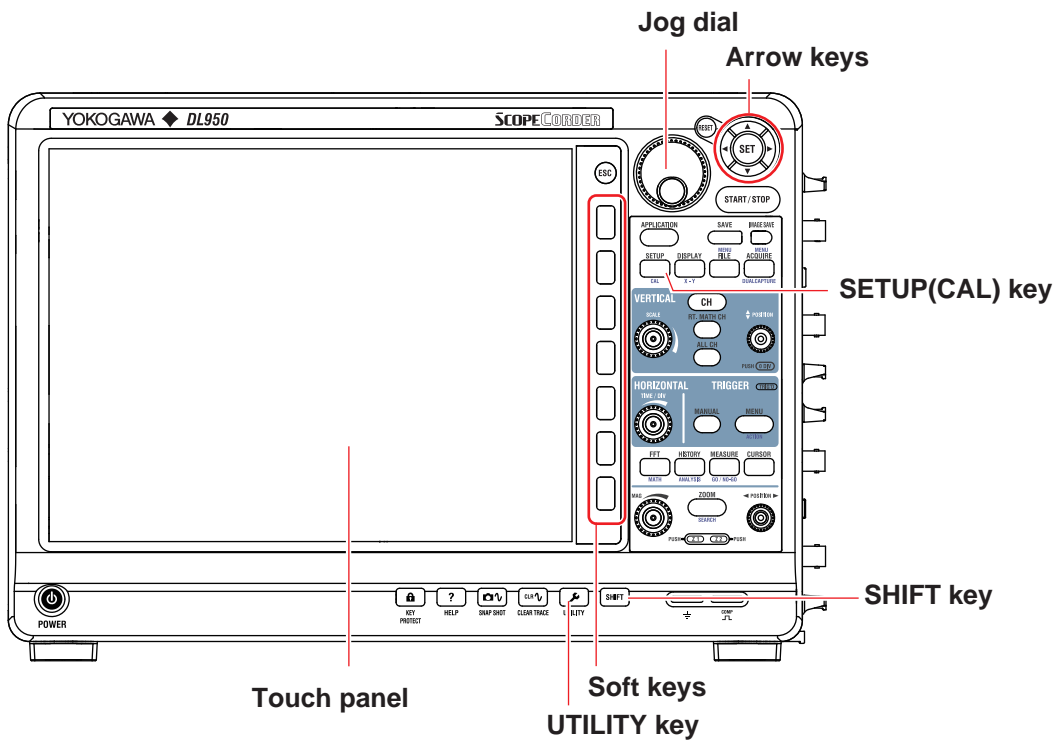

Operation Modes Applicable to the Sections in This Chapter

✓: Applicable, -: Not applicable

Section	Scope Mode	Recorder Mode
23.1 Storing and Recalling Setup Data	✓	✓
23.2 Calibrating the Instrument	✓	✓
23.3 Changing the Message, Menu, and USB Keyboard Languages	✓	✓
23.4 Configuring the LCD	✓	✓
23.5 Using the Instrument as a USB Storage Device	✓	✓
23.6 Configuring the Environment Settings	✓	✓
23.7 Locking the Keys	✓	✓

* The settings may vary depending on the operation mode.

23.1 Storing and Recalling Setup Data

This section explains how to save the instrument settings to the internal memory and how to load settings from the internal memory.

Items Common to Scope Mode and Recorder Mode

- Storing and recalling setup data
 - ▶ “Setup Data Store/Recall (Store/Recall)” in the Features Guide

SETUP Store/Recall Menu

1. On the waveform screen’s MENU, tap **SETUP** > **SETUP**, or press **SETUP**. The following screen appears.

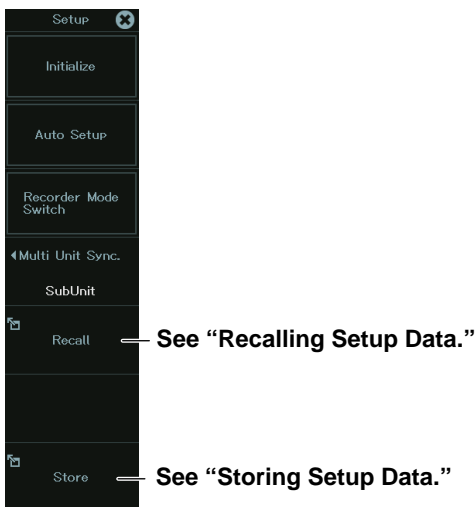

Storing Setup Data

2. Tap **Store**, or press the soft key. The following screen appears.

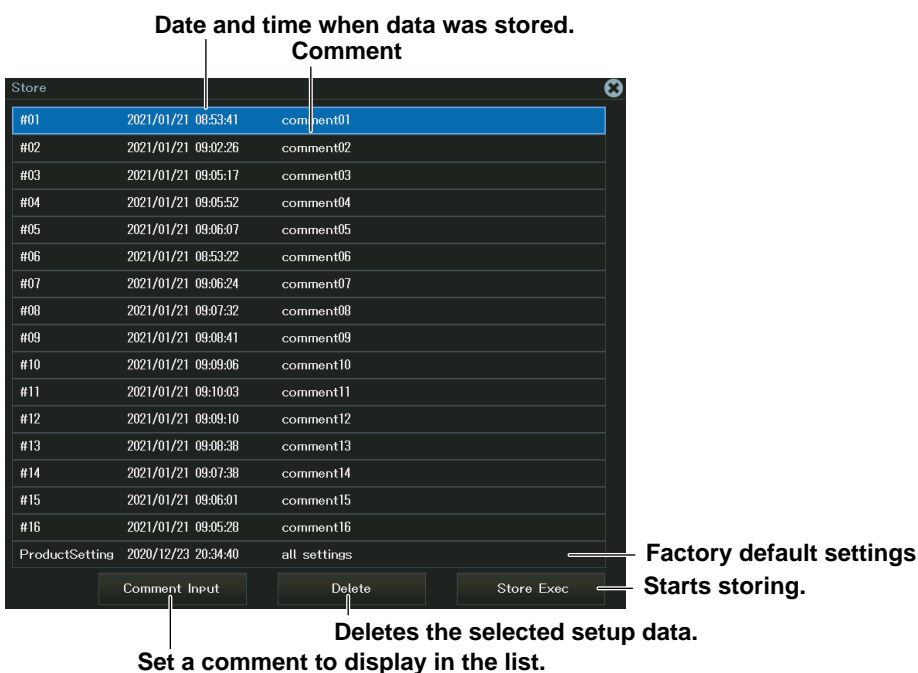

3. Tap **Store Exec**, or select **Store Exec** using the jog dial or arrow keys, and press **SET**. The setup data is saved at the selected number. If setup data is registered at the selected number, it will be overwritten.

Recalling Setup Data

2. Tap **Recall**, or press the soft key. The following screen appears.

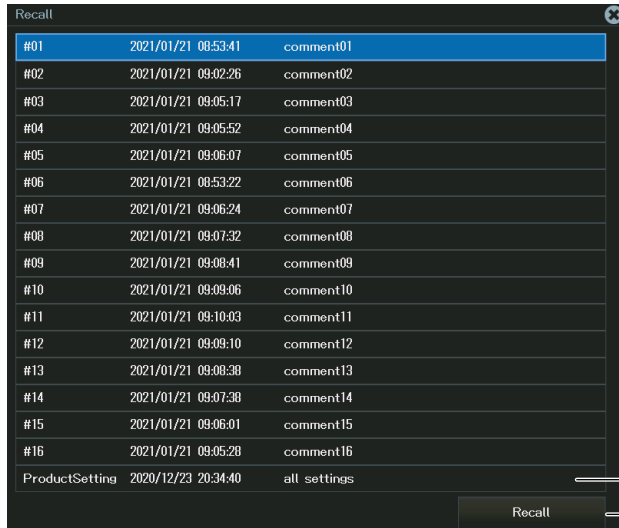

ID	Date/Time	Comment
#01	2021/01/21 08:53:41	comment01
#02	2021/01/21 09:02:26	comment02
#03	2021/01/21 09:05:17	comment03
#04	2021/01/21 09:05:52	comment04
#05	2021/01/21 09:06:07	comment05
#06	2021/01/21 08:53:22	comment06
#07	2021/01/21 09:06:24	comment07
#08	2021/01/21 09:07:32	comment08
#09	2021/01/21 09:08:41	comment09
#10	2021/01/21 09:09:06	comment10
#11	2021/01/21 09:10:03	comment11
#12	2021/01/21 09:09:10	comment12
#13	2021/01/21 09:08:38	comment13
#14	2021/01/21 09:07:38	comment14
#15	2021/01/21 09:06:01	comment15
#16	2021/01/21 09:05:28	comment16
ProductSetting	2020/12/23 20:34:40	all settings

Factory default settings

Recalls the setup data

23.2 Calibrating the Instrument

This section explains how to calibrate the instrument. Execute calibration when you want to make accurate measurements.

Items Common to Scope Mode and Recorder Mode

- Executes calibration
 - ▶ “Calibration (CAL)” and “Power Integration Calibration (/G05 option)” in the Features Guide

CAL Menu

1. On the waveform screen’s MENU, tap **SETUP > CAL**, or press **SHIFT+SETUP (CAL)**. The following screen appears.

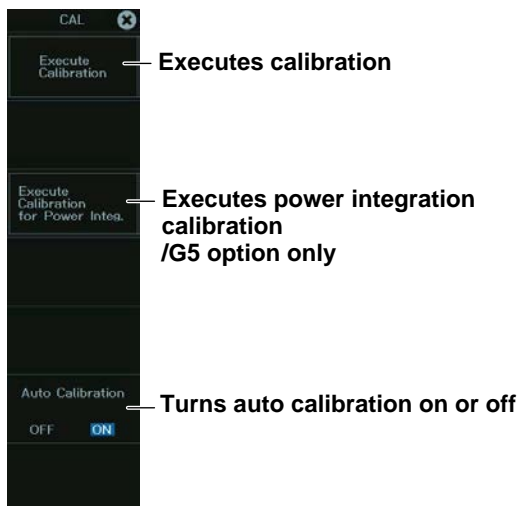

Resetting All Settings to Their Factory Default Values

See section 4.6 in the *DL950 Getting Started Guide* (IM DL950E-03EN).

23.3 Changing the Message, Menu, and USB Keyboard Languages

This section explains the following settings:

Items Common to Scope Mode and Recorder Mode

- Message language
- Menu language
- USB keyboard language

► “System Configuration (System Config)” in the Features Guide

UTILITY System Config Menu

1. On the waveform screen’s MENU, tap **OTHERS** > **UTILITY**, or press **UTILITY**.
2. Tap **System Config**, or press the soft key. The following screen appears.

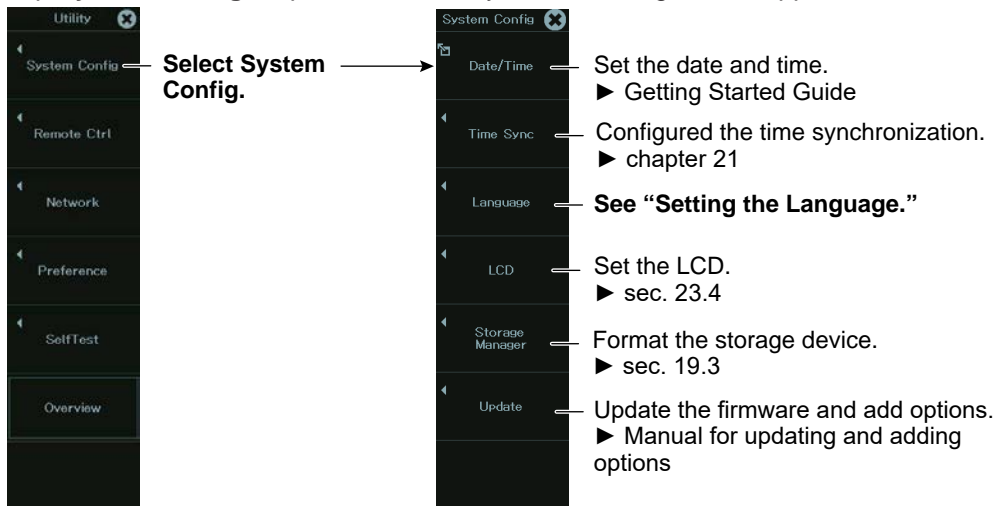

Setting the Language (Language)

3. Tap **Language**, or press the soft key. The following screen appears.

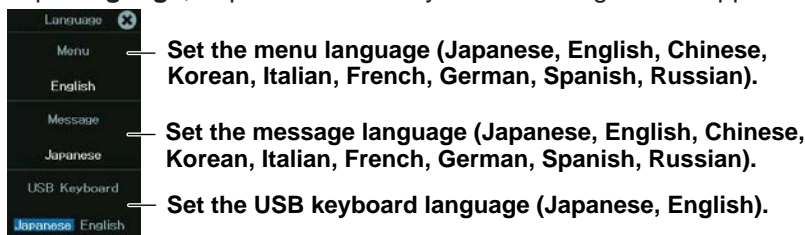

Note

Some terminology is always displayed in English.

Setting the USB Keyboard Language (USB Keyboard)

You can use the following keyboards that conform to USB Human Interface Devices (HID) Class Ver. 1.1.

English: 104-key keyboards

Japanese: 109-key keyboards

For details on how the keys of this instrument are mapped to the keys on a USB keyboard, see appendix 10 in the *Getting Started Guide* (IM DL950E-03EN).

23.4 Configuring the LCD

This section explains the following settings for adjusting the LCD:

Items Common to Scope Mode and Recorder Mode

- Turning the display on and off
- Setting auto-off
- Setting the LCD brightness

► “System Configuration (System Config)” in the Features Guide

UTILITY System Config Menu

1. On the waveform screen’s MENU, tap **OTHERS** > **UTILITY**, or press **UTILITY**.
2. Tap **System Config**, or press the soft key. The following screen appears.

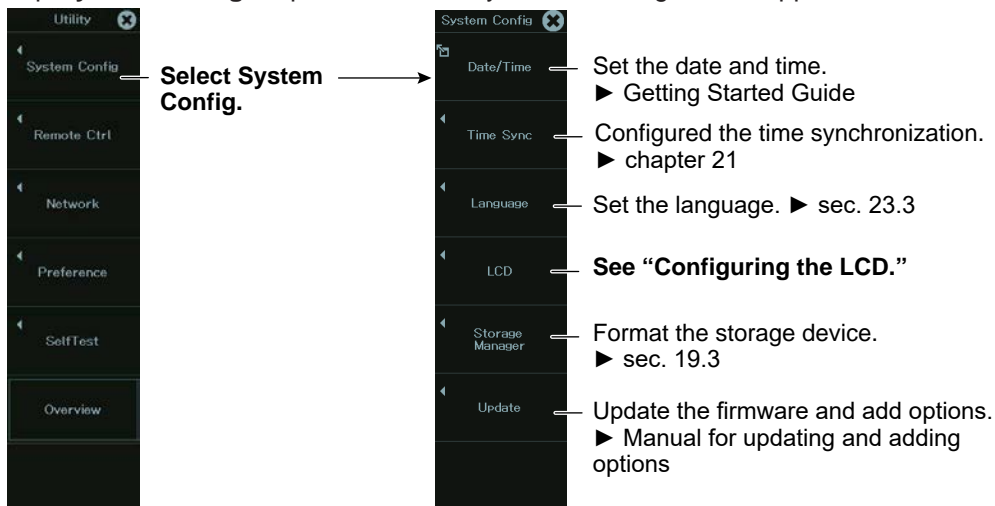

Configuring the LCD (LCD)

3. Tap **LCD**, or press the soft key. The following screen appears.

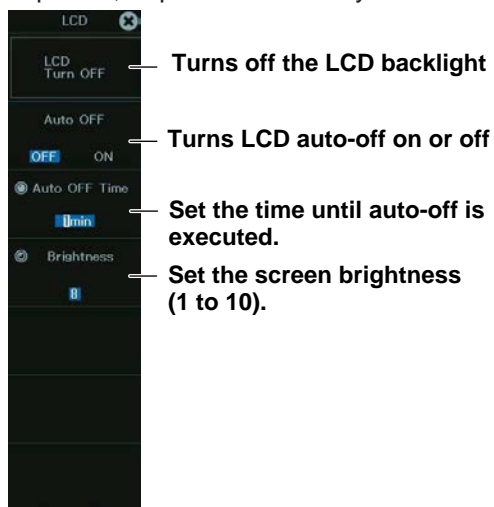

23.5 Using the Instrument as a USB Storage Device

This section explains the setting that enables you to use the instrument as a USB storage device through a USB connection made between the USB port on the instrument's side panel and a PC.

Items Common to Scope Mode and Recorder Mode

- Setting the USB function

► [“Remote Control \(Remote Ctrl\)” in the Features Guide](#)

UTILITY Remote Ctrl Menu

1. On the waveform screen's MENU, tap **OTHERS** > **UTILITY**, or press **UTILITY**.
2. Tap **Remote Ctrl**, or press the soft key. The following screen appears.

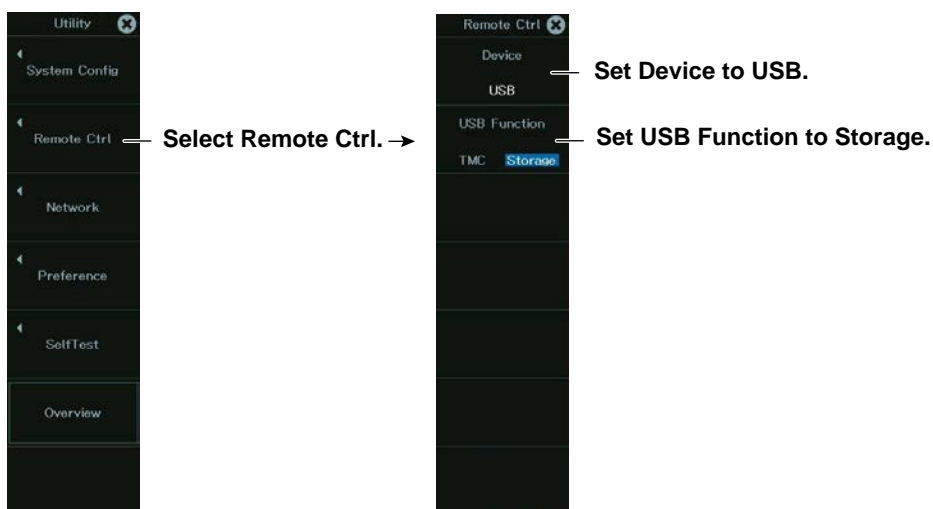

Note

- When USB Function is set to Storage, only this instrument's internal SSD can be used as a storage device. You cannot access any other storage device that are connected to the instrument.
- When you access this instrument's internal SSD from a PC, only perform read and write operations. Otherwise, the instrument may be damaged.
- When USB Function is set to Storage and files are being accessed, do not remove the USB cable or turn off the instrument. Otherwise, the instrument may be damaged.
- When USB Function is set to Storage, do not access this instrument's internal SSD from the instrument's menu.
- When you set USB Function to TMC, you can control this instrument from a PC via USB. For details, see the *Communication Interface User's Manual*, IM DL950-17EN, contained in the CD.

23.6 Configuring the Environment Settings

This section explains the following instrument settings:

Items Common to Scope Mode and Recorder Mode

- Power-on action
- Logic
- External I/O terminal
- Click sound on/off and key lock type and release method
- Beep on errors, backup when the power is turned off
- Turning the touch panel feature on and off

► [“Environment Settings \(Preference\)” in the Features Guide](#)

UTILITY Preference Menu (Preference)

1. On the waveform screen’s MENU, tap **OTHERS** > **UTILITY**, or press **UTILITY**.
2. Tap **Preference**, or press the soft key. The following screen appears.

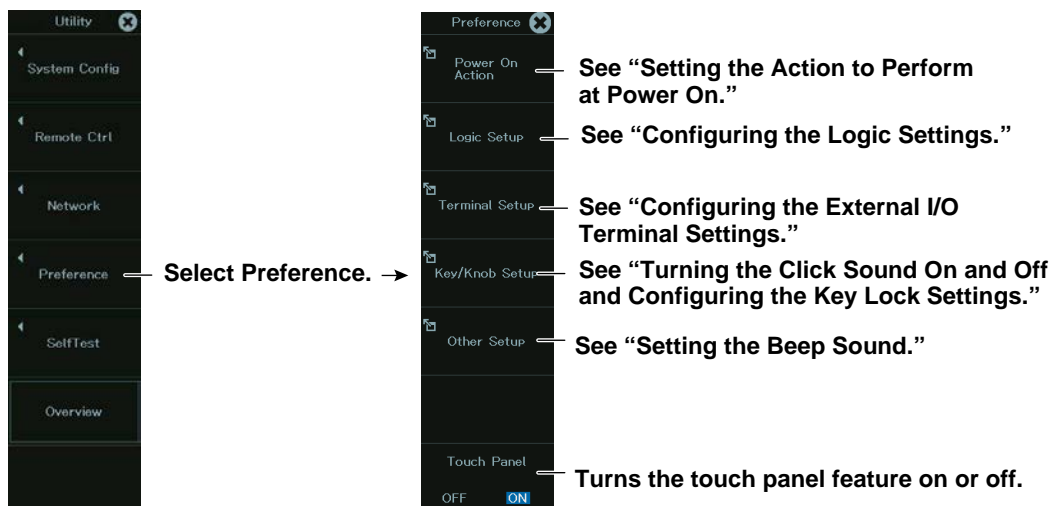

Setting the Action to Perform at Power On (Power On Action)

3. Tap **Power On Action**, or press the soft key. The following screen appears.

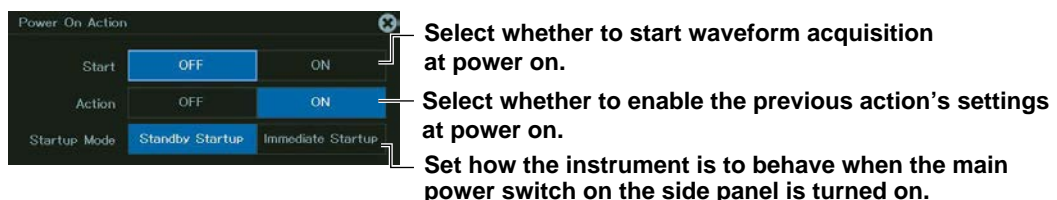

Startup Mode

Set how the instrument is to behave when the main power switch on this instrument’s side panel is turned on.

- Standby Startup: Stand by until the power switch on the front panel is turned on.
- Immediate Startup: Start the instrument.

Configuring the Logic Settings (Logic Setup)

3. Tap **Logic Setup**, or press the soft key. The following screen appears.

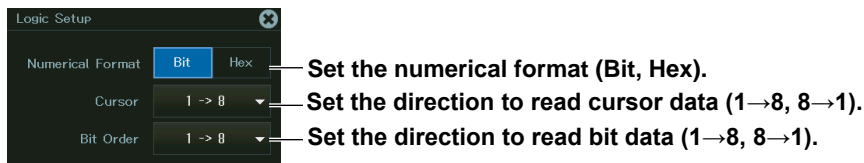

Configuring the External I/O Terminal Settings (Terminal Setup)

3. Tap **Terminal Setup**, or press the soft key. The following screen appears.

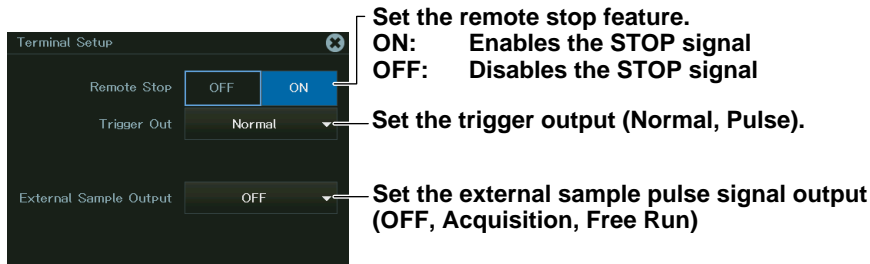

Turning the Click Sound On and Off and Configuring the Key Lock Settings (Key/Knob Setup)

3. Tap **Key/Knob Setup**, or press the soft key. The following screen appears.

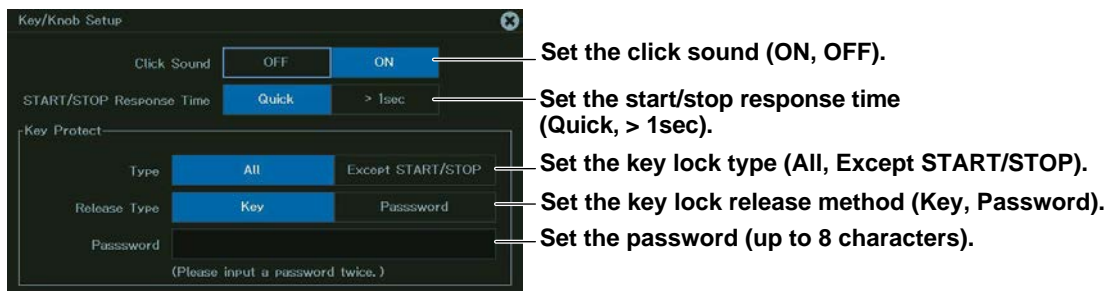

Start/Stop Response Time

Quick: Waveform acquisition starts or stops as soon as the START/STOP key is pressed.

1 s: Waveform acquisition starts or stops 1 second after the START/STOP key is pressed.

Key Lock Type

All: Key lock is applied to all keys except KEY PROTECT.

Except START/STOP: Key lock is applied to all keys except KEY PROTECT and START/STOP.

Releasing the Key Lock

Key: The key lock is released by pressing the KEY PROTECT key.

Password: The key lock is released with a password.

Setting the Beep Sound (Other Setup)

3. Tap **Other Setup**, or press the soft key. The following screen appears.

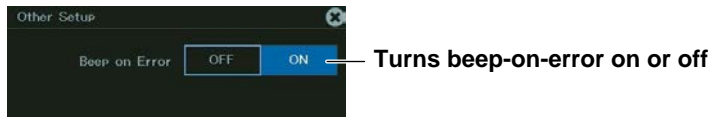

23.7 Locking the Keys

This section explains how to lock the panel keys, which prevents you from unintentionally changing the current state of the instrument.

Items Common to Scope Mode and Recorder Mode

- Key lock

▶ [“Key Lock \(KEY PROTECT key\)” in the Features Guide](#)

Key Lock (KEY PROTECT)

Press **KEY PROTECT** to lock the panel keys. The KEY PROTECT key illuminates. When you lock the keys, all keys except KEY PROTECT or all keys except KEY PROTECT and START/STOP, depending on the setting in section 23.6, are disabled.

To release the key lock, press **KEY PROTECT** again to turn off the key or enter the password set in section 23.6.

Note

When the keys are locked, you cannot use a USB mouse or keyboard to operate the instrument either.

Index

Index

Symbols Page

μ STR 2-24

Numerics Page

1-cycle mode 11-5

1 Record 9-2

10GSFP+ 20-3

1000BASE-T 20-2

A Page

ACCEL 2-26

accumulation 5-9

ACQUIRE 3-2

acquisition condition 3-5

acquisition count 3-2

acquisition method 3-5

Acquisition Mode 3-3

Acquisition Time 3-5

action 14-4, 15-2

A Delay B 4-13

All Record 9-2

All SubChannel Factor/Offset

 CAN 2-38

 LIN 2-43

 SENT 2-47

All SubChannel Setup

 CAN 2-37

 LIN 2-43

 SENT 2-47

 temperature 2-21

 voltage 2-14

AND trigger 4-17

APPLICATION 1-5

arc tangent 16-11

Area2 Mode 11-6

ASCII 19-11

Atan 16-11

A to B(N) 4-11

attenuation ratio 2-6

Auto

 dual capture 3-10

 trigger mode 4-2

Auto Level 4-2

auto-off 23-6

Auto Scroll

 recorder mode 7-7

 scope mode 7-3

auto setup 1-4

Average 3-3

Average(math) 13-5

Average Record 9-2

AX+B 2-10

B Page

bandwidth limit 2-6, 2-55

Bar 17-13

Basic 3-5

basic arithmetic 13-3, 16-4

beep sound 14-4, 15-3

bias current 2-26

Bin 13-3

binary 19-11

binary computation 13-3

brightness 23-6

burnout 2-19, 2-22

C Page

calibration 23-4

CAN 2-36

CAN FD 2-36

CAN Port Configuration 2-37

capture mode 3-10

Capture on Trigger 3-5

channel information 5-7

CLEAR TRACE 5-10

click sound 23-10

common logarithm 16-5

compression 19-13

Continuous 3-5

continuous statistic 11-7

cosine 16-9

CSV 19-11

current-to-voltage conversion ratio 2-6

cursor measurement

 FFT 12-8

 T-Y 10-2

 X-Y 6-4

Cursor Read Mode

 degree 10-8

 H & V 10-10

 maker 10-6

 vertical 10-4

cycle average 13-6

cycle statistic 11-8

D Page

DA 16-4

data type

 waveform 19-11

date and time search 8-8

DC offset cancellation 2-9

Degree 10-7

Delay 4-4

Detail Setup(display) 5-7

differentiation 16-5

Diff(S1) 16-5

digital filter 2-6, 2-55

display format 5-2, 19-24

display group 5-2

Display Result 11-9

distal value 11-5

DLC 2-41

DNS 20-6

dual capture 3-9

DUALCAPTURE 3-9

Duty 2-31

Index

N		Page
Network	20-5	
network drive	20-9	
network printer.....	18-2, 20-12	
Normal	3-3	
trigger mode	4-2	

O		Page
Offset	2-8	
One Shot Out.....	2-40	
On Start	3-10, 4-3	
OR trigger		
recorder mode.....	4-28	
scope mode.....	4-17	

P		Page
P1-P2.....	2-10	
parameter search	9-6	
Pattern Setup		
A Delay B	4-14	
AND.....	4-18	
A to B(N).....	4-12	
Edge On A.....	4-16	
OR	4-18	
period	4-20	
pulse width	4-22	
wave window.....	4-24	
peak computation	13-6	
peak cursor.....	12-10	
period.....	16-6	
Period	2-30	
period trigger	4-19	
phase shift	13-3	
Poly-Add-Sub	16-4	
Polynomial	16-4	
Port Setup.....	2-44	
power.....	16-8	
power analysis.....	17-2	
Power Analysis Item	17-6	
Power Freq.....	2-31	
power integration	16-8	
Power On Action.....	23-9	
P-P compression	19-13	
printing image	18-2	
Protect	19-27	
proximal value	11-5	
Pulse Integ.....	2-31	
pulse width.....	4-21	
Pulse Width	2-31	
PWM.....	16-7	

Q		Page
quartic polynomial.....	16-4	

R		Page
Range Setup.....	12-6	
real time math.....	16-2	
real-time recording.....	3-13	
recall	23-3	
recorder mode	1-2	
record length.....	3-2, 3-5	
releasing the key lock	23-11	
Rename	19-28	
resolver.....	16-18	
Revolution.....	2-30	
RJC.....	2-19, 2-22	

RMS.....	16-8
rotary angle.....	16-11
rotary speed.....	16-14

S		Page
sample interval	2-9, 3-5	
sample rate.....	2-9	
save		
FFT.....	19-17	
history.....	19-13	
measure	19-17	
setup data	19-16	
snap	19-17	
waveform.....	19-9	
save range.....	19-12	
saving screen capture	18-4	
scale value.....	5-7	
scope mode.....	1-2	
SD memory card.....	19-2	
search		
date and time	8-8	
edge	8-2	
event	8-5	
history waveform.....	9-4	
logic pattern.....	8-6	
SEARCH.....	8-2	
search condition	8-3	
Sensor Setup.....	2-24	
SENT	2-46	
SETUP.....	1-2	
Sharp.....	2-7, 2-56	
Shift	13-3	
shunt calibration	2-24	
simple average	13-5	
simple trigger		
edge	4-5	
external	4-8	
line.....	4-9	
logic.....	4-10	
time	4-7	
sine	16-9	
Single.....	4-2	
SingleN	4-3	
snapshot.....	5-10	
SNTP	20-11	
sort.....	19-24	
Sqrt1	16-6	
square root	16-6	
SSD recording	3-13	
SSD Recording.....	3-5	
Statistics	11-7, 11-10	
Storage	23-8	
store.....	23-2	
strain balance	2-23	
Sub Channel.....	2-16, 2-22, 2-39, 2-49	
Symbol File	2-39	
Symbol File Load.....	2-44	

T	Page
TC.....	2-22
TCP/IP.....	20-5
Temperature Setup.....	2-19, 2-22
Terminal Setup.....	23-10
thermocouple.....	2-22
Time Base.....	3-3
Timer.....	17-4
Time Range.....	11-5
Time Sync.....	21-2
time synchronization.....	21-2
time trigger	
recorder mode.....	4-27
scope mode.....	4-7
torque.....	16-7
touch panel.....	23-9
Transient.....	17-4
trigger delay.....	4-4
Trigger Mode.....	3-3, 4-2
trigger position.....	4-4
U	Page
Upper/ Lower.....	2-8
USB printer.....	18-3
USB storage.....	23-8
USB storage device.....	19-4
user-defined math.....	13-7
Utility.....	19-23
V	Page
Vector.....	17-13
Velocity.....	2-32
Vertical	
cursor(T-Y).....	10-3
cursor(X-Y).....	6-6
VERTICAL.....	2-3
vertical position.....	2-11
vertical scale.....	2-10
V Scale.....	2-8
V Zoom.....	2-8
W	Page
waveform parameter.....	11-2
wave window.....	4-23
WDF.....	19-11
web server.....	20-7
X	Page
X-Y.....	6-2
Z	Page
zone.....	14-2
zone search.....	9-5
ZOOM.....	7-2
zoom position.....	7-5