



Emitec Messtechnik AG
Birkenstrasse 47
6343 Rotkreuz

+41 41 748 60 10
info@emitec.ch
www.emitec-industrial.ch



Emitec Group 
#1 In Test & Measurement, worldwide.

DL950 ScopeCorder

USER'S MANUAL

Features Guide

Thank you for purchasing the DL950 ScopeCorder. This features guide contains useful information about the features of this instrument. To ensure correct use, please read this manual thoroughly before operation. After reading this manual, keep it in a safe place. The manuals for this instrument are listed on the next page. Please read all manuals.

Contact information of Yokogawa offices worldwide is provided on the following sheet.

Document No.	Description
PIM 113-01Z2	List of worldwide contacts

Notes

- The contents of this manual are subject to change without prior notice as a result of continuing improvements to the instrument's performance and functionality. The figures given in this manual may differ from those that actually appear on your screen.
- Every effort has been made in the preparation of this manual to ensure the accuracy of its contents. However, should you have any questions or find any errors, please contact your nearest YOKOGAWA dealer.
- Copying or reproducing all or any part of the contents of this manual without the permission of YOKOGAWA is strictly prohibited.
- The TCP/IP software of this product and the documents concerning it have been developed/created by YOKOGAWA based on the BSD Networking Software, Release 1 that has been licensed from the Regents of the University of California.

Trademarks

- Microsoft, Internet Explorer, Windows, Windows 8.1, and Windows 10 are registered trademarks or trademarks of Microsoft Corporation in the United States and/or other countries.
- Adobe and Acrobat are either registered trademarks or trademarks of Adobe Systems Incorporated.
- MATLAB is a registered trademark of The MathWorks, Inc. in the United States.
- GIGAZOOM ENGINE is a registered trademark of YOKOGAWA Electric Corporation.
- In this manual, the ® and TM symbols do not accompany their respective registered trademark or trademark names.
- Other company and product names are trademarks or registered trademarks of their respective holders.

Revisions

- 1st Edition: February 2021

Manuals

The following manuals, including this one, are provided as manuals for this instrument. Please read all manuals.

Manual Title	Manual No.	Description
DL950 ScopeCorder Features Guide	IM DL950-01EN	This document. The supplied CD contains the PDF file of this manual. This manual explains all the instrument's features other than the communication interface features.
DL950 ScopeCorder User's Manual	IM DL950-02EN	The supplied CD contains the PDF file of this manual. The manual explains how to operate this instrument.
DL950 ScopeCorder Getting Started Guide	IM DL950-03EN	Provided as a printed manual. This guide explains the handling precautions, common operations, troubleshooting measures, and specifications of this instrument.
DL950 ScopeCorder Communication Interface User's Manual	IM DL950-17EN	The supplied CD contains the PDF file of this manual. Explains the functions of the this instrument's communication interface, how to configure it, and the commands used to control this instrument from a PC through the interface.
Precautions Concerning the Modules	IM 701250-04	The manual explains the precautions concerning the modules. This manual is included if you ordered modules.
DL950 ScopeCorder	IM DL950-92Z1	Document for China

The "EN", "E", and "Z1" in the manual numbers are the language codes.

Manuals in the CD

The included CD (manual CD) contains the following English and Japanese manuals.

File Name	Manual No.	Description
Features Guide & Users Manual.pdf	IM DL950-01EN IM DL950-02EN	Features Guide and User's Manual
Communication Interface.pdf	IM DL950-17EN	Communication Interface User's Manual

Online Help

The content similar to the Features Guide, IM DL950-01EN, is included in this instrument as a help file (some the content may be omitted). For instructions on how to use the help, see section 4.11 in the *Getting Started Guide*, IM DL950-03EN.

Contents

Manuels	ii
1 Setup	
Initializing Settings to Default (Initialize)	1-1
Auto Setup (Auto Setup)	1-1
Operation Mode (Recorder Mode Switch/Scope Mode Switch)	1-2
Application (APPLICATION)	1-2
2 Channel Setup	
Input Settings	2-1
Voltage Measurement	2-2
Vertical Scale (SCALE knob)	2-3
Input Coupling (Coupling)	2-6
Probe Attenuation and Current-to-Voltage Conversion Ratio (Probe)	2-7
Bandwidth Limit (Bandwidth)	2-8
Assignments to Display Groups (Display)	2-10
Zoom Method (V Scale)	2-10
Waveform Vertical Position (Vertical POSITION knob)	2-10
Magnification for Zooming (V Zoom) and Offset (V Zoom/Offset)	2-11
Zooming by Setting Upper and Lower Display Limits (Upper/Lower)	2-13
Input Signal Adjustment (Adjustment)	2-14
Inverted Waveform Display (Invert)	2-15
Sample Rate (Sample Rate), Sample Interval (Sample Interval)	2-15
Linear Scaling (Linear Scale)	2-16
RMS Measurement	2-18
Temperature Measurement	2-19
Temperature Measurement (For the 16-CH Temperature/Voltage Input Module)	2-21
Notes about Using the 16-CH Temperature/Voltage Input Module (720221)	2-24
Strain Measurement	2-25
Shunt Calibration (Only on the 701271 (STRAIN_DSUB))	2-28
Acceleration Measurement	2-30
Frequency Measurement	2-32
FV Setup (FV Setup) - frequency measurement	2-32
Input Setup (Input Setup) - Frequency Measurement	2-38
Logic Measurement	2-41
CAN and CAN FD Bus Signal Monitoring (/VCE option)	2-43
Reading Data Frames (CAN Port Configuration)	2-46
CAN/CAN FD Data Display Settings (Sub Channel)	2-49
One Shot Output Settings (One shot out Setup)	2-50
All Sub Channel Scale (All SubChannel Scale)	2-50
LIN Bus Signal Monitoring (/VCE option)	2-51
Reading LIN Frames (LIN Port Configuration)	2-52
LIN Data Display Settings (Sub Channel)	2-54
SENT Signal Monitoring (/VCE option)	2-55
Reading SENT Messages (SENT Port Configuration)	2-56
SENT Data Extraction Conditions (All Sub Channel Setup)	2-59
SENT Data Conversion Conditions (All Sub Channel Factor/Offset)	2-62
SENT Data Display Settings (Sub Channel)	2-62
Displaying the Menu for Configuring All Channels (ALL CH)	2-63
Digital Filter (Filter)/G03, /G05 option)	2-65

3	Waveform Acquisition	
	Operation Modes and Settings	3-1
	Time Scale (TIME/DIV knob)	3-2
	Record length (Record Length).....	3-5
	Acquisition Mode (Acquisition Mode).....	3-7
	Trigger Mode (Trigger Mode).....	3-8
	Acquisition Count (Acquisition Count).....	3-9
	SSD Recording (SSD recording, /ST1 option).....	3-9
	Time Base (Time Base)	3-11
	Dual Capture (DUAL CAPTURE, Scope mode only).....	3-13
	Basic Recorder Mode Setup (Basic).....	3-15
	Detailed Recorder Mode Setup (Detail).....	3-16
	Waveform Acquisition (START/STOP).....	3-17
4	Trigger	
	Trigger Settings (Setting)	4-1
	Trigger Type (Type).....	4-1
	Signal Type and Trigger Type Combinations	4-2
	Basic Trigger Settings	4-2
	Simple Trigger (Simple)	4-3
	Trigger Source (Source)	4-3
	Trigger Level (Level)	4-4
	Trigger Slope (Slope).....	4-5
	Trigger Hysteresis (Hysteresis).....	4-5
	Trigger Position (Position).....	4-5
	Trigger Hold-off (Hold Off).....	4-7
	Trigger Delay (Delay Time)	4-7
	Pre-Trigger (Pre Trigger).....	4-8
	Unit Setting (Unit Setting)	4-8
	A to B (N) Trigger (Enhanced).....	4-9
	A Delay B Trigger (Enhanced)	4-10
	Edge On A Trigger (Enhanced).....	4-11
	OR Trigger (Enhanced).....	4-12
	AND Trigger (Enhanced).....	4-13
	Period Trigger (Enhanced).....	4-14
	Pulse Width Trigger (Enhanced).....	4-15
	Wave Window Trigger (Enhanced)	4-16
	Edge Trigger (Edge).....	4-19
	Time Trigger (Time).....	4-19
5	Display	
	Window Types (DISPLAY)	5-1
	Group Selection (Select Group).....	5-2
	Display Format (Format).....	5-2
	Grid (Graticule)	5-2
	Detail Setup (Detail Setup)	5-3
	Interpolation Method (Dot Connect).....	5-5
	Display Group Setup (Display Group Setup)	5-6
	Accumulation (Accumulate)	5-7
	Low-Speed Sampling Display Ratio (Low Speed Display Ratio).....	5-7

6	X-Y Waveform Display	
	X-Y Window Selection (Window Select)	6-1
	X-Y Window Display ON/OFF (Display).....	6-1
	X-Y Waveform Setup (Setup).....	6-1
	Start Point and End Point (Start Point/End Point).....	6-2
	Pen Marker (Pen Marker)	6-2
	X-Y Waveform Cursor Measurement (Cursor).....	6-2
	Display Ratio of the Main Window (Main Ratio).....	6-5
	Window Layout (Window Layout)	6-5
	Combine Display (Combine Display)	6-5
	Interpolation Method (Dot Connect).....	6-6
	Number of Data Points to Use for Waveform Display (Decimation)	6-6
	Clearing Waveforms at Acquisition Start (Trace Clear on Start).....	6-6
7	Zooming In on or Out of Waveforms	
	Zoom Window Selection (Window).....	7-2
	Zoom Window Display ON/OFF (Display)	7-2
	Zoom Source Window (Zoom2 Source).....	7-2
	Zoom Factor (MAG knob)	7-2
	Zoom Position (Zoom Position*) (zoom POSITION knob).....	7-3
	Setting the Waveform Display Section in Recorder Mode	7-3
	Display Format (Format*).....	7-4
	Moving the Zoom Position to the Right Edge (Move to Front*).....	7-4
	Display Ratio of the Main Window (Main Ratio).....	7-4
	Window Layout (Window Layout)	7-4
	Auto Scrolling (Auto Scroll).....	7-5
	Waveforms That Are Zoomed (Allocation).....	7-5
	Change the Range for Performing Automated Measurement of Waveform Parameters (Fit Measure Range)	7-5
8	Searching Waveforms	
	Search Type (Type).....	8-1
	Edge Search (Edge)	8-1
	Event Search (Event).....	8-4
	Logic Pattern Search (Logic Pattern).....	8-4
	Time Search (Time)	8-5
	Notes about Searching Waveforms	8-5
9	History Waveform Display/Search (Scope mode only)	
	Display Mode (Display Mode).....	9-2
	Highlighting (Selected Record)	9-2
	Display Range (Start and End Record).....	9-3
	List of History Waveforms (List)	9-3
	History Waveform Search Mode (Search Mode)	9-3
	Search Conditions for Zone Searching (Search Setup).....	9-4
	Search Conditions for Waveform Parameter Searching (Search Setup).....	9-4
	Executing a Search (Execute)	9-5
	Clearing History Waveforms (Clear History)	9-5
	Notes on Using the History Feature.....	9-5
	Displaying High-Speed Sampling Waveforms of Dual Capture	9-6

10	Cursor Measurement	
	Cursor Measurement ON/OFF (Mode)	10-1
	Horizontal Cursors (Horizontal)	10-1
	Vertical Cursors (Vertical)	10-2
	Marker Cursors (Marker)	10-4
	Angle Cursors (Degree)	10-6
	Horizontal and Vertical Cursors (H & V).....	10-7
	Notes about Cursor Measurement.....	10-9
11	Automated Measurement of Waveform Parameters	
	Turning Automated Measurement of Waveform Parameters On and Off (Mode).....	11-1
	Measurement Items (Measure Setup)	11-1
	Delay Setup (Delay Setup)	11-4
	Measurement Time Period (Time Range1/Time Range2)	11-5
	Parameter Details (Detail).....	11-6
	Measurement Location Indicator (Indicator)	11-7
	Extended Parameter Measurement (Area2 Mode).....	11-8
	Low-Speed Sampling Waveform Measurement (Low Speed Measure).....	11-8
	Notes about Automated Measurement of Waveform Parameters	11-9
	Statistics (Statistics).....	11-9
	Continuous Statistical Processing (Continuous).....	11-10
	Cyclic Statistical Processing (Cycle).....	11-10
	Statistical Processing of History Waveforms (History).....	11-12
	Notes about Statistical Processing	11-13
12	FFT	
	All Math Setup (FFT Setup)	12-1
	Math Range Setup (Range Setup).....	12-3
	FFT Trace Setup (Trace Setup)	12-4
	FFT Math Setup (FFT Math Setup).....	12-5
	FFT Waveform Cursor Measurement (Cursor)	12-6
	Marker Cursors (Marker).....	12-6
	Peak Cursors (Peak).....	12-7
	Display Ratio of the Main Window (Main Ratio).....	12-7
	Window Layout (Window Layout)	12-7
	Combine Display (Combine Display)	12-7
	Window Display Setup (Window Display Setup).....	12-7
	Average Setup (Average Setup)/(G02 option)	12-8
	Notes about FFT Computation.....	12-9
13	Math	
	Math ON/OFF (Mode).....	13-1
	Math Setup (Setup).....	13-1
	Math Trace Selection (Select Math Trace).....	13-3
	Scaling Mode (Scaling).....	13-3
	Start Point and End Point (Start Point/End Point).....	13-3
	User-Defined Math Function (User Define)/(G02 option).....	13-3
	Expression (Expression) (/G02 option)	13-4
	Average Setup (Average Setup)/(G02 option)	13-6
	Notes about Computation	13-7

14	GO/NO-GO Determination (Scope mode only)	
	GO/NO-GO ON/OFF Determination (Mode).....	14-1
	Determination Type Selection (Type).....	14-1
	Waveform Zone (Wave Zone).....	14-2
	Waveform Parameter (Parameter).....	14-4
	Notes about GO/NO-GO Determination	14-5
15	Actions	
	Settings	15-1
	Action Mode (Mode).....	15-1
	Action Setup (Action Setup).....	15-1
	Save on Stop (Save on Stop)	15-3
	Save on Stop Setup (Save on Stop Setup)	15-3
	Notes about Action.....	15-3
16	Real Time Math (/G03, /G05 option)	
	Real Time Math Channel ON/OFF (Input)	16-1
	Real Time Math Setup (RealTime Math Setup)	16-3
	Basic Arithmetic with Coefficients $A(S1)+B(S2)+C$, $A(S1)-B(S2)+C$, $A(S1)*B(S2)+C$, $A(S1)/$ $B(S2)+C$	16-4
	Differentiation (Diff(S1)).....	16-4
	Integration (Integ1(S1) and Integ2(S1)).....	16-5
	Angle of Rotation (Rotary Angle).....	16-5
	Rotating Speed (Rotary Speed)	16-8
	Logic Signal and Analog Waveform Conversion (DA)	16-10
	Quartic Polynomial (Polynomial)	16-10
	RMS Value (RMS)	16-11
	Effective Power (Power).....	16-12
	Effective Power Integration (Power Integ).....	16-12
	Common Logarithm (Log1 and Log2).....	16-13
	Square Root (Sqrt1 and Sqrt2).....	16-13
	Cosine (Cos) and Sine (Sin).....	16-14
	Arc Tangent (Atan).....	16-14
	Electrical Angle (Electrical Angle).....	16-15
	Knocking Filter (Knock Filter) (/VCE option).....	16-16
	Polynomial (Poly-Add-Sub)	16-16
	Frequency (Frequency)	16-17
	Period (Period)	16-17
	Edge Count (Edge Count)	16-18
	Resolver (Resolver).....	16-18
	Demodulation of the Pulse Width Modulated Signal (PWM)	16-19
	Torque (Torque).....	16-20
	3 Phase Resolver (3 Phase Resolver)	16-21
	Notes Regarding Using the Digital Filter and Real Time Math.....	16-22

17	Power Math (/G05 option)	
	Power Analysis (Power).....	17-1
	Analysis Mode (Analysis Mode).....	17-4
	Wiring System (Wiring).....	17-4
	Math Source Waveforms (U1 to U3, I1 to I3).....	17-8
	Detailed Analysis Setting (Detail).....	17-8
	Analysis Setting (Analysis Setting).....	17-9
	Efficiency Setting (Efficiency Setting).....	17-10
	Power Analysis Items (Power Analysis Item).....	17-10
	Harmonic Analysis (Harmonics).....	17-11
	Analysis Mode (Analysis Mode).....	17-12
	Math Source Waveform (Source).....	17-12
	Calculation Period (Calc Period).....	17-12
	ϕ Scaling (ϕ Scale).....	17-12
	Harmonic Analysis Items (Power Analysis Item).....	17-13
	Harmonic Analysis Window Setup (Window Setup).....	17-13
	When the Type Is Set to Bar Graph.....	17-14
	When the Type Is Set to List.....	17-15
	When the Type Is Set to Vector.....	17-16
	Numeric Monitor Mode (Digital Monitor Mode).....	17-16
18	Printing and Saving Screen Captures	
	Target (Target).....	18-1
	Printing on a USB Printer (USB Print).....	18-1
	Printing on a Network Printer (Network Print).....	18-2
	Saving Screen Captures to Files (File).....	18-3
	Printing and Saving Screen Captures (IMAGE SAVE key).....	18-3
19	Saving and Loading Data	
	Storage Device You Can Save and Load From.....	19-1
	Saving Waveform Data (Waveform).....	19-2
	Saving Setup Data (Setup).....	19-7
	Saving Other Types of Data (Others).....	19-7
	Saving Data (SAVE key).....	19-9
	Loading Data (Load).....	19-10
	File Operations (Utility).....	19-11
20	Ethernet Communication (Network)	
	TCP/IP10G (TCP/IP10G), TCP/IP (TCP/IP).....	20-2
	FTP Server (FTP/Web Server).....	20-3
	Web Server (FTP/Web Server).....	20-4
	Mail (Mail).....	20-5
	Network Printer (Net Print).....	20-6
	Network Drive (Net Drive).....	20-6
	SNTP (SNTP).....	20-7
21	Time Synchronization	
	Time Synchronization Method (Time Sync).....	21-1
	IEEE1588 Setup (IEEE1588 Setup).....	21-2
	IRIG Configuration (System Configuration).....	21-3

22	Synchronizing Multiple Instruments (/C50 option)	
	Multi-Unit Synchronization Setup (Multi Unit Sync.)	22-1
	Notes on Synchronous Operation	22-2
23	Other Features	
	Setup Data Store/Recall (Store/Recall)	23-1
	Calibration (CAL)	23-1
	Power Integration Calibration (/G05 option).....	23-1
	Snapshot (SNAPSHOT).....	23-2
	Clear Trace (CLEAR TRACE).....	23-2
	Remote Control (Remote Ctrl).....	23-2
	System Configuration (System Config).....	23-4
	Environment Settings (Preference).....	23-6
	Self-test (SelfTest).....	23-8
	Overview (Overview).....	23-9
	Key Lock (KEY PROTECT key).....	23-9

Appendix

Appendix 1	How to Calculate the Area of a Waveform.....	App-1
Appendix 2	User-Defined Math Function (/G02 option)	App-3
	FFT Function - user-defined	App-7
Appendix 3	ASCII Data File Format	App-13
Appendix 4	Fundamental Equations for Defining Strain.....	App-14
Appendix 5	Strain Shunt Calibration	App-15
Appendix 6	Frequency Module's Math Expression and Smoothing Filter's Filter Response	App-20
Appendix 7	List of Preset Settings of the Frequency Module.....	App-22
Appendix 8	TCP and UDP Port Numbers.....	App-25
Appendix 9	Firmware Version and New Features	App-26
Appendix 10	Using Data Files (WDF Files).....	App-27
Appendix 11	Digital Filter and Real Time Math	App-32
Appendix 12	Equations for Power Analysis and Harmonic Analysis	App-61
Appendix 13	Data Acquisition of Power Analysis Results and Harmonic Analysis Results....	App-75
Appendix 14	Power Basics (Power, harmonics, and AC RLC circuits)	App-76

Index

1 Setup

SETUP Menu

You can specify the following items.

- [Initialize \(Initialize\)](#)
- [Auto setup \(Auto Setup\)](#)
- [Change the operation mode \(Recorder Mode Switch/Scope Mode Switch\)](#)
- [Multi-unit synchronization setup \(Multi Unit Sync.\)](#) (Chapter 22)
- [Storing and recalling setup data \(Store and Recall\)](#) (Chapter 23)

APPLICATION Menu

▶ [See here.](#)

Initializing Settings to Default (Initialize)

You can reset the instrument settings to their factory default values. This feature is useful when you want to cancel all the settings that you have entered or when you want to redo measurements from scratch.

Items That Cannot Be Reset

The following settings cannot be reset.

Date and time, communication, language, startup mode, operation mode (Scope mode or Recorder mode), favorites in the application menu, environment

Canceling Initialization

You can cancel initialization on the confirmation screen before execution. If you select OK on the confirmation screen, initialization will be executed, and you will not be able to cancel.

To Reset All Settings to Their Default Values

While holding down the RESET key, turn the power switch on. All settings except the date and time settings (display on/off setting will be reset), startup mode setting, and the setup data stored in internal memory will be reset to their factory default values. If you reset the settings in this manner, you will not be able to go back to the original settings.

Auto Setup (Auto Setup)

The auto setup feature automatically sets the vertical scale (SCALE), horizontal scale (TIME/DIV), trigger level, and other settings to the most suitable values for the input signals. This feature is useful when you are not sure what type of signal will be applied to the instrument. The auto setup feature will not work properly on some input signals. There are some modules with which the auto setup feature cannot be used.

Center Position after the Execution of Auto Setup

The center position after you execute auto setup will be 0 V.

Applicable Modules

720256(4CH10M16), 701250(HS10M12), 720250(HS10M12), 701251(HS1M16), 701255(NONISO_10M12), 720268(HV(AAF, RMS)), 701261(UNIVERSAL), 701262(UNIVERSAL(AAF)), 701275(ACCL/VOLT), 720212(HS200M14), 720211(HS100M12), 720254(4CH 1M16)

Target Channels

Auto setup is performed on all channels.

Waveforms Displayed before the Execution of Auto Setup

Waveforms that were displayed before you execute auto setup will be cleared.

Signals That Auto Setup Can Be Applied To

You can use auto setup for the following types of input signals.

- When a 720212 or 720211 module is installed: Simple, repeating signals with frequencies between approximately 50 Hz and 10 MHz
When a 720212 nor 720211 module is installed: Simple, repeating signals with frequencies between approximately 50 Hz and 1 MHz
- Signals whose maximum absolute input voltage is 20 mV at 1:1 probe attenuation to the maximum range × 10



- The auto setup feature may not work properly for signals that include a DC component or high-frequency components.
 - In Recorder mode, horizontal axis settings are not changed.
-

Canceling Auto Setup

You can cancel auto setup on the confirmation screen before execution. If you select OK on the confirmation screen, auto setup will be executed, and you will not be able to cancel.

Operation Mode (Recorder Mode Switch/Scope Mode Switch)

Switches between Scope mode and Recorder mode.

Scope Mode (Scope Mode)

Scope mode is used to set the time axis using Time/Div and record length. This is the typical time scale setting method for oscilloscopes.

Recorder Mode

Recorder mode is used to set the time axis using the measurement time and sampling interval. This is the typical time scale setting method for recorders.

Application (APPLICATION)

Pressing APPLICATION shows the application menu.

The application menu is a feature that supports instrument configuration such as measurement conditions. Even for measurements with numerous settings, settings can be appropriately configured without omissions as they can be set in order in a tutorial format.

Various applications are available such as power analysis configuration and easy recording configuration. In addition, you can register applications that you frequently use from the available applications in favorites as well as load setup data that you stored through the SETUP menu.

Edit Favorites (Edit Favorites)

A screen appears for registering applications in favorites. Up to five applications can be registered. Tapping “register screen in favorites” (rectangular box) shows a screen for selecting applications, and you can register applications that you use frequently.

To finish screen registration, tap Back (Back).

Registered applications appear in the favorites area at the top area of the application menu.

2 Channel Setup

This section explains how to configure the signal input settings and the amplitude-direction display settings. The items that can be set vary depending on the installed modules.

Input Settings

CH

The CH menu appears. Select the channel you want to configure using the up and down keys and then specify the vertical scale settings.

ALL CH

You can configure the settings of all channels while viewing the settings in a list. You can also copy the various vertical axis settings of one channel to another channel. Note that there are some items that cannot be configured from the ALL CH menu.

▶ [See here.](#)

Measurement Items

When you install the following modules into this instrument, it can measure voltage, temperature, strain, acceleration, frequency, logic, CAN bus signals, CAN FD bus signals LIN bus signals, SENT signals, and so on.

- **Voltage**
720256 (4CH10M16), 701250 (HS10M12), 720250 (HS10M12), 701251 (HS1M16), 701255 (NONISO_10M12), 720268 (HV (AAF, RMS)), 720212 (HS200M14), 720211 (HS100M12), 701261 (UNIVERSAL), 701262 (UNIVERSAL (AAF)), 701265 (TEMP/HPV), 720266 (TEMP/HPV), 701275 (ACCL/VOLT), 720254 (4CH 1M16)
- **Temperature**
701261 (UNIVERSAL), 701262 (UNIVERSAL (AAF)), 701265 (TEMP/HPV), 720266 (TEMP/HPV)
- **Temperature (for the 16-CH Temperature/Voltage Input Module)**
720221 (16CH TEMP/VOLT)
- **Strain**
701270 (STRAIN_NDIS), 701271 (STRAIN_DSUB)
- **Acceleration**
701275 (ACCL/VOLT)
- **Frequency**
701281 (FREQ), 720281 (FREQ)
- **Logic**
720230 (LOGIC)
- **CAN Bus Signal Monitoring**
720240 (CAN MONITOR), 720242 (CAN/CAN FD), 720241 (CAN & LIN)
These can only be used with the /VCE option. You can install up to a total of two 720240, 720241, or 720242 modules in slots 7 and 8.
- **CAN FD Bus Signal Monitoring**
720242 (CAN/CAN FD)
These can only be used with the /VCE option. You can install up to two 720242 modules in slots 7 and 8.
- **LIN Bus Signal Monitoring**
720241 (CAN & LIN)
This can only be used with the /VCE option. You can install up to a total of two 720241 modules in slots 7 and 8.
- **SENT Signal Monitoring**
720243 (SENT)
This can only be used with the /VCE option. You can install up to four 720243 modules in slots 5 to 8.



You can use auto setup to automatically configure the appropriate settings (such as vertical axis, horizontal axis, and trigger settings) for the input signal. This feature is useful when you are not sure what type of signal will be applied to the instrument. The auto setup feature will not work properly on some input signals. Also, there are some modules with which the auto setup feature cannot be used. ▶ [See here.](#)

Digital Filter (/G03, /G05 option) ▶ [See here.](#)

Real Time Math (/G03, /G05 option) ▶ [See here.](#)

Voltage Measurement

For voltage measurement, the items that have to be set for each input signal (CH1 to CH16) include vertical scales, vertical positions, input coupling, probe attenuation, bandwidth limit, zoom method, offset, waveform inversion, sample rate or sample interval, assignments to display groups, and linear scaling.

You can measure voltage by connecting probes, measurement leads, and so on to any of the following voltage measurement modules: 720256 (4CH10M16), 701250 (HS10M12), 720250 (HS10M12), 701251 (HS1M16), 701255 (NONISO_10M12), 720268 (HV (AAF, RMS), 720212 (HS200M14), 720211 (HS100M12), 701261 (UNIVERSAL), 701262 (UNIVERSAL (AAF)), 701265 (TEMP/HPV), 720266 (TEMP/HPV), 701275 (ACCL/VOLT), 720254 (4CH 1M16).

For the probe connection method, see section 3.6 in the *Getting Started Guide*, IM DL950-03EN. For the measurement lead connection method, see section 3.8.

- [Source Trace Selection](#)
- [Waveform Input ON/OFF \(Input\)](#)
- [Label \(Label\)](#)
- [Vertical Scale \(SCALE knob\)](#)
- [Input Coupling \(Coupling\)](#)
- [Probe Attenuation and Current-to-Voltage Conversion Ratio \(Probe\)](#)
- [Bandwidth Limit \(Bandwidth\), Digital Filter \(Filter\)](#)
- [Assignments to Display Groups \(Display\)](#)
- [Zoom Method \(V Scale\)](#)

When the Zoom Method is Set to DIV

- [Waveform Vertical Position \(Vertical POSITION knob\)](#)
- [Magnification for Zooming \(V Zoom\) and Offset \(V Zoom/Offset\)](#)
 - [Vertical Zoom \(V Zoom\)](#)
 - [Offset \(Offset\)](#)

When the Zoom Method is Set to SPAN

- [Zooming by Setting Upper and Lower Display Limits \(Upper/Lower\)](#)
- [Adjustment \(Adjustment\)](#)
 - [DC Offset Cancellation \(DC Offset Cancel\)](#)
 - [Gain Adjustment \(Gain Adjustment\)](#)
 - [Deskewing \(Skew Adjustment\)](#)
- [Inverted Waveform Display \(Invert\)](#)
- [Sample Rate \(Sample Rate\), Sample Interval \(Sample Interval\)](#)
- [Linear Scaling \(Linear Scale\)](#)
- [RMS Measurement](#)

Source Trace Selection

Select the source you want to configure from CH1 to CH16.

When you open the CH menu, a trace selection screen appears to the left of the setup menu.

In the case of a 720256 or 720254 4CH module, sub channels appear in the tray selection screen.*

In the case of a 720221 16CH module, select a main channel and then select the sub channel (Sub Channel) within the CH menu.

- * 4CH modules have sub channels 1 and 2. Sub channel 1 is displayed as "Channel number_1," and sub channel 2 as "Channel number_2." For example, sub channels are displayed as CH3_1 and CH3_2.

Waveform Input ON/OFF (Input)

You can set whether to acquire input signal waveforms for each channel.

- ON: Waveforms are acquired.
- OFF: Waveforms are not acquired.

Label (Label)

You can specify a name consisting of up to sixteen characters for each channel.

The labels that you set are reflected in scale values, trace labels, numeric monitor (DMM), and measured values of waveform parameters and cursors.

Vertical Scale (SCALE knob)**Vertical Scale (Voltage Scale) Setup**

The vertical scale is used to adjust the displayed waveform amplitude so that you can easily view signals.

Set the vertical scale using the SCALE knob for each main and sub channel. [▶ See here.](#)

The vertical scale changes when you switch to an input attenuator with a different attenuation.

Scope Mode (V/div)

Set the vertical scale by voltage per grid square (V/div) or current per grid square (A/div) on the screen. You can change the scale in steps like this: 1 V/div -> 2 V/div -> 5 V/div.

Recorder Mode (Full Range)

Set the vertical scale by specifying the voltage (V) or current (A) from the top edge to the bottom edge of the waveform screen. You can change the scale in steps like this: 10 V -> 20 V -> 50 V.

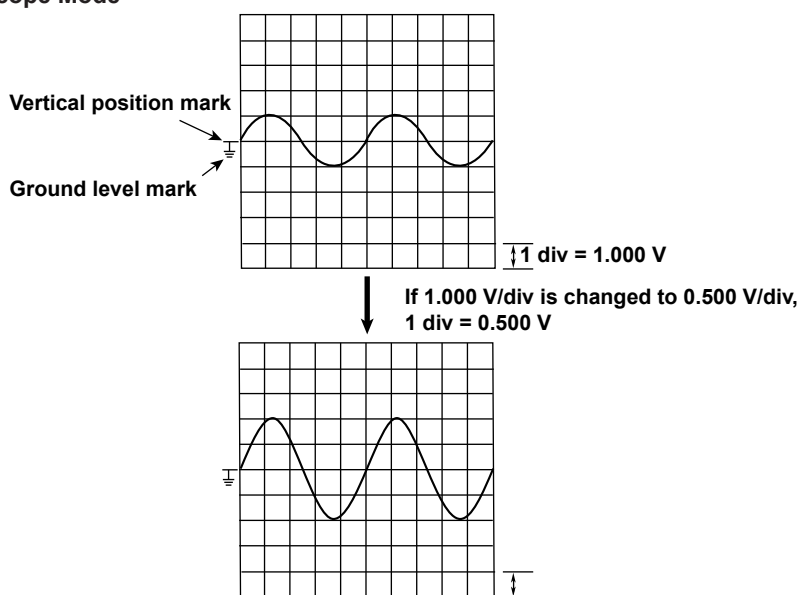
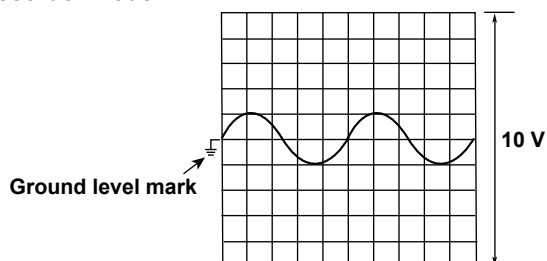
Setup Example**Scope Mode****Recorder Mode**

2 Channel Setup



- While waveform acquisition is stopped, turning the SCALE knob will not change the displayed waveform. This value will be applied the next time you restart waveform acquisition.
 - While waveform acquisition is stopped, turning the SCALE knob will not change the cursor-measurement values or the automated measurement values of waveform parameters, they will continue to be based on the V/div value at the time of measurement.
-

Vertical Scale (Voltage Scale) Setting Range

The selectable range varies as shown below depending on the input module. The values in the following table are for when the probe attenuation is 1:1. Multiply the values by 10 when the attenuation is 10:1, by 100 when the attenuation is 100:1, and by 1000 when the attenuation is 1000:1.

Scope Mode

Input Module	Selectable Range
720256 (4CH10M16), 701250 (HS10M12), 720250 (HS10M12)	5 mV/div to 20 V/div
701251 (HS1M16)	1 mV/div to 20 V/div
701255 (NONISO_10M12)	5 mV/div to 20 V/div
720268 (HV (AAF, RMS))	20 mV/div to 200 V/div
701261 (UNIVERSAL)	5 mV/div to 20 V/div
701262 (UNIVERSAL (AAF))	5 mV/div to 20 V/div
701265 (TEMP/HPV)	0.1 mV/div to 10 V/div
720266 (TEMP/HPV)	0.1 mV/div to 20 V/div
701275 (ACCL/VOLT)	5 mV/div to 10 V/div
720212 (HS200M14), 720211 (HS100M12)	10 mV/div to 20 V/div
720221 (16CH TEMP/VOLT)	1 mV/div to 2 V/div
720254 (4CH 1M16)	10 mV/div to 50 V/div

Recorder Mode

Input Module	Selectable Range
720256 (4CH10M16), 701250 (HS10M12), 720250 (HS10M12)	50 mV to 200 V
701251 (HS1M16)	10 mV to 200 V
701255 (NONISO_10M12)	50 mV to 200 V
720268 (HV (AAF, RMS))	200 mV to 2000 V
701261 (UNIVERSAL)	50 mV to 200 V
701262 (UNIVERSAL (AAF))	50 mV to 200 V
701265 (TEMP/HPV)	1 mV to 100 V
720266 (TEMP/HPV)	1 mV to 200 V
701275 (ACCL/VOLT)	50 mV to 100 V
720212 (HS200M14), 720211 (HS100M12)	100 mV to 200 V
720221 (16CH TEMP/VOLT)	10 mV to 20 V
720254 (4CH 1M16)	100 mV to 500 V

Measurement and Display Ranges

The measurement range of this instrument is $0\text{ V} \pm 10\text{ div}$ (the absolute width, or span, is 20 div). The default display-range setting is $\pm 5\text{ div}$ (the span is 10 div). Using the features listed below, you can move and scale the displayed waveform so that parts of it that were outside of the display range are displayed.

- Move the vertical position (Scope mode only)
- Set the offset voltage (Scope mode only)
- Vertical zoom

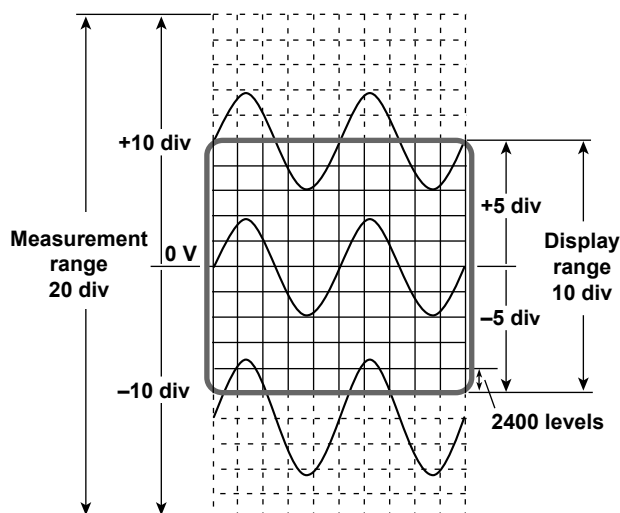

• How to Measure the Voltage with High Accuracy

To measure the voltage with high accuracy, increase the vertical scale so that the input signal is measured with the largest possible amplitude. To display multiple waveforms so that they do not overlap without dividing the screen, you have to set the vertical scale to a low value. This prevents you from taking advantage of the A/D converter's resolution. However, if you [divide the screen](#) and [arrange](#) the waveforms in the divided screens, they will not overlap, and you can increase the vertical sensitivity.

• Measurement Resolution

The measurement resolution varies depending on the module. For example, the 701250 (HS10M12), 720250 (HS10M12), 701255 (NONISO_10M12), and 720211 (HS100M12) use 12-bit A/D converters and sample the input signal at a resolution of 150 levels per div. The 720212 (HS200M14) uses 14-bit A/D converters and sample the input signal at a resolution of 600 levels per div. The 720256 (4CH10M16), 701251 (HS1M16), 720268 (HV (AAF, RMS)), 701261 (UNIVERSAL), 701262 (UNIVERSAL (AAF)), 701265 (TEMP/HPV), 720266 (TEMP/HPV), 701275 (ACCL/VOLT), 720221 (16CH TEMP/VOLT), and 720254 (4CH 1M16) use 16-bit A/D converters and sample the input signal at a resolution of 2400 levels per div.

Input Coupling (Coupling)

It is easier to measure the amplitude of an AC signal if you remove its DC component. On the other hand, there are times when you want to measure the ground level or observe the entire signal, including both the DC and AC components. In these kinds of situations, you can change the input coupling setting. By changing the setting, you can choose how the vertical (voltage) control circuit is coupled to the input signal. You can set the input coupling to one of the options listed below.

DC

The input signal is coupled directly to the attenuator of the vertical control circuit. Set the input coupling to DC when you want to measure the entire signal, including both the DC and AC components.

AC (Only when measuring AC voltage)

The input signal is coupled to the attenuator of the vertical control circuit through a capacitor. Set the input coupling to AC when you want to measure only the amplitude of the AC signal without the DC component.

GND

The input signal is coupled to the ground rather than to the attenuator of the vertical control circuit. Set the input coupling to GND to check the ground level on the screen.

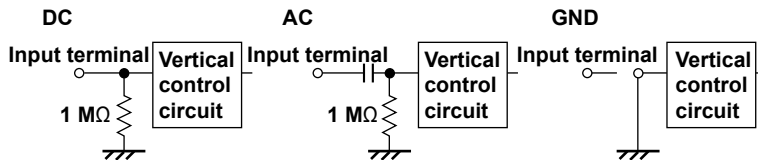

TC (Only when measuring temperature)

Set the coupling to TC when you are measuring temperature using the 701261 (UNIVERSAL), 701262 (UNIVERSAL (AAF)), 701265 (TEMP/HPV), 720266 (TEMP/HPV), or 720221 (16CH TEMP/VOLT).

DC-RMS

With the 720268 (HV (AAF, RMS)), the DC and AC components of the input signal are converted to RMS values and displayed. An RMS conversion circuit is connected to the same vertical-control-circuit coupling arrangement that is used when the input coupling is set to DC.

▶ [See here.](#)

AC-RMS

With the 720268 (HV (AAF, RMS)), the AC components of the input signal are converted to RMS values and displayed without the DC component. An RMS conversion circuit is connected to the same vertical-control-circuit coupling arrangement that is used when the input coupling is set to AC.

▶ [See here.](#)

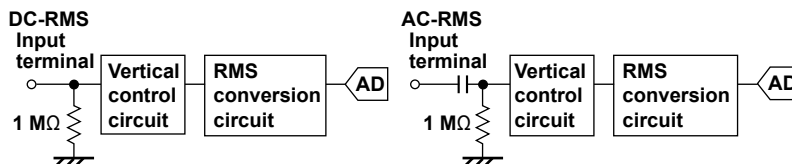

ACCEL (Only when measuring acceleration)

To measure acceleration with the 701275 (ACCL/VOLT), set the input coupling to ACCEL.

OFF (for the 16-CH Temperature/Voltage Input Module)

Set the coupling to OFF to not include in the measurement the sub channels selected on the 720221 (16CH TEMP/VOLT).

Probe Attenuation and Current-to-Voltage Conversion Ratio (Probe)

In voltage (current) measurements, a probe is used to connect the circuit under measurement to a signal input terminal. Using a probe has the following advantages.

- Prevents the disturbance of the voltage and current of the circuit being measured.
- Allows signals to be applied with no distortion.
- Expands the voltage (current) range that the instrument can measure.

When you use a probe, to read the measurement voltage (current) correctly, you must set the attenuation on the instrument to match the probe attenuation or current-to-voltage conversion ratio.

Set the attenuation ratio or current-to-voltage conversion ratio as indicated below for each probe. (The probes are optional accessories that are sold separately.)

Probe Type	Current-to-Voltage Conversion Ratio
10:1 safety probe (700929)	10:1
100:1 safety probe (701947)	100:1
Current probe (701933/701932)	10 A:1 V
Current probe (701930/701931)	100 A:1 V
Current probe (701917/701918)	1 A:1 V
Current probe (702915/702916)	10 A:1 V, 1 A:1 V
Clamp-on probe (720930)	100 A:1 V
Clamp-on probe (720931)	400 A:1 V
Differential probe (700924, 701926, 701977)	1000:1, 100:1
Differential probe (700925)	100:1, 10:1
10:1 passive probe (701940)	10:1
10:1 safety probe (wide temperature range type) (702902)	10:1

If you use a probe other than one of the separately sold optional accessories provided by Yokogawa, set the attenuation ratio or current-to-voltage conversion ratio in accordance with that probe. This instrument has the following settings.

Voltage Probe's Attenuation Ratio

1:1, 10:1, 100:1, 1000:1

Current Probe's Current-to-Voltage Conversion Ratio

1 A:1 V to 50 kA:1 V (1-2-5 steps), 400 A:1 V

For example, the output voltage rate can be converted to 1 V/A when the current-to-voltage conversion ratio is 1 A:1 V, 0.5 V/A when the ratio is 2 A:1 V, and 0.2 V/A when the ratio is 5 A:1 V.



Use a probe that is appropriate for the input capacitance of the module that you are using it with. Otherwise, the capacity cannot be adjusted.

Bandwidth Limit (Bandwidth)

You can specify a bandwidth limit for each module. You can use bandwidth limits to observe input signal waveforms with their noise components removed.

Normal Bandwidth Limits

High frequency components can be eliminated from the input signal. The bandwidth limits vary as shown below depending on the input module.

Input Module	Bandwidth Limit
720256 (4CH10M16)	62.5 Hz, 125 Hz, 250 Hz, 500 Hz, 1 kHz, 2 kHz, 4 kHz, 8 kHz, 16 kHz, 32 kHz, 64 kHz, 128 kHz, 400 kHz, Auto, Full
701250 (HS10M12), 720250 (HS10M12), 701255 (NONISO_10M12)	500 Hz, 5 kHz, 50 kHz, 500 kHz, Full
701251 (HS1M16)	400 Hz, 4 kHz, 40 kHz, Full
720268 (HV (AAF, RMS))	400 Hz, 4 kHz, 40 kHz, Auto, Full
720212 (HS200M14)	10 kHz, 20 kHz, 40 kHz, 80 kHz, 160 kHz, 320 kHz, 640 kHz, 1.28 MHz, 2.56 MHz, 5 MHz, Full
720211 (HS100M12)	10 kHz, 20 kHz, 40 kHz, 80 kHz, 160 kHz, 320 kHz, 640 kHz, 1.28 MHz, 2 MHz, Full
701261 (UNIVERSAL), ¹ 701262 (UNIVERSAL (AAF)), ¹ 701265 (TEMP/HPV)	2 Hz, 8 Hz, 30 Hz, Full
720266 (TEMP/HPV)	Line filter: 15 Hz Digital filter: 0.1 Hz, 1 Hz, 8 Hz, Full
701270 (STRAIN_NDIS), 701271 (STRAIN_DSUB)	10 Hz, 100 Hz, 1 kHz, Full
701261 (UNIVERSAL) ² , 701262 (UNIVERSAL (AAF)), 701275 (ACCL/VOLT)	40 Hz, 400 Hz, 4 kHz, Auto, Full
701281 (FREQ) ³ , 720281 (FREQ) ³	100 Hz, 1 kHz, 10 kHz, 100 kHz, Full
720254 (4CH 1M16)	6.25 Hz, 12.5 Hz, 25 Hz, 50 Hz, 100 Hz, 200 Hz, 400 Hz, 800 Hz, 1.6 kHz, 3.2 kHz, 6.4 kHz, 12.8 kHz, 40 kHz, Full

- 1 When measuring temperature.
- 2 When measuring voltage. Auto cannot be selected on the 701261.
- 3 Full cannot be selected when Preset is set to AC100 V or AC200 V.

For example, 400 Hz, 4 kHz, and 40 kHz frequency bandwidth limits are available on the 701251 (HS1M16). The frequency characteristics for the different bandwidth limits are shown below. If you select Full, the input module's maximum bandwidth is used.

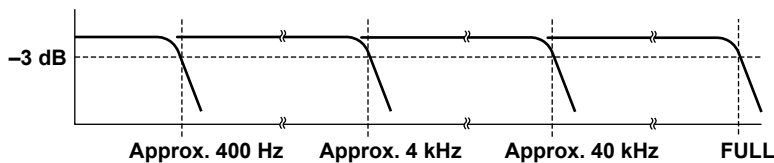

Bandwidth Limit of the 720256 (4CH10M16), 701262 (UNIVERSAL (AAF)), 701275 (ACCL/VOLT), 720268 (HV (AAF, RMS))

When you are measuring voltage using the 701262 (UNIVERSAL (AAF)) or when you are using the 720256 (4CH10M16), 701275 (ACCL/VOLT), or 720268 (HV (AAF, RMS)) and the bandwidth is set to Auto, the anti-aliasing and low-pass filter settings vary as shown below depending on the sample rate of each channel.

720256			701262/701275		
Sample Rate	Anti-Aliasing Filter	Low-pass Filter	Sample Rate	Anti-Aliasing Filter	Low-pass Filter
10 MS/s	200 kHz	400 kHz	100 kS/s	40 kHz	OFF
5 MS/s	200 kHz	400 kHz	50 kS/s	20 kHz	OFF
2 MS/s	200 kHz	400 kHz	20 kS/s	8 kHz	OFF
1 MS/s	200 kHz	400 kHz	10 kS/s	4 kHz	4 kHz
500 kS/s	200 kHz	400 kHz	5 kS/s	2 kHz	4 kHz
200 kS/s	80 kHz	400 kHz	2 kS/s	800 Hz	4 kHz
100 kS/s	40 kHz	400 kHz	1 kS/s	400 Hz	400 Hz
50 kS/s	20 kHz	400 kHz	500 S/s	200 Hz	400 Hz
20 kS/s	8 kHz	400 kHz	200 S/s	80 Hz	400 Hz
10 kS/s	4 kHz	400 kHz	100 S/s	40 Hz	40 Hz
5 kS/s	2 kHz	400 kHz	50 S/s	20 Hz	40 Hz
2 kS/s	800 Hz	400 kHz	20 S/s to 5 S/s	20 Hz	40 Hz
1 kS/s	400 Hz	400 kHz	2 S/s or less	20 Hz	40 Hz
500 S/s	200 Hz	400 kHz	Ext sample	40 kHz	OFF
200 S/s	80 Hz	400 kHz			
100 S/s	40 Hz	400 kHz			
50 S/s or less	40 Hz	400 kHz			
Ext sample	OFF	OFF			

720268		
Sample Rate	Anti-Aliasing Filter	Low-pass Filter
1 MS/s	40 kHz	40 kHz
500 kS/s	40 kHz	40 kHz
200 kS/s	40 kHz	40 kHz
100 kS/s	40 kHz	40 kHz
50 kS/s	20 kHz	40 kHz
20 kS/s	8 kHz	40 kHz
10 kS/s	4 kHz	4 kHz
5 kS/s	2 kHz	4 kHz
2 kS/s	800 Hz	4 kHz
1 kS/s	400 Hz	400 Hz
500 S/s	200 Hz	400 Hz
200 S/s	80 Hz	400 Hz
100 S/s	40 Hz	400 Hz
50 S/s or less	40 Hz	400 Hz
Ext sample	OFF	OFF

For example, when the sample rate is between 500 kS/s and 100 S/s, the cutoff frequency of the anti-aliasing filter is 40 % of the sample rate.

Bandwidth Limit on the 720221 (16CH TEMP/VOLT)

The bandwidth limits vary depending on the set data update period.

Data update interval	Bandwidth Limit	Data update interval	Bandwidth Limit
100 ms	600 Hz	1 s	50 Hz
300 ms	200 Hz	3 s	10 Hz

Digital Filter (Filter)

You can select the digital filter on models with the /G03 or /G05 option.

▶ [See here.](#)

Assignments to Display Groups (Display)

Set whether to assign the target trace to display groups 1 to 4.

- ON: The trace is assigned to a display group.
- OFF: The trace is excluded from the display group.

You can also make assignments using the display group settings in the DISPLAY menu.

▶ See here.

Zoom Method (V Scale)

This is a setting available in Scope mode. You can choose the method for zooming the waveform vertically.

- DIV: The waveform is zoomed by a set magnification. Set the following items.
 - [Waveform Vertical Position \(Vertical POSITION knob\)](#)
 - [Magnification for Zooming \(V Zoom\) and Offset \(V Zoom/Offset\)](#)
- SPAN: The waveform is zoomed to fit within specified [upper and lower display limits](#).

In Recorder mode, V Scale is set with SPAN.



When the vertical position, offset, or upper or lower limit is changed, data falling outside the measurement range is handled as overflow data. Overflow data will appear as a clipped waveform as shown below.

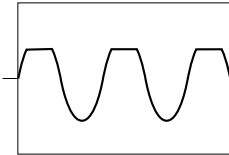

Waveform Vertical Position (Vertical POSITION knob)

This is a setting available in Scope mode.

If V Scale is set to DIV, set the waveform vertical position. The instrument can display the waveforms of the main analog-input channels, the waveforms of the sub analog-input channels, and computed waveforms. Because the instrument can display so many waveforms, the waveforms may overlap and be difficult to view. If this happens, you can adjust the vertical display position to make waveforms easier to view (vertical position).

The vertical position can be moved within the range of ± 5 div.

The vertical scale (V/div) changes with the vertical position mark at the center.

Set the vertical position using the POSITION knob for each main and sub channel. ▶ See here.

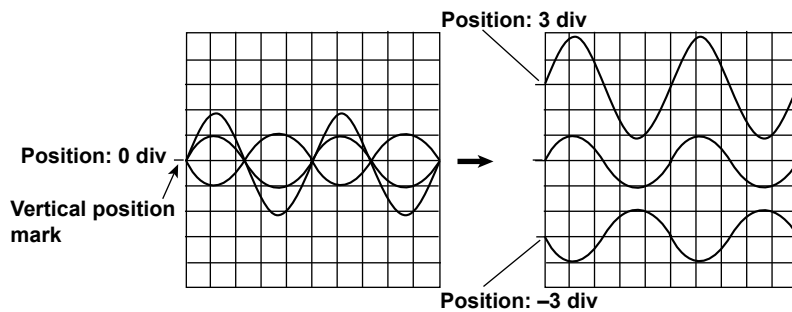

- You cannot use the vertical position setting to move the vertical position of a temperature, strain, or computed waveform.
- When the all channel setup (ALL CH) or all sub channel setup (ALL Sub Channels Setup) menu is displayed, you can change the vertical position using the settings in the setup dialog box.

Magnification for Zooming (V Zoom) and Offset (V Zoom/Offset)

You can specify the following items.

- [Vertical Zoom \(V Zoom\)](#)
- [Offset \(Offset\)](#)

Vertical Zoom (V Zoom)

This is a setting available in Scope mode. When V Scale is set to DIV, you can set the vertical magnification and enlarge or reduce the waveform along the vertical axis. This method is useful when you want to change the vertical scale of the waveform after it has been displayed.

Zoom Factor (V Zoom)

The zoom factors that you can choose from are listed below.

x0.1, x0.111, x0.125, x0.143, x0.167, x0.2, x0.25, x0.33, x0.4, x0.5, x0.556, x0.625, x0.667, x0.714, x0.8, x0.833, x1, x1.11, x1.25, x1.33, x1.43, x1.67, x2, x2.22, x2.5, x3.33, x4, x5, x6.67, x8, x10, x12.5, x16.7, x20, x25, x40, x50, x100

The range of zoom factors that you can choose varies under special circumstances as described below.

When measuring acceleration using the 701275 (ACCL/VOLT)

x0.5 to x50

701281 (FREQ) and 720281 (FREQ)

x0.33 to x100

When using the 720230 (LOGIC)

x0.1 to x3.33

Zoom Position

Zooming is centered on the vertical position.

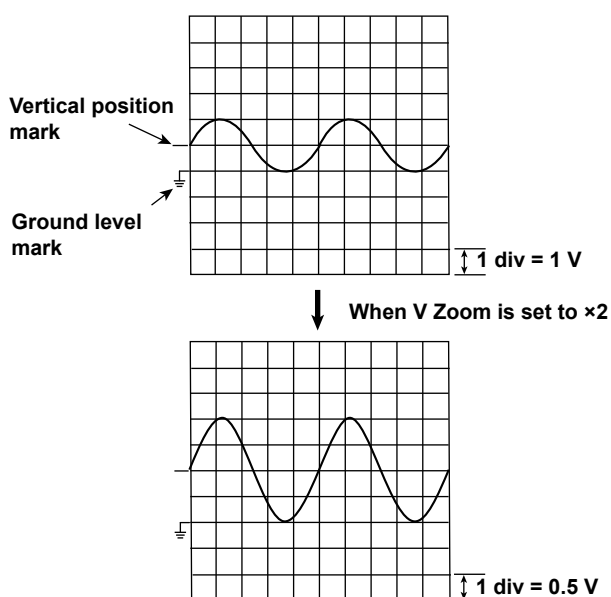

2 Channel Setup

Offset (Offset)

This is a setting available in Scope mode. When you set V Scale to DIV, you can add an offset to move the waveform to an easy-to-view vertical position. For example, when measuring a signal riding on a given voltage, you can cancel the given voltage with an offset to measure only the changes in the signal at a higher voltage sensitivity.

The offset setting is valid when measuring voltages or measuring frequencies or other parameters or on a frequency module.

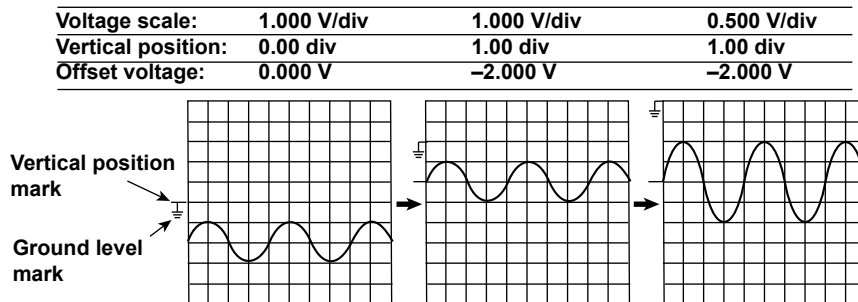

Selectable Offset Range

When measuring voltages: ± 5 div

On a frequency module, the range varies depending on what is being measured.

- When measuring frequencies: $\pm(\text{Value/div}) \times 1000$ or 500 kHz
- When measuring revolutions in rpm: $\pm(\text{Value/div}) \times 1000$ or 50 krpm
- When measuring revolutions in rps: $\pm(\text{Value/div}) \times 1000$ or 1000 rps
- When measuring periods: $\pm(\text{Value/div}) \times 1000$ or 50 s
- When measuring duty cycles: $\pm(\text{Value/div}) \times 1000$ or 100 %
- When measuring pulse widths: $\pm(\text{Value/div}) \times 1000$ or 50 s
- When measuring pulse integration: $\pm(\text{Value/div}) \times 1000$ or $1.0000\text{E}+22$
- When measuring velocity: $\pm(\text{Value/div}) \times 1000$ or $1.0000\text{E}+22$

Notes about Setting the Offset

- When measuring voltages, the changed offset is valid even when acquisition is stopped. When measuring frequencies and other parameters on a frequency module, changes to the offset is invalid when acquisition is stopped. The changed offset will be applied to the next measurement.
- When measuring voltages, if you change the probe attenuation, the vertical scale settings change the voltages that have been scaled with the new attenuation ratio.
- When measuring voltages, changing the voltage scale does not change the offset. However, if the offset value goes outside the selectable range, the offset is set to the maximum or minimum value in the voltage scale range. If you do not change the offset and set the voltage scale back to its original value, the offset returns to its original value.



- The offset does not affect cursor-measurement values, automated measurement values of waveform parameters, or computed values.
- You can change the position of the waveform relative to the vertical position (change the focus of the vertical zoom) by changing the offset.

Zooming by Setting Upper and Lower Display Limits (Upper/Lower)

In Recorder mode or when V Scale is set to SPAN in Scope mode, you can set the upper and lower vertical limits and enlarge or reduce the waveform along the vertical axis. By setting the appropriate upper and lower limits for the displayed waveform, you can zoom in vertically on the area of the waveform that you want to observe. You can also increase the display range to view parts of the waveform that were outside the range. Zooming the waveform does not change its A/D conversion resolution or accuracy.

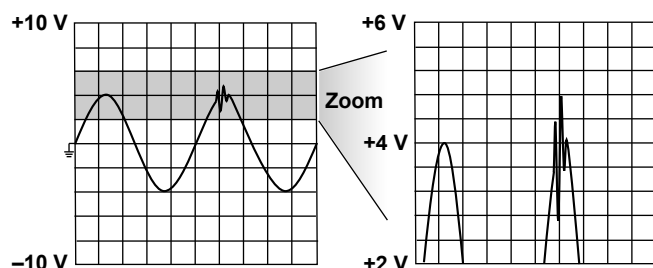

Selectable Range of the Upper and Lower Limits

The upper and lower limits can be set within $\pm(100 \times \text{the specified V/div value})$ or $\pm 2000 \text{ V}$, whichever is lower. Set the limits so that the upper limit is greater than the lower limit.

- The range of the upper and lower limits for the 701270 (STRAIN_NDIS) and 701271 (STRAIN_DSUB) varies as indicated below depending on the range unit.
 - When the range unit is μSTR : $\pm 30000 \mu\text{STR}$
 - When the range unit is mV/V : $\pm 15 \text{ mV/V}$
- For the 701275 (ACCL/VOLT), the range of the upper and lower limits is $\pm 2000000 \text{ m/s}^2$.
- For the 701281 (FREQ) or 720281 (FREQ), the range of the upper and lower limits is $(\text{offset}) \pm (\text{Value/div} \times 30)$. However, depending on the type of signal being measured, the maximum range is as follows:
 - When measuring frequencies: -1500 kHz to 1500 kHz
 - When measuring revolutions in rpm: -300 krpm to 300 krpm
 - When measuring revolutions in rps: -6000 rps to 6000 rps
 - When measuring periods: -150 s to 150 s
 - When measuring duty cycles: -600% to 600%
 - When measuring pulse widths: -150 s to 150 s
 - When measuring pulse integration: $-1.5\text{E}+21$ to $1.5\text{E}+21$
 - When measuring velocity: $-1.5\text{E}+21$ to $1.5\text{E}+21$

Upper and Lower Limit Linking

If you select both upper and lower limits to be changed, you can change the upper and lower limits while keeping the interval between them constant.



If you change vertical scale after setting the upper and lower limits, the waveform display range will not change, but the measurable range will change. If you change the measurable range so that it is narrower than the range of the set upper and lower limits, when you start waveform acquisition, the parts of the waveform that do not fit within the measurable range may not appear. Since the measurement range is $0 \text{ V} \pm 10 \text{ div}$ (the absolute width, or span, is 20 div), the measurable range is approximately ± 10 times the vertical scale (V/div) (20 times in terms of span) in Scope mode and approximately ± 1 time the vertical scale (Full Range) (twice in terms of span).

Input Signal Adjustment (Adjustment)

You can specify the following items.

- [DC Offset Cancellation \(DC Offset Cancel\)](#)
- [Gain Adjustment \(Gain Adjustment\)](#)
- [Deskewing \(Skew Adjustment\)](#)

DC Offset Cancellation (DC Offset Cancel)

This function can be used to determine cursor measurement values, automatically measured values of waveform parameters, and computed values by assuming the DC signal voltage measured during offset adjustment to be 0 V. The adjustment range is $\pm 30\%$ of the measurement range. For example, in Scope mode, if the vertical scale is set to 1 V/div, up to 3 V can be assumed to be 0 V. Note that when the offset is adjusted, the measurable range changes. In addition, if you change the measurement range during offset adjustment, the offset is measured when the range is changed, and this new offset is used to determine the values. However, if you change the vertical scale and the measured value falls outside $\pm 30\%$ of the measurement range, correct measurement will no longer be possible. For example, if you are measuring a 5 V DC signal with the vertical scale set to 2 V/div, adjustment is possible because the signal corresponds to 25 % the measurement range. But, if you change the vertical scale to 1 V/div, the signal corresponds to 50 % the measurement range, and therefore adjustment is not possible. If DC offset canceling is enabled, the target channel label is highlighted.

- **ON**
DC offset canceling is enabled.
- **OFF**
DC offset canceling is disabled.
- **Execute (Execute)**
Executes offset adjustment.

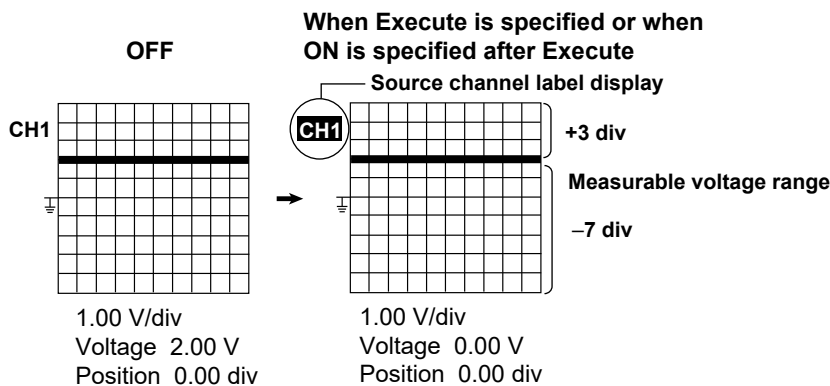

- The settings (ON state and the value adjusted with Execute) are not retained when the instrument is turned off. If necessary, save the waveform data and setup data.
- This function can be used on voltage measurement modules 720256 (4CH10M16), 701250 (HS10M12), 720250 (HS10M12), 701251 (HS1M16), 701255 (NONISO_10M12), 720212 (HS200M14), 720211 (HS100M12), and 720254 (4CH 1M16).

Gain Adjustment (Gain Adjustment)

Gain adjustment is used to adjust measured voltages. The adjustment range is $\pm 5\%$. The setting resolution is down to the fourth decimal place on all modules that can use this function.



- The setting is retained even when the instrument is turned off.
- This function can be used on voltage measurement modules 720256 (4CH10M16), 701250 (HS10M12), 720250 (HS10M12), 701251 (HS1M16), 701255 (NONISO_10M12), 720212 (HS200M14), 720211 (HS100M12), and 720254 (4CH 1M16).
- The gain adjustment is reset to 1.0000 when Execute or ON is specified for DC offset adjustment.
- Gain adjustment is not possible when DC offset cancellation is set to ON.

Deskewing (Skew Adjustment)

The signal time offset (skew) between channels can be corrected.

You can do this on the 720212, 720211, 720256, 701250, 720250, 701255 and 720230 (modules with a 10 MS/s or higher maximum sample rate) and the 720230 logic input module.

Selectable range: -1.0 us to 1.0 us

Resolution: 0.1 us (on 10 MS/s modules), 0.01 us (on 100 MS/s or 200 MS/s modules)

Inverted Waveform Display (Invert)

When measuring voltage and strain, you can invert the waveform display around the vertical position.

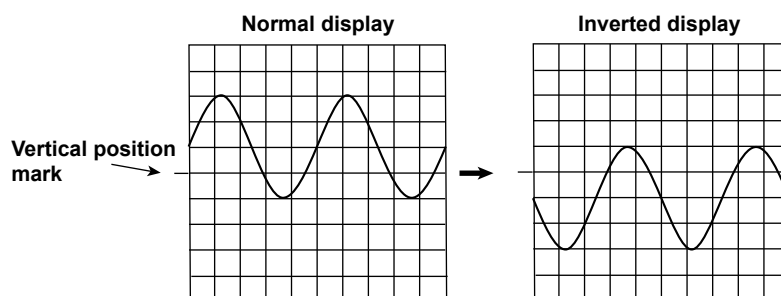

- Cursor measurements, automated measurements of waveform parameters, and computations are performed on the inverted waveforms.
- Even when inverted waveforms are displayed, triggering is based on the uninverted waveforms.
- When measuring strain, you cannot invert waveforms whose measurement has finished. The inversion setting will be applied when the next measurement starts.

Sample Rate (Sample Rate), Sample Interval (Sample Interval)

You can change the sample rate (in Scope mode) or sample interval (in Recorder mode) for each channel.

Scope Mode

- The set record length that you set on the ACQUIRE menu and the time scale (TIME/DIV) do not change even if you change the channel setting's sample rate.
- When you decrease the sample rate in the channel settings, the sampled data is decimated, so the number of waveform data points is reduced. This is useful when you want to reduce the waveform data file size.
- On modules whose maximum sample rate is 1 MS/s or less,* the channel setting's sample rate can be set as fast as 10 MS/s (only when a 10 MS/s or faster module is installed). However, it is not possible to set a sample rate faster than that determined by the set record length and time scale. Furthermore, the data is interpolated using the previous sample data, so all the data will be the same during the data update period.
- When dual capture is enabled, the low-speed and high-speed sample rates can be changed.

Recorder Mode

- Changing the sample interval in the channel settings does not change the sample interval set in the ACQUIRE menu.
- When you increase the sample interval in the channel settings, the sampled data is decimated, so the number of waveform data points is reduced. This is useful when you want to reduce the waveform data file size.
- On modules whose maximum sample rate is 1 MS/s or less,* the channel setting's sample interval can be set as short as 100 ns (10 MS/s) (only when a 10 MS/s or faster module is installed). However, the sample interval cannot be set shorter than the sample interval set on the ACQUIRE menu. Furthermore, the data is interpolated using the previous sample data, so all the data will be the same during the data update period.

* On the 16-CH temperature/voltage input module (720221), the sample period cannot be set faster than the sample rate or sample interval determined by the data update interval setting.

Linear Scaling (Linear Scale)

Linear scaling is a function that converts measured values into physical values and reads them directly. When you measure voltage (current), strain, or frequency (revolutions, periods, duty cycles, power supply frequencies, pulse widths, pulse integration, velocities), you can choose from one of two linear scaling methods: $AX + B$ or $P1-P2$.

Linear Scaling Modes (Scaling Mode)

- **OFF**

Linear scaling is not performed.

- **AX+B**

Using the specified scaling coefficient A and offset B, the instrument performs the following computation to scale cursor-measurement values and automated measurement values of waveform parameters. You can specify the unit of the linearly scaled results.

$$Y=AX+B$$

X: Value before scaling

Y: Value after scaling

Selectable range for A and B: $-9.9999E+30$ to $+9.9999E+30$

However, coefficient A cannot be set to zero.

Default A value: $+25.000E+00$

Default B value: $-25.000E+00$

- **P1-P2**

You can specify two measured values ($P1[X]$, $P2[X]$) and specify a scale value ($P1[Y]$, $P2[Y]$) for each. The scale-conversion equation ($y = ax + b$) is determined by these four values.

- Measured value ($P1[X]$, $P2[X]$) range: Same as the measurement range

- Scale value ($P1[Y]$, $P2[Y]$) range: $-9.9999E+30$ to $+9.9999E+30$

However, you cannot set measured or scaled values $P1$ and $P2$ that would make value a in the scaling equation zero or an incalculable value.

- Default scale values

$P1[X]:+1.0000E+00$, $P1[Y]:+0.0000E+00$

$P2[X]:+5.0000E+00$, $P2[Y]:+100.00E+00$

- Get Value (Get Value)

Sets $P1[X]$ and $P2[X]$ to the current values (the values displayed by the level indicator), regardless of whether waveform acquisition is in progress.

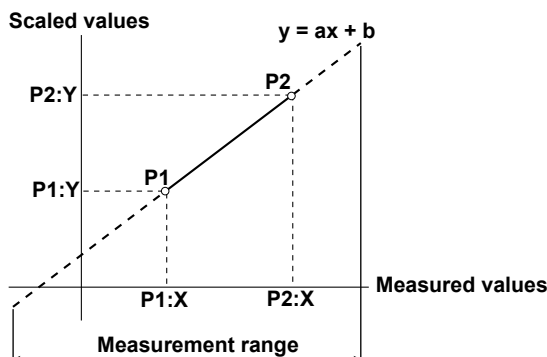

Unit (Unit)

You can set the unit using up to four alphanumeric characters.

Display Type (Display Type)

When you measure voltage using a voltage module or measure strain using a strain module, you can display the linearly scaled results using one of the following two methods.

Exponent (Exponent): Values are displayed in exponential notation.

Floating (Floating): Values are displayed as decimal numbers.

For Decimal Number, set the number of decimal places to Auto or a number from 0 to 3. For SubUnit, set the unit prefix to Auto, p, n, μ , m, None, k, M, G, or T.

- If you set Decimal Number to a number from 0 to 3, the specified number of decimal places are displayed. If you select Auto, all numbers will be displayed using five digits (for example: 1.0000, 250.00). The default setting is Auto.
- If you set SubUnit to a setting other than Auto, numbers will be displayed with the specified unit prefix. If you select Auto, the instrument will automatically select appropriate unit prefixes. The default setting is Auto. The instrument displays values in exponential notation if it is unable to display them as decimal numbers.

Scale Value Display (Scale Display)

You can display the linearly scaled values of the upper and lower vertical limits of each channel.

You can turn the scale value display on and off using the detail setup (Detail Setup) on the Display menu.

▶ [See here.](#)



-
- Linear scaling cannot be performed for measurements of temperature or acceleration.
 - The following waveforms cannot be linearly scaled.
Accumulated waveforms (except for the most recent)
 - You can configure linear scaling for each channel.
 - The specified scaling coefficient A and offset B are retained even after linear scaling is set to OFF.
 - Computations are performed on the linearly scaled values.
-

RMS Measurement

If a 720268 (HV (AAF, RMS)) channel is selected, you can observe the RMS values (RMS) of the input signal if the **input coupling (Coupling)** is set to AC-RMS or DC-RMS.

AC-RMS

Use this setting when you only want to observe the RMS values of the input signal without the DC component.

Example

When you measure the RMS values of a 2 V_{peak} sine wave, an approximately 1.4 VDC signal appears, as shown in the figure on the right.

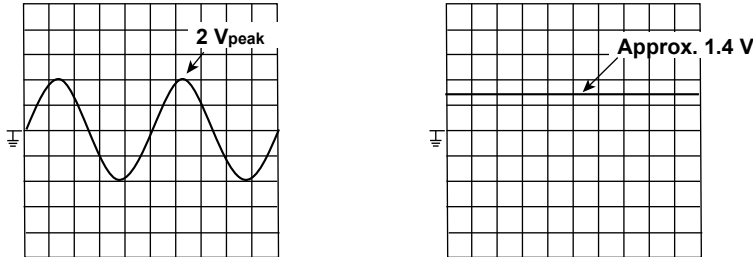

RMS values are calculated using the following equation.

$$\sqrt{\frac{1}{T} \int_0^T u(t)^2 dt} \quad u(t): \text{Input signal, } T: \text{One cycle of the input signal}$$

Given $u(t) = V_m \sin \omega t$ (where V_m is the peak value and ω is the angular velocity of $2\pi f$, with f being the frequency of the sine wave signal), the RMS value V_{rms} is:

$$V_{rms} = \sqrt{\text{Average of } u(t)^2 \text{ over one cycle}} = \sqrt{\frac{1}{2\pi} \int_0^{2\pi} (V_m \sin \omega t)^2 d\omega t} = \frac{V_m}{\sqrt{2}}$$

As shown in the example above, if V_m is 2 V, the RMS value V_{rms} is approximately 1.4 V.

DC-RMS

Use this setting when you want to observe the RMS values of the entire signal, including both the DC and AC components.

Example

When you measure the RMS values of a 2 V_{peak} sine wave with a 1 VDC component superimposed on it, an approximately 1.7 VDC signal appears, as shown in the figure on the right.

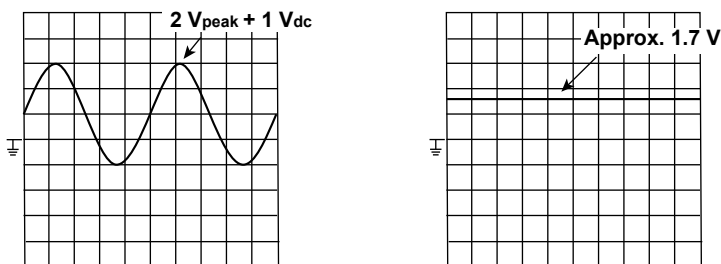

Given DC component V_{dc} and AC component $u(t) = V_m \sin \omega t$, the RMS value $V_{rms (+DC)}$ of a sine wave signal with a DC component superimposed on it is:

$$V_{rms(+DC)} = \sqrt{\frac{1}{2\pi} \int_0^{2\pi} (V_m \sin \omega t + V_{dc})^2 d\omega t} = \sqrt{\left(\frac{V_m}{\sqrt{2}}\right)^2 + (V_{dc})^2}$$

As shown in the example above, if V_{dc} is 1 V and V_m is 2 V, the RMS value $V_{rms (+DC)}$ is approximately 1.7 V.



In RMS measurement mode, when a signal with an AC component below 40 Hz is acquired, because of the characteristics of the RMS circuit, a ripple component is displayed, and the RMS values are not displayed properly. DC signals are measured properly.

Temperature Measurement

For temperature measurement, the items that have to be set for each input signal (CH1 to CH16) include input coupling, thermocouple type, bandwidth limit, trace settings, temperature settings, and temperature unit.

You can connect a thermocouple to one of the temperature modules, 701261 (UNIVERSAL), 701262 (UNIVERSAL (AAF)), 701265 (TEMP/HPV), or 720266 (TEMP/HPV), and measure temperatures.

For information about how to connect thermocouples, see section 3.9 in the *Getting Started Guide*, IM DL950-03EN.

Waveform Input ON/OFF (Input)

You can set whether to acquire input signal waveforms for each channel.

- ON: Waveforms are acquired.
- OFF: Waveforms are not acquired.

Label (Label)

▶ [See here.](#)

Input Coupling (Coupling)

Set the coupling to TC when you are measuring temperature using the 701261 (UNIVERSAL), 701262 (UNIVERSAL (AAF)), 701265 (TEMP/HPV), or 720266 (TEMP/HPV).

To measure voltage, set the input coupling to an appropriate voltage measurement setting.

▶ [See here.](#)

Thermocouple Type (TC Type)

Select the type according to the thermocouple you want to use.

Select the thermocouple type from below.

If the input terminal is open, the displayed value is set to a value less than or equal to the lower limit of the measuring range.

Type	Measurement Range
K	-200 to 1300 °C
E	-200 to 800 °C
J	-200 to 1100 °C
T	-200 to 400 °C
L	-200 to 900 °C
U	-200 to 400 °C
R	0 to 1700 °C
S	0 to 1700 °C
B	400 to 1800 °C
N	0 to 1300 °C
W	0 to 2300 °C
Au7Fe (AuFe-chromel)	0 to 300 K

Bandwidth Limit (Bandwidth)

Select the bandwidth from below.

- 701261, 701262, 701265: 2 Hz, 8 Hz, 30 Hz, Full
- 720266: 0.1 Hz, 1 Hz, 8 Hz, Full

▶ [See here.](#)

Assignments to Display Groups (Display)

▶ [See here.](#)

Display Range (Upper/Lower)

To display the measured waveform on the screen, you need to set upper and lower display range limits that are appropriate for the input.

Selectable range:

- -5432 to 5432 °C (when the resolution is 0.1 °C)
- -5432 to 5432 K (when the resolution is 0.1 K)

The minimum span is 2 °C (or 2 K).

Upper and Lower Limit Linking

If you select both upper and lower limits to be changed, you can change the upper and lower limits while keeping the interval between them constant.

Temperature Unit (Unit)

Set the temperature unit to °C or K. The default setting is °C.

Reference Junction Compensation and Burnout (Temperature Setup)

Reference Junction Compensation (RJC)

The voltage produced by thermocouple is based on the temperature of the point that you are measuring and the temperature of the reference junction. Reference junction compensation (RJC) refers to the act of correcting for the temperature of the measuring instrument and using it as a cold junction.

On the instrument, you can turn the internal RJC circuit on and off.

- ON: Select ON to use the RJC circuit to perform reference junction compensation.
There is an RJC circuit inside the 701261, 701262, 701265, and 720266 temperature modules and also inside the 701953 scanner box that is connected to a 720221 16-CH temperature/voltage input module.
- OFF: Select OFF to check measured temperature values or use an external reference junction (0 °C).

Normally, you should perform measurements with RJC set to ON.



When you set RJC to OFF and apply a voltage that corresponds to a temperature t to an input terminal, if the measured temperature does not match temperature t , the instrument or the module may be damaged. Contact your nearest YOKOGAWA dealer.

Burnout (Burn Out)

Specify how the instrument is to behave when the thermocouple input detects a burnout.

- ON: When a burnout is detected, the measured value is fixed at the upper limit (Upper) of the measurement range of thermocouple.
- OFF: Burnouts are not detected.

The default setting is OFF.

Sample Rate (Sample Rate), Sample Interval (Sample Interval)

▶ [See here.](#)

Temperature Measurement (For the 16-CH Temperature/Voltage Input Module)

The 720221 16-CH temperature/voltage input module can perform temperature or voltage measurements on 16 channels. When the input coupling is set to TC, temperature measurements are performed on 16 channels. When the input coupling is set to DC, voltage measurements are performed on 16 channels.

When the input coupling is set to TC, configure settings such as the thermocouple type, display range, temperature unit, trace, reference junction compensation, and burnout.

When the input coupling is set to DC, the items that you have to set for each input signal (sub channel 1 to sub channel 16) include vertical scales, vertical positions, input coupling, bandwidth limit, zoom method, offset, waveform inversion, trace settings, and linear scaling.

For the 720221 16-CH Temperature/Voltage Input Module, the bandwidth limit is set depending on the data update period, so no bandwidth limit setting is displayed.

Scanner Box (built-in reference junction)

Connect the 720221 16-CH temperature/voltage input module to a scanner box with a cable to measure temperature or voltage. You can connect up to 16 thermocouples or wires to a 701953 scanner box. For the connection procedure, see section 3.14 in the *Getting Started Guide* (IM DL950-03EN).

Waveform Input ON/OFF (Input)

You can set whether to acquire input signal waveforms for each module. You can turn the display of each main channel (CH1, CH3, CH5, CH7, CH9, CH11, CH13, and CH15) on and off.

- ON: Waveforms are acquired.
- OFF: Waveforms are not acquired.



- The 16-CH temperature/voltage input module uses only the odd main channels of the slot that it is inserted into. It cannot use the slot's even main channels.
- On the 16-CH temperature/voltage input module, turning off the waveform input turns off the acquisition of all the module's sub channels. To turn off the waveform acquisition of individual sub channels, turn off their input coupling.

Data Update Period (Data update period)

The displayed or saved waveform data is updated at the specified period. The [bandwidth limit](#) varies depending on the data update period.

Data update interval	Bandwidth Limit
100 ms	600 Hz
300 ms	200 Hz
1 s	50 Hz
3 s	10 Hz

All Sub Channel Setup (All SubChannels Setup)

You can configure the settings of all sub channels while viewing the settings in a list. You can also copy the various vertical axis settings of one sub channel to other sub channels. There are some items that cannot be configured from the All Sub Channels Setup list.

Input Setup (Setup)

- **When the Input Coupling Is Set to DC, GND, or OFF**

You can set the following: display color, label (Label), coupling (Coupling), vertical scale (V/Div, Full Range), zoom method (V Scale), offset (Offset), position (Position), magnification for zooming (V Zoom), display range limits for zooming (Upper/Lower).

The settings are the same as those of each sub channel. ► [See here.](#)

- **When the Input Coupling Is Set to TC**

You can set the following: display color, label (Label), coupling (Coupling), thermocouple type (Type), temperature unit (Unit), display range settings (Upper/Lower), reference junction compensation (RJC), burnout (Burn Out).

The settings are the same as those of each sub channel. ► [See here.](#)

Linear Scaling (Linear Scale)

You can configure the linear scaling settings of all sub channels while viewing the settings in a list. You cannot configure these settings when the input coupling is set to TC.

You can set the following: linear scaling (Linear Scale), AX+B:A P1-P2 P1:X, AX+B:B P1-P2 P1:Y, P1-P2 P2:X, P1-P2 P2:Y, unit string (Unit), display mode (Disp Type), number of decimal places (Decim Num), unit prefix (Sub Unit).

The settings are the same as those of each sub channel. ► [See here.](#)

Copy (Copy to)

You can copy the vertical and linear scaling settings of one sub channel to other sub channels.

- **Copy Source Sub Channel (Source Sub Channel)**

Select the copy source sub channel from 1 to 16.

- **Copy Destination Sub Channel (Destination Sub Channel)**

Select the copy destination sub channel from below.

All ON (ALL ON), All OFF (ALL OFF), 1 to 16

- **Execute (Execute)**

Select Execute to copy the settings.



The waveform display color and label settings are not copied.

Sub Channels 1 to 16 (Sub Channel 1 to 16)

The sub channel menu that corresponds to the key you pressed appears. You can set the various vertical axis settings for each sub channel.

Vertical Scale (SCALE knob)

▶ [See here.](#)

Input Coupling (Coupling)

You can set the input coupling to DC, TC, GND, or OFF. Sub channels whose coupling is set to OFF are not measured or displayed.

▶ [See here.](#)

The setup menu varies depending on the input coupling that you select.

When the Input Coupling Is Set to DC, GND, or OFF

- **Zoom Method (V Scale)**
▶ [See here.](#)
- **Waveform Vertical Position (Vertical POSITION knob)**
▶ [See here.](#)
- **Zooming by Setting a Magnification (V Zoom)**
▶ [See here.](#)
- **Offset (Offset)**
▶ [See here.](#)
- **Zooming by Setting Upper and Lower Display Limits (Upper/Lower)**
▶ [See here.](#)
- **Inverted Waveform Display (Invert)**
▶ [See here.](#)
- **Assignments to Display Groups (Display)**
▶ [See here.](#)
- **Linear Scaling (Linear Scale)**
▶ [See here.](#)

When the Input Coupling Is Set to TC

- **Thermocouple Type (TC Type)**
▶ [See here.](#)
- **Display Range (Upper/Lower)**
▶ [See here.](#)
- **Reference Junction Compensation and Burnout (Temperature Setup)**
▶ [See here.](#)
Built-in reference junction in scanner box.
- **Assignments to Display Groups (Display)**
▶ [See here.](#)
- **Temperature Unit (Unit)**
▶ [See here.](#)

Notes about Using the 16-CH Temperature/Voltage Input Module (720221)

In comparison with normal temperature modules, which can receive input from two thermocouples, the 16-CH Temperature/Voltage Input Module has sub channels that enable it to receive input from 16 thermocouples through a scanner box. You can also measure the voltage of 16 channels. The 16-CH Temperature/Voltage Input Module samples the measured sub channels in order.

Main channel sample rate: 200 kS/s

Sub channel sample rate: 10 kS/s

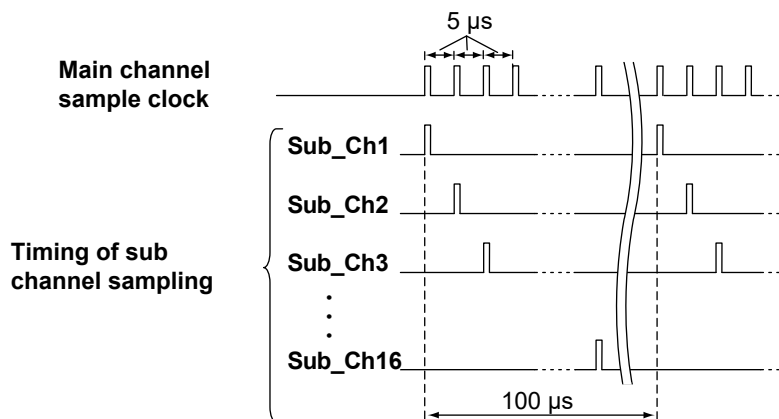

- The 16-CH temperature/voltage input module uses only the odd main channels of the slot that it is inserted into. It cannot use the slot's even main channels.
- If you do not want to measure an individual sub channel, turn its input coupling off. Sampled data is not acquired for sub channels whose input coupling is turned off.
- Regardless of the number of measured sub channels, the actual maximum sample rate is 100 kS/s. The rate at which data is written to the acquisition memory varies depending on the main channel sample rate. For details on the rate at which data is written to the acquisition memory, see appendix 3 in the *Getting Started Guide*, IM DL950-03EN.
- The sample rate that is displayed on the screen is the sample rate of the main channel.
- The record length of each sub channel is less than or equal to the set record length/16.
- The timing of waveform acquisition is different for each sub channel, but all the sub channels are stored in the acquisition memory as if they had been sampled at the same timing. This means that the sampling times of the acquired waveform data are different from the sampling times of the actual applied waveforms.
- Because the waveform data stored in the acquisition memory is used to display waveforms on the screen, the data of all sub channels is displayed as if though it were sampled at the same timing.
- The waveforms displayed on the screen are updated at the set [data update period](#) regardless of the number of measured sub channels. The previous value is stored repeatedly in acquisition memory until the value changes. Saved waveform data is treated in the same manner.
- The following operations are performed on the waveform data stored in the acquisition memory: waveform zooming, cursor measurement, the automated measurement of waveform parameters, computation, FFT, waveform searches, and the loading and saving of waveform data.
- GO/NO-GO determination and the display and searching of history waveforms are not performed on sub channels.
- When you execute auto setup on the 16-CH Temperature/Voltage Input Module, sub channel on/off settings and horizontal axis (TIME/DIV) settings are not changed.
- Connect the 16-CH temperature/voltage input module to the scanner box with a cable and then connect a thermocouple to the scanner box to perform temperature measurements. For information about how to connect thermocouples to the scanner box's terminal block, see section 3.14 in the *Getting Started Guide*, IM DL950-03EN.

Strain Measurement

For strain measurement, the items that have to be set for each input signal (CH1 to CH16) include vertical scales, sensor settings, the bandwidth limit, the display range, the range unit, trace settings, waveform inversion, and linear scaling.

To measure strain, connect a strain measurement bridge (bridgehead) or a strain gauge transducer to the 701270 (STRAIN_NDIS) or 701271 (STRAIN_DSUB) strain module.

For information about how to connect a bridgehead, see section 3.10 in the *Getting Started Guide*, IM DL950-03EN.

- [Waveform Input ON/OFF \(Input\)](#)
- [Label \(Label\)](#)
- [Vertical Scale \(SCALE knob\)](#)
- [Configuring the Sensor \(Sensor Setup\)](#)
- [Performing Strain Balancing \(Exec Balance\)](#)
- [Bandwidth Limit \(Bandwidth\)](#)
- [Assignments to Display Groups \(Display\)](#)
- [Display Range \(Upper/Lower\)](#)
- [Range Unit \(Range Unit\)](#)
- [Inverted Waveform Display \(Invert\)](#)
- [Sample Rate \(Sample Rate\), Sample Interval \(Sample Interval\)](#)
- [Linear Scaling \(Linear Scale\)](#)
- [Shunt Calibration](#)

Waveform Input ON/OFF (Input)

You can set whether to acquire input signal waveforms for each channel.

- ON: Waveforms are acquired.
- OFF: Waveforms are not acquired.

Label (Label)

▶ [See here.](#)

Vertical Scale (SCALE knob)

You can select one of the following measurement ranges.

If μ STR Is Selected

500 μ STR, 1000 μ STR, 2000 μ STR, 5000 μ STR, 10000 μ STR, 20000 μ STR

For the measurement range, see section 7.15 in the *Getting Started Guide* (IM DL950-03EN).

If mV/V Is Selected

0.25 mV/V, 0.5 mV/V, 1 mV/V, 2.5 mV/V, 5 mV/V, 10 mV/V

For the measurement range, see section 7.15 in the *Getting Started Guide* (IM DL950-03EN).

The number that appears to the right of the range display is the maximum input at the current bridge voltage converted into a voltage value. It is the maximum input voltage for the selected range.

Configuring the Sensor (Sensor Setup)

Bridge Voltage (Excitation)

You can select the voltage to be applied to the bridge head.

- 2 V: When the bridgehead resistance (bridge resistance) is 120 Ω to 1000 Ω
- 5 V:* When the bridge resistance is 350 Ω to 1000 Ω
- 10 V:* When the bridge resistance is 350 Ω to 1000 Ω

You cannot change the bridge voltage during waveform acquisition.

- * The bridge voltage can be set to 5 V or 10 V only when:
- The bridge resistance is 350 Ω or more.
 - The strain gauge transducer supports a bridge voltage of 5 V or 10 V.

Gauge Factor (Gauge Factor)

You can set the gauge factor of the strain gauge.

Selectable range: 1.90 to 2.20 (in steps of 0.01)

The gauge factor is a constant that is unique to the gauge. It should be listed in the manual or other documentation for your gauge. You cannot change the gauge factor during waveform acquisition.

Gauge Factor When mV/V Is Selected (Gauge Factor: K)

On the instrument, you can specify the gauge factor. If there is no recommended gauge factor for the strain gauge transducer, set the gauge factor to 2.00. For factors other than 2.00, e is computed in the instrument using the following equation.

$$e = (4/K) \times (V/E)$$

e: The measured value of the strain gauge transducer (mV/V).

V: The measured bridge voltage (mV)

E: The applied bridge voltage (V)

K: The gauge factor

When you change the unit of a channel, the units for all the items related to the channel change.

- Upper and lower limits (Upper/Lower)
- Trigger Level (Level)
- Automated measurement values of waveform parameters, cursor-measurement values, etc.

Performing Strain Balancing (Exec Balance)

Balancing automatically compensates the unbalanced portion of the bridge resistance. Balancing takes a few seconds.

Range within which balancing is performed:

- $\pm 10000 \mu\text{STR}$ (when μSTR is selected)
- $\pm 5 \text{ mV/V}$ (when mV/V is selected)

Bandwidth Limit (Bandwidth)

Set the bandwidth limit to 10 Hz, 100 Hz, 1 kHz, or Full.

▶ [See here.](#)

Assignments to Display Groups (Display)

▶ [See here.](#)

Display Range (Upper/Lower)

To display the measured waveform on the screen clearly, you can set upper and lower display range limits that are appropriate for the input.

Selectable range:

- $-3.0000\text{E}+04$ to $+3.0000\text{E}+04$ (when μSTR is selected)
- $-1.5000\text{E}+01$ to $+1.5000\text{E}+01$ (when mV/V is selected)

Set the limits so that the upper limit (Upper) is greater than the lower limit (Lower).

Range Unit (Range Unit)

Set the range unit.

- μ STR: Units of strain ($\times 10^{-6}$ strain)
- mV/V: Units of strain-gauge-transducer output*

The default setting is μ STR. The relationship between μ STR and mV/V is shown in the equation below.

$$(mV/V) = 0.5 \times (\mu\text{STR})/1000$$

Example

$$500 (\mu\text{STR}) \rightarrow 0.5 \times 500 (\mu\text{STR})/1000 = 0.25 (mV/V)$$

- * A unit that corresponds to the strain gauge transducer's output. It indicates the amount of transducer output in mV that corresponds to 1 V of applied bridge voltage. On the instrument, the bridge voltage (excitation: applied bridge voltage) can be set to 2 V, 5 V, or 10 V, but the mV/V values are converted and displayed, so the measured values normally remain constant.

Inverted Waveform Display (Invert)

▶ [See here.](#)

Sample Rate (Sample Rate), Sample Interval (Sample Interval)

▶ [See here.](#)

Linear Scaling (Linear Scale)

▶ [See here.](#)

The 701271 (STRAIN_DSUB) supports [shunt calibration](#).



- When you measure strain, be sure to perform balancing.
- Set the bridge voltage to 5 V or 10 V only when the bridge resistance is 350 Ω or greater. The strain will not be measured properly if you apply a bridge voltage of 5 V or 10 V when the bridge resistance is 350 Ω or less.
- If using a strain gauge transducer, use a bridge voltage in the recommended voltage range of the transducer.
- Balancing cannot be performed if there is no strain measurement bridge (bridgehead) or strain gauge transducer connected to the channel that you are trying to perform balancing on.
- When you perform balancing on all channels, if balancing fails on even one of the channels, an error message will appear along with information about the channels for which balancing failed.
- After you turn on the power, connect a new strain gauge, or change the measurement range, bridge voltage, or gauge factor, you need to perform balancing again before you perform measurement. The scale value is displayed as "imbalance" immediately after you turn on the power or when you change the range. In this kind of situation, perform balancing.
- When you change the unit of a channel, the units for all the items (the upper and lower limits (Upper/Lower), trigger level (Level), automated measurement values of waveform parameters, cursor-measurement values, etc.) related to the channel change.

Shunt Calibration (Only on the 701271 (STRAIN_DSUB))

The 701271 Strain Module (STRAIN_DSUB) supports shunt calibration.

Shunt calibration is a type of scaling in which the strain measurement gain is adjusted through the connection in parallel of a known resistance (the resistance for shunt calibration, hereinafter referred to as the shunt resistance) to the strain gauge. The 701271 Strain Module (STRAIN_DSUB) has a built-in relay circuit for shunt calibration.

To perform shunt calibration, you need a bridgehead (701957/701958) that supports shunt calibration.

When correcting the gain on the negative side (normal)

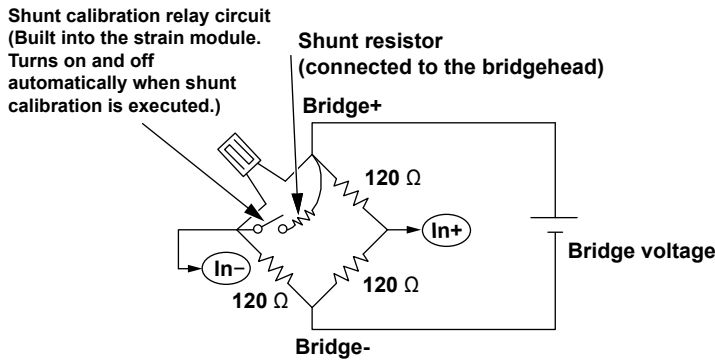

When correcting the gain on the positive side

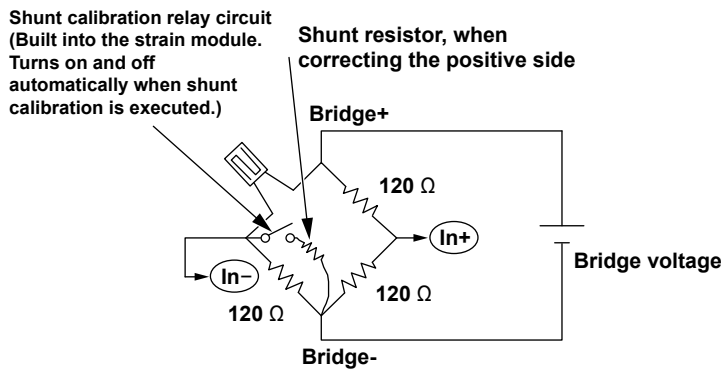

On the instrument, in addition to performing normal shunt calibration (when the shunt-calibration relay circuit is on), you can also set the zero-point value when the relay circuit is off. The zero-point value is valid when the strain value after balancing is performed is not 0.

Linear Scaling Modes (Scaling Mode)

- **Shunt**

Select this to execute shunt calibration.

The other linear scaling modes are the same as those listed for voltage measurement.

▶ [See here.](#)

- **P1[X]**
When shunt calibration (Shunt Cal Exec) is performed, the input value when the relay circuit is off is applied.
- **P1[Y]**
Set the value for when the relay circuit is off (normally 0).
- **P2[X]**
When the relay circuit is on and shunt calibration (Shunt Cal Exec) is performed, the input value when the relay circuit is on is applied.
- **P2[Y]**
Set the strain value that corresponds to the shunt resistance when the relay circuit is on.

Shunt calibration

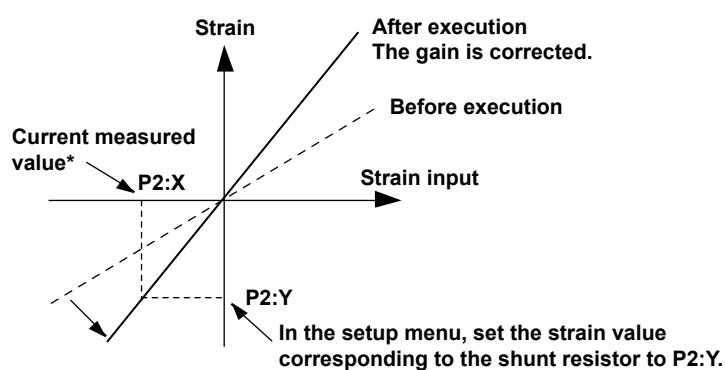

* Obtained automatically when shunt calibration is performed

Shunt Calibration Execution (Shunt Cal Exec)

Executes shunt calibration.

Unit (Unit)

You can set the unit using up to four alphanumeric characters.

Display Type (Display Type)

The same as the linear scaling settings for voltage measurement.

▶ [See here.](#)

For details on shunt calibration, see [appendix 5](#).



- When performing shunt calibration, select an appropriate range so that the measured values do not go over the range when the shunt calibration relay circuit is on. This instrument tries to perform shunt calibration in the current set range.
- An error message will appear if shunt calibration fails (because of out-of-range values or some other reason). When this happens, change the range, and perform shunt calibration again.

Acceleration Measurement

For acceleration measurement, the items that have to be set for each input signal (CH1 to CH16) include vertical scales, the vertical positions, input coupling, the bias, the bandwidth limit, the zoom method, the gain, trace settings, sensitivity, and the unit.

The 701275 (ACCL/VOLT) acceleration module (with AAF) can measure acceleration by using the signal from an acceleration sensor. You can connect it directly to an acceleration sensor with a built-in amp.

Load-output-type acceleration sensors without amp circuits cannot be connected directly to the 701275 (ACCL/VOLT). For information about how to connect acceleration sensors, see section 3.12 in the *Getting Started Guide*, IM DL950-03EN.

Waveform Input ON/OFF (Input)

You can set whether to acquire input signal waveforms for each channel.

- ON: Waveforms are acquired.
- OFF: Waveforms are not acquired.

Label (Label)

▶ [See here.](#)

Vertical Scale (SCALE knob)

▶ [See here.](#)

Input Coupling (Coupling)

To measure acceleration with the 701275 (ACCL/VOLT), set the input coupling to ACCEL.

To measure voltage, set the input coupling to an appropriate voltage measurement setting.

▶ [See here.](#)

Bias (Bias)

Select whether to supply bias current to the acceleration sensor.

- ON: Bias current is supplied to the acceleration sensor.
- OFF: Bias current is not supplied to the acceleration sensor.



-
- Do not connect an acceleration sensor when Bias is set to ON. Doing so may damage the instrument.
 - The bias current is 4 mA.
-

Bandwidth Limit (Bandwidth)

Set the bandwidth limit to 40 Hz, 400 Hz, 4 kHz, Auto, or Full.

When you set the bandwidth limit to Auto, an anti-aliasing filter (AAF) and low-pass filter are set in accordance with the sample rate, and high-frequency noise is removed from the input signal. By using an anti-aliasing filter when you measure voltages, you can remove the aliasing in the FFT.

▶ [See here.](#)



The filter is effective not only during acceleration measurement but also during voltage measurement.

Assignments to Display Groups (Display)

▶ [See here.](#)

Zoom Method (V Scale)

▶ [See here.](#)

Waveform Vertical Position (Vertical POSITION knob)

▶ [See here.](#)

Zooming by Setting a Magnification (V Zoom)

▶ [See here.](#)

Zooming by Setting Upper and Lower Display Limits (Upper/Lower)

▶ [See here.](#)

Gain (Gain)

You can set the ratio of the output signal to the input signal to a value from 0.1 to 100.
The default setting is $\times 1$.

Sensitivity (Sensitivity)

Set the sensitivity of the acceleration sensor in the range of 0.10 mV/Unit to 2000.00 mV/Unit.

Sample Rate (Sample Rate), Sample Interval (Sample Interval)

▶ [See here.](#)

Unit (Unit)

Set the unit of acceleration to be displayed using up to four characters. The default setting is m/s^2 . Change the unit as necessary.

Frequency Measurement

For frequency measurement, the items that have to be set for each input signal (CH1 to CH16) include vertical scales, the vertical positions, FV settings, the input settings, the zoom method, the offset, trace settings, and linear scaling.

You can connect a sensor or probe to the 701281 (FREQ) or 720281 (FREQ) frequency module and measure frequencies, revolutions, periods, duty cycles, power supply frequencies, pulse widths, pulse integration, and velocities.

For the sensor connection method, see section 3.13 in the *Getting Started Guide*, IM DL950-03EN. For the probe connection method, see section 3.6.

- [Waveform Input ON/OFF \(Input\)](#)
- [Label \(Label\)](#)
- [Vertical Scale \(SCALE knob\)](#)
- [Waveform Vertical Position \(Vertical POSITION knob\)](#)
- [FV Setup \(FV Setup\)](#)
- [Input Setup \(Input Setup\)](#)
- [Filter \(Filter\)](#)
- [Assignments to Display Groups \(Display\)](#)
- [Zoom Method \(V Scale\)](#)
- [Zooming by Setting a Magnification \(V Zoom\)](#)
- [Offset \(Offset\)](#)
- [Zooming by Setting Upper and Lower Display Limits \(Upper/Lower\)](#)
- [Sample Rate \(Sample Rate\), Sample Interval \(Sample Interval\)](#)
- [Linear Scaling \(Linear Scale\)](#)

Waveform Input ON/OFF (Input)

You can set whether to acquire input signal waveforms for each channel.

- ON: Waveforms are acquired.
- OFF: Waveforms are not acquired.

Label (Label)

▶ [See here.](#)

Vertical Scale (SCALE knob)

▶ [See here.](#)

Waveform Vertical Position (Vertical POSITION knob)

▶ [See here.](#)

FV Setup (FV Setup) - frequency measurement

Measured Item (Function)

You can choose one of the following items to measure.

- **Frequency (Frequency)**

Frequency (Hz) = $1 \div T_w$ (s)

Measurable range: 0.01 Hz to 500 kHz

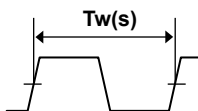

- **Revolution (rpm)/ Revolution (rps) (Revolution (rpm)/Revolution (rps))**

Revolutions (rpm) = Frequency (Hz) ÷ pulses per revolution (Nr) × 60

Measurable range: 0.01 rpm to 100000 rpm

Revolutions (rps) = Frequency (Hz) ÷ pulses per revolution (Nr)

Measurable range: 0.001 rps to 2000 rps

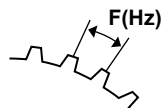

Number of pulses per rotation: Nr

- **Period (Period)**

Period (s) = Tw (s)

Measurable range: 2 μs to 50 s

- **Duty Cycle (Duty)**

Duty (%) = Thigh (s) ÷ Tw (s)

Or, Duty (%) = Tlow (s) ÷ Tw (s)

Measurable range: 0 % to 100 %

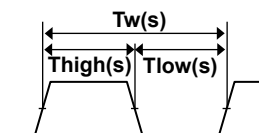

- **Power Frequency (Power Freq.)**

Power supply frequency (Hz) = 1 ÷ Tw (s)

Resolution: 0.01 Hz

Measurable range: (50 Hz, 60 Hz, 400 Hz) ± 20 Hz

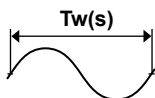

- **Pulse width (Pulse Width)**

Pulse width (s) = Thigh (s)

Or, pulse width (s) = Tlow (s)

Measurable range: 1 μs to 50 s



- **Pulse Integration (Pulse Integ)**

Pulse integration = N (count) × physical amount per pulse (I)

Set the physical amount per pulse (I) to the distance or flow rate.

A suitable user-defined unit can be assigned to the specified physical amount.

Measurable range: Up to 2×10⁹ counts

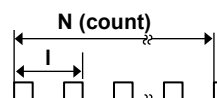

2 Channel Setup

- **Velocity (Velocity)**

Velocity (km/h) = distance per pulse l (km) \div T_w (s) \times 3600

Velocity (m/s) = distance per pulse l (m) \div T_w (s)

You can define unique distances and units (angular velocity and other units).

Measurable range: F ($= 1/T_w$) = 0.01 Hz to 500 kHz

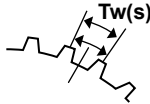

Distance per pulse (l)

Settings for Each Item

When Measuring Revolutions

- **Pulses per Rotation (Pulse/Rotate)**

Set the number of pulses per revolution to a value from 1 to 99999.

When Measuring Duty Cycles or Pulse Widths

- **Measured Pulse (Measure Pulse)**

Set the type of pulse to measure to Positive or Negative.

When Measuring Duty Cycles

- Positive: The rising-pulse percentage is measured.
- Negative: The falling-pulse percentage is measured.

When Measuring Pulse Widths

- Positive: The rising-pulse width is measured.
- Negative: The falling-pulse width is measured.

When Positive Is Selected When Negative Is Selected

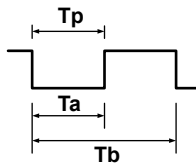
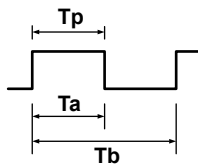

Pulse width:
The width of T_p is measured.
Duty:
 T_a/T_b is measured.

- **Timeout Value (Time Out)**

Set the timeout period for duty cycle measurement. If the pulse polarity does not change for longer than the specified time, the duty cycle is not measured.

Selectable range: 0.00001 s (10 μ s) to 80 s. The default setting is 10.00100 s.

Resolution: 0.00001 s (10 μ s)

The duty cycle when a timeout occurs is 0 % or 100 %.

- Duty cycle (%) when the measurement pulse setting is Positive
 - 0 %: When the input signal is at low level and timeout occurs
 - 100 %: When the input signal is at high level and timeout occurs
- Duty cycle (%) when the measurement pulse setting is Negative
 - 0 %: When the input signal is at high level and timeout occurs
 - 100 %: When the input signal is at low level and timeout occurs



The timeout period can be set on the 701281 (FREQ) (with module version 0x04 and later) and 720281 (FREQ).

When Measuring Power Supply Frequency

- **Center Frequency (Center Frequency)**

Set the center frequency to 50 Hz, 60 Hz, or 400 Hz.

When Measuring Pulse Integration

- **Unit/Pulse Setting (Unit/Pulse)**

You can set the physical amount per pulse to a value from $-9.9999E+30$ to $9.9999E+30$.

- **Unit (Unit)**

You can set the displayed pulse-integration unit as necessary using up to four characters.

- **Over Limit Reset (Over Limit Reset)**

Select ON to reset the pulse count automatically when the range is exceeded. If you do not want to reset the pulse count, select OFF. The default setting is OFF.

- **Manual Reset (Reset)**

To manually reset the pulse count, select Exec.

When Measuring Velocity

- **Distance per Pulse (Distance/Pulse)**

You can set the distance per pulse to a value from $-9.9999E+30$ to $9.9999E+30$.

- **Time Unit (Time Unit)**

You can set the unit of time to hour, min, or sec.

The output is automatically converted to velocity based on the specified time unit.

- **Unit (Unit)**

Set the unit of velocity to be displayed using up to four characters. The default setting is m/s.

Filter (Filter)

• **Smoothing (Smoothing)**

The frequency module can display waveforms using real-time moving averages of the data. The moving average order can be set through the specification of a time value from 0.0 ms to 1 s (the maximum number of averages is 25000). The number of averages performed (moving average order) = the specified time ÷ 40 μs.

The smoothing filter has the following characteristics.

- Smooths out staircase patterns.
- Enables you to reduce measurement jitter and increase the resolution. Because of the increased resolution, you can perform high-precision measurements, especially when you measure high frequencies or use the offset feature and enlarge the waveform.
- Can be used with all frequency-module measurement items.

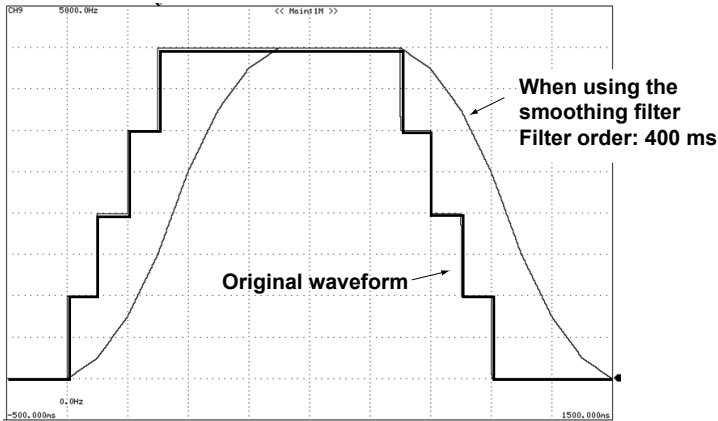

When using the offset function and making measurements by expanding near 100 kHz

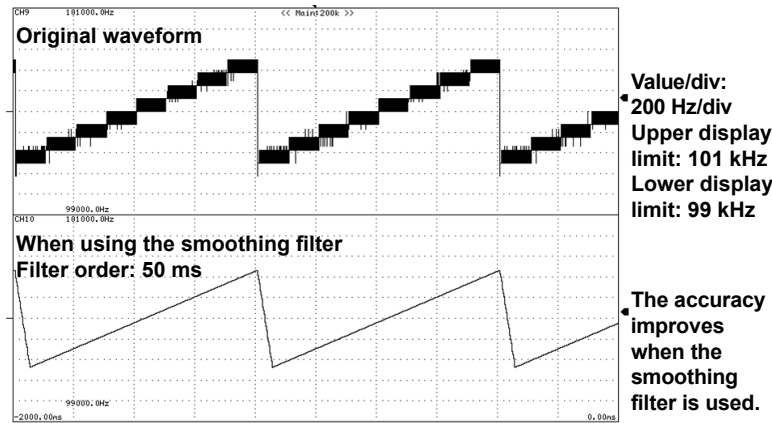

- **Pulse Average (PulseAverage)**

The input pulses are divided into groups of a specified number (1 to 4096 pulses) and measured. Pulse averaging has the following characteristics.

- Enables you to eliminate the effects of missing pulses and inconsistent pulse intervals (inconsistencies in the frequency or period waveform) on measurement.
- Even if you use pulse averaging, the measured results are displayed as per-pulse values, so there is no need to reperform scaling.
- Pulse averaging can be used in measurements of frequencies, revolutions, periods, power supply frequencies, pulse integration, and velocities.

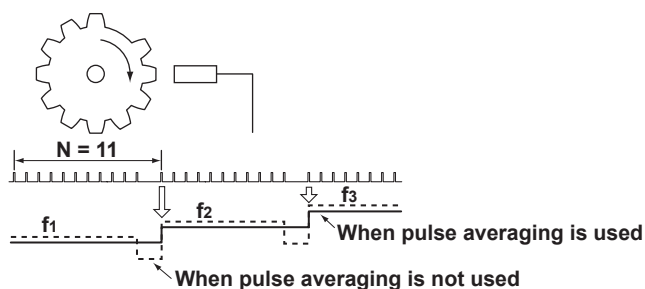

Deceleration and Stop Prediction

The 701281 (FREQ) or 720281 (FREQ) automatically performs internal computation and displays waveforms by predicting the deceleration curve and stop point even when the input pulse is suddenly cut off. This function enables the measurement of waveforms of deceleration behavior that are close to the actual physical phenomenon in applications in which the deceleration behavior of an object that has inertia is measured, such as in automobile brake tests.

- **Deceleration Prediction (Deceleration Prediction)**

The deceleration curve is computed according to the following equation using the elapsed time after the pulse input stops (Δt).

$$\text{Frequency (f)} = 1/\text{elapsed time } (\Delta t)$$

The deceleration prediction starts after the pulse input stops and a pulse period (T) of the pulse one period before the pulse input stopped elapses.

- **Stop Prediction (Stop Prediction)**

The point at a specified time after the pulse input stops is considered a stop point, and the frequency is set to 0. The time from the point when the pulse input stops to the point when the instrument determines that the object has stopped can be set to 1.5, 2, 3, ..., 9, or 10 times (10 options) the pulse period (T) of the pulse one period before the pulse input stopped.

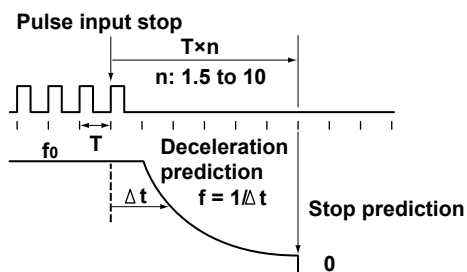

Input Setup (Input Setup) - Frequency Measurement

Presets (Preset)

When you select a preset, the instrument automatically configures appropriate settings for all the signals (for some preset options, there are some settings that you will need to configure). You can select User to set all the settings to user-defined values. There are 10 types of presets. For details about the settings of each preset, see appendix 7.

- **Logic 5V, Logic 3V, Logic 12V, Logic 24V (Logic 5V, Logic 3V, Logic 12V, Logic 24V)**

Use this preset when the output from the sensor or other equivalent item changes in the range of 0 V to 5 V (or 3 V, 12 V, or 24 V: supply voltage applied to the sensor). The voltage range is automatically set to the optimum voltage range, and the threshold level is automatically set to one-half the voltage.

- **Pull-up 5V (Pull-up 5V)**

Use this preset when the sensor output is open collector or contact output. The pull-up function is enabled only when this preset is selected. The pull-up voltage is approximately 5 V, and the pull-up resistor is 10 k Ω . If you enable the pull-up function, set the input voltage to a value from 0 V to 5 V. If the input voltage exceeds this range, the protection circuit is tripped, and the pull-up resistor is automatically cut off.

- **Zero Cross (ZeroCross)**

Use this preset when the input voltage changes around 0 V. The input coupling is automatically set to AC, and the threshold level is automatically set to 0 V. When you set the voltage range, make sure that the maximum amplitude does not exceed the voltage range.

- **AC100V, AC200V**

Use this preset when measuring the supply voltage of 100 V or 200 V power supply systems. The probe type is automatically set to 10:1, the voltage range is automatically set to a value suitable for the input voltage and probe factor, and the coupling is automatically set to AC. Be sure to use the isolated probe (700929) when measuring the power supply voltage.

- **EM Pickup (EM Pickup)**

Use this preset when connecting an electromagnetic pickup directly. The voltage range is automatically set to ± 1 V, and the threshold level is automatically set to 0 V.

- **User-Defined (User)**

Use this preset to configure user-defined input conditions. The pull-up function cannot be enabled.



-
- When measuring high voltages exceeding 42 V (AC+DCpeak) on the 701281 (FREQ) or 720281 (FREQ), be sure to use the isolated probe (700929).
 - Use EM Pickup only when connecting an electromagnetic pickup.
 - When the EM Pickup preset is selected, the LEDs of the frequency module do not illuminate in red, even when the range is exceeded.
 - The instrument does not support electromagnetic pickups that need to have power supplied to them or pickups that require terminators at the output. Handle these types of electromagnetic pickups using sensors.
 - Keep the output of the electromagnetic pickup within 42 V_{P-P}. The minimum sensitivity is 0.2 V_{P-P}. If the output is less than the minimum sensitivity, the measured values may be unstable.
 - When you use the pull-up function, do not let the voltage go outside the range of 0 to 5 V. If the voltage goes outside of this range, the protection circuit will be tripped, and the pull-up circuit will be cut off.
-

The following 9 setup items are available.

Voltage Range (V Range)

You can set the input voltage range (\pm FS) to one of the options below.

- When the probe attenuation (Probe) is set to 1:1
 ± 1 V, ± 2 V, ± 5 V, ± 10 V, ± 20 V, ± 50 V (\pm FS)
- When the probe attenuation (Probe) is set to 10:1
 ± 10 V, ± 20 V, ± 50 V, ± 100 V, ± 200 V, ± 500 V (\pm FS)

Input Coupling (Coupling)

You can set the input coupling to DC or AC.

▶ [See here.](#)

Probe Type (Probe)

You can set the probe type to 1:1 or 1:10.

▶ [See here.](#)

Bandwidth Limit (Bandwidth)

Set the bandwidth limit to 100 Hz, 1 kHz, 10 kHz, 100 kHz, or Full. You cannot select Full when Preset is set to AC100 V or AC200 V.

▶ [See here.](#)

Threshold Level (Threshold)

You can set the level within the FS of the input voltage range. The resolution is the value that corresponds to 1 % of the FS.

Hysteresis (Hysteresis)

You can set the hysteresis to ~~1~~(± 1 %), ~~2.5~~(± 2.5 %), or ~~5~~(± 5 %) of the FS of the input voltage range.

Slope (Slope)

Select \nearrow (rising) or \searrow (falling).

Chatter Elimination (Chatter Elimination)

Eliminates the chattering that occurs in cases such as when the contact input is turned on or off. The changes in the signal over the specified time can be discarded. You can set the interval to a value from 0 to 1000 ms (in 1 ms steps). When 0 ms is selected, chatter elimination is turned off.

Chatter elimination works on both rising and falling edges.

2 Channel Setup

Pull Up (Pull Up)

You can choose whether to enable the pull-up function only when Preset is set to Pull-up 5V. You cannot configure the pull-up setting when another preset is selected.

If you enable the pull-up function, set the input voltage to a value from 0 V to 5 V. If you apply a voltage that is outside of this range, the internal protection circuit will cut off the pull-up circuit.

Internal Equivalent Circuit for When the Pull-up Function Is Enabled

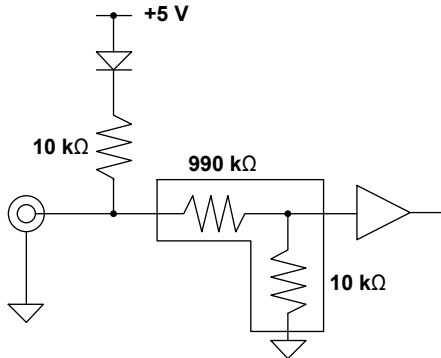

Digital Filter (Filter)

You can select the digital filter on models with the /G03 or /G05 option.

▶ [See here.](#)

Assignments to Display Groups (Display)

▶ [See here.](#)

Zoom Method (V Scale)

▶ [See here.](#)

Zooming by Setting a Magnification (V Zoom)

▶ [See here.](#)

Offset (Offset)

▶ [See here.](#)

Zooming by Setting Upper and Lower Display Limits (Upper/Lower)

▶ [See here.](#)

Sample Rate (Sample Rate), Sample Interval (Sample Interval)

▶ [See here.](#)

Linear Scaling (Linear Scale)

▶ [See here.](#)

Logic Measurement

For logic measurement, the items that have to be set for each input signal (CH1 to CH16) include vertical positions, the logic bit settings, the logic bit mapping, the zoom method, and trace settings.

You can measure logic signals by connecting a logic probe to the 720230 (LOGIC) logic module.

For information about how to connect logic probes, see section 3.11 in the *Getting Started* Guide, IM DL950-03EN.

Waveform Input ON/OFF (Input)

You can set whether to acquire input signal waveforms for each channel.

- ON: Waveforms are acquired.
- OFF: Waveforms are not acquired.

Label (Label)

▶ [See here.](#)

Waveform Vertical Position (Vertical POSITION knob)

▶ [See here.](#)

Bit Setup (Bit Setup)

Bit Display On/Off (Display)

Select whether to show or hide the waveform of each bit.

Bits 1 to 8 (Bit1 to Bit8), all bits on (All Bits On), all bits of (All Bits Off)

Bit Name (Bit Name)

You can assign labels to bits using up to sixteen characters.



Depending on the display and zoom formats, label names may not appear when the waveform display is narrow.

Chatter Elimination (Chatter Elimination)

For each bit, you can set whether to eliminate chattering. When eliminating chattering, set the elimination time. OFF, 5 msec, 10 msec, 20 msec, 50 msec, 100 msec

Bit Mapping (Bit Mapping)

- Fixed: Spaces are allocated for bits that are turned off.
- Auto: Spaces are not allocated for bits that are turned off. Only the bits that are turned on are displayed. The bits are displayed in order from the top.

Fixed (When bit 7 is off)

A1
A2
A3
A4
A5
A6
A8

Auto (When bit 7 is off)

A1
A2
A3
A4
A5
A6
A8

Deskewing (Skew Adjustment)

▶ [See here.](#)

Sample Rate (Sample Rate), Sample Interval (Sample Interval)

▶ [See here.](#)

Zooming by Setting a Magnification (V Zoom)

▶ [See here.](#)

Assignments to Display Groups (Display)

▶ [See here.](#)

Note about Logic Measurement

In the logic settings in the preferences, you can set the display format (Bit or Hex), the cursor order, and the bit order.

▶ [See here.](#)

CAN and CAN FD Bus Signal Monitoring (/VCE option)

This feature is applicable only for the /VCE option.

- You can monitor CAN bus signals using the 720240 CAN bus monitor module or the 720241 CAN & LIN bus monitor module.
- You can monitor CAN/CAN FD bus signals using the 720242 CAN/CAN FD monitor module.

The following settings are available.

- [Waveform Input ON/OFF \(Input\)](#)
- [Reading Data Frames \(CAN Port Configuration\)](#)
All sub channel setup (All Sub Channel Setup), all sub channel Factor/Offset (All Sub Channel Factor/Offset), port setup (Port Setup), symbol file load (Symbol File Load)
- [CAN/CAN FD Data Display Settings \(Sub Channel\)](#)
Display settings of sub channels 1 to 60
- [One-Shot Output Setup \(One shot out Setup\)](#)
- [All Sub Channels Scale \(All Sub Channel Scale\)](#)
- [Sample Rate \(Sample Rate\), Sample Interval \(Sample Interval\)](#)

CAN Frame Formats

Data Frames

- Standard format**

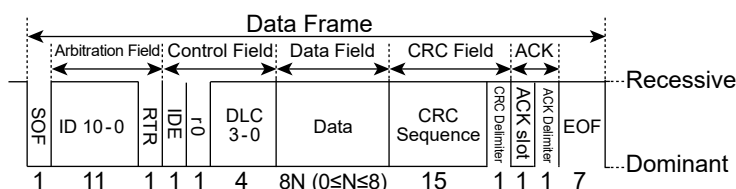

- Extended format**

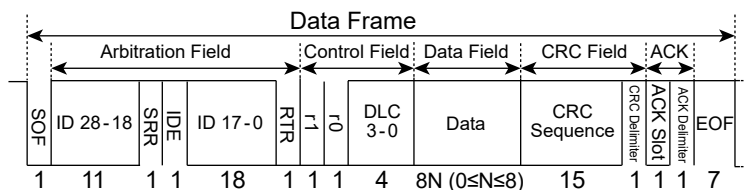

Remote Frames

- Standard format**

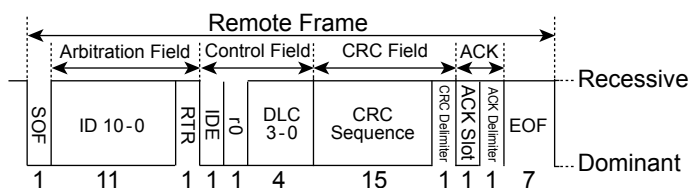

- Extended format**

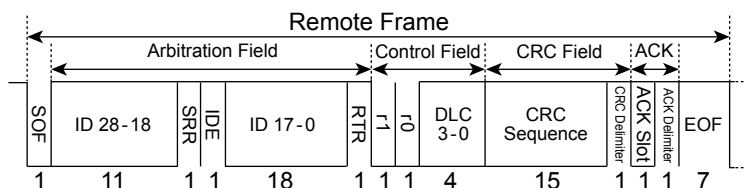

Motorola's Forward format setting is not supported.

CAN FD Frame Format

Data Frames

- Standard format

CAN FD (ISO 11898-1: 2015)

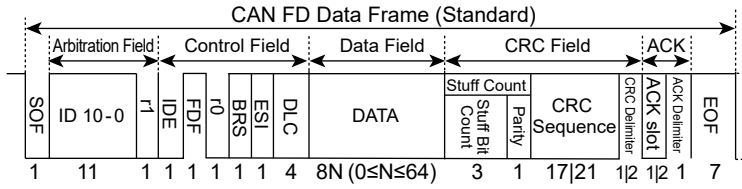

CAN FD (non-ISO)

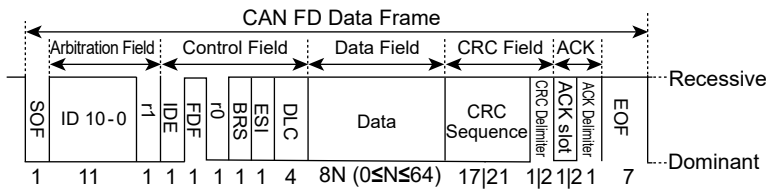

- Extended format

CAN FD (ISO 11898-1: 2015)

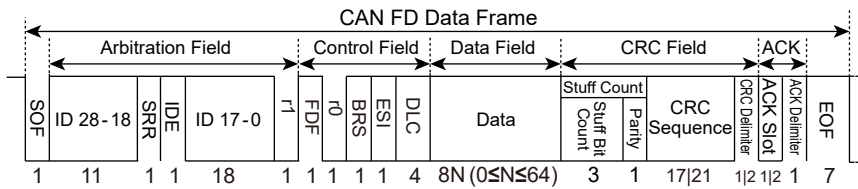

CAN FD (non-ISO)

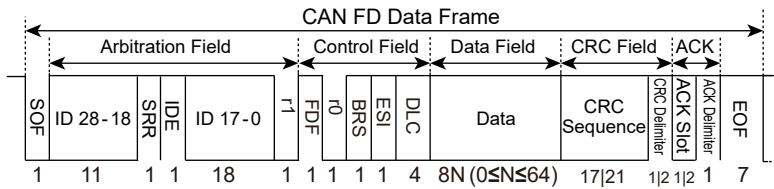

The module can be connected as a node to an ISO-11898 CAN bus. The instrument (with the /VCE option) uses the module to read the data frames transferred on the CAN bus and then extracts the specified portion of the data field (CAN data), converts it to time series data, and displays its waveform. The waveforms of up to 60 sub channels can be displayed for each module port. You can specify (define) the CAN data using Vector Informatik CANdb database files. Both the standard and extended formats are supported.

In addition, you can output single data frames or remote frames to a CAN bus at a specific time (one-shot output).

To monitor CAN/CAN FD signals, the items that have to be set include port settings, data extraction conditions, the sub channel display range, the unit of measurement, trace settings, and scaling.



- You can install a total of two 720240 CAN bus monitor modules, 720242 CAN/CAN FD monitor modules, or 720241 CAN & LIN Bus Monitor Modules. These monitor modules can only be installed in slots 7 and 8. Even if you mix these modules, you can still only install a total of two modules.
- The instrument requires the following processing times to read data frames transferred on the CAN bus. New data frames that the instrument receives during these processing times may be discarded.
 - 720240 or 720241

Number of Channels Used per Port	One Port in Operation	Two Ports in Operation
1	40 μ s	80 μ s
8	60 μ s	120 μ s
16	80 μ s	160 μ s
32	120 μ s	240 μ s
60	200 μ s	400 μ s

- 720242

The processing time is 40 μ s, regardless of the number of channels or the number of ports.

Waveform Input ON/OFF (Input)

You can set whether to acquire input signal waveforms for each port. Each port corresponds to CH13 to CH16.

- ON: Waveforms are acquired.
- OFF: Waveforms are not acquired.

Reading Data Frames (CAN Port Configuration)

- [Setting All Sub Channels \(All Sub Channel Setup\)](#)
- [All Sub channels Factor/Offset \(All Sub Channel Factor/Offset\)](#)
- [Port Setup \(Port Setup\)](#)
- [Symbol File Load \(Symbol File Load\)](#)

CAN Data Extraction Conditions (All Sub Channel Setup)

Set the extraction conditions for the CAN data that is in the data field. You can configure the settings for each sub channel. There are up to 60 sub channels for each port.

When the data field contains two units of data

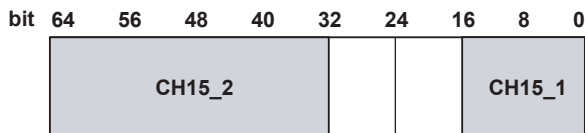

- Start Bit = 0, Bit Count = 16bit → 2-byte integer (CH15_1)
- Start Bit = 32, Bit Count = 32bit → 4-byte real (CH15_2)
4-byte real numbers can be extracted by modules whose firmware version is 1.20 and later.

Input (Input)

ON: The data is monitored.

OFF: The data is not monitored. Nor is it displayed.

Label (Label)

▶ [See here.](#)

Message Format

Select the message format of the collected data frames.

STD: Standard format

XTD: Extended format

ID (Hex)

Set the message ID of the collected data frames.

Standard format (11 bits): 0x000 to 0x7ff

Extended format (29 bits): 0x00000000 to 0x1fffffff

Byte Count

Set the method for extracting the data area of the collected data frames.

Auto: All data is extracted. Normally use this option.

1 to 8: The specified number of bytes of data are extracted. Data is extracted starting from the start of the data.

This is valid when big endian byte order is in use. When little endian byte order is in use, Byte Count is always set to Auto.

Start Bit

Specify the bit number of the data extraction starting point.

0 to 63

Bit Count

Set the number of data bits to extract. The range that you can specify varies depending on the data type.

Unsigned, Signed: 2 to 32

Float: The bit length that can be set is only 32.

Logic: 1 to 8

Byte Order

Select the method (endian) to use to store the data in the acquisition memory.

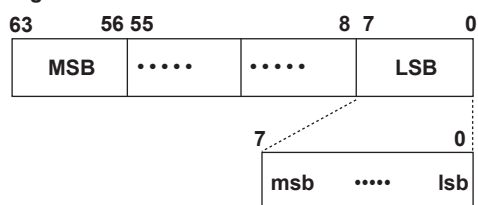
Big Endian

MSB: Most significant byte
 LSB: Least significant byte
 msb: Most significant bit
 lsb: Least significant bit

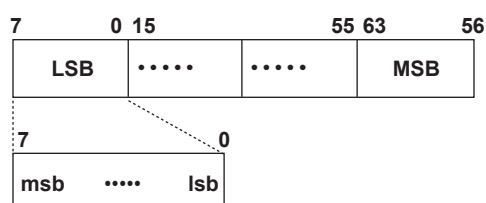
Little Endian

MSB: Most significant byte
 LSB: Least significant byte
 msb: Most significant bit
 lsb: Least significant bit

Value Type

Select the type of CAN data to extract.

Unsigned: Unsigned integer

Signed: Signed integer

Float: Real number

Logic: Boolean



You can monitor up to 60 sub channels with a single port.

If the input is turned on for all the sub channels and the bit length of each sub channel is 16 bits or less, you can monitor all 60 sub channels.

However, the amount of memory is limited, so each time that the length of a sub channel is set longer than 16 bits, the instrument turns the input of sub channels off (sets them so that they cannot be monitored) in decreasing order starting with sub channel number 60 until the memory usage is within the memory limitations.

CAN Data Conversion Conditions (All Sub Channel Factor/Offset)**Factor/Offset**

Configure these settings when the data type is set to Unsigned, Signed or Float. The Factor and Offset values that you set here are used to convert the extracted data to physical values.

Factor: Scaling coefficient (value per bit)

Offset: Offset value

Selectable range: $-10.000E+30$ to $+10.000E+30$

Unit

Using up to 16 characters, enter the unit to display for the waveform.

Port Setup (Port Setup)

- **Bit Rate (Bit Rate)**

Select the CAN bus signal transmission speed.

10 k, 20 k, 33.3 k, 50 k, 62.5 k, 66.7 k, 83.3 k, 100 k, 125 k, 200 k, 250 k, 400 k, 500 k, 800 k, 1 Mbps

- **Sample Point (Sample Point)**

Select the sample point for each bit.

720240 (CAN MONITOR), 720241 (CAN & LIN): 71 %, 78 %, 85 %

720242 (CAN/CAN FD): 65 % to 90 %

- **Synchronization Jump Width (Sync Jump Width)**

This option appears when a 720240 (CAN MONITOR) or 720241 (CAN & LIN) is installed in a slot.

Set the correction value used to synchronize the bit timing between sending and receiving nodes.

1 to 4 in units of T_q (Time Quantum)

- **Number of Samples (Bit Sample Num)**

This option appears when a 720240 (CAN MONITOR) or 720241 (CAN & LIN) is installed in a slot.

You can set the number of samples at each bit's sample point.

1: The sample point data is sampled once. We recommend that you use this setting for high-speed buses.

3: The sample point data is sampled three times. We recommend that you use this setting for slow and medium speed buses.

- **CAN FD**

- **CAN FD Standard (FD Standard)**

This option appears when a 720242 (CAN/CAN FD) is installed in a slot.

Select the compliant standard for the CAN FD bus signal to be applied.

ISO: ISO 11898-1: 2015

non-ISO: ISO 11898-1: Standard before 2015

- **Data Bit Rate (Data Bit Rate)**

This option appears when a 720242 (CAN/CAN FD) is installed in a slot.

Select the CAN FD bus signal's data phase data transfer rate from the available settings below.

10 k, 20 k, 33.3 k, 50 k, 62.5 k, 66.7 k, 83.3 k, 100 k, 125 k, 200 k, 250 k, 400 k, 500 k, 800 k, 1 M, 2 M, 3 M, 4 M, 5 Mbps

- **Data Sample Point (Data Sample Point)**

This option appears when a 720242 (CAN/CAN FD) is installed in a slot.

Select the sample point of the CAN FD bus signal's data phase bits.

65 % to 90 %

- **Listen Only (Listen Only)**

ON: The ACK bit is not transmitted.

OFF: The ACK bit is transmitted.



One-shot output is not possible when Listen Only is set to ON.

- **Terminator (Terminator)**

ON: The 120 Ω terminator between CAN_H and CAN_L on the CAN bus line is turned on.

OFF: The terminator between CAN_H and CAN_L on the CAN bus line is turned off.

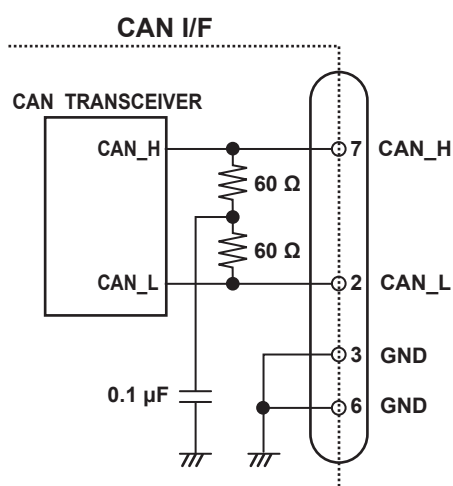

Loading a CAN/CAN FD Data Definition File (Symbol File Load)

You can configure the CAN/CAN FD data extraction conditions by loading a CAN/CAN FD data definition file (an SBL file).^{*} Data that has been edited using Symbol Editor is assigned to the instrument's sub channels 1 to 60 according to the order in the definition list (you can change the order in the Symbol Editor's definition list).^{*}

^{*} An SBL file (.SBL extension) is a CANdb file (.dbc extension) that has been converted and edited into a physical value/symbol definition file using YOKOGAWA's free Symbol Editor software. You can obtain Symbol Editor from the YOKOGAWA website (<http://www.yokogawa.com/yymi/>).

CANdb files (.dbc) are signal definition database files created using the CANdb or CANdb++ software produced by Vector Informatik.

CAN/CAN FD Data Display Settings (Sub Channel)

Sub Channels 1 to 60 (Sub Channel 1 to 16)

Configure the zoom magnification, scaling method, display range, and assignment to a display group of the specified sub channel.

Zooming by Setting the Magnification (V Zoom)

Configure this setting when Value Type is set to Logic.

Selectable range: x0.1 to x3.33

▶ [See here.](#)

Display Range (Upper/Lower)

Configure this setting when Value Type is not set to Logic.

Set the upper and lower limits of the waveform display range.

Selectable range: $-30.000E+30$ to $+30.000E+30$

Auto Scale and Default Scale (Auto Scale/Default Scale)

Configure this setting when Value Type is not set to Logic.

Auto Scale: The upper and lower display range limits are set automatically.

Default Scale: To the greatest extent possible within the settable range, the maximum and minimum values are used to set the display range setting (which is explained below) of the specified sub channel.

Assignments to Display Groups (Display)

▶ [See here.](#)

One Shot Output Settings (One shot out Setup)

A single specified data frame or remote frame is output at the specified time.

Message Type

This option appears when a 720242 (CAN/CAN FD) is installed in a slot.

Select the message type.

CAN, CAN FD

Message Format

Select the message format.

STD: Standard format

XTD: Extended format

ID (Hex)

Set the message ID of the output data frame.

Standard format (11 bits): 0x000 to 0x7ff

Extended format (29 bits): 0x00000000 to 0x1fffffff

Frame

Select the frame type.

Remote: Remote frame

Data: Data frame

DLC

Set the byte size of the data area of the data frame.

Selectable range: 0 to 15

Data (Hex)

Configure this setting when the frame type (Frame) is set to Data.

In hexadecimal notation, specify the data frame value to output.

Output

Output the data.



You cannot output the data when in the Port Setup menu, Listen Only is set to ON.

All Sub Channel Scale (All SubChannel Scale)

Configure the scales of all sub channels.

All Sub Channel Auto (All SubChannel Auto): The upper and lower display range limits are set automatically.

All Sub Channel Default (All SubChannel Default): To the greatest extent possible within the settable range, the maximum and minimum values are used to set the upper and lower limits of all sub channels.

LIN Bus Signal Monitoring (/VCE option)

You can monitor CAN and LIN bus signals using the 720241 CAN & LIN Bus Monitor Module. This feature is applicable only for the /VCE option.

For details on the CAN bus signal monitoring feature, see “CAN Bus Signal Monitoring (/VCE option).”

► [See here.](#)

The following settings are available.

- [Waveform Input ON/OFF \(Input\)](#)
- [Reading LIN Frames \(LIN Port Configuration\)](#)
All sub channel setup (All Sub Channel Setup), all sub channel Factor/Offset (All Sub Channel Factor/Offset), port setup (Port Setup), frame setup (Frame Setup), symbol file load (Symbol File Load)
- [LIN Data Display Settings \(Sub Channel\)](#)
Display settings of sub channels 1 to 60
- [All Sub Channels Scale \(All Sub Channel Scale\)](#)
- [Sample Rate \(Sample Rate\), Sample Interval \(Sample Interval\)](#)

LIN Frame Format

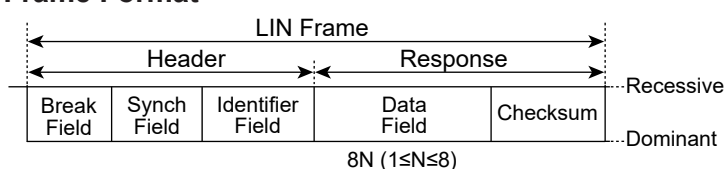

This section explains the LIN bus signal monitoring feature.

The instrument (with the /VCE option) uses the module to read the ISO-9141 signal, that is transferred on the LIN bus and then extracts the specified portion of the LIN frame (LIN data), converts it to time series data, and displays its waveform. The waveforms of up to 60 sub channels can be displayed. You can also use the LIN descriptor files (LDF) that are described in the LIN configuration language specification to specify (define) LIN data.

For LIN bus signal monitoring using a CAN & LIN Bus Monitor Module, the items that have to be set include port settings, frame settings, data extraction conditions, sub channel display range, unit of measurement, trace settings, and scaling.



- You can install up to two 720241 CAN & LIN Bus Monitor Modules in slots 7 and 8. If you install a 720240 CAN Bus Monitor Module with a 720242 CAN/CAN FD Monitor Module, you can still only install a total of two modules.
- The instrument requires the following processing times to read data frames transferred on the LIN bus. New frames that the instrument receives during these processing times may be discarded.

Number of Channels Used per Port	Only LIN Port in Operation	CAN Port in Operation at the Same Time
1	40 μs	80 μs
8	60 μs	120 μs
16	80 μs	160 μs
32	120 μs	240 μs
60	200 μs	400 μs

Waveform Input ON/OFF (Input)

You can set whether to acquire input signal waveforms for each port. Each port corresponds to CH13 to CH16.

- ON: Waveforms are acquired.
- OFF: Waveforms are not acquired.

Reading LIN Frames (LIN Port Configuration)

- [Setting All Sub Channels \(All Sub Channel Setup\)](#)
- [All Sub channels Factor/Offset \(All Sub Channel Factor/Offset\)](#)
- [Port Setup \(Port Setup\)](#)
- [Frame Setup \(Frame Setup\)](#)
- [Symbol File Load \(Symbol File Load\)](#)

LIN Data Extraction Conditions (All Sub Channel Setup)

Set the extraction conditions for the LIN data that is in the data field. You can configure the settings for each sub channel.

There are up to 60 sub channels for each port.

When the data field contains two units of data

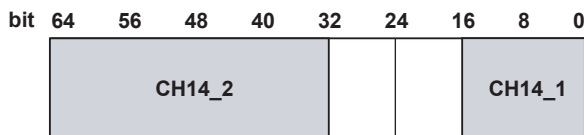

- Start Bit = 0, Bit Count = 16bit → 2 bytes (CH14_1)
- Start Bit = 32, Bit Count = 32bit → 4 bytes (CH14_2)

Input (Input)

ON: The data is monitored.

OFF: The data is not monitored. Nor is it displayed.

Label (Label)

▶ [See here.](#)

ID (Hex)

Set the ID (6 bits) of the LIN frame to acquire.

0x00 to 0x3f

Start Bit

Specify the bit number of the data extraction starting point.

0 to 63

Bit Count

Set the number of data bits to extract. The range that you can specify varies depending on the data type.

Unsigned, Signed: 2 to 32

Logic: 1 to 8

Byte Order

Select the method (endian) to use to store the data in the acquisition memory.

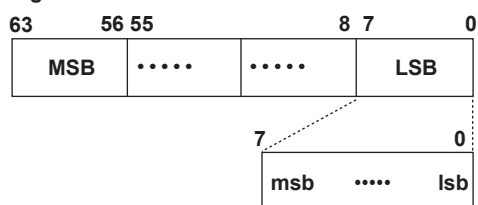
Big Endian

MSB: Most significant byte
 LSB: Least significant byte
 msb: Most significant bit
 lsb: Least significant bit

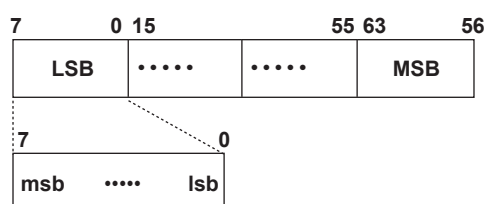
Little Endian

MSB: Most significant byte
 LSB: Least significant byte
 msb: Most significant bit
 lsb: Least significant bit

Value Type

Select the type of data to extract.

Unsigned: Unsigned integer

Signed: Signed integer

Logic: Boolean



You can monitor up to 60 sub channels with a single port.

If the input is turned on for all the sub channels and the bit length of each sub channel is 16 bits or less, you can monitor all 60 sub channels.

However, the amount of memory is limited, so each time that the length of a sub channel is set longer than 16 bits, the instrument turns the input of sub channels off (sets them so that they cannot be monitored) in decreasing order starting with sub channel number 60 until the memory usage is within the memory limitations.

LIN Data Conversion Conditions (All Sub Channel Factor/Offset)**Factor/Offset**

Configure these settings when the data type is set to Unsigned or Signed. The Factor and Offset values that you set here are used to convert the extracted data to physical values.

Factor: Scaling coefficient (value per bit)

Offset: Offset value

Selectable range: $-10.000E+30$ to $+10.000E+30$

Unit

Using up to 16 characters, enter the unit to display for the waveform.

Port Setup (Port Setup)

- **Bit Rate (Bit Rate)**

Select the LIN bus signal transmission speed.

2400, 9600, 19200 bps

Frame Setup (Frame Setup)

Set the data length and checksum method for LIN frames. You can configure these settings for each ID.

Data Length

Set the data length of the data field.

1 to 8

Checksum

Select the checksum method.

Classic, Enhanced

Loading a LIN Data Definition File (Symbol File Load)

You can configure the LIN data extraction conditions by loading a LIN data definition file (an SBL file).*

Data that has been edited using Symbol Editor is assigned to the instrument's sub channels 1 to 60 according to the order in the definition list (you can change the order in the Symbol Editor's definition list).*

* An SBL file (.SBL extension) is an LDF file that has been converted and edited into a physical value/symbol definition file using YOKOGAWA's free Symbol Editor software. You can obtain Symbol Editor from the YOKOGAWA website (<http://www.yokogawa.com/yymi/>).

A LDF file is a definitions file that has been written according to the LIN configuration language specification.

LIN Data Display Settings (Sub Channel)

Sub Channels 1 to 60 (Sub Channel 1 to 16)

Configure the zoom magnification, scaling method, display range, and assignment to a display group of the specified sub channel.

Zooming by Setting a Magnification (V Zoom)

Configure this setting when Value Type is set to Logic.

Selectable range: x0.1 to x3.33

▶ [See here.](#)

Auto Scale and Default Scale (Auto Scale/Default Scale)

Configure this setting when Value Type is not set to Logic.

Auto Scale: The upper and lower display range limits are set automatically.

Default Scale: To the greatest extent possible within the settable range, the maximum and minimum values are used to set the display range setting (which is explained below) of the specified sub channel.

Display Range (Upper/Lower)

Set the upper and lower limits of the waveform display range.

Selectable range: -30.000E+30 to +30.000E+30

Assignments to Display Groups (Display)

▶ [See here.](#)

SENT Signal Monitoring (/VCE option)

You can monitor SENT signals using the 720243 SENT monitor module. This feature is applicable only for the /VCE option.

The following settings are available.

- [Waveform Input ON/OFF \(Input\)](#)
- [Reading SENT Messages \(SENT Port Configuration\)](#)
 - All sub channel setup (All Sub Channel Setup), all sub channel Factor/Offset (All Sub Channel Factor/Offset), format setup (SENT Format Setup), error channel setup (Error Channel Setup), probe setup (Input Setup)
- [SENT Data Display Settings \(Sub Channel\)](#)
 - Sub channel 1: FastCH to 11: Error Count display settings
- [Sample Rate \(Sample Rate\), Sample Interval \(Sample Interval\)](#)

SENT Message Format

Fast CH

- Up to 6 nibbles (24 bits) of data can be sent.
- The size of the value is expressed with the pulse width. 0: 12 ticks to 15: 27 ticks

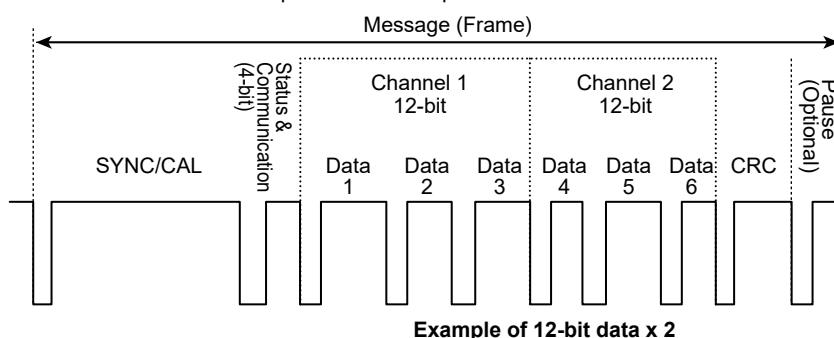

Slow CH

- Composed of bits 2 and 3 of the S&C (Status & Communication) nibble of multiple Fast CH data.
- Sends data that changes slowly and error information.
- Three types of formats (data size 8-bit, 12-bit, 16-bit) are available.

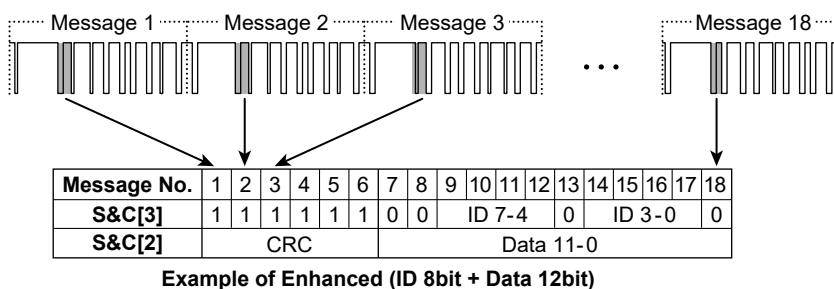

This module reads SENT signals based on SAE J2716, extracts the specified portion of the SENT message, converts it to time series data, and displays its waveform. This module has two ports. For each port, the waveforms of up to 11 sub channels can be displayed.

For SENT signal monitoring using a SENT monitor module, the items that have to be set include format, error channel, probe, data extraction conditions, sub channel display range, unit of measurement, trace settings, and scaling.



You can install up to four 720243 SENT monitor modules in slots 5 to 8.

Waveform Input ON/OFF (Input)

You can set whether to acquire input signal waveforms for each port. Each port corresponds to CH9 to CH16.

- ON: Waveforms are acquired.
- OFF: Waveforms are not acquired.

Reading SENT Messages (SENT Port Configuration)

- [Setting All Sub Channels \(All Sub Channel Setup\)](#)
- [All Sub channels Factor/Offset \(All Sub Channel Factor/Offset\)](#)
- [Format Setup \(SENT Format Setup\)](#)
- [Setting Error Channels \(Error Channel Setup\)](#)
- [Probe Setup \(Input Setup\)](#)

Format Setup (SENT Format Setup)

Set the message format for SENT signals.

ClockTick (Clock Tick)

Set the reference clock period of SENT signals. The time between consecutive falling edges of the signal is counted using this period. The clock tolerance is fixed at $\pm 20.0\%$.

Selectable range: 1.00 μs to 100.00 μs . The default setting is 3.00 μs .

Resolution: 0.01 μs

Data Nibble Number (Data Nibble Number)

Set the number of data nibbles of Fast CH messages.

Selectable range: 1 to 8. The default setting is 6.

Pause Pulse (Pause Pulse)

Select whether to include pause pulses in Fast CH messages.

ON: Pause pulses are included.

OFF: Pause pulses are not included.

CRC Type (CRC Type)

Select the CRC type.

Legacy: CRC is added using the type recommended in version FEB2008 and older.

Recommended: CRC is added using the type recommended in version JAN2010.

Slow CH Type (SlowCH Type)

Select the Slow CH message format.

Short (ID 4bit + Data 8bit): 4 bit message ID and 8 bit data field

Enhanced (ID 8bit + Data 12bit): 8 bit message ID and 12 bit data field

Enhanced (ID 4bit + Data 16bit): 4 bit message ID and 16 bit data field

Fast Channel Multiplexing (Fast Channel Multiplexing)

Select whether to handle (ON) or not handle (OFF) fast channel multiplexing.

ON: You can [specify FC](#) and set the sub channel 5 to 9 [data type](#) to Fast CH.

OFF: The FC setup menu does not appear. Sub channels 5 to 9 data type is fixed to Slow CH.



Fast channel multiplexing can be handled when the 720243 (SENT) module version is 0x07 or later.

Error Channel Setup (Error Channel Setup)

For each of the following error types, set whether to detect them as errors, whether to display triggers, and whether to count them as errors. By default, the error detection of Successive Calibration Pulses (Option2) is off, and all other items are on.

Error Type	Error Detection (Detect)	Trigger Display (Error Trigger)	Error Count (Error Count)
Fast Channel CRC	Always ON	ON or OFF	ON or OFF
Slow Channel CRC	Always ON	ON or OFF	ON or OFF
Nibble Value	Always ON	ON or OFF	ON or OFF
Successive Calibration Pulses (Option2)	ON or OFF	ON or OFF	ON or OFF
Pulse Number	Always ON	ON or OFF	ON or OFF

ON: enable, OFF: disable

Error Detection

- **Fast Channel CRC**

An error is detected when the CRC Nibble value of the Fast CH message is different from the value calculated using the specified CRC type (explained earlier). If an error is detected, the data in the Fast CH message is not used to update the Fast CH data. Nor is the Slow CH data that includes a Fast CH message updated.

- **Slow Channel CRC**

An error is detected when the CRC value of the Slow CH data obtained from the Fast CH message S&C Nibble value is not correct. If an error is detected, the Slow CH data is not updated.

- **Nibble Value**

An error is detected when the nibble length of S&C, data, or CRC is outside the 12 to 27 tick range after a SYNC/CAL pulse of the Fast CH message is detected. If an error is detected, the data in the Fast CH message is not used to update the Fast CH data. Nor is the Slow CH data that includes a Fast CH message updated.

- **Successive Calibration Pulses (Option2)***

An error is detected, when as a result of comparing the SYNC/CAL pulse of the current Fast CH message to the last preceding valid SYNC/CAL pulse, their difference is 1/64 tick or greater. If an error is detected, the data in the Fast CH message is not used to update the Fast CH data.

However, if three consecutive errors are detected, the third SYNC/CAL pulse is considered as valid, and the third Fast CH message data is used to update the Fast CH data.

* The instrument uses the "Option 2" detection method as defined in SAE J2716.

- **Pulse Number**

An error is detected when the number of SYNC/CAL pulses of the current Fast CH message and the number of the next SYNC/CAL pulses are different from the specified value (the number of data nibbles explained earlier, Pause Pulse ON/OFF). If no other errors are detected, the data in the Fast CH message is used to update the Fast CH data. The Slow CH data that includes a Fast CH message is also updated.



If a SYNC/CAL pulse is not detected within the timeout period explained later, all Fast CH and Slow CH data are set to zero. This is not detected as an error.

2 Channel Setup

Trigger Display (Error Trigger)

If an error is detected, the pulse waveform is displayed for two sampling periods of the SENT module.

Error Count (Error Count)

An error is counted when any of the error types is detected. This shows the total number of errors.

Maximum count: 65535

Error Count Reset (Error Count Reset on Start)

Set whether to reset the error count to zero when waveform acquisition is started with the START/STOP key on the front panel.

ON: The count is reset.

OFF: The count is not reset.

Manual Error Count Reset (Error Count Reset on Start)

You can manually reset the error count to zero.

Probe Setup (Input Setup)

Set the probe attenuation and the timeout value for SENT signal input. The threshold level is fixed.

Probe Attenuation (Probe)

Select the attenuation of the probes connected to SENT ports.

1:1, 10:1

Threshold Level (Threshold H, Threshold L)

The threshold level for determining whether the SENT signal is high or low level is fixed.

Threshold H: 3.5 V

Threshold L: 1.5 V

* The SENT module voltage range is fixed at ± 20 V.

Timeout Value (Time Out)

Set the timeout value for SYNC/CAL pulse detection.

If a SYNC/CAL pulse is not detected within the specified time, all Fast CH and Slow CH data are set to zero.

Measurable range: 0.1 ms to 2000.0 ms. The default setting is 2000.0 ms.

Resolution: 0.1 ms

SENT Data Extraction Conditions (All Sub Channel Setup)

Set the extraction conditions for each data type.

SENT Data Acquisition Destination

SENT data is extracted and acquired in each sub channel. The types of data acquired in sub channels are as follows.

- **Fast Channel Multiplexing Is Set to OFF**

Sub Channel	Data Type
1: FastCH	FastCH
2: FastCH	FastCH
3: FastCH	FastCH
4: S&C	S&C (Status & Communication)
5: SlowCH	SlowCH
6: SlowCH	SlowCH
7: SlowCH	SlowCH
8: SlowCH	SlowCH
9: SlowCH	SlowCH
10: Error Trigger	Error Trigger
11: Error Count	Error Count

- **Fast Channel Multiplexing Is Set to ON**

Sub Channel	Data Type
1: FastCH	FastCH
2: FastCH	FastCH
3: FastCH	FastCH
4: S&C	S&C (Status & Communication)
5: SlowCH/FastCH	SlowCH or FastCH
6: SlowCH/FastCH	SlowCH or FastCH
7: SlowCH/FastCH	SlowCH or FastCH
8: SlowCH/FastCH	SlowCH or FastCH
9: SlowCH/FastCH	SlowCH or FastCH
10: Error Trigger	Error Trigger
11: Error Count	Error Count

Common Settings

Input (Input)

Set the input for data type Fast CH, S&C (Status & Communication), SlowCH, Error Trigger, and Error Count.

ON: The data is monitored.

OFF: The data is not monitored. Nor is it displayed.

Label (Label)

You can set the label for data type Fast CH, S&C (Status & Communication), SlowCH, Error Trigger, and Error Count. You can also set the label for bits 0 to 3 of S&C.

▶ [See here.](#)

Data Type FastCH Extraction Conditions

FC

Data from messages with the specified FC (frame control) is acquired in the acquisition memory. When **fast channel multiplexing** is set to ON, you can specify FC.

Selectable range: 0x00 to 0x0F

The default value is 0x00.

Endian

Select the method (endian) to use to store the data in the acquisition memory.

Big: Big endian

Little: Little endian

Start Bit

Set the data extraction start position in terms of the bit position (bit number) from the beginning of the data nibble. Set it in terms of the number of data nibbles N of Fast CH messages, explained earlier.

Selectable range: 0 to $(4 \times N) - 1$

The default values are 0 for sub channel 1:FastCH, 12 for 2:FastCH and 0 for 3:FastCH.

To set the start bit to the most significant bit of each data nibble, specify $4 \times (n1)$ where n is the data nibble number.

Bit Size

Set the number of data bits to extract. Data is extracted from the start bit towards the back of the data. Set it in terms of the number of data nibbles N of Fast CH messages, explained earlier.

Selectable range: 1 to $\{(4 \times N) - (\text{Start Bit value})\}$, except FastCH3 is up to 16

The default setting is 12 for all sub channel FastCH.



If the number of bits of 1:FastCH is set to 17 or higher, the memory area of 2:FastCH will be used. Therefore, to set the number of bits of 1:FastCH to 17 or higher, set the 2:FastCH input to OFF. To set 2:FastCH input to ON, set the number of bits of 1:FastCH to 16 or less.

Data Type FastCH Extraction Example

If Endian: Big, Start Bit: 0, Bit Size: 12

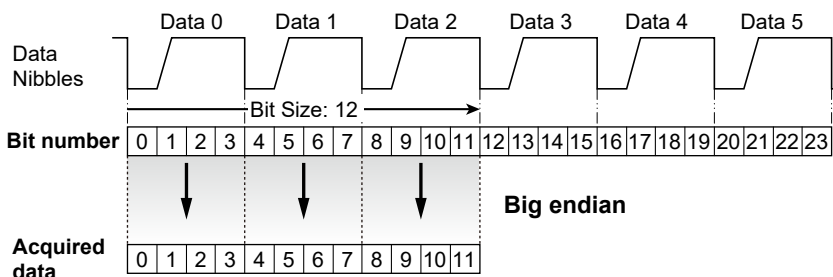

If Endian: Little, Start Bit: 0, Bit Size: 12

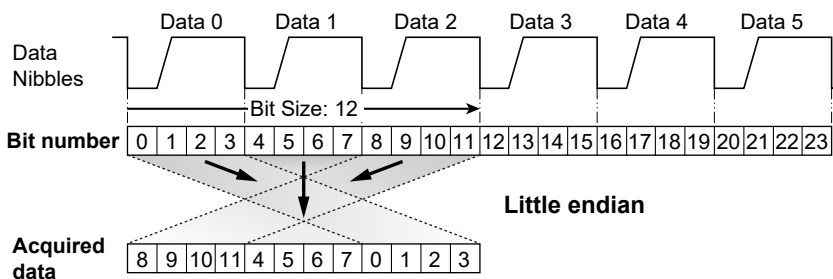

Value Type

Select the type of data to extract.

Unsigned: Unsigned integer

Signed: Signed integer

Data Type SlowCH Extraction Conditions**ID**

Data whose message ID matches the specified ID is acquired in acquisition memory. Configure the settings according to the Slow CH message format explained earlier.

Slow CH Message Format	Selectable Range
Short (ID 4bit + Data 8bit)	0x00 to 0x0F
Enhanced (ID 8bit + Data 12bit)	0x00 to 0xFF
Enhanced (ID 4bit + Data 16bit)	0x00 to 0x0F

The default value is 0x00.

Start Bit

Set the least significant bit position for starting extraction as a position (bit number) from the least significant bit of the data field. Configure the settings according to the Slow CH message format explained earlier.

Slow CH Message Format	Selectable Range
Short (ID 4bit + Data 8bit)	0 to 7
Enhanced (ID 8bit + Data 12bit)	0 to 11
Enhanced (ID 4bit + Data 16bit)	0 to 15

The default value is 0.

Bit Size

Set the number of data bits to extract. Data is extracted from the start bit towards the front of the data. Configure the settings according to the Slow CH message format explained earlier.

Slow CH Message Format	Selectable Range	Default Value
Short (ID 4bit + Data 8bit)	1 to {8-(Start Bit value)}	8
Enhanced (ID 8bit + Data 12bit)	1 to {12-(Start Bit value)}	12
Enhanced (ID 4bit + Data 16bit)	1 to {16-(Start Bit value)}	

Data Type SlowCH Extraction Example

If Slow CH message format: Short (ID 4bit + Data 8bit), Start Bit: 0, Bit Size: 8

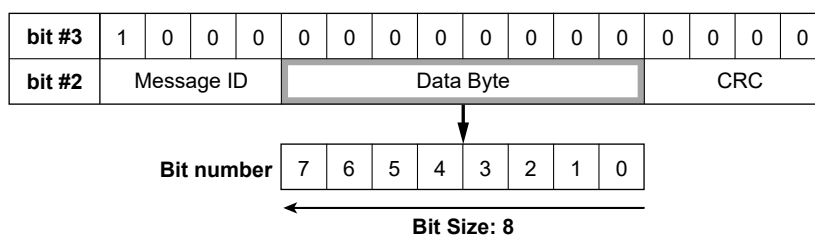

If Slow CH message format: Enhanced (ID 8bit + Data 12bit), Start Bit: 0, Bit Size: 12

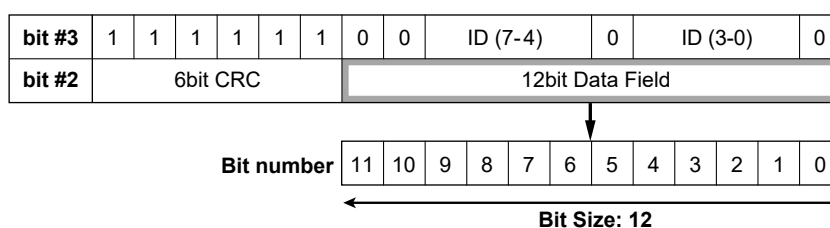

2 Channel Setup

If Slow CH message format: Enhanced (ID 4bit + Data 12bit), Start Bit: 0, Bit Size: 16

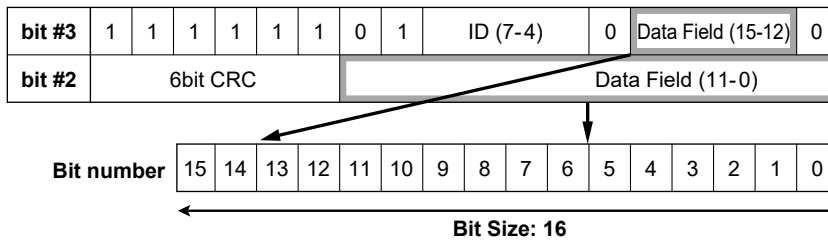

Value Type

Select the type of data to extract.

Unsigned: Unsigned integer

Signed: Signed integer

SENT Data Conversion Conditions (All Sub Channel Factor/Offset)

Set the conversion conditions for data type Fast CH and SlowCH.

Factor/Offset

The Factor and Offset values that you set here are used to convert the extracted data to physical values.

Factor: Scaling coefficient (value per bit)

Offset: Offset value

Selectable range: $-10.000E+30$ to $+10.000E+30$

Unit

Using up to 16 characters, enter the unit to display for the waveform.

SENT Data Display Settings (Sub Channel)

Sub channel 1: FastCH to 11: Error Count (Sub Channel 1: FastCH to 11: Error Count)

Configure the label, zoom magnification, scaling method, display range, and assignment to a display group of the specified sub channel.

For the association of each sub channel and the data type, see “[SENT Data Acquisition Destination.](#)”

Zooming by Setting a Magnification (V Zoom)

Configure this setting when the data type is set to S&C (Status & Communication) and Error Trigger.

Selectable range: x0.1 to x3.33

▶ [See here.](#)

Auto Scale and Default Scale (Auto Scale/Default Scale)

Configure this setting when the data type is set to Fast CH, SlowCH, or Error Count.

Auto Scale: The upper and lower display range limits are set automatically.

Default Scale: To the greatest extent possible within the settable range, the maximum and minimum values are used to set the display range setting (which is explained below) of the specified sub channel.

Display Range (Upper/Lower)

Set the upper and lower limits of the waveform display range. Configure this setting when the data type is set to Fast CH, SlowCH, or Error Count.

Selectable range: $-30.000E+30$ to $+30.000E+30$

Assignments to Display Groups (Display)

▶ [See here.](#)

Displaying the Menu for Configuring All Channels (ALL CH)

You can configure the settings of all channels while viewing the settings in a setup dialog box. You can also copy the various vertical axis settings of one channel to another channel. Note that there are some items that cannot be configured from the ALL CH menu.

Channel (Channel)

On the setup dialog box, you can turn the individual waveform inputs (Input) of each channel on and off. You can also turn on and off all installed modules at once using the following setting.

- All ON (All ON): The waveform inputs of all channels with modules installed are turned on.
- All OFF (All OFF): The waveform inputs of all channels are turned off.

Input Setup (Setup)

Measurement Items	Setting
Voltage	Waveform color, waveform input (Input) ON/OFF, label (Label), coupling (Coupling), vertical scale (V/div, ¹ Full Range ²), bandwidth limit (Band Width), probe attenuation ratio or current-to-voltage conversion ratio (Probe)
Temperature	Waveform color, waveform input (Input) ON/OFF, label (Label), coupling (Coupling), thermocouple type (Type), then with limit (Band Width), burnout (Burn Out), reference junction compensation (RJC)
Temperature (for the 16-CH Temperature/Voltage Input Module)	Waveform color, waveform input (Input) ON/OFF, label (Label), coupling (Coupling), vertical scale (V/div, ¹ Full Range ²), ³ thermocouple type (Type), ⁴ burnout (Burn Out), ⁴ reference junction compensation (RJC) ⁴
Strain	Waveform color, waveform input (Input) ON/OFF, label (Label), range unit (Range Unit), measurement range (Range), bandwidth limit (Band Width), bridge voltage (Excitation), gauge factor (Gauge Factor)
Acceleration	Waveform color, waveform input (Input) ON/OFF, label (Label), coupling (Coupling), gain (Gain), bandwidth limit (Band Width), sensitivity (Sensitivity)
Frequency	Waveform color, waveform input (Input) ON/OFF, label (Label), measured item (Function), vertical scale (V Scale), center frequency (Center Freq), ⁵ input settings (Input)
Logic	Waveform color, waveform input (Input) ON/OFF, label (Label), bit display (Bit Display), chatter elimination (Chatter Elim.), bit mapping (Mapping)

For channels that correspond to CAN bus monitor modules, CAN/CAN FD monitor modules, CAN & LIN bus monitor modules, or SENT monitor modules, you can only set the waveform color and waveform Input ON/OFF (Input) in the setup menu for configuring all channels.

- 1 Scope mode only
- 2 Recorder mode only
- 3 Only when measuring voltage
- 4 Only when measuring temperature
- 5 Only when the measured item is power frequency (Power Freq)

2 Channel Setup

Display (Display)

Measurement Items	Setting
Voltage	Waveform color, waveform input ON/OFF (Input), label (Label), zoom method (DIV/Scale), ¹ offset (Offset), ¹ position (Position), ¹ magnification for zooming (V Zoom), ¹ display range limits for zooming (Upper/Lower), sample rate (Sample Rate), ^{1,2} sample interval (Sample Interval) ³
Temperature	Waveform color, waveform input ON/OFF (Input), label (Label), display range settings (Upper/Lower), sample rate (Sample Rate), ^{1,2} sample interval (Sample Interval) ³
Temperature (for the 16-CH Temperature/Voltage Input Module)	Waveform color, waveform input ON/OFF (Input), label (Label), zoom method (DIV/Scale), ^{1,4} offset (Offset), ^{1,4} position (Position), ^{1,4} magnification for zooming (V Zoom), ^{1,4} display range limits for zooming (Upper/Lower), sample rate (Sample Rate), ^{1,2} sample interval (Sample Interval) ³
Strain	Waveform color, waveform input ON/OFF (Input), label (Label), display range settings (Upper/Lower), sample rate (Sample Rate), ^{1,2} sample interval (Sample Interval) ³
Acceleration	Waveform color, waveform input ON/OFF (Input), label (Label), Zoom method (DIV/Scale), ¹ position (Position), ¹ magnification for zooming (V Zoom), ¹ display range limits for zooming (Upper/Lower), sample rate (Sample Rate), ^{1,2} sample interval (Sample Interval) ³
Frequency	Waveform color, waveform input ON/OFF (Disp), label (Label), zoom method (DIV/Scale), ¹ position (Position), ¹ magnification for zooming (V Zoom), ¹ display range limits for zooming (Upper/Lower), sample rate (Sample Rate), ^{1,2} sample interval (Sample Interval) ³
Logic	Waveform color, waveform input ON/OFF (Disp), label (Label), position (Position), magnification for zooming (V Zoom), sample rate (Sample Rate), ^{1,2} sample interval (Sample Interval) ³

For channels that correspond to CAN bus monitor modules, CAN/CAN FD monitor modules, CAN & LIN bus monitor modules, or SENT monitor modules, you can only set the waveform color and waveform Input ON/OFF (Input) in the setup menu for configuring all channels.

- 1 Scope mode only
- 2 When dual capture zone, you can set high-speed sampling and low-speed sampling.
- 3 Recorder mode only
- 4 Only when measuring voltage

Linear Scaling (Linear Scale)

You can configure the linear scaling settings of all channels while viewing the settings in a list. This function is the same as the linear scaling function for voltage measurement.

Linear scaling (Linear Scale), AX+B:A P1-P2 P1:X, AX+B:B P1-P2 P1:Y, P1-P2 P2:X, P1-P2 P2:Y, unit string (Unit), display mode (Disp Type), number of decimal places (Decim Num), unit prefix (Sub Unit)

▶ [See here.](#)



The 701271 Strain Module (STRAIN_DSUB) supports [shunt calibration](#).

Real Time Math (RealTime Math) (/G03, /G05 option)

You can specify the following real time math channel items.

Waveform color, waveform input (Input) ON/OFF, label (Label), math operation (Operation), math source waveforms (Source)*

* Varies depending on the math operation.

▶ [See here.](#)

Copy (Copy to)

You can copy the various vertical axis and linear scaling settings from one channel to other channels whose modules are of the same type as the source channel.

Source Channel (Source)

Set the source channel to a channel from CH1 to CH16 or 16chTEMP/VOLT.*

* When a 16-CH Temperature/Voltage Input Module is installed. Select 16chTEMP/VOLT and then a sub channel.

Destination Channel (Destination)

Set the destination channel to ALL ON, ALL OFF, or a channel from CH1 to CH16.

Execute (Execute)

Select Execute to copy the settings.



- When a 16-CH Temperature/Voltage Input Module is installed, you can also copy the settings of the sub channels. You can specify only channels as copy destinations.
- The waveform display color and label settings are not copied.

Strain Balance and DC Offset Cancellation (Balance & DC Offset Cancel)

You can execute strain balancing and DC offset cancellation on multiple installed strain modules and voltage modules at once.

CH1 to CH16

Select the modules that you want to perform strain balancing or DC offset cancellation on.

Execute (Execute)

Execute strain balancing and DC offset cancellation.

For information about strain balancing, see the section on strain measurement.

▶ [See here.](#)



You cannot select channels in which strain modules are not installed.

Digital Filter (Filter)(/G03, /G05 option)

You can set digital filters on input channel waveforms (A/D converted data). This is one of the features of the /G3 and /G05 option. The other feature is [real time math](#).

- This is set on each channel. You can perform filtering on up to 16 channels at the same time.
- Even during waveform acquisition, you can change the filter type, filter band, and cutoff frequency.
- You cannot set digital filters on the bits or input channels of a logic, 16-CH voltage/temperature input, CAN bus monitor, CAN/CAN FD monitor, CAN & LIN bus monitor, SENT monitor, and 4-CH modules.
- By setting the waveform that results from filtering as a trigger source, you can trigger the instrument on the results.
- For details on the digital filter characteristics, delay, and settings, see appendix 11.

Bandwidth Limit (Bandwidth)

Selects the filtering feature. The feature is executed as soon as you select it.

- Digital (Digital): Select this item to display a menu for configuring the optional digital filter.
- LPF: Select this item to display a menu for configuring the standard filter.

▶ [See here.](#)

2 Channel Setup

Filter Type (Filter Type)

The following digital filter types are available: Gauss, Sharp, IIR, Mean (moving average), IIR-Lowpass. The features of each filter are listed below.

Filter Type	Features	Operation Type
Gauss	<ul style="list-style-type: none">• Frequency characteristics with a smooth attenuation slope• Linear phase and constant group delay• No ripples present in the passband• No overshoot in the step response• Low order and short delay	FIR
Sharp	<ul style="list-style-type: none">• Frequency characteristics with a sharp attenuation slope (40 dB at 1 oct)• Linear phase and constant group delay• Ripples present in the passband• Comb-shaped stopband	FIR
IIR	<ul style="list-style-type: none">• Attenuation slope steepness between those of the Sharp and Gauss filters• Non-linear phase and non-constant group delay• No ripples present in the passband and stopband• Characteristics similar to those of analog filters• Compared to Sharp and Gauss filters, lower cutoff frequency possible	IIR
Mean (moving average)	<ul style="list-style-type: none">• Comb-shaped frequency characteristics• Linear phase and constant group delay• No overshoot in the step response	FIR
IIR-Lowpass	<ul style="list-style-type: none">• Computes at 10 MS/s regardless of the setting.	IIR

Filter Band (Filter Band)

When the filter type is set to Gauss, Sharp, or IIR, you can select the filter band. The type of filter band that you can select depends on the filter type.

Filter Type	Filter Band
Gauss	Low-Pass*
Sharp	Low-Pass, High-Pass,* Band-Pass*
IIR	Low-Pass, High-Pass, Band-Pass

* Low-Pass: low-pass filter, High-Pass: high-pass filter, Band-Pass: bandpass filter

Cutoff Frequency (CutOff)

When the filter type is Sharp, Gauss, or IIR and the filter band is set to Low-Pass or High-Pass or when the filter type is IIR-Lowpass, set the cutoff frequency. The ranges and resolutions are indicated below.

Filter Type	Filter Band	Selectable Range	Resolution
Gauss	Low-Pass	0.002 kHz to 300 kHz Default value: 300 kHz	0.0002 kHz (0.002 kHz to 0.0298 kHz range)
			0.002 kHz (0.03 kHz to 0.298 kHz range)
			0.02 kHz (0.30 kHz to 2.98 kHz range)
			0.2 kHz (3.0 kHz to 29.8 kHz range)
Sharp	Low-Pass	0.002 kHz to 300 kHz Default value: 300 kHz	0.0002 kHz (0.002 kHz to 0.0298 kHz range)
			0.002 kHz (0.03 kHz to 0.298 kHz range)
			0.02 kHz (0.30 kHz to 2.98 kHz range)
			0.2 kHz (3.0 kHz to 29.8 kHz range)
	High-Pass	0.20 kHz to 300 kHz Default value: 300 kHz	0.02 kHz (0.20 kHz to 2.98 kHz range)
			0.2 kHz (3.0 kHz to 29.8 kHz range)
			2 kHz (30 kHz to 300 kHz range)
			—
IIR	Low-Pass	0.002 kHz to 300 kHz Default value: 300 kHz	0.002 kHz (0.002 kHz to 0.298 kHz range)
			0.02 kHz (0.30 kHz to 2.98 kHz range)
			0.2 kHz (3.0 kHz to 29.8 kHz range)
			2 kHz (30 kHz to 300 kHz range)
	High-Pass	0.02 kHz to 300 kHz Default value: 300 kHz	0.02 kHz (0.02 kHz to 2.98 kHz range)
			0.2 kHz (3.0 kHz to 29.8 kHz range)
			2 kHz (30 kHz to 300 kHz range)
			—
IIR-Lowpass	Low-Pass	128 kHz, 64 kHz, 32 kHz, 16 kHz, 8 kHz, 4 kHz, 2 kHz, 1 kHz, 500 Hz, 250 Hz, 125 Hz, 62.5 Hz Default value: 128 kHz	—

Center Frequency (Center Frequency)

When the filter type is set to Sharp or IIR and the filter band is set to Band-Pass, set the center frequency. The ranges and resolutions are indicated below.

Filter Type	Selectable Range	Resolution
Sharp	0.30 kHz to 300 kHz Default value: 300 Hz	0.02 kHz (0.30 kHz to 2.98 kHz range)
		0.2 kHz (3 kHz to 29.8 kHz range)
		2 kHz (30 kHz to 300 kHz range)
IIR	0.06 kHz to 300 kHz Default value: 300 Hz	0.02 kHz (60 Hz to 1.18 kHz range)
		0.2 kHz (1.2 kHz to 11.8 kHz range)
		2 kHz (12 kHz to 300 kHz range)

Bandwidth (Pass Band)

When the filter type is set to Sharp or IIR and the filter band is set to Band-Pass, set the bandwidth. The bandwidth options vary depending on the center frequency that you have set. For details about these options, see the appendix.

Tap (Tap)

When the filter type is set to Mean (moving average), select the number of taps (number of levels) from the following options. The larger the number of taps, the sharper the filter characteristics become.

2, 4, 8, 16, 32, 64, 128

Moving Average Sample Rate (Mean Sample)

When the filter type is set to Mean (moving average), select the sample rate from the following options. The selected rate is used to sample waveforms and to filter them.

1 M, 100 k, 10 k, 1 k (unit: S/s)

2 Channel Setup

Interpolation On and Off (Interpolate)

Select whether to perform data interpolation when the filter type is Gauss, Sharp, IIR, or Mean (moving average).
Waveform data after passing through the digital filter can be interpolated up to 10 M using the CIC filter.

- ON: Data is interpolated.
- OFF: Data is not interpolated.

3 Waveform Acquisition

Based on the data that has been stored in the acquisition memory, the instrument performs various operations, such as displaying waveforms on the screen, computing, measuring cursors, and automatically measuring waveform parameters.

This chapter explains how to set the number of data points to store in the acquisition memory (the record length), how to enable or disable the sample data averaging feature, and so on.

Operation Modes and Settings

The settings vary depending on the operation mode as follows:

Settings in Scope Mode

When Dual Capture Is Off

- [Time Scale \(TIME/DIV knob\)](#)
- [Record Length \(Record Length\)](#)
- [Acquisition Mode \(Acquisition Mode\)](#)
- [Trigger Mode \(Trigger Mode\)](#)
- [Acquisition Count \(Acquisition Count\)](#)
- [SSD Recording \(SSD Recording\)](#)
- [Time Base \(Time Base\)](#)

When Dual Capture Is On

- [Dual Capture ON/OFF \(DualCapture\)](#)
- [Low-speed Sampling \(Low Speed Sample\)](#)
- [High-speed Sampling \(High Speed Setting\)](#)
- [Capture Mode \(Capture Mode\)](#)
- [Action \(Action\)](#)
- [Action Setup \(Setup\)](#)

Settings in Recorder Mode

Basic Setup

- [Acquisition Time, Record Time, Record Length \(Acquisition Time, Record Time, Record Length\)](#)
- [Sample Interval \(Sample Interval\)](#)
- [Acquisition Condition \(Acquisition Condition\)](#)
- [Acquisition Method \(Acquisition Method\)](#)

Detail setup

- [Detailed Acquisition Method Settings](#)
- [Acquisition Mode \(Acquisition Mode\)](#)
- [Time Base \(Time Base\)](#)

Time Scale (TIME/DIV knob)

This is a setting available in Scope mode.

When the internal clock is being used, the time scale is set as a length of time per grid division (1 div). The selectable ranges are 100 ns/div* to 30 s/div, 1 min/div to 30 min/div, 1 hour/div to 12 hour/div, 1 day/div to 5 day/div. The transition from seconds to minutes to hours to days occurs automatically. Because the horizontal display range is 10 div, the amount of time on the waveform that is displayed is equal to the time scale \times 10.

* It varies depending on the module's maximum sample rate. For the selectable time scale range, see appendix 2, "Relationship between the Time Scale, Record Length, and Sample Rate" in the *Getting Started Guide*, IM DL950-03EN.

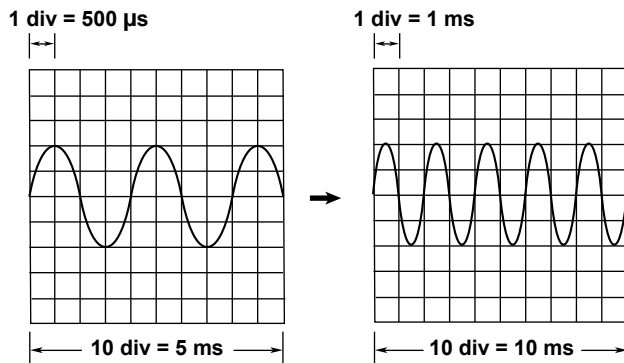

Internal and External Clocks (Time base selection)

By default, the instrument samples the waveform data using the clock signal produced by its internal time-base circuit (internal clock).

You can also use an external clock signal to control sampling. Apply the external clock signal to the external clock input terminal on the left panel of the instrument. This external clock input is useful for synchronizing to the clock signal of the waveform that is being measured.



When you control sampling using an external clock, you cannot change the time scale. To change the time-axis display range, change the record length, or zoom in on the time axis.

► [See here.](#)

How the Time Axis Relates to the Display of the Waveform

There are 10 divisions along the time axis, and 1001 points (logical number of points, not the dots on the screen) are used to draw the waveforms. Therefore, when the display record length is 1 kpoint (the number of acquired data points is 1001), the waveform is drawn using 1001 points. However, if the display record length is greater than or equal to 2 kpoint, as shown in the figure on the right, the instrument draws the waveform by determining the maximum and minimum values at each fixed interval (P-P compression) and aligning them vertically at the same time position (the total number of points is 2001 as the right edge is one point).

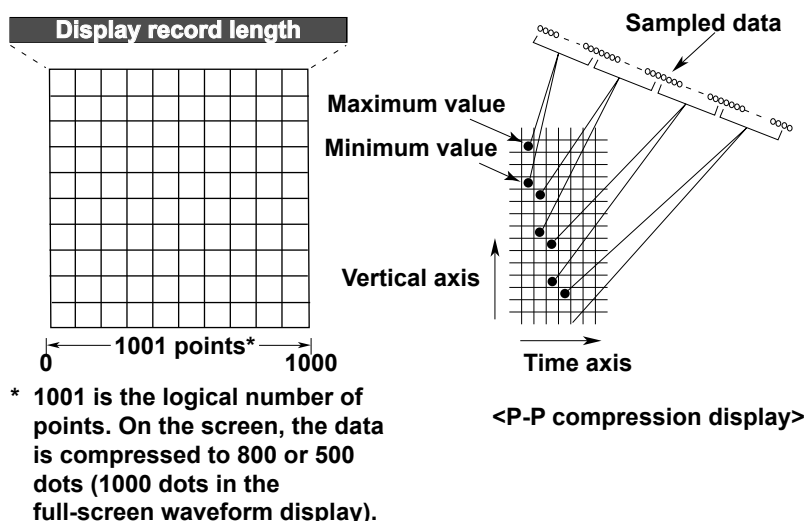

Zooming Horizontally and Drawing Waveforms

The instrument can expand (zoom) the waveform horizontally. When the zoom factor of the waveform is increased, the number of displayed points decreases. The instrument displays the waveform by applying P-P compression until the number of displayed points falls to 2001, but it cannot display the waveform using continuous lines when the number of displayed points falls below 1001. When this happens, the instrument [interpolates the display data](#) so that the number of displayed points is 1001.

Dot Display

By default, display interpolation is performed automatically, but you can also disable it (set it to OFF) and display the waveform using dots. With this setting, up to 2 kpoint or 100 kpoint of all the acquired data are displayed without P-P compression. For example, if the number of displayed points is set to 100 kpoint and the display record length is 10 kpoint (the number of acquired data points is 10001 points), the instrument draws all the points of the waveform by aligning 10 points (the right edge is one point) vertically at the same time axis position. If the number of acquired data points is greater than or equal to the specified number of sample points (2 kpoint or 100 kpoint), the instrument displays only the data per given interval. In other words, the instrument samples the data during the interval and display the waveform with 2 kpoint or 100 kpoint.

Relationship between the Time Scale, Sample Rate, and Record Length

When you change the time scale, the sample rate for the set record length and the actual number of data points acquired to the acquisition memory (display record length) change. For details, see appendix 2, "Relationship between the Time Scale, Record Length, and Sample Rate" in the *Getting Started Guide*, IM DL950-03EN.

3 Waveform Acquisition

Sample Rate

When you change the time scale, the sample rate for the set record length changes. The sample rate is the number of samples-per-second (S/s).

- * If the sample rate is comparatively low with respect to the input signal frequency, the harmonics contained in the signal are lost. When this happens, some of the harmonics will be misread as low-frequency waves due to the effects described by the Nyquist sampling theorem. This phenomenon is called aliasing. You can avoid aliasing by acquiring waveforms with the acquisition mode set to Envelope.

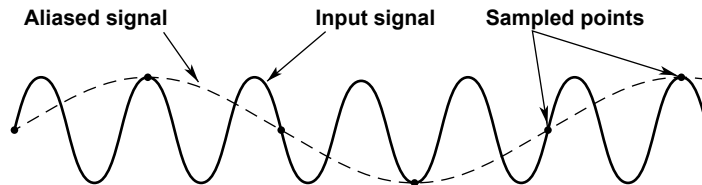

Time Scale and Roll Mode Display

When the trigger mode is Auto, Auto Level, Single, or On Start and the time scale is 100 ms/div or longer, instead of updating waveforms through triggering (update mode), the instrument displays the waveforms in roll mode. In roll mode, waveforms scroll from right to left as new data is captured and the oldest values are cleared from the screen.

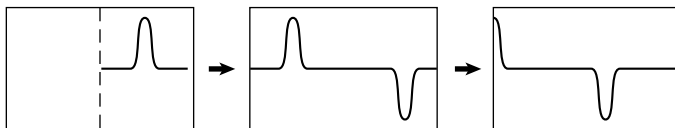

This allows waveforms to be observed in the same way as on a pen recorder. Roll mode is useful for observing signals with long repeating periods and signals that change slowly. It is also effective when you want to detect occasional glitches (pulse signals in the waveform).



You can use auto setup to automatically configure the appropriate settings (such as vertical axis, horizontal axis, and trigger settings) for the input signal. This feature is useful when you are not sure what type of signal will be applied to the instrument. The auto setup feature will not work properly on some input signals. Also, there are some modules with which the auto setup feature cannot be used. ► [See here.](#)

Notes about Using the 16-CH Temperature/Voltage Input Module (720221)

► [See here.](#)

Record length (Record Length)

This is a setting for Scope mode and when timebase is set to external clock in Recorder mode. Set the number of data points per waveform (record length) to acquire when acquiring data.

When the Time Base Is Set to Internal Clock (Scope mode)

The record length set on the ACQUIRE menu is referred to as the *set record length*. The acquisition memory is divided into compartments by the set record length, and waveforms are acquired in those compartments.

Display record length refers to the number of waveform data points that are actually stored to the acquisition memory.

The set record length and display record length are basically the same, but the display record length may be shorter depending on the time scale. The combination of the set record length and time scale determines the sample rate and display record length.

Use a long time scale when you want to observe a phenomenon over a long period of time. When you want to observe a phenomenon at a high time resolution, set a long record length, and raise the sample rate. When the record length is long, computation and measurement processing take longer than when the record length is short.

The following tables show the duration of time data can be acquired to the acquisition memory.

When the Set Record Length Is 500 Mpoint

Sample Rate	In Seconds	In Minutes	In Hours	In Days
200 MS/s	2	0.033	0.00056	0.000023
100 MS/s	5	0.083	0.0014	0.000058
10 MS/s	50	0.83	0.014	0.00058
1 MS/s	300	5	0.083	0.0035
100 kS/s	3600	60	1	0.042
10 kS/s	36000	600	10	0.42
1 kS/s	432000	7200	120	5
500 S/s	864000	14400	240	10

When the Set Record Length Is 4 Gpoint (/M2 option)

Sample Rate	In Seconds	In Minutes	In Hours	In Days
200 MS/s	20	0.33	0.0056	0.00023
100 MS/s	40	0.67	0.011	0.00046
10 MS/s	300	5	0.083	0.0035
1 MS/s	3600	60	1	0.042
100 kS/s	36000	600	10	0.42
10 kS/s	360000	6000	100	4.2
1 kS/s	3456000	57600	960	40
500 S/s	4320000	72000	1200	50

When the Time Base Is Set to External Clock (Scope mode, Recorder mode)

The data is sampled at the external clock input interval, and the record length of waveform data is acquired to the acquisition memory. The time scale setting is not available in Scope mode. The sampling interval and acquisition time/recording time settings are not available in Recorder mode.



Notes about Setting the Record Length

- The record length that can be specified varies depending on the memory size. When dual capture is off, the maximum record length is 500 Mpoint on the standard model, 2 Gpoint on models with the /M1 option, 4 Gpoint on models with the /M2 option, or 20 Gpoint on models with the /ST1 option during SSD recording (when the memory is the standard model).
In addition, the record length that can be specified varies depending on the number of channels in use. If the record length that can be specified is exceeded when a channel input setting is turned on, the record length is automatically changed to the maximum value allowed. For details on the record length and the maximum number of channels, see appendix 4 in the *Getting Started Guide*, IM DL950-03EN.
 - There is a limit to the number of waveforms that can be stored in the acquisition memory (the number of history waveforms) depending on the specified record length. ► [See here](#).
 - In the following cases, there is a limit to the set record length that allows waveform acquisition. For details, see appendix 5 in the *Getting Started Guide*, IM DL950-03EN.
 - When the acquisition mode is set to averaging
 - When the trigger mode is Normal or Single N or when the trigger mode is Auto or Auto Level and roll mode display is not in use.
 - On the instrument, record lengths are expressed in units of points.
-

Acquisition Mode (Acquisition Mode)

Select from the following. Averaging mode is not available in Recorder mode.

Normal Mode (Normal)

The instrument displays waveforms without processing the sampled data.

Envelope Mode (Envelope)

The instrument determines the maximum and minimum values among the data sampled at the maximum sample rate for each input module at a time interval that is twice the sampling period (the inverse of the sample rate) of Normal mode, saves the values as pairs in the acquisition memory, and uses the saved value pairs to display the waveforms. This mode is effective when you want to avoid aliasing, because the sample rate is essentially kept high regardless of the time scale. It is also effective when you want to detect glitches (narrow pulse signals) or when you want to display the envelope of a modulated signal.

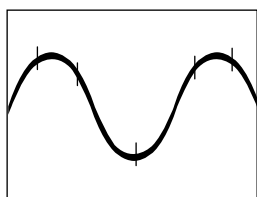

Normal mode

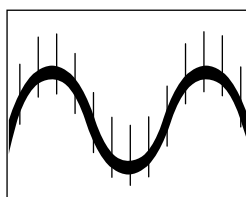

Envelope mode



When dual capture is on, envelope waveforms can be displayed only for low-speed sampling waveforms.

Averaging Mode (Average)

This is a setting available in Scope mode. The instrument acquires waveforms multiple times, averages the same time points relative to the trigger point, saves them in the acquisition memory, and uses them to display averaged waveforms. Averaging mode is useful when you want to remove random noise from waveforms.

Attenuation Constant (Weight)

Selectable range: 2 to 256 in 2^n steps

The averaging method varies depending on the acquisition count.

When Acquisition Count Is Set to Infinity

Exponential average

$$A_n = \frac{1}{N} \{(N-1)A_{n-1} + X_n\}$$

A_n : n^{th} averaged value

X_n : n^{th} measured value

N : Attenuation constant
(2 to 256 in 2^n steps)

When Acquisition Count Is Set to a Value between 2 and 65536 (in 2^n steps)

Linear average

$$A_N = \frac{\sum_{n=1}^N X_n}{N}$$

X_n : n^{th} measured value

N : Average count = acquisition count



- When waveforms are acquired in averaging mode, they are saved to the acquisition memory as a single record. This means that the history feature cannot be used.
- You cannot select averaging mode when:
 - The display is in roll mode.
 - The trigger mode is Single, N Single, or On Start.
 - The dual capture feature is enabled.
 - SSD recording is being executed.
- To average waveforms that have been acquired with the trigger mode set to N Single, set the acquisition mode to Normal, and turn on the history feature's display mode to average waveform.
- Waveforms of logic, CAN bus monitor, LIN bus monitor, or SENT monitor modules cannot be averaged.

Trigger Mode (Trigger Mode)

This is a setting available in Scope mode.

When dual capture is on, the trigger mode (high-speed sampling) is fixed to Normal.

The trigger mode determines the conditions for updating the displayed waveforms. The following six trigger modes are available.

Auto Mode (Auto)

If the trigger conditions are met before an approximately 50 ms timeout, this instrument updates the displayed waveforms on each trigger occurrence. If not, this instrument automatically updates the displayed waveforms. If simple trigger is in use and the trigger source is set to Time, the instrument operates in Normal mode even when Auto mode is specified. If the time axis is set to a value that would cause the display to switch to roll mode, roll mode display will be enabled.

Auto Level Mode (AutoLevel)

If a trigger occurs before a timeout (which is approximately 1 second), the instrument updates the waveform in the same way that it does in Auto mode. If a trigger does not occur before a timeout, the instrument automatically changes the trigger level to the center value of the trigger source amplitude, triggers on that value, and updates the displayed waveform. Auto Level mode is valid only if the trigger source is an analog waveform received through CH1 to CH16 (sub channels included, real time math waveforms excluded). For all other cases, Auto Level mode operates in the same way as Auto mode. If the time axis is set to a value that would cause the display to switch to roll mode, roll mode display will be enabled.

Normal Mode (Normal)

The instrument updates the waveform display only when the trigger conditions are met. If no triggers occur, the display is not updated. If you want to view waveforms that the instrument cannot trigger on or if you want to check the ground level, use Auto mode.

Single Mode (Single)

When the trigger conditions are met, the instrument updates the displayed waveform once and stops acquiring signals. If the time axis is set to a value that would cause the display to switch to roll mode, roll mode display will be enabled. When the instrument triggers, it begins recording data. When data has been acquired up to the amount specified by the set record length, the waveform display stops.

N Single Mode (Single N)

The instrument acquires signals each time the trigger conditions are met until a specified number of signals have been acquired, stops acquisition, and displays all of the acquired signals. Since the waveform display is not updated until the set number of triggers are established, the dead time required to update the display can be reduced compared to Normal mode in which the waveform display is updated each time the trigger is established. If no triggers occur, the display is not updated.

Instant Start Mode (On Start)

Regardless of the trigger settings, when you press the START key, the instrument updates the displayed waveforms once and stops acquiring signals.

If the time axis is set to a value that would cause the display to switch to roll mode, roll mode display will be enabled. When data has been acquired up to the amount specified by the set record length, the waveform display stops.



-
- The trigger mode setting applies to all trigger types.
 - When waveforms are being acquired, the trigger condition appears in the lower right of the screen.
-

N Single Mode (Single N)

Set the waveform acquisition count for when the trigger mode is set to Single N.

Selectable range: 1 to 5000 in steps of 1

Acquisition Count (Acquisition Count)

Set the measurement count (waveform acquisition count) for when the trigger mode is not set to Single N in the following range. If you select Infinite, the instrument continues to acquire waveforms until you stop it using the START/STOP key. The default setting is Infinite. Changes made to the number of acquisitions are not applied during waveform acquisition. They are applied after acquisition stops.

- When the acquisition mode is set to Normal or Envelope
1 to 65536 (in steps of 1) or Infinite
- When the acquisition mode is set to Average
2 to 65536 (in 2ⁿ steps) or Infinite



- The number of waveforms that have been stored to the acquisition memory appears in the lower left of the screen.
- If the trigger mode is set to Single or On Start, you can set the acquisition count only when the action mode is on. ► [See here.](#)
- If date folder creation (Create Date Folder) ► [See here.](#) in the action settings is set to OFF, the maximum measurement count that you can specify is 1000.

SSD Recording (SSD recording, /ST1 option)

This is an option available in Scope mode when dual capture is off.

Set whether to acquire waveforms in SSD recording.

SSD recording is possible when dual capture is on (► [See here.](#)) and when Recording mode is in use (► [See here.](#)).

OFF

SSD recording is not performed.

ON

Data is recorded in sync with the start of a measurement to the SSD (/ST1 option), an internal storage space in the instrument. The recorded data is saved to files automatically. You can load the data that has been saved.

SSD recording

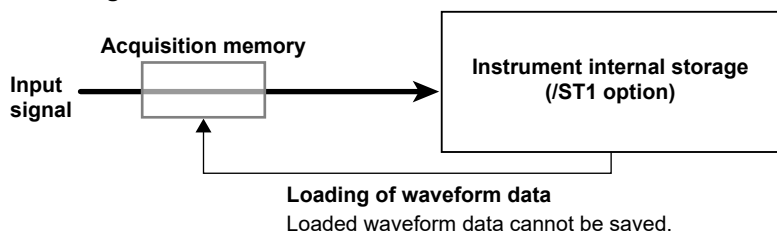

Normal measurement

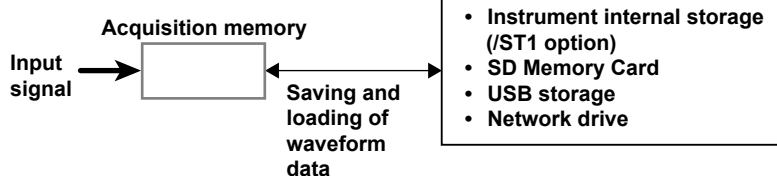

Scope Mode

- During SSD recording, the trigger mode is set to On Start. The instrument records data for the specified measurement time (time scale×10) and then stops acquiring waveforms. The maximum record length is 50 days.
- SSD recording is possible when the record length is 1 Mpoint or more and the time scale is 100 ms/div or more (roll mode display region). For details, see appendix 2 in the *Getting Started Guide*, IM DL950-03EN. For details on the set record length and maximum number of channels, see appendix 4 in the *Getting Started Guide*.

Recorder Mode

- During SSD recording, the acquisition condition is set to Record Time. The instrument records data for the specified record time and then stops acquiring waveforms. The maximum record length is 50 days.
- For the acquisition time, sampling interval, and maximum number of channels that SSD recording is allowed, see appendix 8 in the *Getting Started Guide*.

Relationship between the Number of Channels That SSD Recording Is Allowed and Sample Rate

Number of Channels That SSD Recording Is Allowed	Maximum Sample Rate
1	2 MS/s
3	1 MS/s
6	500 kS/s
16	200 kS/s
32	100 kS/s
64	50 kS/s

- In Scope mode, even when the set record length and time scale are set properly (see appendix 2 in the *Getting Started Guide*), the maximum sample rate is limited depending on the number of channels in use as shown above.
- If the time base is set to external in Record mode, the external clock input frequency that SSD recording is allowed is up to the maximum sample rate shown above.
- For details, see appendix 6 in the *Getting Started Guide*.

SSD Recording Setup (SSD Recording Setup)

Set the names of the data files saved in SSD recording and other items.

In SSD recording, a date folder (folder with a year, month, and day in its name)* is created in the internal storage, and the recorded data file is saved in that folder.

* In multi-unit synchronization mode (/C50 option), a fixed area (REMOTE) is created in the internal storage, and a date_time folder is created in it.

- **Auto Naming (Auto Naming), File Name (File Name), Comment (Comment)**

The auto naming feature automatically assigns the file names. You can set the auto naming method to serial numbers or dates. You can also set comments.

▶ [See here](#).

- **File Division (File Divide)**

You can specify the number of files that the recorded data is divided into. You can use this feature to avoid creating large files that take time to process. You can select the number of divisions (Number), but the actual number of files that will actually be saved is a number close to the specified number.



- SSD recording cannot be performed when the action mode is on.
 - When SSD recording is performed in Scope mode, the time base cannot be set to external clock in Scope mode.
 - Math waveforms cannot be displayed when SSD recording is in progress.
 - You can perform the following operations on data that has been recorded to the SSD: cursor measurement, automated measurement of waveform parameters (up to 100 Mpoint), waveform zooming. You cannot use the history feature.
 - During SSD recording, the instrument may respond more slowly to operations.
 - The maximum number of files that can be saved to a single folder is 1000. If the number of files in the save destination folder exceeds 1000, a new folder is automatically created with the date and an incremented sequence number (000 to 999) as its name, and the data continues to be saved in the new folder.
 - Do not store more than 513 files in the root directory of the internal storage. Doing so will slow the file access operations to all files. In addition, we cannot guarantee the SSD recording operation when the instrument is in this condition.
 - Do not connect a USB storage device to the instrument during SSD recording or before you start SSD recording.
-

Time Base (Time Base)

By default, the instrument samples the measured signals using the clock signal produced by its internal time-base circuit (internal clock). You can also use an external clock signal to control sampling. One data sample is stored to the acquisition memory at every pulse in the external clock signal. The external clock input is useful when you want to monitor the waveform using a clock signal that is in sync with the signal being measured. Apply the external clock signal to the external-clock input terminal (EXT CLK IN) on the left panel. For the specifications of the external-clock input terminal, see the *Getting Started Guide*, IM DL950-03EN.

Internal	The internal clock signal is used for the time base (the TIME/DIV setting is valid).
External	An external clock signal is used for the time base (the TIME/DIV setting is invalid).

Pulses per Rotation (Pulse/Rotate)

When the time base is an external clock, you can specify how many pulses of the external clock signal (how many sampled data acquisitions) correspond to one mechanical rotation (or period). For example, if you set Pulse/Rotate to 1000 pulses, when the set record length is 10 kpoint, 10 rotations worth of sampled data will be acquired. When Pulse/Rotate is set to 1 pulse, each point of sampled data corresponds to a single rotation. The Pulse/Rotate setting only affects the horizontal-cursor measurement values and how the time axis is displayed on the screen. For example, if you set Pulse/Rotate to 1000 pulses, when the set record length is 1 kpoint, one division will correspond to 10 rotations. With these settings, if you move the cursor by one division, the measured horizontal value will increase or decrease by 1.

Selectable range for pulses: 1 to 24000

3 Waveform Acquisition



Notes about Sampling Using an External Clock Signal

- Roll mode display is not available in Scope mode.
- There is no function for dividing the frequency of the clock signal.
- The time axis cannot be changed. To change the time-axis display range, change the record length, or zoom in on the time axis.
- The measured time values in cursor measurements and automated measurements of waveform parameters indicate the number of clock signal pulses. For these measurements, units are not displayed.
- You cannot configure SSD recording in Scope mode.
- Dual capture cannot be executed.
- The trigger settings listed below are invalid.
Hold-off, trigger delay, period trigger, pulse width trigger

Maximum Sample Rates for Each Module

If you set the instrument's sample rate to a rate that is higher than a module's maximum sample rate, because the data is updated at the module's maximum sample rate, all the data within the module's data update interval will be the same. The maximum sample rates for each module are listed below.

Module	Maximum Sample Rate	
	Internal Clock	External Clock
720256/701250/720250/701255	10 MS/s	9.5 MS/s
701251	1 MS/s	1 MS/s
701270/701271/701275	100 kS/s	100 kS/s
720268	1 MS/s	1 MS/s
701261/701262	(when measuring voltage) 100 kS/s	100 kS/s
	(when measuring temperature) 500 S/s	500 S/s
701281/720281	1 MS/s	1 MS/s
701265	500 S/s	500 S/s
720266	125 kS/s	125 kS/s
720212	200 MS/s	9.5 MS/s
720211	100 MS/s	9.5 MS/s
720221	0.1 S/s	0.1 S/s
720230	10 MS/s	9.5 MS/s
720240/720241/720242/720243	100 kS/s	100 kS/s
720254	1 MS/s	1 MS/s

Notes about Using the 16-CH Temperature/Voltage Input Module (720221)

▶ [See here.](#)

Dual Capture (DUAL CAPTURE, Scope mode only)

Waveform data can be acquired at a high sampling rate (high-speed sampling) while acquiring waveform data of the low-speed roll mode display (low-speed sampling). This is useful when you want to capture fast phenomena at a high sampling rate while observing the waveform over long-term at a low sampling rate.

Waveform data acquired using dual capture can be saved as (1) binary data that includes both low-speed sampling and high-speed sampling, (2) binary, ASCII, or MATLAB data that includes high-speed sampling only, or (3) ASCII or MATLAB data that includes low-speed sampling only.

Low-speed sampling waveform
Roll mode display (up to 50 Gpoint*)

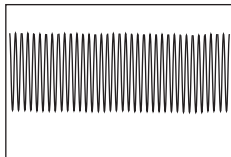

Sample rate:
100 kS/s or less

High-speed sampling waveform
Update mode display

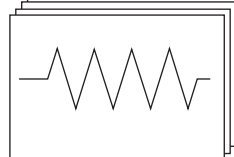

Sample rate:
Faster than that of the low-speed
sampling waveform

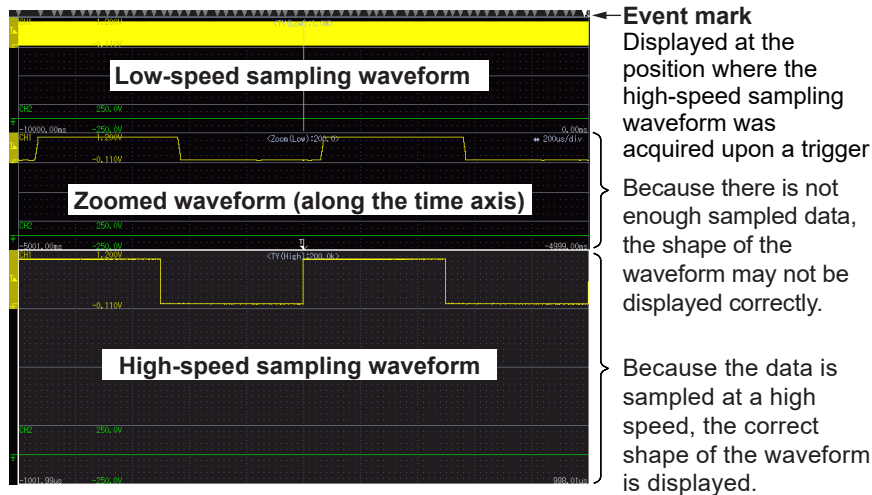

* On Models with the /ST1 Option

Dual Capture ON/OFF (DualCapture)

Enables or disables dual capture.

- ON: Dual capture is enabled.
- OFF: Dual capture is disabled.

Low-speed Sampling Settings (Low Speed Sample)

- Time scale (T/div): Set the time scale of the low-speed sampling waveform. Select from 1 s/div to 5 day/div. [▶ See here.](#)
- Record length (Record Length): Set the record length of the low-speed sampling waveform. Select from 1 M to 2 G, 4 G to 50 Gpoint.* [▶ See here.](#)
 - * SSD recording (/ST1 option)
- Acquisition mode (Acquisition Mode): Select Normal or Envelope. [▶ See here.](#)
- SSD recording (SSD Recording) (/ST1 option): Select the check box to turn on SSD recording and execute SSD recording only with low-speed sampling. SSD recording cannot be performed when the action is set to ON. [▶ See here.](#)
- SSD recording setup (Setup) (/ST1 option): If you select the SSD recording check box, set auto naming, file division, and so on. [▶ See here.](#)

3 Waveform Acquisition

High-speed Sampling Settings (High Speed Sample)

- Time scale (T/div): Set the time scale of the high-speed sampling waveform. Select from 100 ns/div* to 1 min/div. [▶ See here.](#)
 - * It varies depending on the module's maximum sample rate. 100 ns/div can be specified only on modules that are 100 MS/s or faster.
- Record length (Record Length): Set the record length of the high-speed sampling waveform. Select from 10 k to 50 Mpoint. [▶ See here.](#)



- The settings can be specified in the range that causes the high-speed sample rate to be faster than the low-speed sample rate. For details on the relationship between the time scale, record length, and sample rate, see appendix 2 in the *Getting Started Guide*, IM DL950-03EN.
- The high-speed sampling time scale (T/div) must be set shorter than the low-speed sampling time scale (T/div).
- High-speed sampling waveforms can be displayed on the screen by specifying display numbers with the history feature. For the high-speed sampling waveform acquisition count, see appendix 7 and the *Getting Started Guide*.

Trigger Conditions

- When the trigger conditions set with the trigger feature are met, the instrument triggers and acquires high-speed sampling waveforms.
- When automated measurement of waveform parameters is enabled, after high-speed waveforms are acquired, the time it takes for the instrument to enter the next trigger-weight state may be long.

Capture Mode (Capture Mode)

Select Auto or On Start. This is fixed to On Start during SSD recording.

Auto (Auto)	Low-speed sampling and high-speed sampling waveform acquisition continues from when waveform acquisition is started with the START/STOP key until it is stopped with the START/STOP key. For high-speed sampling waveforms, waveform acquisition continues even if the acquisition count is exceeded, and the most recent data (acquisition count worth) when acquisition is stopped is saved in the acquisition memory. For low-speed sampling waveforms, the most recent data (display record length worth) when acquisition is stopped is saved in the acquisition memory.
On Start (On Start)	After waveform acquisition is started with the START/STOP key, acquisition of low-speed sampling waveforms and high-speed sampling waveforms stops when low-speed sampling waveform's measurement time worth of data (time scale (T/div)×10) is acquired. However, if the high-speed sampling waveform's acquisition count is exceeded while low-speed sampling waveforms are being acquired, the acquisition of high-speed sampling waveforms stops.

Action (Action)

Selecting this check box enables the action feature. When waveform acquisition is finished or when high-speed sampling waveform is acquired due to a trigger, the instrument executes the preset action. The time when an action starts varies depending on the selected action as follows:

Action Type	When the Action Is Executed		
	When waveform acquisition is finished	When a high-speed sampling waveform is acquired	
Saving of waveform data	All binary data	Y	N
	Low-speed sampling only	Y	N
	High-speed sampling only	N	Y
Other actions	Y	Y	

Y: The action is executed. N: The action is not executed.



- The action feature cannot be enabled when SSD recording is enabled.
- When saved high-speed sampling waveform data is loaded in this instrument, the data can be resaved. However, high-speed sampling waveform data obtained in auto (Auto) mode with data existing in an area in which 10 divisions of low-speed sampling waveform data cannot be retained cannot be resaved if it is loaded.

Action Setup (Setup)

If you select the action check box, set the action type, save location, and so on.

▶ [See here.](#)



The following table shows the source waveforms for math, analysis, and measurement when dual capture is on. When the source is changed, the measured values are reset.

	High-speed sampling waveform	Low-speed sampling waveform
Math	Y	—
FFT	Y	—
X-Y	Y	—
Cursor measurement	Y ¹	Y ¹
Automated measurement of waveform parameters	Y	Y ²

Y: Source waveform

- 1 Either the high-speed sampling or low-speed sampling waveform can be specified.
- 2 When low-speed measurement mode is enabled, the low-speed sampling waveform can be specified.



- To enable dual capture, set the time base to internal clock. It cannot be enabled, if the time base is set to external clock.
- The accumulation feature cannot be used.
- When dual capture is in progress, the instrument may respond more slowly to operations.

Basic Recorder Mode Setup (Basic)

These are settings available in Recorder mode.

Acquisition Time, Record Time, Record Length (Acquisition Time, Record Time, Record Length)

When the **time base** is internal clock (Internal)

Data is acquired for the specified time.

- **When the acquisition method is memory (Memory), memory + save on stop (Memory + Save on Stop)**

The acquisition time (Acquisition Time) is displayed.

Selectable range:* 1 s to 50 day

- * When the acquisition condition is set to Continuous or Trigger, select the acquisition time from the available options shown on the menu.

- **When the acquisition method is SSD recording (SSD Recording)**

The record time (Record Time) is displayed.

Selectable range: 1 s to 50 day

When the **time base** is external clock (External)

The instrument acquires the specified record length of data. ▶ [See here.](#)

Sample Interval (Sample Interval)

The instrument acquires waveforms at the specified sample interval (time interval).

For details on the acquisition time, recording time, and sample interval, see appendixes 1 and 8 in the *Getting Started Guide*, IM DL950-03EN.

Acquisition Condition (Acquisition Condition)

Set the acquisition conditions when the acquisition mode is memory (Memory) or memory + save on stop (Memory + Save on Stop).

Set the recording start and end conditions. The following three acquisition conditions are available.

Acquisition Time (Acquisition Time)

When you press the START/STOP button, data recording starts. When the specified acquisition time elapses, the instrument automatically stops recording. The measurement start time becomes the time reference point.

Continuous Acquisition (Continuous)

When you press the START/STOP button, data recording starts. Acquisition continues even when the specified record time elapses. When you stop recording by pressing the START/STOP button, the past data from when the acquisition ended to the specified record time is saved. The measurement end time becomes the time reference point.

Trigger Acquisition (Capture on Trigger)

When you press the START/STOP button, the instrument enters the trigger-wait state. When a trigger occurs, recording starts. When the specified acquisition time elapses, the instrument automatically stops recording. The trigger time becomes the time reference point. You can set the pre-trigger ratio on the menu that appears when you press MENU (ACTION).

Acquisition Method (Acquisition Method)

Set the acquisition method. The following three acquisition methods are available.

- **Memory (Memory)**
Data is saved to the acquisition memory.
- **Memory + Save on Stop (Memory + Save on Stop)**
Data is saved to the acquisition memory. When the measurement is finished, an action can be executed. Set the action items with detail settings. ► [See here.](#)
- **SSD Recording (SSD Recording)**
Data is acquired in [SSD recording](#) mode. Configure the SSD recording with detail settings. ► [See here.](#)

Detailed Recorder Mode Setup (Detail)

These are settings available in Recorder mode.

Acquisition Method (Acquisition Method)

- **When the acquisition method is Memory + Save on Stop (Memory + Save on Stop)**
Select the check boxes for the actions you want to execute. The available actions are listed below.
 - Save waveform data (Save Waveform)
 - Save screen capture (Save Image)
 - Save measured values (Measure Value Save)
 - Beep (Beep)
 - Send Mail (Send Mail)
- Save on Stop Setup (Save on Stop Setup)
This is the same as the setting for the action feature. ► [See here.](#)
- **When the acquisition method is SSD recording**
Set the following SSD recording items. ► [See here.](#)
 - Auto Naming (Auto Naming)
 - Prefix Name (Prefix Name)
 - Comment (Comment)
 - File Division (File Divide)

Acquisition Mode (Acquisition Mode)

▶ [See here.](#)

Time Base (Time Base)

▶ [See here.](#)

Waveform Acquisition (START/STOP)**Scope Mode****When Dual Capture Mode Is Off**

The instrument starts and stops acquiring waveforms according to the trigger mode setting.

When you start waveform acquisition, the instrument stores waveform data to the acquisition memory and updates the displayed waveforms each time it triggers. The acquisition memory is divided into many areas based on the set record length, and the maximum number of acquirable waveforms are stored in the memory. You can recall past waveforms that are stored in the memory by using the history feature when waveform acquisition is stopped.

**Instrument Operation When the Acquisition Mode Is Set to Averaging**

- Averaging stops when you stop acquisition.
- If you start acquisition again, averaging starts from the beginning.

START/STOP Key Operations during Accumulation

- Accumulation pauses when you stop waveform acquisition.
- When you restart acquisition, accumulation resumes from the condition that it was in when it was stopped.

When Dual Capture Mode Is On

The instrument starts and stops acquiring waveforms according to the capture mode setting.

When the low-speed sampling waveform acquisition is finished, high-speed sampling waveform acquisition also stops.

High-speed sampling waveforms are acquired to the acquisition memory each time a trigger occurs, in the same manner as when dual capture is off. The trigger mode is fixed to Normal.

Recorder Mode

The instrument starts and stops acquiring waveforms according to the acquisition condition.



- The START/STOP key is invalid in the following cases.
 - When the instrument is in remote mode.
 - When the instrument is printing to a printer, when it is being set up automatically, or when it is accessing a storage device.
- If you change the waveform acquisition conditions and start waveform acquisition, the past data stored in the acquisition memory is cleared.
- You can use the snapshot feature to retain the displayed waveform on the screen. This feature allows you to update the display without having to stop waveform acquisition.
- Regardless of the trigger settings, you can make the instrument trigger by pressing the MANUAL key.

4 Trigger

Triggers are events used to display waveforms. When the specified trigger condition is met, a trigger occurs, and a waveform is displayed on the screen.

Trigger Settings (Setting)

This is a setting available in Scope mode. The following trigger types are available.

- [Simple \(Simple\)](#)
- [Enhanced \(Enhanced\)](#)

Simple (Simple)

- [Simple trigger](#): Simply triggers on a trigger source edge.

In addition to using the signals (analog signals and logic signals) applied to the modules installed in the slots as trigger sources, you can also use the time, an external signal (the signal applied to the TRIG terminal), or the power line signal.

Enhanced (Enhanced)

Select the trigger type (Type) from the following.

- [A to B \(N\) trigger](#): After state condition A is met, the instrument triggers when state condition B is met N times.
- [A Delay B trigger](#): After state condition B is met and the specified amount of time elapses, the instrument triggers when state condition A is first met.
- [Edge On A trigger](#): While state condition A is met, the instrument triggers on the OR of multiple trigger source edges.
- [OR trigger](#): The instrument triggers on the OR of multiple trigger source edges.
- [AND trigger](#): The instrument triggers on the AND of multiple trigger source conditions.
- [Period trigger](#): The instrument triggers on a specified period of occurrence of state condition B.
- [Pulse Width trigger](#): The instrument triggers after state condition B has been met for a specified duration (width).
- [Wave Window trigger](#): The instrument creates real-time templates (Wave Window) using a number of cycles directly preceding the current waveforms. The instrument compares the current waveforms to the real-time templates and triggers if one of the current waveforms falls outside of its real-time template.

- * A state condition is a condition that is met when the levels of specified trigger sources are High or Low relative to a specified trigger level. If you set a signal to X (Don't Care), the state of the specified signal is not used to determine whether the state condition is met.

Manual Trigger (MANUAL)

Regardless of the trigger settings, you can make the instrument trigger by pressing the MANUAL key on the front panel.

Trigger Type (Type)

This is a setting available in Recorder mode.

You can use the following triggers when the acquisition condition (Acquisition Condition) is set to trigger acquisition (Capture on Trigger).

- [Edge](#): Simply triggers on a trigger source edge.
- [Time trigger](#): Triggers at the specified time.
- [OR trigger](#): The instrument triggers on the OR of multiple trigger source edges.
- [AND trigger](#): The instrument triggers on the AND of multiple trigger source conditions.

Manual Trigger (MANUAL)

Regardless of the trigger settings, you can make the instrument trigger by pressing the MANUAL key on the front panel.

Signal Type and Trigger Type Combinations

The signal type (analog or logic) determines what trigger types you can use.

Scope Mode

	CH1 to CH16		
	Analog Signal (including sub channels)	Logic Signal Bit 1 to Bit 8	Mixed
Simple	Y	Y	—
A to B(N)	Y	Y	Y
A Delay B	Y	Y	Y
Edge On A	Y	Y	Y
OR	Y	Y	Y
AND	Y	Y	Y
Period	Y	Y	Y
Pulse width	Y	Y	Y

About the Wave Window trigger ► [See here.](#)

Recorder Mode

	CH1 to CH16		
	Analog Signal (including sub channels)	Logic Signal Bit 1 to Bit 8	Mixed
Edge	Y	Y	—
OR	Y	Y	Y
AND	Y	Y	Y

Basic Trigger Settings

- **Trigger source:** The trigger source signal.
- **Trigger slope:** Specifies which edge, rising or falling, the instrument will trigger on.
- **Trigger level:** The trigger determination level.
- **Trigger hysteresis:** The trigger level margin (the instrument does not trigger on changes in the signal level within this margin).

Scope Mode Only

- **Trigger position:** The position where the trigger point will be displayed (applies to all trigger types).
- **Trigger hold-off:** The amount of time to wait before the next trigger detection (applies to all triggers except for the simple trigger when the trigger source is Time, the period trigger, and the manual trigger).
- **Trigger delay:** The delay from the trigger point (applies to all trigger types).

Recorder Mode Only

- **Pre-trigger:** The ratio of the time before a trigger occurs within the specified waveform acquisition time (pre-trigger) (applies to all trigger types).

Simple Trigger (Simple)

The instrument triggers on trigger source edges (rising or falling edges). *Edge* refers to a point where the trigger source passes through the trigger level.

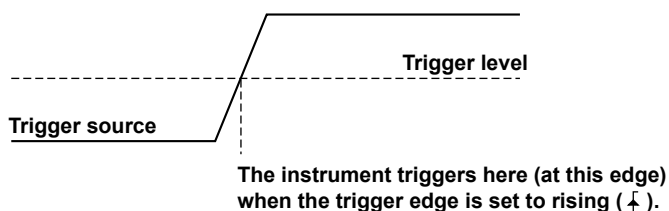

Trigger Source (Source)

Trigger source refers to the signal used to determine whether the specified trigger conditions are met. Select from the following.

Analog Signal (CH1 to CH16)

Select a channel from CH1 to CH16 to use the analog signal being applied to the corresponding terminal as the trigger source.

CH1 to CH16,¹ 16chTEMP/VOLT,² CAN,³ LIN,³ SENT³

- 1 You can select the channel of an installed module. On a 4-CH module, select sub channel 1 or 2.
- 2 When a 16-CH Temperature/Voltage Input Module is installed. Select 16CH TEMP/VOLT and then a sub channel.
- 3 On models with the /VCE option when a CAN bus monitor, CAN/CAN FD monitor, CAN & LIN bus monitor, or SENT monitor module is installed. After you select CAN, LIN, or SENT, select a sub channel. However, you cannot select a sub channel whose Input setting is set to OFF. ► [See here.](#)

Logic Signal (Bit 1 to Bit 8)

Select a bit from 1 to 8 to use the logic signal being applied to the port of a logic input module. When a logic input module is installed in a slot, bits 1 to 8 appear as options below the channel (CH1 to CH16) that corresponds to that slot.

Real Time Math Result (RTmath1 to RTmath16)

Select a real time math result to use it as a trigger source. However, you cannot select a sub channel whose Input setting is set to OFF.

Time (Time)

Select Time to use the date and time as the trigger source. The trigger occurs at the specified date and time and at specified intervals afterwards.

- Specify the year, month, day, hour, minute, and second.
- You can select one of the time intervals listed below.
10 sec, 15 sec, 20 sec, 30 sec, 40 sec, 50 sec, 1 min, 2 min, 3 min, 4 min, 5 min, 6 min, 7 min, 8 min, 9 min, 10 min, 15 min, 20 min, 25 min, 30 min, 40 min, 45 min, 50 min, 1 hour, 2 hour, 3 hour, 4 hour, 5 hour, 6 hour, 7 hour, 8 hour, 9 hour, 10 hour, 11 hour, 12 hour, 18 hour, 24 hour

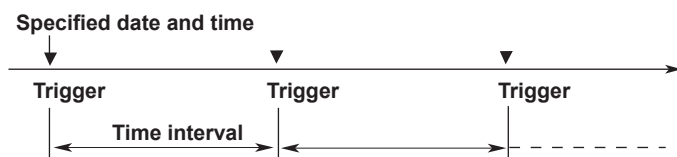



- Depending on the specified time interval, a trigger may occur while the waveform is being acquired or in the pre-trigger section (the section before the trigger that is acquired for observation). When this happens, the trigger is ignored.
 - If the specified date and time fall within the pre-trigger section, a trigger occurs at the end of the pre-trigger section.
 - If the specified date and time are in the past, triggers occur at the points in the present defined by the function (specified date and time) + (time interval × integer N).
 - If you set the [number of acquisitions](#), the specified number of waveforms are acquired. When the specified number of acquisitions is infinite, waveform acquisition continues until you press START/STOP.
-

External Signal (External)

Select External to use the signal that is received through the left-panel TRIG IN terminal as the trigger source.

Power Line Signal (Line)

Select this when using the power supplied to this instrument as a trigger source. The instrument only triggers on the rising edge. Waveforms can be observed in sync with the power line frequency (50 Hz or 60 Hz).

Trigger Level (Level)

Trigger level refers to the signal level used as a reference for detecting a source signal's rising and falling edges or high and low states. With simple triggers such as the edge trigger, the instrument triggers when the trigger source level passes through the specified trigger level.

The range and resolutions that you can use to set the trigger level vary depending on the type of signal being measured.

When Measuring Voltage

Selectable range: ± 10 div (two times the display range)

Resolution: 0.01 div. (Example: when the probe attenuation is 1:1 and the voltage scale is 2 mV/div, the resolution is 0.02 mV.)

When Measuring Temperature

Selectable range: The range of thermocouple being used. Resolution: 0.1 °C or 0.1 K

When Measuring Strain

Selectable range: Selectable range: The range of the strain module being used. Resolution: 1 μ STR or 0.0005 mV/V

When Measuring Acceleration

Selectable range: ± 10 div, resolution: 0.01 unit (set the unit in the channel settings)

When Measuring Frequency (Revolutions, periods, duty cycles, power supply frequencies, pulse widths, pulse integration, velocities)

Selectable range: ± 10 div, resolution: 0.5 unit (the unit varies depending on the measurement function)

When Monitoring CAN Bus, LIN Bus or SENT Signals

When the Data Type (Value Type) is Unsigned or Signed

Selectable range: The settable value is determined from the bit length (Bit Count) of the relevant sub channel.

Resolution: Scaling factor (Factor)

When the Data Type (Value Type) is Float

Selectable range: (The span between the upper (Upper) and lower (Lower) limits of the display range) × 2

Resolution: (Span × 2)/48000

Trigger Slope (Slope)

Slope refers to the movement of the signal from a low level to a high level (rising edge) or from a high level to a low level (falling edge). When a slope is used as one of the trigger conditions, it is called a *trigger slope*.

The following trigger slope settings are available for triggering the instrument.

\uparrow	The instrument triggers when the trigger source changes from a level below the trigger level to a level above the trigger level (rising).
\downarrow	The instrument triggers when the trigger source changes from a level above the trigger level to a level below the trigger level (falling).
\updownarrow	The instrument triggers on both rising and falling edges.

* \updownarrow cannot be selected when simple trigger is in use and the trigger source is a logic signal or external signal.

Trigger Hysteresis (Hysteresis)

Trigger hysteresis establishes a trigger level margin (hysteresis) so that the instrument does not trigger if the signal level change is within the margin.

Select the hysteresis from one of the following settings below. You can set the following hysteresis around the trigger level for each type of measured signal. You cannot set the hysteresis when the trigger source is set to Time, External, Line, or a logic signal.

	∇	∇	∇
Voltage	Approx. ± 0.1 div	Approx. ± 0.5 div	Approx. ± 1 div
Temperature	Approx. ± 0.5 °C (K)	Approx. ± 1 °C (K)	Approx. ± 2 °C (K)
Strain	Approx. ± 2.5 % of the range	Approx. ± 12.5 % of the range	Approx. ± 25 % of the range
Acceleration	Approx. ± 0.1 div of the range	Approx. ± 0.5 div of the range	Approx. ± 1 div of the range
Frequency, CAN, LIN, SENT	Approx. ± 0.01 div of the range	Approx. ± 0.5 div of the range	Approx. ± 1 div of the range

* The above values are approximate values. They are not strictly warranted.

Trigger Position (Position)

This is a setting available in Scope mode. When you move the trigger position, the ratio of the displayed data before the trigger point (the pre-trigger section) to the data after the trigger point (the post-trigger point) changes. When the trigger delay is 0 s, the trigger point and trigger positions coincide.

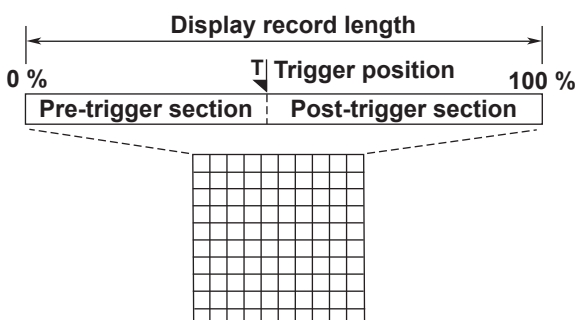

Selectable range: 0.0 to 100 % of the display record length

Resolution: 0.1 %



- When waveform acquisition is stopped, if you change the trigger position, the setting is not applied until you start waveform acquisition and update the waveforms.
- If you change the time scale (TIME/DIV knob), the location of the trigger position does not change.

Time Reference Point

In addition to the trigger position, a time reference point is indicated. The times that appear in the lower left and right of the screen are the times from this time reference point. The cursor time-measurement values are also based on this reference point.

When waveform acquisition is stopped, the displayed location of the time reference point varies as indicated below.

- **In Update Mode**

When the displayed waveform is updated by a trigger, the time reference point is displayed as indicated below. The time reference point and the trigger point are the same.

- Under Normal Waveform Update Conditions When All Pre-Trigger and Post-Trigger Data Has Been Acquired

The trigger position and the time reference point are displayed at the same position.

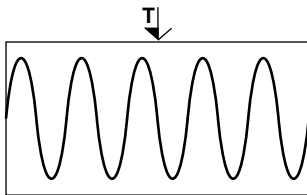

- When Waveform Acquisition Is Stopped before All Pre-Trigger and Post-Trigger Data Has Been Acquired

The trigger position and the time reference point are displayed separately.

Trigger position Time reference point

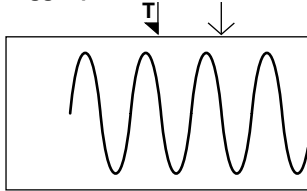

- **In Roll Mode**

In roll mode, in which waveforms scroll from right to left, the time reference point is displayed as indicated below.

- When the Trigger Mode Is Auto Mode or Auto Level Mode

The point in time when waveform acquisition was stopped is the time reference point (right side of the screen).

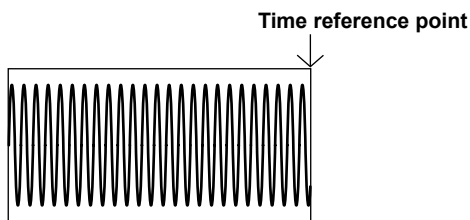

- When the Trigger Mode Is Instant Start Mode (On Start)

The point in time when waveform acquisition was started is the time reference point.

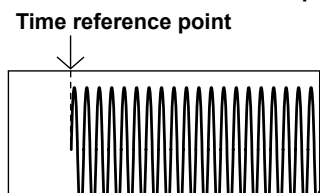

Trigger Hold-off (Hold Off)

This is a setting available in Scope mode. The trigger hold-off feature temporarily stops the detection of the next trigger once a trigger has occurred. This feature is useful, for example, when you want to change the signal acquisition interval while you are observing a pulse code modulation (PCM) code or other pulse train signal or when you are using the history feature.

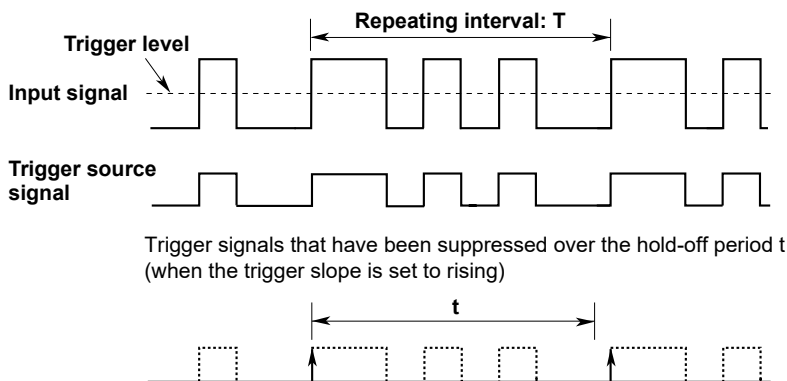

Selectable range: 0.00 μ s to 10000000.00 μ s (10 s). The default setting is 0.00 μ s.
Resolution: 0.01 μ s



- To trigger with the hold-off time set to 50 ms or more, set the trigger mode to Normal.
- For the A to B (N) and A Delay B triggers, the hold-off time applies only to state condition B.
- The trigger hold-off feature does not apply to Simple, Period, or manual trigger when the trigger source is Time.

Trigger Delay (Delay Time)

This is a setting available in Scope mode. The instrument normally displays waveforms before and after the trigger point. You can set a trigger delay to display waveforms that the instrument has acquired a specified amount of time after the trigger occurrence.

Selectable range: 0.00 μ s to 10000000.00 μ s (10 s). The default setting is 0.00 μ s. (The number of decimal places varies depending on the resolution.)

The resolution varies depending on sample rate. For 10 MS/s, the resolution is 0.01 μ s.

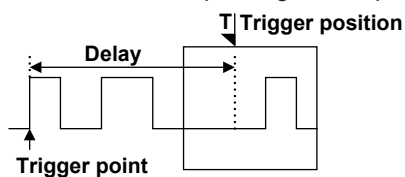

- If you change the time scale (TIME/DIV knob) so that the unit becomes larger, because of display-digit limitations, the delay time that you set when the unit was small will not appear in the setup menu, but it is retained.
- You cannot specify a trigger delay when an external clock is being used as the time base.

Trigger Mode (Trigger Mode)

This is a setting available in Scope mode. This is synchronized with the trigger mode on the ACQUIRE menu.

▶ [See here.](#)

- This is fixed to Normal when dual capture is on.
- This setting is not displayed when synchronous operation is being performed in multi-unit synchronization mode (/C50 option).

Pre-Trigger (Pre Trigger)

This is a setting available in Recorder mode.

Set the ratio of the pre-trigger section to the waveform acquisition time.

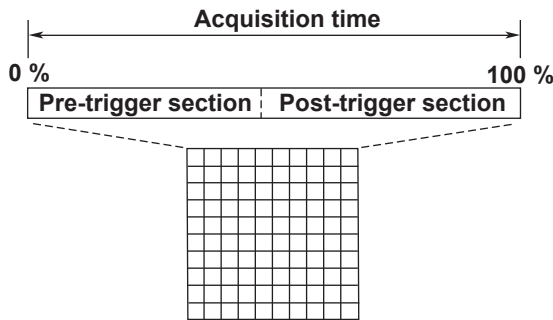

Selectable range: 0.0 to 100 % of the waveform acquisition time

Resolution: 0.1 %

Unit Setting (Unit Setting)

This is a setting for when synchronous operation is being performed in multi-unit synchronization mode (/C50 option).

Select which DL950's (unit's) trigger conditions will be used for triggering from the following options.

MainUnit, SubUnit1, SubUnit2, SubUnit3, SubUnit4

- Only the names of the units in synchronous operation are displayed in the menu options.
- The setting method varies depending on the trigger type as follows:

Operation Mode	Trigger Type	Single Selection	Multiple Selections ³	Fixed to MainUnit
Scope mode ¹	Simple (Time, External)	—	—	Y
	Simple (other than Time or External)	Y	—	—
	Enhanced (OR only)	—	Y	—
Recorder Mode ²	Edge (External)	—	—	Y
	Edge (other than External)	Y	—	—
	Time	—	—	Y
	OR	—	Y	—

- 1 Simple's Line cannot be used during synchronous operation. Enhanced triggers other than OR cannot be used.
- 2 AND cannot be used during synchronous operation.
- 3 All selected units are turned on.

A to B (N) Trigger (Enhanced)

This is a setting available in Scope mode. After state condition A is met, the instrument triggers when state condition B is met N times.

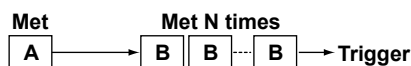

Trigger Sources

You can use CH1 to CH16, Bit 1 to Bit 8, and RTmath1 to RTmath16 as the trigger sources. Bit 1 to Bit 8 appears as options when a logic input module is installed in a slot.

▶ [See here.](#)

State Condition (A State, B State)

To set state conditions A and B, select the states of the trigger sources in relation to the trigger level.

Example

	State condition A	State condition B
CH1	H	H
CH2	L	L
CH3-		
Bit 1	L	H
Bit 2	H	X
.....
Bit 8	X	L
CH4	X	X
.....
CH16	X	H

H: When the signal level is high
L: When the signal level is low
X: Don't care

State Condition Achievement Conditions (A Condition, B Condition)

Select how the result of comparing the trigger source states to their specified conditions (true or false) must change for the state condition to be considered met.

Enter	When the result changes from false to true
Exit	When the result changes from true to false

Number of Times State Condition B Must Be Met (Count)

Set the number of times state condition B must be met.

Selectable range: 1 to 10000. The default setting is 1.

Trigger Level (Level) and Trigger Hysteresis (Hys)

Set these items for each trigger source. These items are the same as those of the simple trigger.

- Trigger level ▶ [See here.](#)
- Hysteresis ▶ [See here.](#)

Trigger Hold-off (Hold Off)/ Trigger Position (Position)/ Trigger Delay (Delay Time)

These items are the same as those of the simple trigger.

- Trigger hold-off ▶ [See here.](#)
- Trigger position ▶ [See here.](#)
- Trigger delay ▶ [See here.](#)

A Delay B Trigger (Enhanced)

This is a setting available in Scope mode. After state condition B is met and the specified amount of time elapses, the instrument triggers when state condition A is first met.

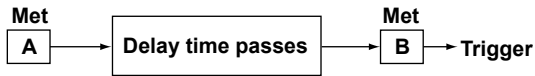

Trigger Sources

You can use CH1 to CH16, Bit 1 to Bit 8, and RTmath1 to RTmath16 as the trigger sources. Bit 1 to Bit 8 appears as options when a logic input module is installed in a slot.

▶ [See here.](#)

State Condition (A State, B State)

To set state conditions A and B, select the states of the trigger sources in relation to the trigger level.

Example

	State condition A	State condition B
CH1	H	H
CH2	L	L
CH3-		
Bit 1	L	H
Bit 2	H	X
.....
Bit 8	X	L
CH4	X	X
.....
CH16	X	H

H: When the signal level is high
 L: When the signal level is low
 X: Don't care

State Condition Achievement Conditions (A Condition, B Condition)

Select how the result of comparing the trigger source states to their specified conditions (true or false) must change for the state condition to be considered met.

Enter	When the result changes from false to true
Exit	When the result changes from true to false

Delay Time (Delay Time)

Set the elapsed time from when state condition A is met.

Selectable range: 0.0 μs to 10000000.00 μs (10 s). The default setting is 0.00 μs.

Resolution: 0.01 μs

Trigger Level (Level) and Trigger Hysteresis (Hys)

Set these items for each trigger source. These items are the same as those of the simple trigger.

- Trigger level ▶ [See here.](#)
- Hysteresis ▶ [See here.](#)

Trigger Hold-off (Hold Off)/ Trigger Position (Position)/ Trigger Delay (Delay Time)

These items are the same as those of the simple trigger.

- Trigger hold-off ▶ [See here.](#)
- Trigger position ▶ [See here.](#)
- Trigger delay ▶ [See here.](#)

Edge On A Trigger (Enhanced)

This is a setting available in Scope mode. While state condition A is met, the instrument triggers on the OR of multiple trigger source edges.

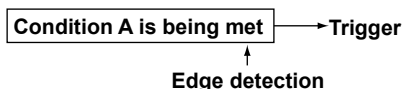

Trigger Sources

You can use CH1 to CH16, Bit 1 to Bit 8, and RTmath1 to RTmath16 as the trigger sources. Bit 1 to Bit 8 appears as options when a logic input module is installed in a slot.

▶ [See here.](#)

State Condition (A State)

To set state condition A, select the states of the trigger sources in relation to the trigger level.

Example

	State condition A
CH1	H
CH2	L
CH3-	
Bit 1	L
Bit 2	H
.....	...
Bit 8	X
CH4	X
.....	...
CH16	X

H: When the signal level is high
L: When the signal level is low
X: Don't care

State Condition Achievement Condition (Condition)

Select whether the result of comparing the trigger source states to their specified conditions must be true or false for the state condition to be considered met.

True	The result must be true.
False	The result must be false.

Edge Detection Condition (Edge)

Set the condition for detecting the trigger source edge.

\uparrow	When the trigger source changes from a level below the trigger level to a level above the trigger level (rising)
\downarrow	When the trigger source changes from a level above the trigger level to a level below the trigger level (falling)
—	The signal is not used as a trigger condition.

Trigger Level (Level) and Trigger Hysteresis (Hys)

Set these items for each trigger source. These items are the same as those of the simple trigger.

- Trigger level ▶ [See here.](#)
- Hysteresis ▶ [See here.](#)

Trigger Hold-off (Hold Off)/ Trigger Position (Position)/ Trigger Delay (Delay Time)

These items are the same as those of the simple trigger.

- Trigger hold-off ▶ [See here.](#)
- Trigger position ▶ [See here.](#)
- Trigger delay ▶ [See here.](#)

OR Trigger (Enhanced)

The instrument triggers on the OR of multiple trigger source edges.

Trigger Sources

You can use CH1 to CH16, Ext (external signal applied to the TRIG IN terminal), Bit 1 to Bit 8, and RTmath1 to RTmath16 as trigger sources. Bit 1 to Bit 8 appears as options when a logic input module is installed in a slot.

▶ [See here.](#)

Edge Detection Condition (Edge)

Set the conditions for detecting each trigger source edge.

\uparrow	When the trigger source changes from a level below the trigger level to a level above the trigger level (rising)
\downarrow	When the trigger source changes from a level above the trigger level to a level below the trigger level (falling)
IN	An edge is detected when the trigger source enters the specified level range.
OUT	An edge is detected when the trigger source leaves the specified level range.
—	The signal is not used as a trigger condition.

* IN and OUT are selectable only when the trigger source is an analog signal (CH1 to CH16, RTmath1 to RTmath16).

Trigger Level (Level)

Set these items for each trigger source.

When the Edge Detection Condition Is \uparrow or \downarrow

Set the level used to detect the trigger source's rising or falling edge.

▶ [See here.](#)

When the Edge Detection Condition Is IN or OUT

An edge is detected when the trigger source enters (IN) or leaves (OUT) the specified level range. You can specify the level range settings for each analog signal trigger source.

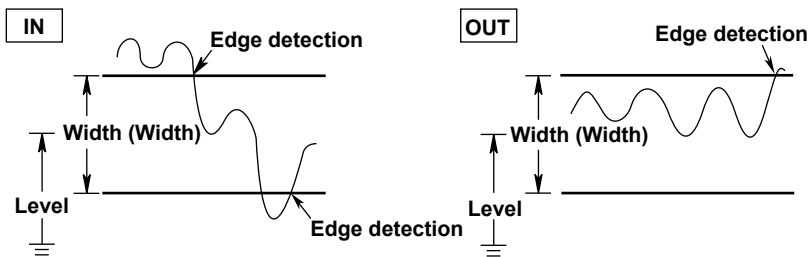

Setting	Selectable Range	Resolution
Level (center value)	Same as the trigger level	
Width (Width)		

Trigger Hysteresis (Hys)

Set these items for each trigger source.

This item is the same as the hysteresis of the simple trigger.

▶ [See here.](#)

Trigger Hold-off (Hold Off)/ Trigger Position (Position)/ Trigger Delay (Delay Time)

These items are the same as those of the simple trigger.

- Trigger hold-off ▶ [See here.](#)
- Trigger position ▶ [See here.](#)
- Trigger delay ▶ [See here.](#)

Pre-Trigger (Pre Trigger)

This is a setting available in Recorder mode. Set the ratio of the pre-trigger section to the waveform acquisition time. ▶ [See here.](#)

AND Trigger (Enhanced)

The instrument triggers on the AND of multiple trigger source conditions. The instrument triggers when all the specified conditions are met at a single point.

Trigger Sources

You can use CH1 to CH16, Bit 1 to Bit 8, and RTmath1 to RTmath16 as the trigger sources. Bit 1 to Bit 8 appears as options when a logic input module is installed in a slot.

▶ [See here.](#)

Achievement Condition (Condition)

Set the achievement condition for each trigger source.

H	The signal level must be high.
L	The signal level must be low.
IN	The signal must be within the specified level range.
OUT	The signal must be outside of the specified level range.
—	The signal is not used as a trigger condition.

* IN and OUT are selectable only when the trigger source is an analog signal (CH1 to CH16, RTmath1 to RTmath16).

Trigger Level (Level)

Set these items for each trigger source.

When the Achievement Condition Is H or L

Set the level for determining whether the trigger sources are high or low.

▶ [See here.](#)

When the Achievement Condition Is IN or OUT

An edge is detected when the trigger source enters (IN) or leaves (OUT) the specified level range. You can specify the level range settings for each analog signal trigger source.

▶ [See here.](#)

Trigger Hysteresis (Hys)

Set these items for each trigger source.

This item is the same as the hysteresis of the simple trigger.

▶ [See here.](#)

Trigger Hold-off (Hold Off)/ Trigger Position (Position)/ Trigger Delay (Delay Time)

These items are the same as those of the simple trigger.

- Trigger hold-off ▶ [See here.](#)
- Trigger position ▶ [See here.](#)
- Trigger delay ▶ [See here.](#)

Pre-Trigger (Pre Trigger)

This is a setting available in Recorder mode. Set the ratio of the pre-trigger section to the waveform acquisition time. ▶ [See here.](#)

Period Trigger (Enhanced)

This is a setting available in Scope mode. The instrument triggers on a specified period of occurrence of state condition B. The instrument triggers when state condition B occurs again.

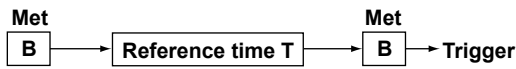

Trigger Sources

You can use CH1 to CH16, Bit 1 to Bit 8, and RTmath1 to RTmath16 as the trigger sources. Bit 1 to Bit 8 appears as options when a logic input module is installed in a slot.

▶ [See here.](#)

State Condition (B State)

To set state condition B, select the states of the trigger sources in relation to the trigger level.

Example

	State condition B
CH1	H
CH2	L
CH3-	
Bit 1	L
Bit 2	H
.....	...
Bit 8	X
CH4	X
.....	...
CH16	X

H: When the signal level is high
 L: When the signal level is low
 X: Don't care

Determination Mode (Mode)

Set what kind of relationship must be established between period T and the specified reference times (Time or T1 and T2) for the instrument to trigger.

T < Time	Period T must be shorter than the reference time (Time).
T > Time	Period T must be longer than the reference time (Time).
T1 < T < T2	Period T must longer than reference time T1 and shorter than reference time T2.
T < T1, T2 < T	Period T must be shorter than reference time T1 or longer than reference time T2.

Reference Times (Time, T1, T2)

You can set the reference times (Time, T1, and T2) within the following ranges.

Setting	Selectable Range	Default Value	Resolution
Time	0.02 μs to 10000000.00 μs (10 s)	0.02 μs	
T1	0.02 μs to 9999999.99 μs	0.02 μs	0.01 μs
T2	0.03 μs to 10000000.00 μs (10 s)	0.03 μs	

Trigger Level (Level) and Trigger Hysteresis (Hys)

Set these items for each trigger source. These items are the same as those of the simple trigger.

- Trigger level ▶ [See here.](#)
- Hysteresis ▶ [See here.](#)

Trigger Hold-off (Hold Off)/ Trigger Position (Position)/ Trigger Delay (Delay Time)

These items are the same as those of the simple trigger.

- Trigger hold-off ▶ [See here.](#)
- Trigger position ▶ [See here.](#)
- Trigger delay ▶ [See here.](#)

Pulse Width Trigger (Enhanced)

This is a setting available in Scope mode. The instrument triggers according to a specified duration (achievement time) for which state condition B has been met. The timing of the triggering varies depending on the determination mode.

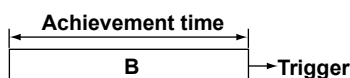

Trigger Sources

You can use CH1 to CH16, Bit 1 to Bit 8, and RTmath1 to RTmath16 as the trigger sources. Bit 1 to Bit 8 appears as options when a logic input module is installed in a slot.

▶ [See here.](#)

State Condition (B State)

To set state condition B, select the states of the trigger sources in relation to the trigger level.

Example

	State condition B
CH1	H
CH2	L
CH3-	
Bit 1	L
Bit 2	H
.....	...
Bit 8	X
CH4	X
.....	...
CH16	X

H: When the signal level is high
L: When the signal level is low
X: Don't care

Determination Mode (Mode)

Set what kind of relationship must be established between the state condition B achievement time and the specified reference times (Time or T1 and T2) for the instrument to trigger.

B < Time	The instrument triggers when the achievement time is shorter than the reference time (Time), and the state condition changes to not met.
B > Time	The instrument triggers when the achievement time is longer than the reference time (Time), and the state condition changes to not met.
B TimeOut	The instrument triggers when the achievement time is longer than the reference time (Time).
B Between	The instrument triggers when the achievement time is longer than reference time T1 and shorter than reference time T2, and the state condition changes to not met.

Reference Times (Time, T1, T2)

You can set the reference times (Time, T1, and T2) within the following ranges.

Setting	Selectable Range	Default Value	Resolution
Time	0.02 μ s to 10000000.00 μ s (10 s)	0.02 μ s 0.01 μ s for B TimeOut	0.01 μ s
T1	0.01 μ s to 9999999.99 μ s	0.01 μ s	
T2	0.02 μ s to 10000000.00 μ s (10 s)	0.02 μ s	



Triggering may not function properly when the interval between achievement times is less than 0.01 μ s or when the duration of the achievement time is less than 0.01 μ s (Typical).

Trigger Level (Level) and Trigger Hysteresis (Hys)

Set these items for each trigger source. These items are the same as those of the simple trigger.

- Trigger level ▶ [See here.](#)
- Hysteresis ▶ [See here.](#)

Trigger Hold-off (Hold Off)/ Trigger Position (Position)/ Trigger Delay (Delay Time)

These items are the same as those of the simple trigger.

- Trigger hold-off ▶ [See here.](#)
- Trigger position ▶ [See here.](#)
- Trigger delay ▶ [See here.](#)

Wave Window Trigger (Enhanced)

This is a setting available in Scope mode when dual capture is off. The instrument creates real-time templates (Wave Window) using a number of cycles directly preceding the current waveforms. The instrument compares the current waveforms to the real-time templates and triggers if one of the current waveforms falls outside of its real-time template.

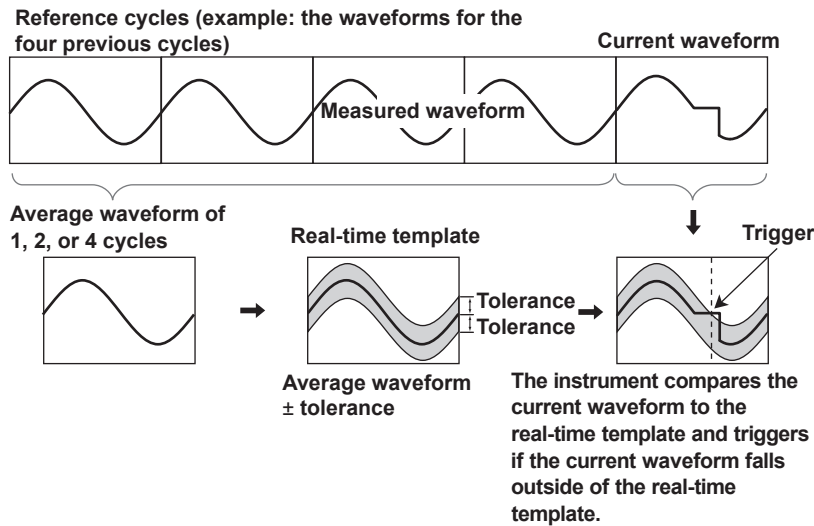

Trigger Sources

You can select the trigger sources from CH1 to CH16.

The modules that you can use as sources for the Wave Window trigger are listed below. You cannot use other modules or temperature-measurement channels as sources.

720256 (4CH10M16)	701250 (HS10M12)
720250 (HS10M12)	701251 (HS1M16)
701255 (NONISO_10M12)	720268 (HV (AAF, RMS))
701261 (UNIVERSAL) (only voltage measurement)	701262 (UNIVERSAL (AAF)) (only voltage measurement)
701270 (STRAIN_NDIS)	701271 (STRAIN_DSUB)
701275 (ACCL/VOLT)	720212 (HS200M14)
720211 (HS100M12)	720254 (4CH 1M16)

Template Channels (Condition)

Select which trigger sources to use to make real-time templates (up to eight channels simultaneously). The instrument triggers if the condition of even one of the channels is met.

ON	Use
OFF	Don't use

Tolerance Width (Width)

To create a real-time template for a channel, set the distance from the averaged waveform (of 1, 2, or 4 cycles before the current waveform) that will be tolerated. The range within which you can set the distance varies depending on the type of signal being measured.

Measured Item	Selectable Range	Default Value	Resolution
Voltage	0.01 × the voltage scale to 10 × the voltage scale	0.01 div	Same as the trigger level resolution ▶ See here.
Strain	1 μSTR to (measurement range) × 2 or 0.0005 mV/V to (measurement range) × 2	1 μSTR 0.0005 mV/V	
Acceleration	0.01 Unit to (Unit/div) × 10	10 mUnit	

For example, when Width is set to 2 V, the tolerance width is ±2 V around the averaged waveform.

Cycle Frequency (Cycle Frequency)

Set the trigger source frequency. If the actual frequency is within ±10 % of the specified value, it is automatically tracked.

Selectable range: 40 Hz to 1000 Hz. The default setting is 50 Hz.

Resolution: 1 Hz

Reference Cycles (Reference Cycle)

Select how many waveforms before the current waveform are used to create the real-time templates.

1	The previous waveform is used.
2	Two previous waveforms are used.
4	Four previous waveforms are used.



If a surge or other abnormal waveform occurs in the reference cycle, the abnormal waveform will be included in the averaged waveform, so the instrument will trigger on the next normal waveform. This may make it appear as if the trigger has been delayed by a few cycles.

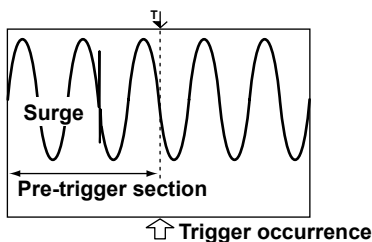

When using the wave window trigger, we recommend that you set the pre-trigger longer than the reference cycle. You can observe abnormal waveforms on the screen even when they occur within the reference cycle.

Sync Channel (Sync. Ch)

Select the channel used to detect the points at which waveform comparison for the wave window trigger starts and stops. Select the synchronization channel by selecting Auto or a channel from CH1 to CH16 that has a module that the wave window trigger can be used with.

Auto:

Of the modules that the wave window trigger can be used with, the channel with the smallest number is automatically selected.

Level for detecting the start and end points: The center of the amplitude of the sync-channel signal measured for 0.5 seconds after the start of waveform acquisition.

Detection hysteresis: Same as the edge trigger hysteresis ► [See here.](#)

CH1 to CH16

Select a channel whose module can be used with the wave window trigger. If triggering does not function properly when you select Auto, you can specify an appropriate channel.

For the selected channel, you need to set the level for detecting the start and end points and set the detection hysteresis.

Level for Detecting the Start and End Points (Level) and Detection Hysteresis (Hysteresis)

If you set the sync channel to a channel from CH1 to CH16, you need to set the level for detecting the start and end points and set the detection hysteresis.

These items are the same as those of the simple trigger.

- Trigger level ► [See here.](#)
- Hysteresis ► [See here.](#)

Trigger Hold-off (Hold Off)/ Trigger Position (Position)/ Trigger Delay (Delay Time)

These items are the same as those of the simple trigger.

- Trigger hold-off ► [See here.](#)
- Trigger position ► [See here.](#)
- Trigger delay ► [See here.](#)



Operating Conditions of the Wave Window Trigger

You can use the wave window trigger with the following waveforms and settings. You cannot use the wave window trigger when the record length is 25 kpoint or less and the time axis setting is shorter than 10 ms/div.

Source waveform	AC waveforms and triangular waveforms between 40 Hz and 1 kHz. (The trigger cannot be used with rectangular waveforms, such as inverter waveforms, or waveforms with fast rising edges.)
sample rate	10 kS/s to 500 kS/s
Acquisition mode	Normal
trigger mode	Normal, Single, Single(N) When the trigger mode is Auto or Auto Level, it is difficult for the wave window trigger to occur.
Dual capture mode	OFF

Edge Trigger (Edge)

This is a setting available in Recorder mode. The instrument triggers when the trigger source input signal passes through the specified trigger level in the specified way.

Trigger Source (Source)

This item is the same as the trigger source of the simple trigger. ► [See here.](#)

However, time (Time) and power line signal (Line) are not available.

Trigger Slope (Slope)/ Trigger Level (Level)/ Trigger Hysteresis (Hysteresis)

These items are the same as those of the simple trigger.

- Trigger slope ► [See here.](#)
- Trigger level ► [See here.](#)
- Hysteresis ► [See here.](#)

Pre-Trigger (Pre Trigger)

Set the ratio of the pre-trigger section to the waveform acquisition time. ► [See here.](#)

Time Trigger (Time)

This is a setting available in Recorder mode.

Date and time are used to trigger the instrument.

Date and Time Setting (Date/Time Setup)

The instrument triggers at the specified date and time.

Specify the year, month, day, hour, minute, and second.

Pre-Trigger (Pre Trigger)

Set the ratio of the pre-trigger section to the waveform acquisition time. ► [See here.](#)

5 Display

Window Types (DISPLAY)

This instrument has the following types of windows.

T-Y (Time axis) Waveform Display Window

- Normal Waveform Window (Main Window)

This window displays normal waveforms, which are not magnified. The displayed contents vary depending on the operation mode as follows:

- Main: Scope mode (when dual capture is off)
- TY (Low): Low-speed sampling in Scope mode (when dual capture is on)
- TY (High): High-speed sampling in Scope mode (when dual capture is on)
- TY: Recorder mode

- Zoom window

This window displays zoomed waveforms according to the settings specified with the ZOOM key.

The displayed contents vary depending on the operation mode as follows:

- Zoom1, Zoom2: Scope mode (when dual capture is off)
- Zoom (Low): Low-speed sampling in Scope mode (when dual capture is on)
- Zoom (High): High-speed sampling in Scope mode (when dual capture is on)
- Zoom: Recorder mode

FFT Window (FFT1 window, FFT2 window)

This window displays FFT waveforms according to the settings specified with the FFT key.

X-Y Window (Window1, Window2)

This window displays X-Y waveforms according to the settings specified with the X-Y key.

Harmonic Window (/G02 option)

This window displays the results of harmonic analysis using bar graphs and lists.

Extra Window

This window displays cursor measurement values, automated measurement values of waveform parameters, and so on. Use this window when the values are difficult to see because they overlap with the displayed waveform.

Switching the Menu Area Display

You can switch between the full-screen waveform display, the channel information display, and the waveform numeric-monitor display.

Display Pattern Examples (when dual capture is off in Scope mode)

When displaying the main window (Main)

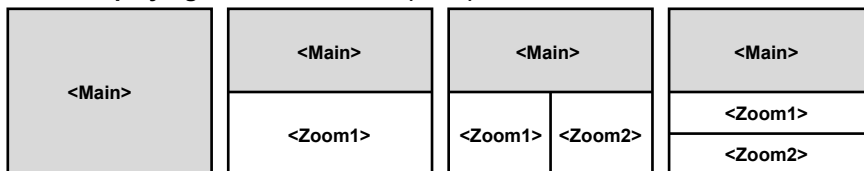

When not displaying the main window (Main)

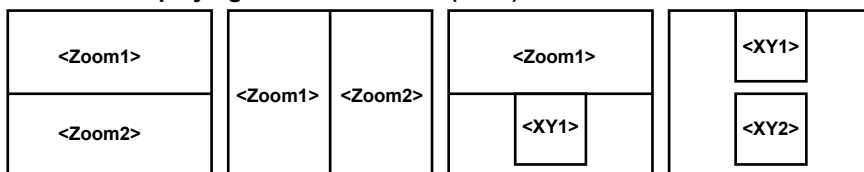

- You can display a combination of up to two windows (zoom windows, X-Y windows, FFT windows, harmonic windows) in areas other than the main window. You can also hide the main window.
- When dual capture is on, the window is split vertically between low-speed sampling and high-speed sampling. The X-Y window, FFT window and harmonic window apply only to high-speed sampling.



Since up to 64 waveforms can be displayed per display group, usually up to 192 waveforms can be displayed when all windows (the Main window, Zoom1 window, and Zoom2 window) are displayed. However, the maximum number of waveforms that can be displayed during measurement under the following conditions is 64 total. After waveform acquisition, up to 192 waveforms can be displayed.

Trigger mode: Auto
TIME/DIV: 100 ms/div or 200 ms/div

Group Selection (Select Group)

Only the waveforms of the selected group are displayed on the screen.

All channels, sub channels, RTmath, FFT, and Math are automatically assigned to Group #1 to 4, P (power analysis), H (harmonic analysis). You can change these assignments. P and H are displayed on models with the /G05 option.

Display Format (Format)

You can evenly divide the T-Y waveform display window so that you can easily view input waveforms and computed waveforms. For each group, you can set the number of divisions to one of the values listed below. When dual capture is on, you can set the number divisions for the low-speed sampling and high-speed sampling windows separately.

Group 1 (Group 1),¹ low-speed sampling (Low Speed),² 1, 2, 3, 4, 5, 6, 8, 12, 16



- 1 Group 1 is an option that appears when display group #2 to 4, P, or H is selected. Select Group 1 to set display group #2 to 4 to the same format as group 1.
- 2 This option is displayed for high-speed sampling when dual capture is on. Select this to use the same format as low-speed sampling.



The number of displayed points in each division varies depending on the number of divisions. Even if the number of displayed points changes, the vertical resolution does not change.

Grid (Graticule)

You can set the window grid to one of the following options.

-  : Displays the grid with dotted lines
-  : Displays the grid with a crosshair
-  : Display the grid frame.

Fine Grid (Fine Graticule)

You can set whether or not to display the fine grid.

- ON: The fine grid is displayed.
- OFF: The fine grid is not displayed.

Intensity (Brightness)

You can set the grid intensity to any of the eight available levels.

Detail Setup (Detail Setup)

Scale Display (Scale Display)

You can set whether to display the upper and lower limits (scale values) of each waveform's vertical or horizontal axes.

- OFF: Scale values are not displayed.
- Time Scale: Only the scale values of the horizontal scale (Time Scale) are displayed.
- ALL: The scale values of the vertical scale (V Scale) and horizontal scale (Time Scale) are displayed.



When the waveform screen is narrow due to the display format or zoom format, scale values may not be displayed even when the scale display is set to a setting other than OFF.

Scale Font Size (Font Size)

Set the font size of the scale value display to small (Small) or large (Large).

Horizontal Scale Display Format (Horizontal Scale Display Format)

Set the type of time to display on the horizontal scale to relative time (Relative), absolute time (Absolute), or auto (Auto).

- Auto: If the horizontal scale (TIME DIV) during measurement is greater than 6 min/div, absolute time is used. Otherwise, relative time is used.
- Relative: Relative time from the start of measurement
- Absolute: Absolute time of measurement (not selectable when the measurement time is 1 second or less)

Extra Window ON/OFF (Extra Window)

When waveforms and measured values overlap and are difficult to see, you can use the extra window to display them separately.

- ON: The extra window is displayed.
- OFF: The extra window is not displayed.

The following values appear in the extra window.

- Cursor-measurement values
- Automated measurement values of waveform parameters
- The digital values of each channel (only during roll mode display)

Analysis Result Display Lines (Analysis Max Line)

You can set the number of lines to display in the extra window between 1 and 20. The height of the extra window varies depending on the specified number of lines.



-
- The number of displayed points on the T-Y waveform display window varies depending on the height of the extra window. Even if the number of displayed points changes, the vertical resolution does not change.
 - When the extra window is displayed, depending on the Zoom Format, the scale values may overlap and be difficult to read.
-

Analysis Result Font Size (Analysis Font Size)

Set the font size to use to display analysis results in the extra window to small (Small) or large (Large). The height of the extra window varies depending on the specified font size.

Color Theme (Color Theme)

Select the screen background color from the following:

- Black (Black): The background is displayed in black.
- White (White): The background is displayed in white.
- Default (Default): The background is displayed in black in Scope mode and in white in Recorder mode.

Trace Label Display ON/OFF (Trace Label)

You can display waveform labels next to the displayed waveforms. If the waveform display is narrow because of the display format settings, labels may not be displayed.

- ON: Labels are displayed.
- OFF: Labels are not displayed.

Indicator Display ON/OFF (Level Indicator)

Select whether to display the level indicator, which indicates the level of each waveform. The level indicator is displayed on the right side of the waveform display window. The level indicator shows the current levels of the sampled data.

Channel Information (Channel Information)

The channel information or numerical monitor is displayed in the area where the screen setup menu is displayed. When the setup menu is displayed, closing the setup menu displays the channel information or numerical monitor.

- OFF: The channel information nor numerical monitor is displayed.
- Setting (Setting): The channel information is displayed. The following items are displayed. If the number of displayed channels increases, only some the items may be displayed.
 - When measuring voltage: V/div, input coupling, probe attenuation (type), bandwidth limit
 - When measuring temperature: Temperature/div, thermocouple type, bandwidth limit
 - When measuring strain: μ STR/div (or [mV/V]/div), measurement range, bandwidth limit
 - When measuring acceleration: Acceleration/div, gain, input coupling, bias
 - When measuring frequency: Value/div, measurement mode, preset
- (Monitor): The level indicator values of each channel are displayed in the numeric monitor. The numeric monitor update interval is approximately 0.5 seconds.



-
- On models with the power math option (/G05 option), you can set the instrument to display only the power analysis or harmonic analysis information in the channel information area ([numeric monitor mode](#)).
 - If the displayed content does not fit in the channel information display area, drag the display area up or down to scroll the screen to display the hidden content.
-

Channel Information Width (Channel Information Width)

Set the size of the channel information/numeric monitor display area.

- Full: Full-screen
- Narrow: Width of the setup menu (displayed at the setup menu position)
- Wide: Right half of the full screen

Manual Event (Manual Event)

Indicates the positions of manually input events. You can enter manual events only when SSD recording is in operation (only for low-speed sampling when dual capture is on in Scope mode). You can input manual events by applying a low edge to the event input terminal (EVNT). You can enter up to 100 events. For the specifications of the EXT I/O terminal, see section 5.6 in the *Getting Started Guide*, IM DL950-03EN.

Interpolation Method (Dot Connect)

In interpolation zones in the T-Y waveform display,* Xviewer can display waveforms by interpolating between sampled data points.

- * Interpolation zone refers to the condition in which a given number of sampled data points are not contained in the 10 divisions along the time axis. The number of data points that define the interpolation zone varies depending on the display record length and zoom factor.

You can set the interpolation method to one of the options below.

- **OFF (2k)**

Displays the data using dots without interpolation. When the display record length exceeds 2 kpoint, the instrument removes data until there are only 2 kpoint and displays two points on each vertical line. When the record length is less than 2 kpoint, all the points are displayed.

- **OFF (100k)**

Displays the data using dots without interpolation. When the display record length exceeds 100 kpoint, the instrument removes data until there are only 100 kpoint and displays 100 points on each vertical line. When the record length is less than 100 kpoint, all the points are displayed.

- **Sine Interpolation (Sine)**

Interpolates a sine curve between two points using the $(\sin x)/x$ function. This method is suitable for the observation of sine waves.

- **Linear Interpolation (Line)**

Linearly interpolates between two points.

- **Pulse Interpolation (Pulse)**

Interpolates between two points in a staircase pattern.

Outside of the Interpolation Zone

If the interpolation method is set to Sine, Line, or Pulse, the dots are connected vertically.

If the number of data points is 2002 or greater, the instrument determines the P-P compression values (the maximum and minimum sampled-data values in a given interval), and displays vertical lines (rasters) connecting each pair of maximum and minimum P-P compression values.

When the interpolation method is set OFF (2 k) or OFF (100 k), the instrument displays the acquired data without P-P compression by removing the data between fixed intervals.

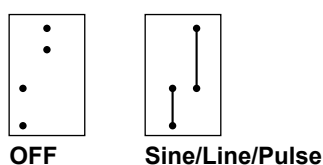

In the Interpolation Zone

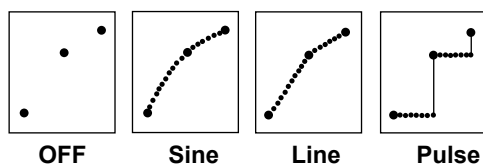

The interpolation method is set to Pulse when:

- The input signal is a logic signal.
- The acquisition mode is Envelope.



In SSD recording and roll mode display, if there are 100 points or more of data per division, the maximum and minimum values for every fixed data of acquisition data are displayed through linear interpolation.

Display Group Setup (Display Group Setup)

You can set the following items for the input channels (CH1 to CH16) of the modules installed in the slots, the real time math channels (RTmath1, RTmath16), and the computation channels (Math1, Math8).

Display Group Selection (Select Display Group)

Select the display group you want to set from the following:

- **Group #1 to #4 (Group #1 to #4)**

The channels assigned to the selected group are displayed in the mapping list.

By default, all input channels, real time math channels, and math channels are assigned to groups #1 to #4 in order (64 channels per group). You can change the channel assignments in the mapping list.

- **Analysis Group (Group Analysis)**

- Power (Power): The power analysis measurement function is displayed in the mapping list. You can change the display color of each channel in the mapping list.

- Harmonic (Harmonic): The harmonic analysis measurement function is displayed in the mapping list. You can change the display color of each channel in the mapping list.

Group #1 to #4 All Clear (Group #1 to #4 All Clear)

Clears all assigned channels for each display groups #1 to #4.

Auto Grouping (Auto Grouping)

Only the channels whose input (Input) is on are assigned to groups #1 to #4.

For sub channels, even if the channel input (Input) is set to ON, if the input coupling (Coupling) or input (Input) is set to OFF, the sub channels will be deleted from the mapping list when auto grouping is executed.

Mapping Mode (Mapping Mode)

Set how to map channels to the divided waveform screens on the mapping list.

- **Auto:**

The channels assigned to the mapping list are displayed in the order of the mapping list from the top of the divided waveform screen.

- **User**

The waveforms are arranged according to the user-specified [map \(Map\)](#).

Channel Assignment (CH)

You can assign any channels to the mapping list. However, the same channel cannot be assigned to the same group. The same channel can be assigned to multiple groups, but a single bit of a logic input module cannot be assigned to separate groups.

Display Color (Color)

You can set the display color of each of the waveforms to one of 16 colors.

You can assign all waveforms regardless of whether their displays are turned on.

- This can be set for each sub channel for the 16-CH temperature/voltage input, CAN bus monitor, CAN/CAN FD monitor, CAN & LIN bus monitor, SENT monitor, and 4-CH modules.
- Since logic input modules are not displayed as individual bits but are instead displayed as single channels, they can have only one color assigned to it.

Map (Map)

When the mapping mode is set to User, you can set the display position of each waveform relative to the top divided screen. You can assign all waveforms regardless of whether their displays are turned on.

- Selectable range: 1 to 16
If you set a number larger than the number of divided screens displayed, the waveform is displayed at the position relative to every specified number of divided screens. For example, if the number of divided screens displayed is 4, waveforms mapped to 1, 5, 9, and 13 will all be displayed in the top-most divided screen.
- This can be set for each sub channel for the 16-CH temperature/voltage input, CAN bus monitor, CAN/CAN FD monitor, CAN & LIN bus monitor, SENT monitor, and 4-CH modules.
- Since logic input modules are not displayed as individual bits but are instead displayed as single channels, they are assigned to the same screen.

Accumulation (Accumulate)

This is a setting available in Scope mode when dual capture is off. Usually, momentary waveform anomalies are difficult to recognize because the displayed waveform is updated whenever the trigger is activated. The accumulate feature makes the display time of the old waveform longer than the update interval and overlays the new waveform while leaving the old waveform. The accumulated waveforms are displayed with gradually decreasing intensity over a given time based on the specified number of counts.

- ON: Waveforms are accumulated.
- OFF: Waveforms are not accumulated.

Count (Count)

Set the number of times to accumulate. If you select Infinite, waveforms will be accumulated infinitely. Selectable range: 2 to 128 (2^n steps). The default setting is 16.

Clearing Accumulated Waveforms

Pressing CLEAR TRACE clears the accumulated waveforms.



- Automated measurement of waveform parameters and GO/NO-GO determination are performed on the most recent accumulated waveform.
- If you press START/STOP to stop waveform acquisition, accumulation stops. When you restart waveform acquisition, accumulation resumes from the condition that it was in when it was stopped.
- When Accumulate is set to ON, you cannot change the settings of the history feature.
- When Accumulate is set to ON, even if you change the display format, the waveforms that are currently on the screen are not cleared. To clear waveforms, press CLEAR TRACE.
- You cannot set accumulate to ON in the roll mode display.
- When you set accumulate to OFF, the accumulated waveforms are cleared. To redisplay the waveforms, use the history feature, and select the record number of the waveforms that you want to display. You can select only waveforms that have record numbers. You cannot display earlier waveforms.
- If the instrument does not trigger when the trigger mode is set to Normal, the waveform intensity is retained until the next time the instrument triggers.

Low-Speed Sampling Display Ratio (Low Speed Display Ratio)

This is a setting available in Scope mode when dual capture is on.

Set the percentage of the entire waveform display area that the low-speed sampling waveform will occupy.

- 0 %: The low-speed sampling waveform will not be displayed.
- 20 %: The low-speed sampling waveform will occupy 20 % of the waveform display area.
- 50 %: The low-speed sampling waveform will occupy half of the waveform display area.
- 100 %: Only the low-speed sampling waveform is displayed in the waveform display area.

6 X-Y Waveform Display

You can view the correlation between two waveform levels by assigning the level of one waveform to the X-axis (horizontal axis) and the level of the other waveform to the Y-axis (vertical axis). There are two X-Y waveform windows (Window1 and Window2), and you can display four pairs of waveforms in each window (for a total of eight pairs).

You can perform cursor measurements on the displayed X-Y waveforms. You can also observe T-Y (time axis) waveforms and X-Y waveforms simultaneously.

X-Y Window Selection (Window Select)

Select the item you want to configure from the two X-Y Windows (Window1 and Window2).

- **Display:** X-Y window display ON/OFF
- **Setup:** Settings of each X-Y waveform
- **Start Point/End Point:** Start point and end point settings

X-Y Window Display ON/OFF (Display)

Select whether to display the target X-Y window (Window1 or Window2).

- **ON:** The X-Y window is displayed.
- **OFF:** The X-Y window is not displayed.

X-Y Waveform Setup (Setup)

Up to eight X-Y waveform displays can be configured: XY1 to XY4 on Window1 and XY5 to XY8 on Window2. You can configure the following settings for each X-Y waveform.

X-Y Waveform Display ON/OFF (DISPLAY)

You can select whether to display each X-Y waveform (XY1 to XY4 and XY5 to XY8) in the X-Y window.

- **ON:** X-Y waveform is displayed.
- **OFF:** X-Y waveform is not displayed.

X Trace and Y Trace (X Trace and Y Trace)

For XY1 to XY4 and XY5 to XY8, you can select which waveforms to assign to the X and Y axes from the following options.

CH1 to CH16,¹ 16chTEMP/VOLT,² CAN,³ LIN,³ SENT,³ RTmath1 to RTmath8, Math1 to Math8

- 1 You can select the channel of an installed module. On a 4-CH module, select sub channel 1 or 2. You cannot select the input channel of a logic module.
- 2 When a 16-CH Temperature/Voltage Input Module is installed. Select 16chTEMP/VOLT and then a sub channel.
- 3 On models with the /VCE option when a CAN bus monitor, CAN/CAN FD monitor, CAN & LIN bus monitor, or SENT monitor module is installed. After you select CAN, LIN, or SENT, select a sub channel. This cannot be selected on a CAN bus monitor, CAN/CAN FD monitor, or CAN & LIN bus monitor module if the data type (Value Type) is set to Logic. On a SENT monitor module, S&C and Error Trigger sub channels cannot be selected.



- If the sample rates of the waveforms set on the X-axis and Y-axis are different, the waveform data of the slow sample rate is pulse-interpolated to display the X-Y waveform.
 - When dual capture is enabled, the high-speed sampling waveforms are used for the X-Y waveform.
 - Logic waveforms and event waveforms cannot be used to make X-Y waveforms.
-

Start Point and End Point (Start Point/End Point)

You can set the start and end points of the X-Y waveforms on the T-Y waveforms. You can set different start and end points for each X-Y window.

Selectable range: ± 5 divisions with the center of the T-Y waveform window taken to be 0 divisions.

- Scope mode: Set the positions in divisions.
- Recorder mode: When the time base is internal, set the positions in terms of the time (ddhmmss) corresponding to divisions. When the time base is external, set the positions in terms of points (0 to record length).

The start and end points are similar to the settable range of the cursor display position in cursor measurement. For details, see “Selectable Range of Cursor Positions.”

▶ [See here.](#)

Pen Marker (Pen Marker)

Select whether to display a pen marker on an X-Y waveform whose display is turned on. It shows the current sampled point of the waveform.

- ON: The pen marker is displayed.
- OFF: The pen marker is not displayed.

X-Y Waveform Cursor Measurement (Cursor)

Cursor Mode Setup (Mode)

Select whether to perform cursor measurements.

- OFF: Cursor measurement is not performed.
- ON: Cursor measurement is performed.

Cursor Type (Type)

The following types of X-Y waveform cursors are available.

- [Horizontal cursors \(Horizontal\)](#): Two horizontal cursors are used to measure vertical (Y-axis) values.
- [Vertical cursors \(Vertical\)](#): Two vertical cursors are used to measure horizontal (X-axis) values.
- [Marker cursors \(Marker\)](#): Four marker cursors that move on the waveform are used to measure waveform values.
- [Horizontal and vertical cursors \(H & V\)](#): Two horizontal cursors and two vertical cursors are used to measure vertical (Y-axis) and horizontal (X-axis) values.

Horizontal Cursors (Horizontal)

Two dashed lines (horizontal cursors) appear on the horizontal axis. You can measure the vertical (Y axis) value at the position of each horizontal cursor and measure the level difference between the horizontal cursors.

Measurement Source Waveform (Trace)

Set the measurement source waveform to one of the waveforms below.

XY1 to XY8

Cursor Movement (Cursor1/Cursor2)

Use Cursor1 and Cursor2 to move the cursors.

You can set in the range of -5 to $+5$ div from the center of the waveform display window. You can set them in 0.01 div steps.

Measurement Items (Item Setup)

You can measure the following vertical (Y axis) values at the cursor positions.

Y1	Vertical (Y axis) value at Cursor1
Y2	Vertical (Y axis) value at Cursor2
ΔY	Difference between the vertical (Y axis) values of Cursor1 and Cursor2

Vertical Cursors (Vertical)

Two dashed lines (vertical cursors) appear on the vertical axis. You can measure the horizontal (X axis) value at the position of each vertical cursor and measure the level difference between the vertical cursors.

Measurement Source Waveform (Trace)

Set the measurement source waveform to one of the waveforms below.

XY1 to XY8

Cursor Movement (Cursor1/Cursor2)

Use Cursor1 and Cursor2 to move the cursors.

You can set in the range of -5 to $+5$ div from the center of the waveform display window. You can set them in 0.01 div steps.

Measurement Items (Item Setup)

You can measure the following horizontal (X axis) values at the cursor positions.

X1	Horizontal (X axis) value at Cursor1
X2	Horizontal (X axis) value at Cursor2
ΔX	Difference between the horizontal (X axis) values of Cursor1 and Cursor2

Marker Cursors (Marker)

Four markers are displayed on the selected waveform. You can measure the level at each marker, the amount of time from the trigger position to each marker, and the level and time differences between markers.

Markers 1 to 4 (Target Marker)

Select the markers (Marker 1 to 4) you want to display. You can assign each marker (Marker 1 to 4) to separate waveforms.

Measurement Source Waveform (Trace)

Set the measurement source waveform to one of the waveforms below.

XY1 to XY8

Position (Position)

Set the position of the selected marker.

You can set in the range of -5 to +5 div from the center of the waveform display window. You can set them in 0.005 div steps.

Marker Shape (Marker Form)

Set the shape of the displayed marker to one of the options below.

- Mark: A mark
- Line: A crosshair

Measurement Items (Item Setup)

Marker cursors move on the waveform data. You can measure the following values at the markers.

X1	Horizontal (X axis) value at Marker1
X2	Horizontal (X axis) value at Marker2
X3	Horizontal (X axis) value at Marker3
X4	Horizontal (X axis) value at Marker4
Y1	Vertical (Y axis) value at Marker1
Y2	Vertical (Y axis) value at Marker2
Y3	Vertical (Y axis) value at Marker3
Y4	Vertical (Y axis) value at Marker4
T1	Time from the trigger position at Marker1
T2	Time from the trigger position at Marker2
T3	Time from the trigger position at Marker3
T4	Time from the trigger position at Marker4
$\Delta(T2-T1)$	Time difference between Marker1 and Marker2
$\Delta(T3-T1)$	Time difference between Marker1 and Marker3
$\Delta(T4-T1)$	Time difference between Marker1 and Marker4

Horizontal and Vertical Cursors (H & V)

You can display the horizontal and vertical cursors simultaneously and measure vertical (Y axis) and horizontal (X axis) values.

Measurement Source Waveform (Trace)

Set the measurement source waveform to one of the waveforms below.

XY1 to XY8

Moving the Cursors (V Cursor1/V Cursor2, H Cursor1/H Cursor2)

Use the vertical cursors (V-Cursor1, V-Cursor2) and horizontal cursors (H-Cursor1, H-Cursor2) to move the cursors.

You can set in the range of -5 to $+5$ div from the center of the waveform display window. You can set them in 0.01 div steps.

Measurement Items (Item Setup)

You can measure the following horizontal (X axis) and vertical (Y axis) values at the cursor positions.

Horizontal Axis (X axis)

X1	Horizontal (X axis) value at V-Cursor1
X2	Horizontal (X axis) value at V-Cursor2
ΔX	Difference between the horizontal (X axis) values of V-Cursor1 and V-Cursor2
$\Delta X/\Delta Y$	Amount of change on the horizontal axis corresponding to the amount of change on the vertical axis

Vertical Axis (Y axis)

Y1	Vertical (Y axis) value at H-Cursor1
Y2	Vertical (Y axis) value at H-Cursor2
ΔY	Difference between the vertical (Y axis) values of H-Cursor1 and H-Cursor2
$\Delta Y/\Delta X$	Amount of change on the vertical axis corresponding to the amount of change on the horizontal axis

Display Ratio of the Main Window (Main Ratio)

▶ [See here.](#)

Window Layout (Window Layout)

Set the window layout when two X-Y windows are displayed or when a combination of two windows—an X-Y window and another window (zoom window, FFT window, or harmonic window)—are displayed.

This is synchronized with the setup menu (Window Layout) of the zoom window, FFT window, and harmonic window.

- Side: Horizontal
- Vertical: Vertical (valid only when Main Ratio is set to 0 % when multiple X-Y windows are displayed)

Combine Display (Combine Display)

Choose whether to combine the two X-Y windows into one window.

- ON: The windows are combined.
- OFF: The windows are not combined.

The two X-Y Windows (Window1 and Window2) can be consolidated in a single window.

If the X-Y window and the zoom window or FFT window are displayed at the same time, only one X-Y window can be displayed. You can display all X-Y windows by combining the windows.

- ON: The windows are consolidated.
- OFF: The windows are not consolidated.

Interpolation Method (Dot Connect)

In interpolation zones in the X-Y waveform display,* Xviewer can display waveforms by interpolating between sampled data points.

* Interpolation zone refers to the condition in which a given number of sampled data points are not contained in the X-Y waveform display. The number of data points that define the interpolation zone varies depending on the display record length.

You can set the interpolation method to one of the options below.

- **OFF**
Displays the data using dots without interpolation.
- **Linear Interpolation (Line)**
Linearly interpolates between two points.

Diagram Explaining the Interpolation Method

▶ [See here.](#)

Number of Data Points to Use for Waveform Display (Decimation)

In the X-Y waveform display, the instrument displays the acquired data by removing the data between fixed intervals. You can set the number of points to use to display waveforms to one of the options listed below.

2 k, 100 k

Detailed Explanation

▶ [See here.](#)



- To zoom in or out on an X-Y waveform, change the upper and lower limits (Upper and Lower) of the channel that you want to zoom, or change the vertical zoom (V Zoom).
 - On voltage input modules, to change the displayed position of an X-Y waveform, change the positions of the channels that it is based on.
-

Clearing Waveforms at Acquisition Start (Trace Clear on Start)

Choose whether to clear the current X-Y waveforms when waveform acquisition is started with the START/STOP key.

- ON: X-Y waveforms are cleared.
- OFF: X-Y waveforms are not cleared.

7 Zooming In on or Out of Waveforms

You can magnify displayed waveforms along the time axis. You can also specify which channel you want to zoom in on. You cannot zoom if the number of displayed points on the screen is less than or equal to 100.

Scope Mode

- When dual capture is off, the zoomed waveforms of two locations can be displayed simultaneously (dual zoom).
- When dual capture is on, you can zoom the low-speed and high-speed sample waveforms.

Example of the Dual Zoom Display

• When dual capture is off

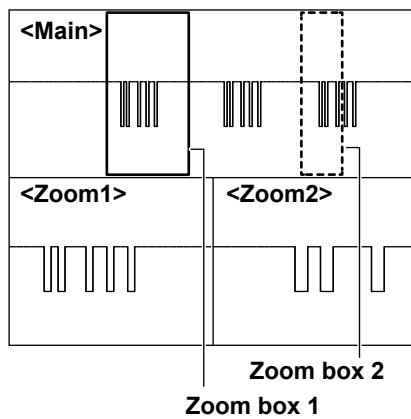

• When dual capture is on

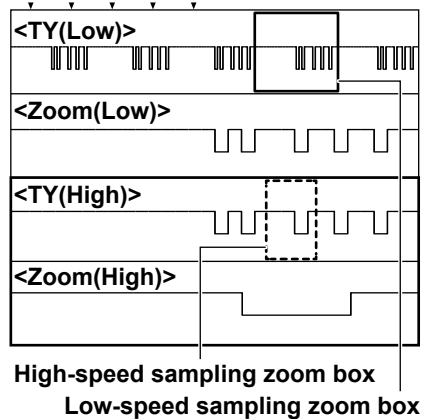

Recorder Mode

- On the main window (TY), the waveforms in the range set in the waveform display section of the captured waveforms are displayed. ▶ [See here.](#)
- You can zoom one location of the waveform displayed on the main window (TY).

Example of the Zoom Display

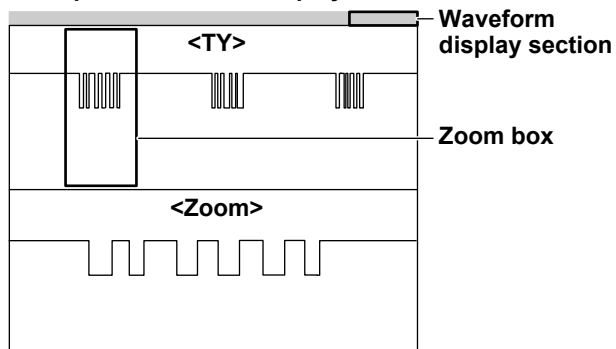

If zoom waveforms and main waveforms are displayed at the same time, a zoom box appears in the normal waveform window so that you can check the zoom position.

When dual capture is off in Scope mode, the box enclosed by the solid line is the zoom box for Zoom1 and the box enclosed by the dashed line is the zoom box for Zoom2.

Vertical Zoom

You can set the zooming of the displayed waveforms in the vertical direction using the menu displayed when you press the CH key. ▶ [See here.](#)

Zoom Window Selection (Window)

This is a setting available in Scope mode. Select the target zoom window.

- Zoom1/Zoom2: When dual capture is off, select which zoom window, Zoom1 or Zoom2, you want to configure. The target zoom box is displayed in blue.
- Low-speed Z1/high-speed Z2 (Low Speed Z1/High Speed Z1): When dual capture is on, select which waveform, low-speed sampling or high-speed sampling, you want to configure.

Zoom Window Display ON/OFF (Display)

Set whether to display each of the target zoom windows.

- ON: The zoom window is displayed.
- OFF: The zoom window is not displayed.

Zoom Source Window (Zoom2 Source)

This is a setting available in Scope mode when dual capture is off. Select the waveforms that you want to enlarge in the Zoom2 window. You can set this when you set the target to Zoom2 when the Zoom1 and Zoom2 displays are on.

- Main (Main): Main window waveforms
- Zoom1: Zoom1 window waveforms

Zoom Factor (MAG knob)

Use the MAG knob to set the zoom factor. You can set a horizontal zoom factor for each of the target zoom windows. The zoom-window time scale changes automatically based on the specified zoom factor.

Selectable Range

From 2x (Scope mode) or 1x (Recorder mode) the time scale (TIME/DIV) of the normal waveform window until the number of data points in the zoom window reaches 10 points/div. Waveforms are magnified around the centers of the zoom boxes.



- When an external clock signal is being used as the time base, you can select one of the following magnifications. You can select any magnification up to the point where the number of data points in the zoom window reaches 10 points per div.
Up to 1000000 in 1-2.5-5 steps (×2, ×2.5, ×5, ×10, ×25, ×50, ×100, ×250, ×500, ×1000, ×2500, and so on)
- You may not be able to set the zoom factor to the upper limit when SSD recording is in progress. If you want to view the waveform by increasing the zoom factor, zoom after recording is finished.

What the MAG Knob and Zoom POSITION Knob Control

Pressing the MAG knob or zoom POSITION knob changes what the MAG knob or POSITION knob controls depending on the operation mode and causes the Z1 or Z2 indicator on the front panel to illuminate.

Operation Mode	dual capture	Z1	Z2
Scope Mode	OFF	Zoom1 ¹	Zoom2 ¹
	ON	Low-speed zoom	High-speed zoom
Recorder Mode	—	Waveform display section ²	Zoom

- 1 The target zoom box is displayed in blue. You can use the zoom link feature. ► [See here.](#)
- 2 Select the range to display on the main window. ► [See here.](#)

Zoom Link

This is a feature available in Scope mode when dual capture is off.

When both Zoom1 and Zoom2 displays are ON, you can move the zoom positions while retaining the positional relationship between the two zoom boxes by pressing the MAG knob or Zoom POSITION knob to turn on both the Z1 and Z2 indicators. Likewise, you can also adjust the zoom factors while retaining the relationship between the two zoom factors.

Zoom Position (Zoom Position*) (zoom POSITION knob)

Use the zoom POSITION knob or jog dial to set the zoom position. You can also enter the position from the numeric keypad by tapping the menu item. Taking the horizontal center of the normal waveform window to be 0 divisions, set the center position of the zoom boxes in the range of -5 to +5 divisions.

* When dual capture is off, the menu name will be Zoom1 or Zoom2.

What the MAG Knob and Zoom POSITION Knob Control

▶ [See here.](#)

Zoom Link

▶ [See here.](#)

Setting the Waveform Display Section in Recorder Mode

This is a setting available in Recorder mode.

Set the range (waveform display section) to be displayed on the main window (TY) from the entire acquisition time or recording time in Recorder mode.

Time Setting of the Waveform Display Section

You can set the time of the waveform display section by turning the MAG knob while the Z1 indicator is turned on. The time scale of the main window changes automatically according to the specified waveform display section time.

Selectable Range

From the [acquisition time or the recording time](#) setting until the number of data points in the waveform window becomes 10 points/div

Moving the Waveform Display Section

You can move the waveform display section by turning the zoom POSITION knob while the Z1 indicator is turned on.

The waveform section is the box enclosed by a solid line on the acquisition/record time bar.

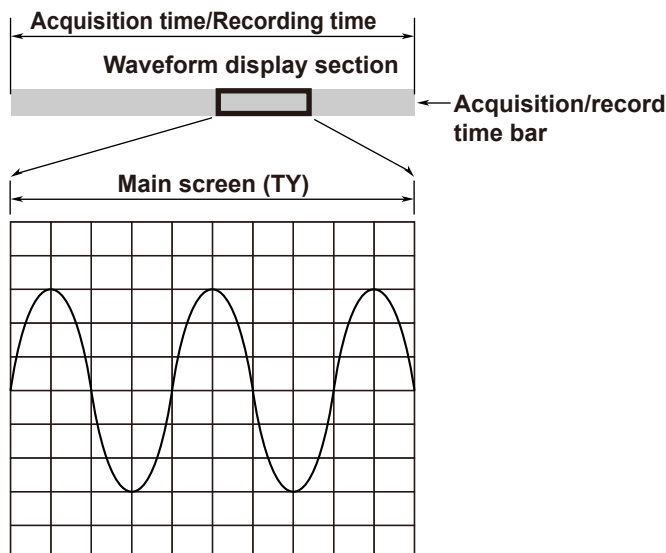

In Recorder mode, the Z1 indicator on the front panel is lit even when the zoom window is hidden. You can set the waveform display section by controlling the MAG knob or zoom POSITION knob in this condition.

If you want to set the waveform display section when a zoom window is displayed, press the MAG knob or zoom POSITION knob to turn off the Z1 indicator first.

Display Format (Format*)

Select how to display the zoom windows from one of the options listed below. If you select a number, the zoom windows are divided evenly, and waveforms are displayed within the divisions.

- Main (Main): The same display format as the normal waveform window (main window) of each display group
- 1, 2, 3, 4, 5, 6, 8, 12, 16: The window is broken up into the specified number of divisions.
- * When dual capture is off, Zoom1 or Zoom2 will be added to the menu names.

Moving the Zoom Position to the Right Edge (Move to Front*)

This is a setting available in Scope mode. It moves the zoom box position to the right edge of the screen (most recent data position). When waveforms scroll from right to left, as in the roll mode display, you can zoom in on the waveform at the right edge.

- * When dual capture is off, Zoom1 or Zoom2 will be added to the menu names.



- When dual capture is off, this setting is not displayed in the Zoom2 setup menu when the original waveform displayed in the Zoom2 window is set to Zoom1.
 - When dual capture is on, this setting is not displayed in the high-speed sampling setup menu.
-

Display Ratio of the Main Window (Main Ratio)

Set the percentage of the entire waveform display area that the normal waveform window (main window) will occupy. When dual capture is enabled in Scope mode, set the display ratio of the main window separately for low-speed sampling and high-speed sampling.

This is synchronized with the setup menu (Main Ratio) of the X-Y window, FFT window, and harmonic window. It is not synchronized with the low-speed sampling setup menu (Main Ratio) of the dual capture.

- 50 %: The main window will occupy the top half of the waveform display area.
- 20 %: The main window will occupy the top 20 % of the waveform display area.
- 0 %: The normal waveform window (main window) is not displayed.



When you zoom the low-speed sampling waveform of dual capture, if the low-speed sampling display ratio (Low Speed Display Ratio) on the DISPLAY menu is set to 20 %, the display will be as follows:

- 50 %, 20 %: The low-speed sampling waveform display area is divided into left and right halves, and the zoom window is displayed in the right half. The main window display ratio cannot be changed.
 - 0 %: Only the zoom window is displayed.
-

Window Layout (Window Layout)

Set the window layout when two zoom windows are displayed (only when dual capture is disabled in Scope mode) or when a combination of two windows—a zoom window and another window (X-Y window, FFT window, or harmonic window)—are displayed.

This is synchronized with the setup menu (Window Layout) of the X-Y window, FFT window, and harmonic window.





- Side: Horizontal
- Vertical: Vertical (valid only when Main Ratio is set to 0 % when multiple X-Y windows are displayed)



This setting is not available because the only windows that can be displayed for low-speed sampling of dual capture are one main window and one zoom window.

Auto Scrolling (Auto Scroll)

This feature automatically moves the zoom position in the specified direction (auto scroll). You can view the zoom waveform and stop scrolling at the appropriate position. When dual capture is on in Scope mode, you can auto-scroll only the low-speed sampling waveforms (Low Speed Auto Scroll).

	Zooms in on the left edge of the Main window
	Zooms in on the right edge of the Main window
	Starts scrolling to the left
	Starts scrolling to the right
	Stops scrolling

Target (Target)

This is a setting available in Scope mode when dual capture is off. Set the auto scroll target to Zoom1 or Zoom2. You can set this when the Zoom1 and Zoom2 displays are turned on.

Speed (Speed)

You can select the auto scrolling speed.

Selectable range: 1 to 10. The default setting is 4.

Waveforms That Are Zoomed (Allocation)

The waveforms of the channels whose check boxes are selected in the allocation window and whose inputs are turned on are displayed in the zoom window.

Change the Range for Performing Automated Measurement of Waveform Parameters (Fit Measure Range)

The range for automated measurement of waveform parameters is aligned with the following zoom range. This applies even when automated measurement of waveform parameters is disabled.

Scope Mode

• When dual capture is off

- Fit to Zoom1 (Fit to Zoom1): The range is aligned with the Zoom1 zoom range.
- Fit to Zoom2 (Fit to Zoom2): The range is aligned with the Zoom2 zoom range.
- Fit Area2 to Zoom1 (Zoom1 to Area2 match): The Area2 measurement range is aligned with the Zoom1 zoom range.
- Fit Area2 to Zoom2 (Zoom2 to Area2 match): The Area2 measurement range is aligned with the Zoom2 zoom range.

• When dual capture is on

- Fit high-speed (Fit High Speed): The automated measurement range of high-speed sampling is aligned with the zoom range of high-speed sampling.
- Fit low-speed (Fit Low Speed): When low-speed sampling measurement mode is on, the automated measurement range of low-speed sampling is aligned with the zoom range of low-speed sampling.

Recorder Mode

- Fit to Zoom (Fit to Zoom): The range is aligned with the zoom range.
- Fit Area2 to Zoom (Zoom to Area2 match): The Area2 measurement range is aligned with the zoom range.

8 Searching Waveforms

You can search the displayed waveforms for locations that match the specified conditions. You can zoom-in on the detected locations. You can search the waveforms within the specified search range up to 10 Gpoint.

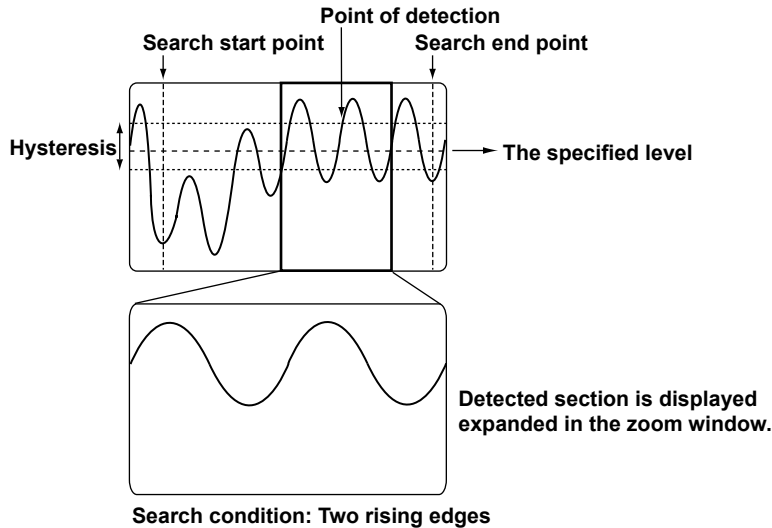

- In scope mode, the Zoom1 window is displayed automatically when you open the SEARCH menu.
- In recorder mode, the Zoom1 window is not displayed automatically when you open the SEARCH menu.

Search Type (Type)

Set the search type to one of the options below.

- **Edge (Edge)**: The instrument searches for edges.
- **Event (Event)**: The instrument searches for an event.
- **Logic Pattern (Logic Pattern)**: The instrument searches for logic patterns. This setting is valid only for logic signals. This setting is only valid for logic signals.
- **Time (Time)**: The instrument searches for a time.

Edge Search (Edge)

Search for positions where the rising or falling slope of the specified waveform passes through the specified level.

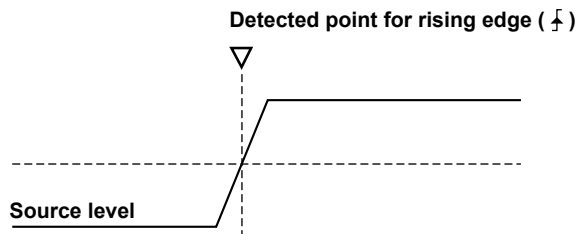

Search Conditions (Setup)

Set the search conditions, such as the waveforms to search, judgment level, polarity, hysteresis, count, and bit settings.*

* Only on the channel of a logic module

8 Searching Waveforms

Search Source Waveform (Trace)

Select the waveforms to search from the options listed below.

CH1 to CH16,¹ RTmath1 to RTmath16, 16chTEMP/VOLT,² CAN,³ LIN,³ SENT,³ Power,⁴ Harmonic⁴

- 1 You can select the channel of an installed module. On a 4-CH module, select sub channel 1 or 2.
- 2 When a 16-CH Temperature/Voltage Input Module is installed. Select 16chTEMP/VOLT and then a sub channel.
- 3 On models with the /VCE option when a CAN bus monitor, CAN/CAN FD monitor, CAN & LIN bus monitor, or SENT monitor module is installed. After you select CAN, LIN, or SENT, select a sub channel.
- 4 When power math (/G05 option) is on. Select Power or Harmonic and then a measurement function. Power math waveforms saved using SSD recording cannot be searched.

Determination Level (Level)

Set the level used to detect the rising or falling edges of the waveforms. You can set the level to a value within the 10 divisions of the screen. The resolution at which you can set the level varies depending on the module.

Polarity (Polarity)

Select which polarity will be used to detect edges from the options listed below.

- \uparrow : Rising
- \downarrow : Falling
- \updownarrow : Rising or falling

Hysteresis (Hysteresis)

You can set a range (hysteresis) within which level changes are not treated as edges. You can set the hysteresis to one of the settings below. The hysteresis widths vary depending on the input module.

- \wedge : Low hysteresis
- ∇ : Medium hysteresis
- $\nabla\wedge$: High hysteresis

Bit Settings (Bit Setting)

For each bit from Bit1 to Bit8, you can select which polarity will be used to detect edges from the options listed below. This setting is available only for the channels of logic modules. The instrument searches based on the OR of each bit.

- \uparrow : Rising
- \downarrow : Falling
- \updownarrow : Rising or falling
- -: The signal is not used as a trigger condition.

Count (Count)

Set the number of times the specified edge (\uparrow , \downarrow , or \updownarrow) must repeat. You can select a number from 1 to 1000000.

The detected point is the point at which the search conditions are met the specified number of times. For example, if the count is set to 5, when five points that meet the search conditions are found, the fifth point becomes the detected point.

Search Waveform Window (Result Window)

This is a setting available in Scope mode. Select the zoom window (Zoom1 or Zoom2) to display an enlarged view of the detected point specified with a detected point number (Pattern No.).

You can make this selection only when both Zoom1 and Zoom2 displays are turned on and dual capture is off.



If Zoom1 and Zoom2 displays are both off and you press SEARCH, the Zoom1 display turns on.

Detected Point Number (Pattern No.)

Specify the number of the detected point (location where the search conditions are met) to display in the zoom window. The maximum detected point number is 1000. If the search does not yield any results, "No Match" appears.

Search Range (Start Point/End Point)

Set the search start and end points (Start Point and End Point). The default settings are -5 div to $+5 \text{ div}$.

Selectable range: -5 div to $+5 \text{ div}$

- Scope mode: Set the positions in divisions.
- Recorder mode: When the time base is internal, set the positions in terms of the time (ddhhmmss) corresponding to divisions. When the time base is external, set the positions in terms of points (0 to record length).

The start and end points are similar to the settable range of the cursor display position in cursor measurement. For details, see "Selectable Range of Cursor Positions."

▶ [See here.](#)

Executing a Search (Execute)

The instrument searches for positions where the specified search conditions are met. Then, the instrument displays the waveform expanded in the zoom window with the detected point that corresponds to the number you specify at the center.

Up to 1000 points can be detected.

The instrument searches for positions where the specified search conditions are met from the left edge of the search range. Up to 1000 points can be detected. When the point is found, the instrument finishes searching and displays the detected point as follows.

- Scope Mode
The detected point is displayed expanded in the Zoom1 window.
- Recorder Mode
The waveform display section moves so that the detected point is at the center. When zoom display is turned on, the detected point is displayed expanded at the center.

If you execute searching again in this condition, the instrument uses the detected point as the starting point and searches to the right.

If you execute searching numerous times and several detected points are found, you can specify a pattern number to display the corresponding detected point at the center.

Edge Search Determination

If the peak is below the upper limit of the hysteresis immediately after a rising edge or above the lower limit of the hysteresis immediately after a falling edge, the instrument will not count the edge.

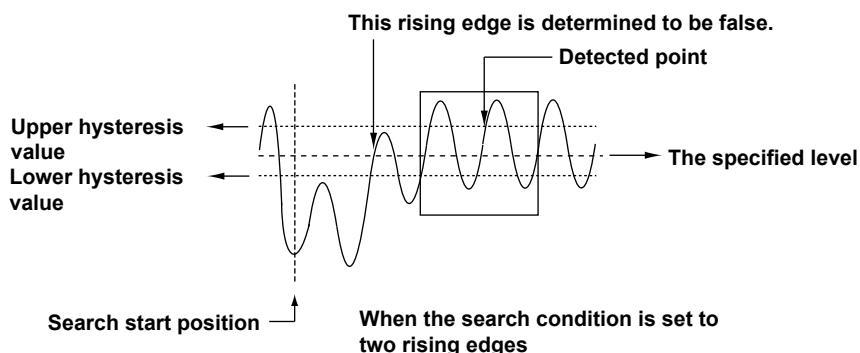

Event Search (Event)

Search is performed using the manual event's event number entered at the time of measurement.

Event Number (Select Number)

Select the event number that you want to search for. When the trigger mode is auto, event search is performed only on the event numbers remaining on the display screen.

Selectable range: 1 to 100 (maximum number of input events)

Search Waveform Window (Result Window)

▶ [See here.](#)

Executing a Search (Execute)

The instrument displays the waveforms of the area around the selected event number expanded in the zoom window.

▶ [See here.](#)

Logic Pattern Search (Logic Pattern)

The instrument searches for the specified logic pattern. This setting is only valid for logic modules.

Search Conditions (Setup)

Set the following search conditions: the waveforms to search, bit settings, and count.

Search Source Waveform (Trace)

Select the waveforms to search from the options listed below.

CH1 to CH16*

* You can select only the following channels.

- Channels of logic modules
- Sub channels of CAN bus monitor, CAN/CAN FD monitor, or CAN & LIN bus monitor modules whose data types are set to Logic.
- S&C and Error trigger sub channels of SENT monitor modules

Bit Settings (Bit Setting)

To set the logic signal pattern that you want to detect, set the signal states for Bit1 to Bit8. The instrument searches based on the AND of each bit.

- H: High level
- L: Low level
- X: The state of the bit is not used as a condition.

Count (Count)

Set the number of times the specified pattern must repeat.

▶ [See here.](#)

Search Waveform Window (Result Window), Detected Point Number (Pattern No.)

Search Range (Start Point/End Point, Executing a Search (Execute))

▶ [See here.](#)

Time Search (Time)

Search for a specific year, month, day, and time.

Search Conditions (Setup)

Specify the time that you want to search for.

Set the year (Year), month (Month), day (Day), hour (Hour), minute (Minute), second (Second), and microsecond (μ Second).

Search Waveform Window (Result Window)

▶ [See here.](#)

Executing a Search (Execute)

The instrument displays the waveform expanded in the zoom window at the specified time.

▶ [See here.](#)

Notes about Searching Waveforms

- You cannot search during data acquisition.
- The search results are invalid after you:
 - Start data acquisition.
 - Change the settings.
- If you invert or change the offset voltage of a waveform that has been selected as a waveform to search, the search is performed on the new waveform.

Notes about Using the 16-CH Temperature/Voltage Input Module (720221)

▶ [See here.](#)

9 History Waveform Display/Search (Scope mode only)

Acquisition memory stores waveforms that are displayed on the screen and waveform data that have been acquired in the past. The history feature allows you to display or search past waveforms (history waveforms). When dual capture is on, the acquired high-speed sampling waveforms can be displayed as a list or displayed by specifying a number in the same way as history waveforms. ► [See here.](#)
You can perform the following operations on history waveforms:

Displaying History Waveforms

You can display any single waveform or display all waveforms (and highlight only the specified waveform). You can also list the timestamps (the times at the time references) of all history waveforms.

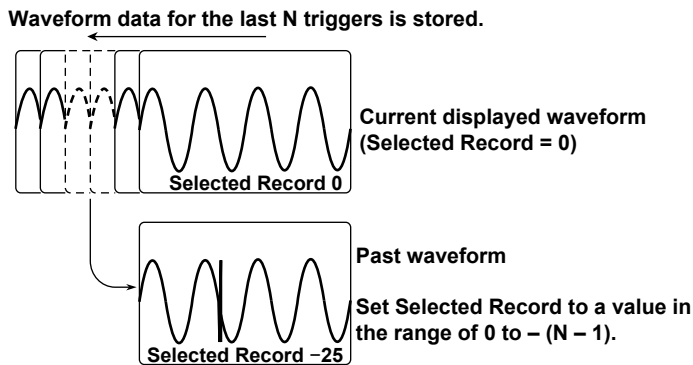

History Waveform Search

You can search for waveforms that meet the specified conditions, display the detected history waveforms, and list the timestamps of the waveforms.

Zone Search

You can search the history waveforms for waveforms that pass (or not pass) through a specified search zone from.

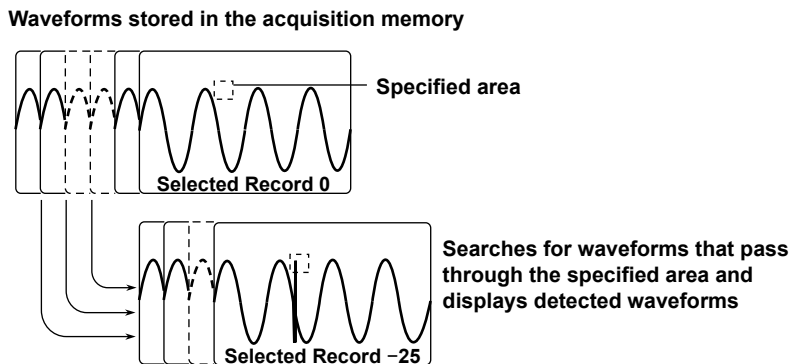

9 History Waveform Display/Search (Scope mode only)

Parameter Search

You can search the history waveforms for waveforms that meet (or not meet) the specified search parameter conditions.

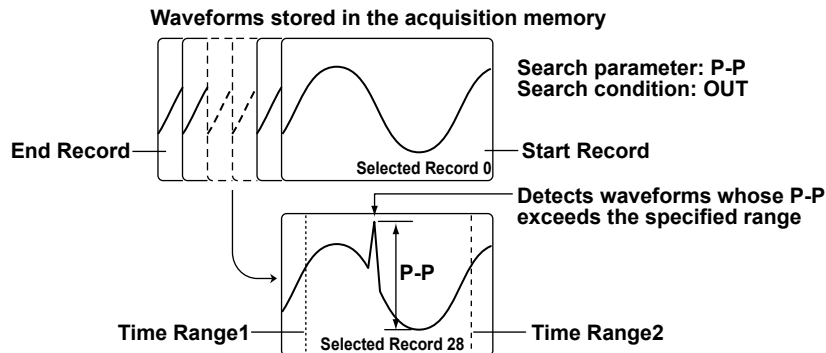

History Waveform Search Range

The search range is from Start Record to End Record.

Search Method

Searching is performed in order from the most recent waveform.

Calculation, Cursor Measurement, Automated Measurement, Statistical Processing, and FFT

You can perform calculations,* cursor measurement, automated measurement of waveform parameters, or FFT analysis* on the history waveform that you specified with Selected Record. You can also calculate statistics of automatically measured values on all history waveforms.

* If the waveform is acquired with the average setting (Average Setup) set to something other than OFF (excluding the math cycle), the averaged math waveform is displayed, so changing the Selected Record does not change the math waveform.

Displaying and Analyzing XY Waveforms

You can display XY waveforms and perform analysis on the history waveform you specified with Selected Record. If the display mode is set to All, XY waveforms of all history waveforms are displayed.

Display Mode (Display Mode)

Selects how history waveforms are displayed.

- One waveform (1 Record): Only the waveform that corresponds to the selected record number is displayed.
- All waveforms (All Record): All history waveforms from the specified start (Start Record) to stop (End Record) number are overlaid. All waveforms other than the highlighted one are displayed in an intermediate color.
- Averaged waveform (Average Record): Linear averaging is performed on all history waveforms from the specified start (Start Record) to stop (End Record) number, and the results are displayed as a single waveform.



To display averaged waveforms, waveforms need to be acquired with a set record length that allows at least 61 history waveforms to be acquired. For details on the relationship between the set record length and the number of history waveforms that can be acquired, see appendix 5 in the *Getting Started Guide*, IM DL950-03EN.

Highlighting (Selected Record)

The latest history waveform is assigned the record number zero, and older waveforms are assigned numbers in descending order (-1, -2, -3, and so on). The waveform and history map list's timestamp that correspond to the record number you specify here are highlighted.

Selectable range: 0 to -(the number of waveform acquisitions - 1)

Maximum Number of Waveform Acquisitions

(Maximum number of history waveforms that can be stored in the acquisition memory)

The number of history waveforms that can be retained depends on the set record length, the presence or absence of memory options, and the number of channels for acquiring waveforms as follows. For details, see appendix 5 in the *Getting Started Guide*, IM DL950-03EN.

Set Record Length (Points)	Number of Waveforms (when measuring with two channels maximum)		
	No options (1 Gpoint)	/M1 option (4 Gpoint)	/M2 option (8 Gpoint)
10 k	5000	5000	5000
25 k	5000	5000	5000
50 k	4093	5000	5000
100 k	2045	5000	5000
250 k	1021	4093	5000
500 k	509	2045	4093
1 M	253	1021	2045
2.5 M	125	509	1021
5 M	61	253	509
10 M	31	125	253
25 M	15	61	125
50 M	7	31	61
100 M	3	15	31
250 M	1	7	15
500 M	1	3	7
1 G	—	1	3
2 G	—	1	1
4 G	—	—	1

— This record length cannot be set.

Display Range (Start and End Record)

Using record numbers, set the range of history waveforms to display when the display mode is set to All or Average.

Selectable range: 0 to -(the number of waveform acquisitions - 1)

List of History Waveforms (List)

The history waveform record numbers and the timestamps when the waveforms were acquired are listed.

History Waveform Search Mode (Search Mode)

You can search the history waveforms for waveforms that meet the specified conditions when waveform acquisition is stopped.

- OFF: Searching is not performed. All history waveforms are displayed.
- Zone (Wave Zone): Searches the history waveforms for waveforms that pass (or not pass) through a specified search zone from.
- Parameter (Parameter): Searches the history waveforms for waveforms that meet (or not meet) the specified search parameter conditions.

Search Conditions for Zone Searching (Search Setup)

You can register four search zones in Zone1 to Zone4. You can set search conditions, source waveforms, and search window ranges for Zone1 to Zone4, separately.

Search Zone (Zone Select)

Select the search zone you want to configure from zone 1 to 4 (Zone1 to Zone4).

Search Condition (Condition)

- IN: Searches for waveforms that pass through the specified search window.
- OUT: Searches for waveforms that do not pass through the specified search window.
- OFF: Waveform searching is not performed.

Source Waveform (Source)

Searches the waveform specified with Source. The channels that you can specify are CH1 to CH16 and RTmath1 to RTmath16. Waveforms of channels other than search source channels are displayed. However, you cannot search the waveforms of a logic module, 16-CH Temperature/Voltage Input Module, CAN Bus Monitor Module, CAN/CAN FD Monitor, CAN & LIN Bus Monitor, SENT Monitor Module, or power math (/G05 option).

Upper and Lower Limits of Search Window (Upper/Lower)

The selectable range ± 5 divisions. The resolution is 0.01 divisions.

You cannot set the upper limit to a value less than the lower limit.

Left and Right Boundaries of Search Window (Left/Right)

The selectable range ± 5 divisions. The resolution is 10 divisions/display record length.

You cannot set the left boundary to a value greater than the right boundary.

Search Logic (Logic)

- AND: Searches for waveforms that meet all of the conditions of zones 1 to 4 (Zone1 to Zone4).
- OR: Searches for waveforms that meet any of the search conditions of zones 1 to 4.

Search Conditions for Waveform Parameter Searching (Search Setup)

You can register four search parameters in Param1 to Param4. You can set search conditions, source waveforms, waveform parameters, and search ranges for Param1 to Param4, separately.

Search Parameter (Parameter Select)

Select the search parameter you want to configure from parameters 1 to 4 (Param1 to Param4).

Search Condition (Condition)

- IN: Searches for waveforms whose specified parameter is within the specified range (upper and lower limits).
- OUT: Searches for waveforms whose specified parameter is outside the specified range (upper and lower limits).
- OFF: Waveform searching is not performed.

Source Waveform and Parameter Selection (Source)

• Source Waveform (Trace)

Select the search source waveform. However, you cannot search the waveforms of a 16-CH Temperature/Voltage Input Module, CAN Bus Monitor Module, CAN/CAN FD Monitor, CAN & LIN Bus Monitor, SENT Monitor Module, or power math (/G05 option).

• Parameter (Item)

Select a single parameter from the waveform parameters that are automatically measured.

Upper and Lower Limits of Search Condition (Upper/Lower)

Set the range for determining the search condition IN/OUT state.

Search Logic (Logic)

- AND: Searches for waveforms that meet all of the conditions of parameters 1 to 4 (Param1 to Param4).
- OR: Searches for waveforms that meet any of the search conditions of parameters 1 to 4.

Parameter Measurement Time Period (Time Range1/Time Range2)

Select the measurement time period of the specified parameter.

Selectable range: -5 div to +5 div

Default settings: -5 div (time range 1), +5 div (time range 2)

The start and end points are similar to the settable range of the cursor display position in cursor measurement.

For details, see "Selectable Range of Cursor Positions."

▶ [See here.](#)

Executing a Search (Execute)

Searches for waveforms that meet the specified search conditions and displays only the waveforms and timestamps that are detected according to the display mode.

Clearing History Waveforms (Clear History)

Clears all history waveforms.

Notes on Using the History Feature

- You can start waveform acquisition when the History menu is displayed. However, you cannot change the history feature settings while waveform acquisition is in progress.
- When the acquisition mode is set to Average, you cannot use the history feature.
- You cannot use the history feature during SSD recording.
- If you stop waveform acquisition, even if one complete screen's worth of waveform data has not been acquired, the waveform at which the trigger occurred is displayed as a single history waveform.
- If you stop waveform acquisition and then start it again without changing the waveform acquisition conditions, the waveform data continues to be stored in the acquisition memory.
- If you change the waveform acquisition conditions and start waveform acquisition, the past data stored in the acquisition memory is cleared.
- To display averaged waveforms, waveforms need to be acquired with a set record length that allows at least 61 history waveforms to be acquired. For details on the relationship between the set record length and the number of history waveforms that can be acquired, see appendix 5 in the *Getting Started Guide*, IM DL950-03EN.
- The settings are restricted so that the following relationship is retained: Last record (End Record) \leq Selected Record \leq first record (Start Record).
- When you load waveform data from the specified storage device, history waveforms up to that point are cleared. The loaded waveform data is placed in record number zero. If you load a file containing multiple history waveforms, the latest waveform is placed in zero, and earlier waveforms are placed in order to record numbers 1, 2, and so on.
- Computation and automated measurement of waveform parameters are performed on the waveform of the record number specified by Selected Record. You can analyze old data as long as you do not overwrite the acquisition memory contents by restarting waveform acquisition. If Display Mode is set to Average Record, analysis is performed on the averaged waveform.

9 History Waveform Display/Search (Scope mode only)

- The times that are listed are the times at the time references. When the waveform display is in update mode, the time references are the trigger times. Furthermore, these times vary as indicated below depending on the trigger mode.

Trigger Mode	Condition	Time Displayed in the List
Auto/Auto Level	Roll mode	Stop time
Single	Roll mode, no trigger	Stop time
On Start	—	Start time

- When all the waveforms are displayed, if a large number of records are selected, it may take time for them to be displayed completely. When the display is not complete,  appears in the center of the screen. If you want to stop the operation, set Display Mode to 1 Record.
- History waveforms are cleared when you turn the power off.

Displaying High-Speed Sampling Waveforms of Dual Capture

You can view the timing of acquiring the high-speed sampling waveform by the event mark displayed at the top of the low-speed sampling waveform display area. The color of the event mark for the high-speed sampling waveform displayed on the screen is reversed.

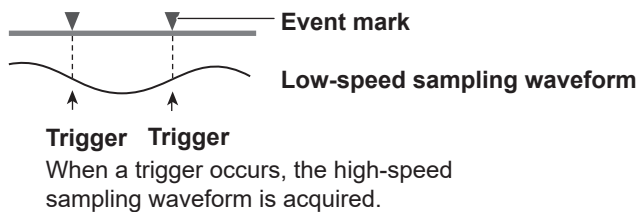

Display Number of the High-Speed Sampling Waveform (Selected Record)

You can display a waveform by selecting the number of high-speed sampling waveforms. The trigger time of the selected waveform is displayed at the lower left outside the waveform display area.

When Capture Mode Is Auto

The numbers you can select varies as follows. You can set a number to display the waveform when waveform acquisition is stopped.

0, -1, -2, ...

0: The latest waveform; 1: The waveform that was captured before the Current waveform; 2: The waveform that was captured two waveforms before the Current waveform.

When Capture Mode Is On Start

The numbers you can select varies as follows. You can display a waveform by setting the number even during waveform acquisition.

0, -1, -2, ...

0: The latest waveform; 1: The oldest waveform; 2: The second oldest waveform, ...

Displaying a List of High-Speed Waveforms (List)

When you stop waveform acquisition, you can list the captured waveform numbers and trigger times. You can select the waveform you want to view by selecting from the list.

Clearing History Waveforms (History)

▶ [See here.](#)



The search mode feature (Search Mode) is not available for displaying high-speed sampling waveforms of dual capture.

10 Cursor Measurement

You can move cursors on the waveforms displayed on the screen to view the measured values at the points where the cursors intersect the waveforms. You can select whether to measure the P-P compressed data values on the screen or the data values that have been acquired in the acquisition memory.

▶ [See here.](#)

Cursor Measurement ON/OFF (Mode)

Select whether to perform cursor measurements.

- OFF: Cursor measurement is not performed.
- ON: Cursor measurement is performed.

Cursor Type (Type)

There are five types of cursors.

- OFF: Cursor measurement is not performed.
- [Horizontal cursors \(Horizontal\)](#): Two horizontal cursors are used to measure vertical values.
- [Vertical cursors \(Vertical\)](#): Two vertical cursors are used to measure time values.
- [Marker cursors \(Marker\)](#): Four marker cursors that move on the waveform are used to measure waveform values.
- [Angle cursors \(Degree\)](#): Two angle cursors are used to measure angles.
- [Horizontal and vertical cursors \(H & V\)](#): Two horizontal cursors and two vertical cursors are used to measure vertical and time values.

Cursor Measurement on X-Y Waveforms

▶ [See here.](#)

Cursor Measurement on FFT Waveforms

▶ [See here.](#)

Horizontal Cursors (Horizontal)

Two dashed lines (horizontal cursors) appear on the horizontal axis. You can measure the vertical value at the position of each horizontal cursor and measure the level difference between the horizontal cursors.

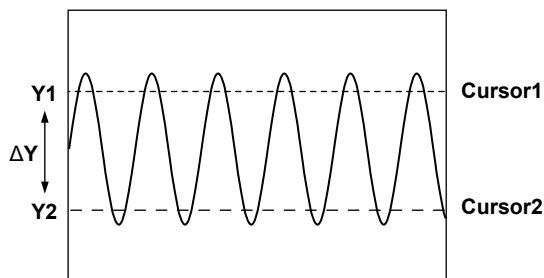

Measurement Source Waveform (Trace)

Set the measurement source waveform to one of the waveforms below.

CH1 to CH16,¹ 16chTEMP/VOLT,² CAN,³ LIN,³ SENT,³ RTmath1 to RTmath16, Math1 to Math8, Power,⁴ Harmonic⁴

- 1 You can select the channel of an installed module. On a 4-CH module, select sub channel 1 or 2. You cannot select the input channel of a logic module.
- 2 When a 16-CH Temperature/Voltage Input Module is installed. Select 16chTEMP/VOLT and then a sub channel.
- 3 On models with the /VCE option when a CAN bus monitor, CAN/CAN FD monitor, CAN & LIN bus monitor, or SENT monitor module is installed. After you select CAN, LIN, or SENT, select a sub channel. This cannot be selected on a CAN bus monitor, CAN/CAN FD monitor, or CAN & LIN bus monitor module if the data type (Value Type) is set to Logic. On a SENT monitor module, S&C and Error Trigger sub channels cannot be selected.
- 4 When power math (/G05 option) is on. Select Power or Harmonic and then a measurement function.

Cursor Movement (Cursor1/Cursor2)

Use Cursor1 and Cursor2 to move the cursors.

You can set in the range of -5 to +5 div from the center of the waveform display window. You can set them in 0.01 div steps.

Linking Cursors

If you select both Cursor1 and Cursor2 to be changed, you can move the cursors without changing the interval between Cursor1 and Cursor2.

Measurement Items (Item Setup)

You can measure the following vertical values at the cursor positions.

Y1	Vertical value at Cursor1
Y2	Vertical value at Cursor2
ΔY	Difference between the vertical values of Cursor1 and Cursor2

Other Setup (Other Setup)

- **Low-Speed Sampling and High-Speed Sampling Selection (Target)**

This is a setting used when dual capture is on. Set the measurement source to low-speed sampling (Slow) or high-speed sampling (Fast).

- **Cursor Brightness (Brightness)**

You can set the cursor brightness to any of the eight available levels.

Vertical Cursors (Vertical)

Two straight dashed lines appear on the vertical axis (these are the vertical cursors). You can measure the time between the trigger position and each cursor, the time difference between the two cursors, and the reciprocal of the time difference between the two cursors. You can also measure the vertical signal value at each cursor position and the level difference between the two cursors.

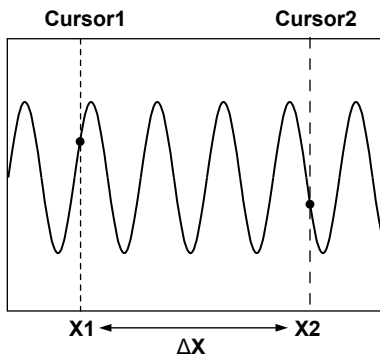

Measurement Source Waveform (Trace)

Set the measurement source waveform to one of the waveforms below.

CH1 to CH16,¹ 16chTEMP/VOLT,² CAN,³ LIN,³ SENT,³ RTmath1 to RTmath16, Math1 to Math8, All,⁴ Power,⁵ Harmonic⁵

- 1 You can select the channel of an installed module. On a 4-CH module, select sub channel 1 or 2.
- 2 When a 16-CH Temperature/Voltage Input Module is installed. Select 16chTEMP/VOLT and then a sub channel.
- 3 On models with the /VCE option when a CAN bus monitor, CAN/CAN FD monitor, CAN & LIN bus monitor, or SENT monitor module is installed. After you select CAN, LIN, or SENT, select a sub channel.
- 4 "All" specifies all channels. However, measured values that do not fit on the screen are not displayed.
- 5 When power math (/G05 option) is on. Select Power or Harmonic and then a measurement function. However, vertical cursor measurement is not possible on power math waveforms saved using SSD recording.

Cursor Movement (Cursor1/Cursor2)

Use Cursor1 and Cursor2 to move the cursors.

You can set the positions in the range of -5 to +5 div from the center of the waveform display window. The setting resolution varies depending on the display resolution.

- Scope mode: Set the positions in divisions.
- Recorder mode: When the time base is internal, set the positions in terms of the time (ddhhmmss) corresponding to divisions. When the time base is external, set the positions in terms of points (0 to record length).

Linking Cursors

If you select both Cursor1 and Cursor2 to be changed, you can move the cursors without changing the interval between Cursor1 and Cursor2.

Measurement Items (Item Setup)

You can measure the following horizontal values at the cursor positions.

X1	Time value at Cursor1
X2	Time value at Cursor2
ΔX	Difference between the time values of Cursor1 and Cursor2
$1/\Delta X$	Reciprocal of the difference between the time values of Cursor1 and Cursor2
Y1	Vertical value at the intersection of Cursor1 and the waveform ¹
Y2	Vertical value at the intersection of Cursor2 and the waveform ²
ΔY	Vertical value at the intersection of Cursor1/Cursor2 and the waveform ²

- 1 When Trace is set to All, the values for the channels of all installed modules, the sub channels, and the Math channel are measured.
- 2 This option does not appear when Trace is set to All.

Example of Logic Signal Measurement

When you measure logic waveforms using vertical cursors, the measured values of Y1 and Y2 are determined in the manner shown below.

When No Bits Are Turned Off

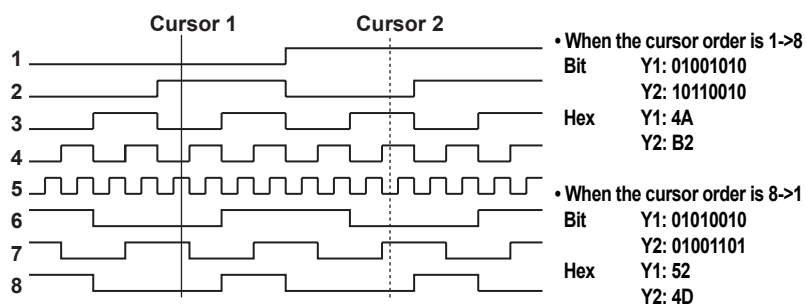

When Some Bits Are Turned Off

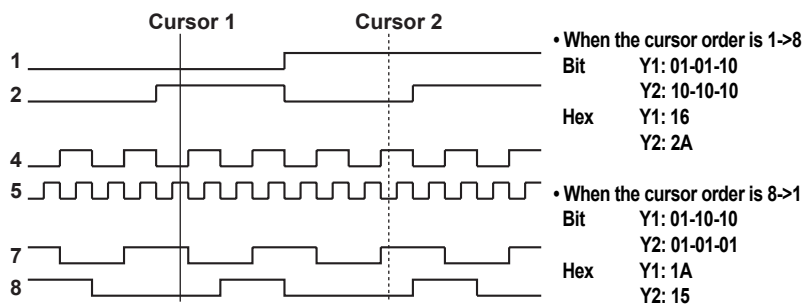

You can set the display format (Bit or Hex), the cursor order (Cursor Order), and the bit order (Bit Order) in the logic environmental settings.

▶ [See here.](#)

Other Setup (Other Setup)

- **Low-Speed Sampling and High-Speed Sampling Selection (Target)** ► [See here.](#)
- **Cursor Read Mode (Cursor Read Mode)**
Select the method for measuring cursor values from the following:
 - Display: The data values of P-P compressed values on the screen are measured.
 - ACQ: The values of data acquired in the acquisition memory are measured.
- **Cursor Brightness (Brightness)** ► [See here.](#)

Marker Cursors (Marker)

Four markers are displayed on the selected waveform. You can measure the level at each marker, the amount of time from the trigger position to each marker, and the level and time differences between markers.

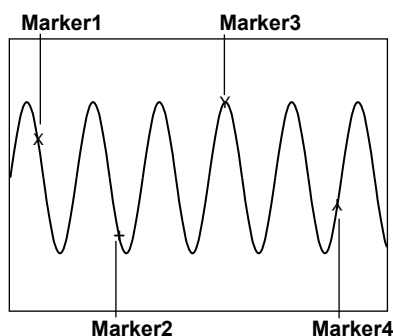

Marker Type (Marker)

Select the marker type (Type) from Marker1 to 4. The selected marker is displayed on the measurement source waveform.

Measurement Source Waveform (Trace)

Set the measurement source waveform for the selected marker to one of the waveforms below.

- OFF: Measurement is disabled.
- CH1 to CH16,¹ 16chTEMP/VOLT,² CAN,³ LIN,³ SENT,³ RTmath1 to RTmath16, Math1 to Math8, Power,⁴ Harmonic⁴
 - 1 You can select the channel of an installed module. On a 4-CH module, select sub channel 1 or 2. You cannot select the input channel of a logic module.
 - 2 When a 16-CH Temperature/Voltage Input Module is installed. Select 16chTEMP/VOLT and then a sub channel.
 - 3 On models with the /VCE option when a CAN bus monitor, CAN/CAN FD monitor, CAN & LIN bus monitor, or SENT monitor module is installed. After you select CAN, LIN, or SENT, select a sub channel. This cannot be selected on a CAN bus monitor, CAN/CAN FD monitor, or CAN & LIN bus monitor module if the data type (Value Type) is set to Logic. On a SENT monitor module, S&C and Error Trigger sub channels cannot be selected.
 - 4 When power math (/G05 option) is on. Select Power or Harmonic and then a measurement function. However, marker cursor measurement is not possible on power math waveforms saved using SSD recording.

Position (Position)

Set the position of the selected marker.

You can set the position in the range of -5 to +5 div from the center of the waveform display window. The setting resolution varies depending on the display resolution.

- Scope mode: Set the positions in divisions.
- Recorder mode: When the time base is internal, set the positions in terms of the time (ddhmmss) corresponding to divisions. When the time base is external, set the positions in terms of points (0 to record length).

Measurement Items (Item Setup)

Marker cursors move on the waveform data. You can measure the following values at the markers.

X1	Time value at Marker1
X2	Time value at Marker2
X3	Time value at Marker3
X4	Time value at Marker4
$\Delta(X2-X1)$	Difference between the time values of Marker1 and Marker2
$\Delta(X3-X1)$	Difference between the time values of Marker1 and Marker3
$\Delta(X4-X1)$	Difference between the time values of Marker1 and Marker4
$\Delta(X3-X2)$	Difference between the time values of Marker2 and Marker3
$\Delta(X4-X2)$	Difference between the time values of Marker2 and Marker4
$\Delta(X4-X3)$	Difference between the time values of Marker3 and Marker4
Y1	Vertical value at Marker1
Y2	Vertical value at Marker2
Y3	Vertical value at Marker3
Y4	Vertical value at Marker4
$\Delta(Y2-Y1)$	Difference between the vertical values of Marker1 and Marker2
$\Delta(Y3-Y1)$	Difference between the vertical values of Marker1 and Marker3
$\Delta(Y4-Y1)$	Difference between the vertical values of Marker1 and Marker4
$\Delta(Y3-Y2)$	Difference between the vertical values of Marker2 and Marker3
$\Delta(Y4-Y2)$	Difference between the vertical values of Marker2 and Marker4
$\Delta(Y4-Y3)$	Difference between the vertical values of Marker3 and Marker4

Other Setup (Other Setup)

- **Low-Speed Sampling and High-Speed Sampling Selection (Target)** ► [See here.](#)
- **Marker Shape (Marker Form)**
Set the shape of the displayed marker to one of the options below.
 - Mark (Mark): A mark
 - Line (Line): A crosshair
- **Cursor Read Mode (Cursor Read Mode)** ► [See here.](#)
- **Cursor Brightness (Brightness)** ► [See here.](#)

Angle Cursors (Degree)

You can measure time values and convert them to angles. On the time axis, set the zero point (Reference1 position), which will be the measurement reference, the end point (Reference2 position), and the reference angle that you want to assign to the difference between Reference1 and Reference2. Based on this reference angle, you can measure the angle between two angle cursors (Cursor1 and Cursor2).

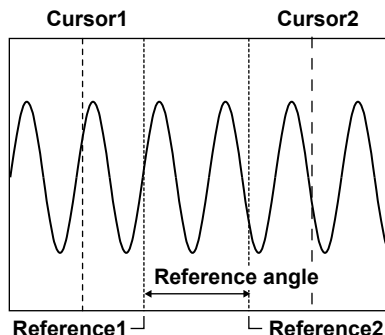

Measurement Source Waveform (Trace)

Set the measurement source waveform to one of the waveforms below.

CH1 to CH16,¹ 16chTEMP/VOLT,² CAN,³ LIN,³ SENT,³ RTmath1 to RTmath16, Math1 to Math8, All,⁴ Power,⁵ Harmonic⁵

- 1 You can select the channel of an installed module. On a 4-CH module, select sub channel 1 or 2.
- 2 When a 16-CH Temperature/Voltage Input Module is installed. Select 16chTEMP/VOLT and then a sub channel.
- 3 On models with the /VCE option when a CAN bus monitor, CAN/CAN FD monitor, CAN & LIN bus monitor, or SENT monitor module is installed. After you select CAN, LIN, or SENT, select a sub channel.
- 4 "All" specifies all channels.
- 5 When power math (/G05 option) is on. Select Power or Harmonic and then a measurement function. However, angle cursor measurement is not possible on power math waveforms saved using SSD recording.

Angle Cursor Movement (Cursor1/Cursor2)

Use Cursor1 and Cursor2 to move the cursors.

You can set the positions in the range of -5 to +5 div from the center of the waveform display window. The setting resolution varies depending on the display resolution.

- Scope mode: Set the positions in divisions.
- Recorder mode: When the time base is internal, set the positions in terms of the time (ddhmmss) corresponding to divisions. When the time base is external, set the positions in terms of points (0 to record length).

Linking Cursors

If you select both Cursor1 and Cursor2 to be changed, you can move the cursors without changing the interval between Cursor1 and Cursor2.

Reference Cursor Movement (Reference1/Reference2)

Set the zero point (Reference1) and the end point (Reference2).

You can set in the range of -5 to +5 div from the center of the waveform display window. The setting resolution varies depending on the display resolution.

- Scope mode: Set the positions in divisions.
- Recorder mode: When the time base is internal, set the positions in terms of the time (ddhmmss) corresponding to divisions. When the time base is external, set the positions in terms of points (0 to record length).

Linking Cursors

If you select both Reference1 and Reference2 to be changed, you can move the cursors without changing the interval between Reference1 and Reference2.

Measurement Items (Item Setup)

The instrument measures the angle cursor (Cursor1 and Cursor2) positions as angles.

X1	Angle of Cursor1 from Reference1
X2	Angle of Cursor2 from Reference1
ΔX	Angle difference between Cursor1 and Cursor2
Y1	Vertical value at the intersection of Cursor1 and the waveform ¹
Y2	Vertical value at the intersection of Cursor2 and the waveform ²
ΔY	Vertical value at the intersection of Cursor1/Cursor2 and the waveform ²

- 1 When Trace is set to All, the values for the channels of all installed modules, the sub channels, and the Math channel are measured.
- 2 This option does not appear when Trace is set to All.

Other Setup (Other Setup)

- **Low-Speed Sampling and High-Speed Sampling Selection (Target)** ► [See here.](#)
- **Reference Angle (Ref Value)**
Set the reference angle you want to assign to the range defined by Reference1 and Reference2.
Selectable range: 1 to 720
- **Cursor Read Mode (Cursor Read Mode)** ► [See here.](#)
- **Cursor Brightness (Brightness)** ► [See here.](#)

Horizontal and Vertical Cursors (H & V)

Displays the horizontal and vertical cursors simultaneously.

Measurement Source Waveform (Trace)

Set the measurement source waveform to one of the waveforms below.

CH1 to CH16,¹ 16chTEMP/VOLT,² CAN,³ LIN,³ SENT,³ RTmath1 to RTmath16, Math1 to Math8, Power,⁴ Harmonic⁴

- 1 You can select the channel of an installed module. On a 4-CH module, select sub channel 1 or 2. You cannot select the input channel of a logic module.
- 2 When a 16-CH Temperature/Voltage Input Module is installed. Select 16chTEMP/VOLT and then a sub channel.
- 3 On models with the /VCE option when a CAN bus monitor, CAN/CAN FD monitor, CAN & LIN bus monitor, or SENT monitor module is installed. After you select CAN, LIN, or SENT, select a sub channel. This cannot be selected on a CAN bus monitor, CAN/CAN FD monitor, or CAN & LIN bus monitor module if the data type (Value Type) is set to Logic. On a SENT monitor module, S&C and Error Trigger sub channels cannot be selected.
- 4 When power math (/G05 option) is on. Select Power or Harmonic and then a measurement function.

Cursor Movement (V Cursor1/V Cursor2, H Cursor1/H Cursor2)

Use the vertical cursors (V-Cursor1, V-Cursor2) and horizontal cursors (H-Cursor1, H-Cursor2) to move the cursors.

You can set positions in the range of -5 to +5 div from the center of the waveform display window. The setting resolution varies depending on the display resolution. The step resolution of the horizontal cursor is 0.01 divisions.

- Scope mode: Set the positions in divisions.
- Recorder mode: When the time base is internal, set the positions in terms of the time (ddhhmmss) corresponding to divisions. When the time base is external, set the positions in terms of points (0 to record length).

Linking Cursors

If you select V-Cursor1 and V-Cursor2 or select H-Cursor1 and H-Cursor2, you can move the cursors without changing the interval between V-Cursor1 and V-Cursor2 or between H-Cursor1 and H-Cursor2.

Measurement Items (Item Setup)

You can measure the following horizontal and vertical values at the cursor positions.

Horizontal Axis

X1	Time value at V-Cursor1
X2	Time value at V-Cursor2
ΔX	Difference between the time values of V-Cursor1 and V-Cursor2
$1/\Delta X$	Reciprocal of the difference between the time values of V-Cursor1 and V-Cursor2

Vertical Axis

Y1	Vertical value of H-Cursor1
Y2	Vertical value of H-Cursor2
ΔY	Difference between the vertical values of H-Cursor1 and H-Cursor2
$\Delta Y/\Delta X$	The amount of change in the vertical value per unit time in the cursor range

Other Setup (Other Setup)

- **Low-Speed Sampling and High-Speed Sampling Selection (Target)** ▶ [See here.](#)
- **Cursor Read Mode (Cursor Read Mode)** ▶ [See here.](#)
- **Cursor Brightness (Brightness)** ▶ [See here.](#)

Notes about Cursor Measurement

Cursor Measurement

- You cannot perform cursor measurement on snapshot waveforms or accumulated waveforms that have been acquired in the past. You can perform cursor measurement on the most recent accumulated waveform.
- For history waveforms, cursor measurement is performed on the waveform whose record number is selected.
- The measured time values are based on the time reference point.
 - Time reference point in Scope mode [▶ See here.](#)
 - Time reference point in Recorder mode [▶ See here.](#)
- The measured value for data that cannot be measured appears as "****."
- The pulse/rotate setting affects only the X-axis (horizontal) cursor measurement values.

Selectable Range of Cursor Positions

The number of acquired waveform data points is "display record length + 1." Therefore, for example, if the display record length is 10 kpoint, the number acquired data points is 10001. Since the number of points on the screen is 1001 points along the time axis, 10 measurement data points will exist at each point on the screen (one point at the right edge).

On the main window, if there is a single point of measured data at each display point, all measured data can be measured by moving the cursor at 0.01 division steps.

On the other hand, if there are several points of measured data at each display point, the cursor movement step is set to 0.005 divisions, and two points can be measured for each displayed point on the screen. In this situation, if the [cursor read mode](#) (Cursor Read Mode) is set to Display, the instrument measures the maximum and minimum values of measurement data at the displayed point. If the mode is set to ACQ, the instrument measures the data acquired in the acquisition memory, not the display data.

Further, if you use the zoom feature to expand the waveform so that the number of displayed points of measured data is 1 kpoint or less, cursor measurement will be possible on all measured data in the zoom area.

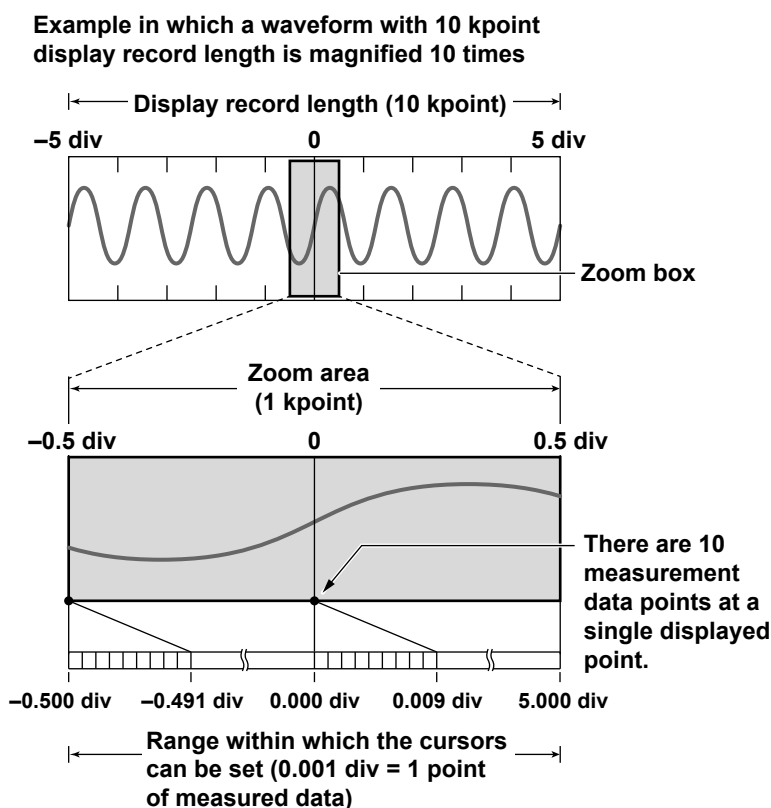

Notes about Using the 16-CH Temperature/Voltage Input Module (720221)

[▶ See here.](#)

11 Automated Measurement of Waveform Parameters

For waveforms that are displayed on the screen, various measurement items (waveform parameters), such as maximum and minimum values, can be measured automatically and their [statistics](#) can be calculated.

Turning Automated Measurement of Waveform Parameters On and Off (Mode)

With automated measurement of waveform parameters, this instrument automatically measures the specified measurement items on the source waveform.

- ON: Waveform parameters are automatically measured.
- OFF: Waveform parameters are not automatically measured.

Measurement Items (Measure Setup)

When dual capture is on, set the measurement items of high-speed sampling waveforms. To measure low-speed sampling waveforms, turn on low-speed sampling. ► [See here.](#)

Measurement Source Waveform (Trace)

Set the measurement source waveform to one of the waveforms below.

CH1 to CH16,¹ 16chTEMP/VOLT,² CAN,³ LIN,³ SENT,³ RTmath1 to RTmath16, Math1 to Math8, FFT1 to FFT8, XY1 to XY8, Power,⁴ Harmonic⁴

- 1 You can select the channel of an installed module. On a 4-CH module, select sub channel 1 or 2. Logic module channels are valid only for Frequency, Pulse, AvgFreq, Period, Duty, and Delay parameter measurements.
- 2 When a 16-CH Temperature/Voltage Input Module is installed. Select 16chTEMP/VOLT and then a sub channel.
- 3 On models with the /VCE option when a CAN bus monitor, CAN/CAN FD monitor, CAN & LIN bus monitor, or SENT monitor module is installed. After you select CAN, LIN, or SENT, select a sub channel. This cannot be selected on a CAN bus monitor, CAN/CAN FD monitor, or CAN & LIN bus monitor module if the data type (Value Type) is set to Logic. On a SENT monitor module, S&C and Error Trigger sub channels cannot be selected.
- 4 When power math (/G05 option) is on. Select Power or Harmonic and then a sub channel. However, automated measurement of waveform parameters is not possible on power math waveforms saved using SSD recording.

All Trace All Clear (All Trace All Clear)

You can turn off all items collectively for all set traces.

11 Automated Measurement of Waveform Parameters

Measurement Items (Item)

You can choose from the 28 measurement items and delay measurement items listed below. The instrument can store a total of up to 64000 data values for all waveforms (CH1 to CH16, 16chTEMP/VOLT, CAN, LIN, SENT, RTmath1 to RTmath16, Math1 to Math8, FFT1 to FFT8, Power,¹ Harmonic¹). A total of up to 80 measurement items can be displayed on the screen.²

- 1 The measurement items of power math waveforms (/G05 option) are P-P, Max, Min, Avg, Mid, and SDev.
- 2 Varies depending on the [Analysis Max Line](#) setting on the DISPLAY menu. The number of displayed items decreases while the setup menus displayed.

• Voltage Measurement Items

Peak to Peak (P-P)	P-P value (Max - Min) [V]
Amplitude (Amp)	Amplitude (High - Low) [V]
Maximum (Max)	Maximum voltage [V]
Minimum (Min)	Minimum voltage [V]
High	High voltage [V]
Low	Low voltage [V]
Average (Avg)	Average voltage $(1/n)\sum x_i$ [V]
Middle (Mid)	$(\text{Max} + \text{Min})/2$ [V]
RMS*	Rms voltage $((1/\sqrt{n})(\sum(xN^2))^{1/2})$ [V]
Std.Deviation (SDev)	Standard deviation $(1/n(\sum x_i^2 - (\sum x_i)^2/n))^{1/2}$ [V]
+Overshoot (+Over)	Overshoot $((\text{Max} - \text{High})/(\text{High} - \text{Low}) \times 100)$ [%]
-Overshoot (-Over)	Undershoot $((\text{Low} - \text{Min})/(\text{High} - \text{Low}) \times 100)$ [%]

The names in parentheses are the measurement item names that appear when the measured values are displayed.

* When the measurement source waveform is FFT (only when Type is PS or PSD), [overall values](#) are measured. However, the screen indicates "RMS."

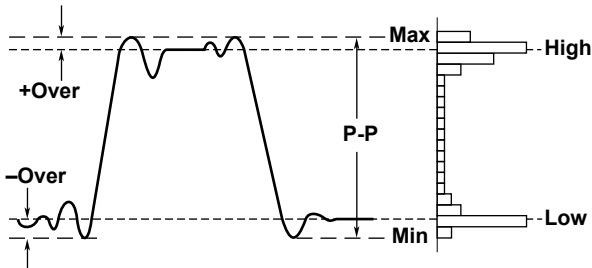

• Time Measurement Items

Rise	Rise time [s]
Fall	Fall time [s]
Frequency (Freq)	Frequency [Hz]
Period	Period [s]
+Width	Time width of the portion that is greater than the mesial value [s]
-Width	Time width of the portion that is less than the mesial value [s]
Duty cycle	Duty cycle $(+\text{Width}/\text{Period} \times 100)$ [%]
Avg.Frequency (Avg.F)	Average frequency in the measurement time period [Hz]
Avg.Period (Avg.P)	Average period in the measurement time period [s]

* The names in parentheses are the measurement item names that appear when the measured values are displayed.

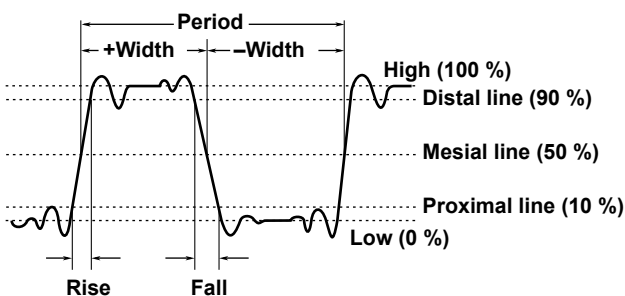

Pulse	Pulse count Set the measurement time period (Time Range) to a value appropriate for the pulse that you want to measure.
-------	--

When Pulse = 3

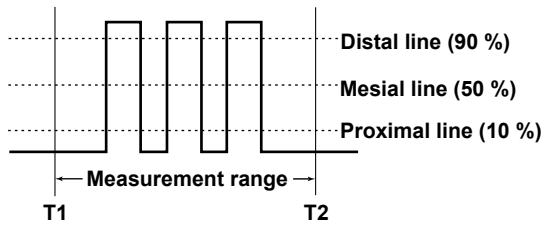

Burst1, Burst2	Burst period [s] Set the measurement time period (Time Range) to a value appropriate for the burst period that you want to measure.
----------------	--

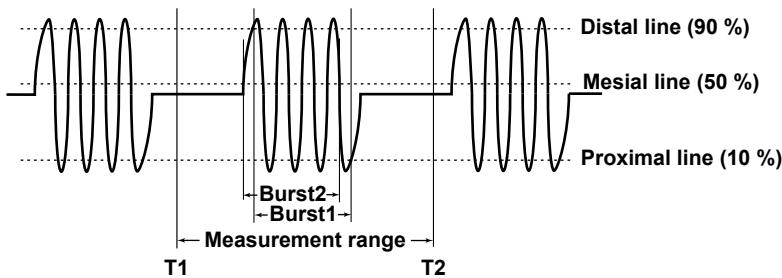

• **Other Measurement Items**

When Trace Is Set to CH, Sub Channel, RTMath, Math, or FFT

Integ1TY (Integ1)	Area under the positive parts
Integ2TY (Integ2)	Area of the positive amplitude – area of the negative amplitude

When Trace Is Set to XY

Integ1XY (Integ1)	Total triangular area of the X-Y waveform
Integ2XY (Integ2)	Total trapezoidal area of the X-Y waveform

* The names in parentheses are the measurement item names that appear when the measured values are displayed.

For detailed information about how the area is computed, see Appendix 1, “How to Calculate the Area of a Waveform.”

▶ [See here.](#)

• **Delay Setup (Delay Setup)**

Selecting the Delay check box allows you to set it. This does not appear when the measurement source waveform is XY.

▶ [See here.](#)

11 Automated Measurement of Waveform Parameters

- **All OFF (All OFF)**

You can turn off all the items for the waveform selected for Trace at once.

- **Copy (Copy to)**

You can copy the settings of the waveform selected for Trace to other traces.

- CH1 to CH16,¹ 16chTEMP/VOLT,² CAN,³ LIN,³ SENT,³ RTmath1 to RTmath16, Math1 to Math8, FFT1 to FFT8: Turn these on or off separately.
 - 1 You can select the channel of an installed module. On a 4-CH module, select sub channel 1 or 2. For logic modules, settings are copied between logic modules.
 - 2 When a 16-CH Temperature/Voltage Input Module is installed. Select 16chTEMP/VOLT and then a sub channel.
 - 3 On models with the /VCE option when a CAN bus monitor, CAN/CAN FD monitor, CAN & LIN bus monitor, or SENT monitor module is installed. After you select CAN, LIN, or SENT, select a sub channel. This cannot be selected on a CAN bus monitor, CAN/CAN FD monitor, or CAN & LIN bus monitor module if the data type (Value Type) is set to Logic. On a SENT monitor module, S&C and Error Trigger sub channels cannot be selected.
- All ON (All ON): All traces are turned on.
- All OFF (All OFF): All traces are turned off.
- Execute (Execute): Select Execute to copy the settings.



When Trace is set to XY, All OFF and Copy to are not available.

Delay Setup (Delay Setup)

The time difference between traces or the time difference from the trigger point to a rising or falling edge is called the delay between channels.

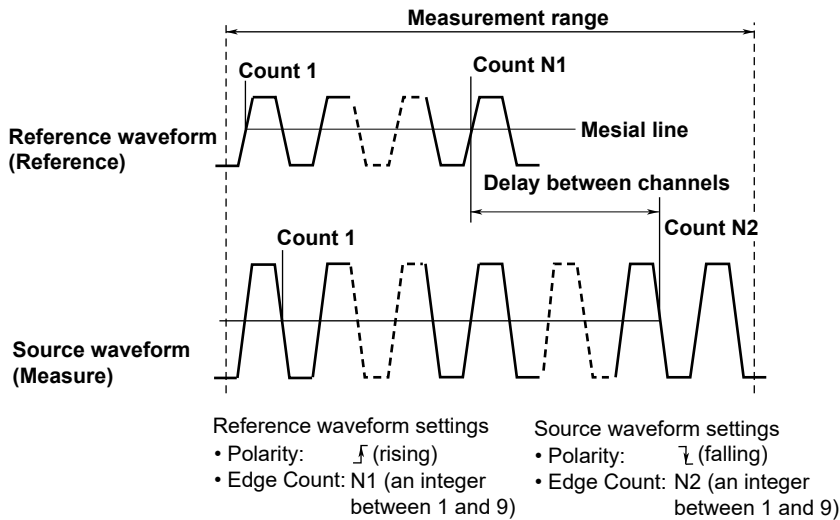

- **Measurement Source Waveform (Mode)**

The measurement source waveform is displayed. ► [See here.](#)

- **Display Mode (Mode)**

Select a delay measurement mode.

- Time: The delay between channels is displayed as a time.
- Angle (Degree): The delay between channels is displayed as an angle.

- **Polarity (Polarity)**
Select the slope of the edge you want to detect.
 - ⤴: Rising
 - ⤵: Falling
- **Edge Count (Edge Count)**
Sets which edge counted from the start point (T Range1) of the measurement time period to use as a detected point (measured point).
Selectable range: 1 to 9
- **Reference Waveform (Reference Trace)**
Select whether to use a trace or trigger as the reference for the reference waveform.
 - Trace (Trace): A trace is used.
 - Trigger (Trigger): A trigger is used.
- **Reference Waveform (Reference Trace)**
When Reference is set to Trace, set the reference waveform.
 - Trace (Trace): Select a reference waveform. CH1 to CH16,¹ 16chTEMP/VOLT,² CAN,³ LIN,³ SENT,³ RTmath1 to RTmath16, Math1 to Math8, FFT1 to FFT8
 - 1 You can select the channel of an installed module. On a 4-CH module, select sub channel 1 or 2.
 - 2 When a 16-CH Temperature/Voltage Input Module is installed. Select 16chTEMP/VOLT and then a sub channel.
 - 3 On models with the /VCE option when a CAN bus monitor, CAN/CAN FD monitor, CAN & LIN bus monitor, or SENT monitor module is installed. After you select CAN, LIN, or SENT, select a sub channel. This cannot be selected on a CAN bus monitor, CAN/CAN FD monitor, or CAN & LIN bus monitor module if the data type (Value Type) is set to Logic. On a SENT monitor module, S&C and Error Trigger sub channels cannot be selected.
 - Polarity (Polarity): Select the slope of the edge you want to detect (⤴: rising, ⤵: falling).
 - Edge Count (Edge Count): Sets which edge counted from the start point (T Range1) of the measurement time period to use as a detected point (reference point). Selectable range: 1 to 9



- The voltage level of the detected point is the mesial line.
- The measurement item name that appears when the measured values are displayed is (Delay).
- If Mode is set to Degree and Reference is set to Trigger, the measured value is displayed as '*****'.
- If you set the delay measurement's Reference to Trace, measurements will not be performed when the sample rates of the base waveform and the measurement source waveform are different. The measured value is displayed as '*****'.

Measurement Time Period (Time Range1/Time Range2)

Set the measurement time period using two vertical cursors. The position of the thin dashed line (Time Range1) is the measurement start point. The position of the thick dashed line (Time Range2) is the measurement end point. The default settings are -5 div +5 div. However, for SSD recording waveforms, the maximum number of data points is 100 Mpoint from Time Range 1.

Selectable range: -5 div to +5 div

- Scope mode: Set the positions in divisions. When dual capture is on, set the measurement range of high-speed sampling waveforms. To measure low-speed sampling waveforms, turn on low-speed sampling.
▶ [See here.](#)
- Recorder mode: When the time base is internal, set the positions in terms of the time (ddhhmmss) corresponding to divisions. When the time base is external, set the positions in terms of points (0 to record length).

The start and end points are similar to the settable range of the cursor display position in cursor measurement. For details, see "Selectable Range of Cursor Positions." ▶ [See here.](#)

Parameter Details (Detail)

Set the reference level that is used to measure various parameter values, such as the rise and fall times, for each measurement source waveform.

Setup Target Waveform (Trace)

Set the setup target waveform for the following settings.

- [Mode](#)
- [Distal, Mesial, Proximal](#)
- [High/Low](#)

• Setting the Distal, Mesial, and Proximal Units (Mode)

Set the method for setting the three levels that are used as references in the measurement of various parameter values, such as the rise and fall times.

- %
Assuming the High and Low values of a trace (CH1 to CH16,¹ 16chTEMP/VOLT,² CAN,³ LIN,³ SENT,³ RTmath1 to RTmath16, Math1 to Math8) to be 100 % and 0 %, respectively, set the distal, mesial, and proximal values to any percentage.
- Unit (Unit)
Set the distal, mesial, and proximal values of a trace (CH1 to CH16,¹ 16chTEMP/VOLT,² CAN,³ LIN,³ SENT,³ RTmath1 to RTmath16, Math1 to Math8) to physical values, such as voltages or temperatures.

- 1 You can select the channel of an installed module. On a 4-CH module, select sub channel 1 or 2. You cannot select the channel of a logic module.
- 2 When a 16-CH Temperature/Voltage Input Module is installed. Select 16chTEMP/VOLT and then a sub channel.
- 3 On models with the /VCE option when a CAN bus monitor, CAN/CAN FD monitor, CAN & LIN bus monitor, or SENT monitor module is installed. After you select CAN, LIN, or SENT, select a sub channel. This cannot be selected on a CAN bus monitor, CAN/CAN FD monitor, or CAN & LIN bus monitor module if the data type (Value Type) is set to Logic. On a SENT monitor module, S&C and Error Trigger sub channels cannot be selected.

• Distal, Mesial, Proximal Settings (Distal, Mesial, Proximal)

You can set the distal, mesial, and proximal values.

Selectable range: 0.0 to 100.0 % (in 0.1 % steps) or voltage or temperature values that correspond to ± 10 div (the steps that you can set voltage and temperature values in vary depending on the module. See ["Vertical Scale \(Voltage Scale\) Setting Range."](#)

• High/Low Specification Method (High/Low)

The high and low levels are the 100 % and 0 % levels used to measure various parameter values, such as the rise and fall times. You can choose one of the following methods for setting the high and low levels.

- Auto:
The instrument sets the high value to the high amplitude level and the low value to the low amplitude level based on the voltage level frequency of the waveform in the measurement time period while taking into account the effects of ringing, spikes, etc. This method is suitable for measuring square waves and pulse waves.
- Max-Min
The instrument sets the high and low values to the maximum and minimum values in the measurement time period. This method is suitable for measuring sinusoidal and saw waves. It is not suitable for waveforms that have ringing and spikes.

1-Cycle Mode (1-Cycle Mode)

Instead of automatically measuring the measurement time period specified by Time Range1 and Time Range2, you can automatically measure the first period after Time Range1.

The method of determining the period is the same as the method for determining the Period measurement item. In this mode, after the period is determined, the values of the measurement items related to voltage and area are computed. This mode is effective for measurement items, such as Rms or Avg, that may result in errors depending on the measurement time period setting.

The measurements of time axis items and X-Y areas are not affected.

- OFF: 1-cycle mode is disabled.
- ON: 1-cycle mode is enabled.

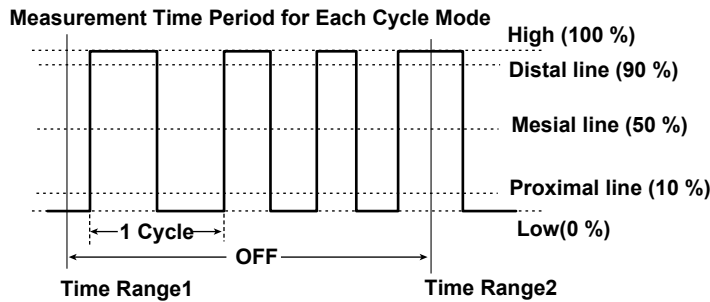

If the space between Time Range1 and Time Range2 is less than one period, "*****" is displayed for the measured value.

Measurement Location Indicator (Indicator)

Indicates the measured location of a specified item (selected from [measurement items](#), excluding Pulse) using cursors.

Setup Target Waveform (Trace)

Select the trace for which the cursor is displayed at the measurement location from the traces for which one or more measurement items are set.

Displayed Measurement Items (Item)

Select one of the measurement items for which the cursor is displayed from the measurement target items.

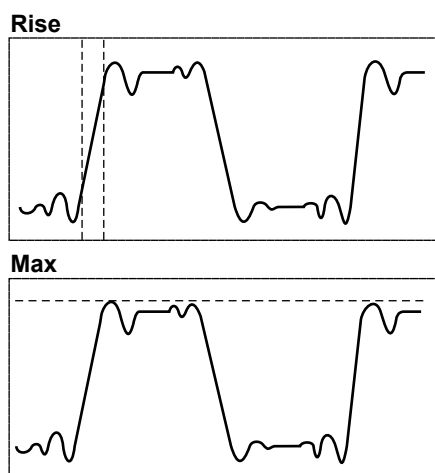

- Measurement locations of X-Y and FFT waveforms cannot be displayed.
- Measurement locations cannot be displayed when cursor measurement is on.
- If the statistical processing mode is set to Cycle or History, the measurement location cannot be displayed.

Extended Parameter Measurement (Area2 Mode)

In extended parameter measurement, in addition to the normal automated measurement of waveform parameters, automated measurement can be performed on another area (Area2). This is not available when dual capture is on.

Extended Parameter Measurement ON/OFF (Mode)

Select whether to perform extended parameter measurements.

- ON: Extended parameters are measured.
- OFF: Extended parameters are not measured.

Measurement Items (Measure Setup)

Set the measurement items of extended parameter measurement. The settings are the same as those for the normal automated measurement of waveform parameters.

▶ [See here.](#)

Measurement Time Period (Time Range1/Time Range2)

Set the measurement time period of extended parameter measurement.

▶ [See here.](#)

1 Cycle Mode (1-Cycle Mode)

Select whether to perform extended parameter measurements in 1-cycle mode.

▶ [See here.](#)

Low-Speed Sampling Waveform Measurement (Low Speed Measure)

This is a setting available in Scope mode when dual capture is on.

- **Low-Speed Sampling Waveform Measurement ON/OFF (Mode)**

Set whether to measure the waveform parameters of low-speed sampling waveforms.

- **Measurement Items (Measure Setup)**

Set the measurement items of low-speed sampling waveforms. The settings are the same as for the high-speed sampling waveforms. ▶ [See here.](#)

- **Measurement Time. (Time Range1/Time Range2)**

Set the measurement time period for low-speed sampling waveforms. The settings are the same as for the high-speed sampling waveforms. ▶ [See here.](#)

- **1-Cycle Mode (1-Cycle Mode)**

This is the same as for the high-speed sampling waveforms. ▶ [See here.](#)

Notes about Automated Measurement of Waveform Parameters

- Measurements cannot be made on a snapshot waveform or an accumulated waveform that is not the most recent waveform.
- When an item is cannot be measured, its measured value is displayed as '*****'. For example, it is displayed in the following cases.
 - When the measurement time period exceeds 100 Mpoint on a SSD recording waveform
 - When the delay measurement mode is Degree and the trigger source is set to the reference of the reference waveform
- The instrument may not measure correctly if the waveform amplitude is small.
- If there are two or more waveform periods within the measurement time period, the time-axis parameters are measured on the first period.
- When auto measurement is performed on waveforms measured by SSD recording, execution of automated measurement takes time because access to the internal SSD occurs.
- Automated measurement may require additional time depending on settings such as the memory length, the number of measurement items, and the input waveform. During automated measurement,  appears at the top of the screen.
- To cancel automated measurement, set Mode to OFF. Measurement stops immediately.
- For FFT waveforms, only the maximum and minimum values can be measured. However, when the spectrum type (Type) is power spectrum (PS or PSD), overall values (RMS is set to ON) can also be measured.
- When dual capture is on, automated measurement of waveform parameters is performed on high-speed sampling waveforms.
To perform automated measurement of waveform parameters on low-speed sampling waveforms, turn on the low-speed sampling measurement.
- The results of extended parameter measurement (Area 2) or automated measurement of the high-speed sampling waveforms of dual capture are displayed in italics.

Statistics (Statistics)

Statistics are calculated on the automated measurement values of waveform parameters. The following five statistics are computed for the measurement items whose measurement has been turned on. Statistics are displayed below each measurement item.

- Maximum: Maximum value
- Average: Average value
- Count: Number of measured values used to calculate statistics
- Minimum: Minimum value
- SDev: Standard deviation



When statistical processing is performed, the maximum number of measurement results that can be displayed on the screen is 12.* If 13 or more measurement items are selected when there is a single measurement source waveform, the first 12 items in the setup dialog box will be displayed (PP, Amp, Max, Min, . . . , Init1XY, Init2XY). When there are multiple measurement source waveforms, the measurement results of all channels are displayed first for each measurement item.

* Varies depending on the [Analysis Max Line](#) setting on the DISPLAY menu. The number of displayed items decreases while the setup menus displayed.

Example 1:

When 13 items (P-P, Amp, Max, Min, . . . , SDev, +Over, -Over, Rise) are selected from CH1 only
1 items (P-P, Amp, Max, Min, . . . , SDev, +Over, -Over) are displayed from CH1.

Example 2:

When seven items (P-P, Amp, Max, Min, High, Low, Avg) are selected from CH1 and CH2
The following 12 items are displayed: CH1: P-P, CH2: P-P, CH1: Amp, CH2: Amp, . . . , CH1: Low, CH2: Low 12.

You can view the statistics of other items in the following way.

- Load the items into a PC using the communication feature.
- Save the statistical items as automated measurement values of waveform parameters, and load the data into a PC.
- View a list of the statistical processing results for cyclic statistical processing and history statistical processing.

Statistics ON/OFF (Mode)

Set whether to perform statistical processing on the automated measurement values of waveform parameters.

- ON: Statistical processing is performed.
- OFF: Statistical processing is not performed.

Statistical Processing Type (Type)

Select the statistical processing type from the following.

- **Continuous statistical processing (Continuous):** Statistical processing is performed while acquiring waveforms.
- **Cyclic statistical processing (Cycle):** Statistical processing is performed for each period (cyclic statistical processing).
- **Statistical processing of history waveforms (History):** Statistical processing is performed on history waveforms.

Continuous Statistical Processing (Continuous)

While acquiring waveforms, the instrument calculates the statistics of the waveforms that it has acquired so far. If you stop waveform acquisition and then restart it, the instrument will continue statistical processing and include the data from before waveform acquisition was stopped. The instrument also performs statistical processing for selected automatically measured items that are not displayed. The number of measured values used to calculate statistics (Count) is equal to the number of waveforms that have been acquired up to that point.

If you add an additional automatically measured item to apply statistical processing to, the number of measured values used to calculate the statistics (Cnt) is reset to 1 regardless of whether the instrument is acquiring waveforms.

Cyclic Statistical Processing (Cycle)

The software determines the cycles in the displayed waveform starting with the oldest data, measures the selected automated measurement parameters over the data within the cycles, and performs statistical processing. The method used to determine the period in cyclic statistical processing is the same as the method used to determine the Period waveform parameter. You can choose whether to determine the period for the selected waveform and use it on all source waveforms or to determine individual periods for each waveform.

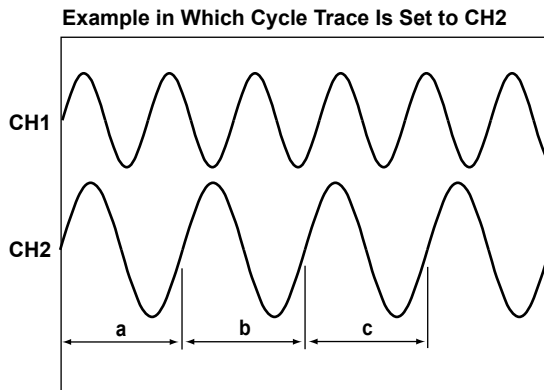

Measures the items in ranges a, b, and c, and calculates statistics on the items in the order a, b, and c.

The items of other channels are also measured in ranges a, b, and c. If you select Own, the items are measured automatically over each waveform's period.



The following items are not measured:

- For waveforms that are used to determine the period
Avg.Frequency, Avg.Period, Pulse (pulse count), Integ1XY (area), Integ2XY (area), Delay
- For other waveforms
Integ1XY (area), Integ2XY (area), Delay

Cycle Trace (Trace)

Selects the source waveform used to determine the period.

- **CH1 to CH16,¹ 16chTEMP/VOLT,² CAN,³ LIN,³ SENT,³ RTmath1 to RTmath16, Math1 to Math8**

The period of the specified waveform is applied to all waveforms.

- 1 You can select the channel of an installed module. On a 4-CH module, select sub channel 1 or 2.
- 2 When a 16-CH Temperature/Voltage Input Module is installed. Select 16chTEMP/VOLT and then a sub channel.
- 3 On models with the /VCE option when a CAN bus monitor, CAN/CAN FD monitor, CAN & LIN bus monitor, or SENT monitor module is installed. After you select CAN, LIN, or SENT, select a sub channel. This cannot be selected on a CAN bus monitor, CAN/CAN FD monitor, or CAN & LIN bus monitor module if the data type (Value Type) is set to Logic. On a SENT monitor module, S&C and Error Trigger sub channels cannot be selected.

- **Own**

A period is determined for each source waveform. However, if signals that have different periods are applied to multiple channels, the number of iterations of automated measurement and statistical processing for each signal is equal to the number of periods in the slowest signal.

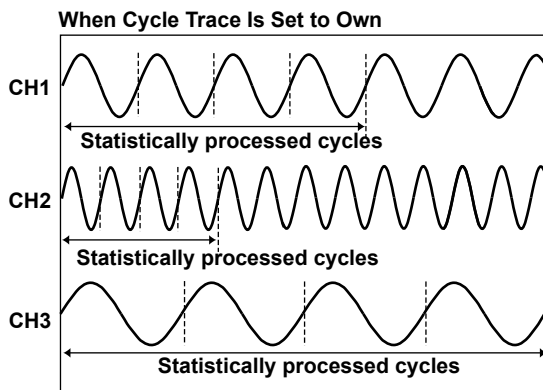

The number of cycles in the channel with the slowest cycle (CH3) is four, so statistical processing is performed on the four oldest cycles of the data for CH1 and CH2. The remaining data is not used for statistical processing.



Statistical processing is performed in periods that are determined in order from the oldest data of the displayed waveform. It cannot be used at the same time as 1-cycle mode.

Measurement Execution (Execute)

Executes statistical processing. You can select Execute Measure when Mode is set to Cycle Statistics or History Statistics.

Press Abort to stop statistical processing.



- The number of cycles being used for the cyclic statistical processing is displayed in the statistical display's Count column.
- The number of cycles that can be used in cyclic statistical processing varies depending on the number of measured items that the instrument is calculating the statistics of.
64000/(the number of measured items that the instrument is calculating the statistics of)

Result Display (Result List)

Displays a list of calculated statistics. You can display the list of statistics when Mode is set to Cycle Statistics or History Statistics.

Numbers are assigned to the data in order from the oldest cycle data or history data, and the automated measurement results for each number are displayed.

The maximum and minimum values for each parameter are indicated on the list by ↑ (maximum value) and ↓ (minimum value). If the same value appears in multiple locations, the oldest occurrence of the value is marked as the maximum or minimum value.

The number of data points that can be listed is 64000. If the number of data points exceeds 64000, the most recent data points in the history waveform or automatically measured item data are displayed. If the number of data points exceeds 64000, the maximum and minimum values may be outside of range of the displayed list. When this happens, ↑ (maximum value) and ↓ (minimum value) will not appear.

- **Sort (Sort)**

Sorts the list in the specified order.

Forward (from the oldest) or Reverse (from the latest)

- **Statistics Max (Statistics Max)**

Moves to the maximum value ↑ of the selected measurement item.

- **Statistics Min (Statistics Min)**

Moves to the minimum value ↓ of the selected measurement item.



In cyclic statistical processing, you can zoom in on the waveform (for one cycle) of the selected number by tapping the cycle data in the result list display. You can also select cycle data using the jog dial and the SET key.

Statistical Processing of History Waveforms (History)

In the statistical processing of history waveforms, the instrument measures automatically measured items on the acquired waveform using the history feature and performs statistical processing on them. The instrument calculates statistics from the oldest waveform. The waveforms that statistical processing is performed on are those waveforms shown in the List that can be accessed from the HISTORY menu. Statistical processing of history waveforms can be used with 1-cycle mode and the delay feature.

Measurement Execution (Execute)

This item is the same as the Execute Measure item for cyclic statistical processing.

▶ [See here.](#)



- In the statistical processing of history waveforms, the number of history waveforms that processing is performed on is indicated in the Count column of the statistical value display.
 - The number of history waveforms that can be used in the statistical processing of history waveforms varies depending on the number of measured items that the instrument is calculating the statistics of.
64000/(the number of measured items that the instrument is calculating the statistics of)
-

Result Display (Result List)

This item is the same as the Display Result item for cyclic statistical processing.

▶ [See here.](#)



In the statistical processing of history waveforms, you can display a history waveform by tapping the history data in the result list display. You can also select history data using the jog dial and the SET key.

Notes about Statistical Processing

- During statistical processing,  appears in the center of the screen. All soft keys except Abort are invalid.
- Statistical processing cannot be performed:
 - On SSD recorded waveforms.
 - On FFT waveforms.
 - On Math waveforms.
- The starting and stopping of statistical processing may require additional time depending on settings such as the record length, the number of statistical processing items, and the input waveform.
- When dual capture is on, statistical processing is performed on automatically measured values of high-speed sampling waveforms.

However, when the statistical processing type is cyclic statistical processing and auto measurement on low-speed sampling waveforms (low-speed sampling measurement) is in progress, cyclic statistical processing is performed also on the automatically measured values of low-speed sampling waveforms.
- In Recorder mode, only cyclic statistical processing can be performed.

Notes about Using the 16-CH Temperature/Voltage Input Module (720221)

- ▶ [See here.](#)

12 FFT

The power spectrum of the input waveform can be displayed in the FFT window. There are two FFT windows, and up to eight FFT waveforms can be displayed (up to four in each FFT window). On models with the user-defined math function (/G02 option), the following spectra can be analyzed in addition to the power spectrum. FFT analysis cannot be performed on waveforms stored through SSD recording.

Linear spectrum, power spectrum density, cross spectrum, transfer function, coherence function

The following settings are available.

- [FFT Window ON/OFF \(Window1, Window2\)](#)
- [All Math Setup \(FFT Setup\)](#)
- [Math Range Setup \(Range Setup\)](#)
- [FFT Trace Setup \(Trace Setup\)](#)
- [FFT Waveform Cursor Measurement \(Cursor\)](#)
- [Display Ratio of the Main Window \(Main Ratio\)](#)
- [Window Layout \(Window Layout\)](#)
- [Combine Display \(Combine Display\)](#)
- [Window Display Setup \(Window Display Setup\)](#)
- [Average Setup \(Average Setup\)/G02 option\)](#)

FFT Window ON/OFF (Window1, Window2)

Select whether to display each FFT window (Window1, Window2).

- ON: The FFT window is displayed.
- OFF: The FFT window is not displayed.

All Math Setup (FFT Setup)

You can specify the Window1 and Window2 settings collectively using the setup dialog box.

Window1, Window2

Using the check boxes, select whether to display each FFT window (Window1, Window2). Select the check box to display the window.

Start Point (Start Point)

Set the computation start point. The default setting is -5 divisions.

Selectable range: -5 div to +5 div

- Scope mode: Set the positions in divisions.
- Recorder mode: When the time base is internal, set the positions in terms of the time (ddhhmmss) corresponding to divisions. When the time base is external, set the positions in terms of points (0 to record length).

The start and end points are similar to the settable range of the cursor display position in cursor measurement. For details, see "Selectable Range of Cursor Positions."

▶ [See here.](#)

Number of FFT Points (Points)

You can set the number of points from the start of computation on the T-Y waveform to one of the options below.

1 k, 2 k, 5 k, 10 k, 20 k, 50 k,* 100 k*

- * When 50 k is selected, only FFT1, FFT2, FFT5, and FFT6 can be computed. When 100 k is selected, only FFT1 and FFT5 can be computed.

Window Function (Window)

You can select the window function from the following options.

Rect (Rectangular window)

The rectangular window is suited to transient signals, such as impulse waves, which attenuate completely within the time window.

Hanning (Hanning window)

The Hanning window encourages continuity of the signal by gradually attenuating the parts of the signal located near the ends of the time window down to the 0 level. Hence, it is suited to continuous signals. The Hanning window has a higher frequency resolution than the flattop window.

FlatTop (Flattop window)

The Hanning window encourages continuity of the signal by gradually attenuating the parts of the signal located near the ends of the time window down to the 0 level. Hence, it is suited to continuous signals. The flattop window has a higher spectral level accuracy than the flattop window.

Hamming (Hamming window)

In the Hanning window, the values at the ends become 0 and the signal components there do not affect the spectrum. The Hamming window is a corrected Hanning window. Its characteristics are similar to those of the Hanning window, but the frequency resolution of its main beam is greater than that of the Hanning window. The Hamming window is suited for separating close signals.

Exponential (Exponential Window)

This window removes noise components from the input signal. It can only be selected for the user-defined math function (/G02 option). It is effective for frequency response test signals using impulse excitation. You can set the [damping rate](#), [Force1](#), and [Force2](#).

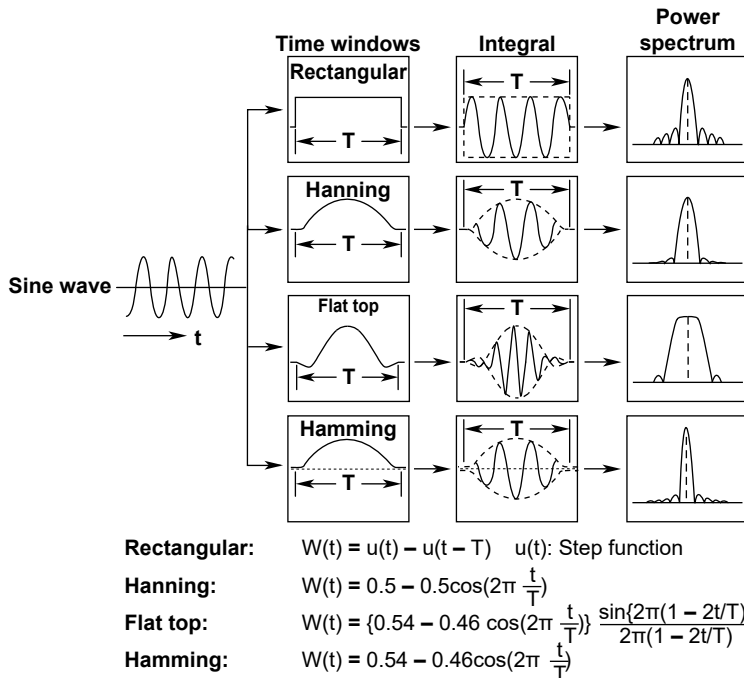

For details on exponential windows, see appendix 2.

Exponential Window Setup (Setup)

Set the following items when the window function is Exponential.

- **Damping Rate (Damping Rate)**

The damping rate is the weight of the last data point, with the weight of the first data point in the specified number of FFT points taken to be 100 % (= 1). It is set as a percentage between 1 to 100 % (in 1 % steps). When the damping rate is set to 100 %, the operation is the same as for a rectangular window. The setting is shared between input signals and output (response) signals.

- **Force1**

Set the percentage of FFT points to use to perform computation from the beginning of the data. Set it between 1 and 100 % (in 1 % steps). If it is set to 100 %, the operation is the same as for a rectangular window. For the points outside the range, an average of the results computed with the exponential window is used. This applies to the input signal (the first parameter) of a single waveform FFT or two-waveform FFT.

- **Force2**

This setting applies to the output (response) signal (second parameter) of a two-waveform FFT. The settings are the same as those of the Force1.

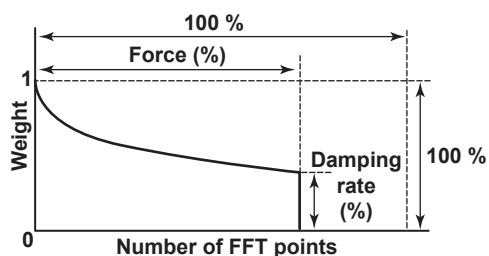

FFT Trace Setup

You can set the following items while viewing a list of the FFT (FFT1 to FFT8) settings. FFT1 to FFT2 are displayed in Window1, and FFT5 to FFT8 are displayed in Window2. The settings are the same as the trace settings. ► [See here.](#)

- Mode (Mode)
- Type (Type)
- Sub Type (Sub Type)
- Source 1 and Source 2 (Source1/Source2)

Math Range Setup (Range Setup)

Set the start point and number of FFT points for each FFT window. These settings are the same as those for all math setup (FFT Setup).

► [See here.](#)

FFT Trace Setup (Trace Setup)

FFT Trace Selection (Trace)

Select the FFT waveform you want to configure from FFT1 to FFT8.

FFT ON/OFF (Mode)

Set whether to perform FFT analysis on the selected trace.

- ON: FFT analysis is performed.
- OFF: FFT analysis is not performed.

FFT Math Setup (FFT Math Setup)

- [Type \(Type\)](#): This is fix to PS when the /G02 option is not installed.
- [Sub Type \(Sub Type\)](#): This is fix to LOGMAG when the /G02 option is not installed.
- [Analysis Source Waveform \(Source1/Source2\)](#)

Vertical Scale (Vert Scale)

Select the method for setting the vertical scale from the following options.

- Auto (Auto): The center and scale of the vertical axis are set automatically.
- Manual (Manual): The center and scale of the vertical axis must be set manually.

Center (Center)

When the vertical scale is set to Manual, set the center.

Selectable range: $-9.9999E+30$ to $+9.9999E+30$, in $1E-30$ steps

Sensitivity (Sensitive)

When the vertical scale is set to Manual, set the center and scale of the vertical axis.

Selectable range: 0 to $+9.9999E+30$, in $1E-30$ steps

Unit (Unit)

- ▶ [See here.](#)

FFT Math Setup (FFT Math Setup)

On models with the user-defined math function (/G02 option), the following spectra can be analyzed.

Linear spectrum, power spectrum density, cross spectrum, transfer function, coherence function

Spectrum Type (Type/Sub Type)

Set the spectrum type.

Type	Sub Type	Description
LS	MAG	Magnitude of the linear spectrum of the specified waveform
LS	LOGMAG	Logarithmic magnitude of the linear spectrum of the specified waveform
LS	PHASE	Phase of the linear spectrum of the specified waveform
LS	REAL	Real part of the linear spectrum of the specified waveform
LS	IMAG	Imaginary part of the linear spectrum of the specified waveform
RS	MAG	Magnitude of the specified waveform's RMS spectrum
RS	LOGMAG	Logarithmic magnitude of the specified waveform's RMS spectrum
PS	MAG	Magnitude of the power spectrum of the specified waveform
PS	LOGMAG	Logarithmic magnitude of the power spectrum of the specified waveform
PSD	MAG	Magnitude of the power spectrum density of the specified waveform
PSD	LOGMAG	Logarithmic magnitude of the power spectrum density of the specified waveform
CS	MAG	Magnitude of the cross spectrum of the two specified waveforms
CS	LOGMAG	Logarithmic magnitude of the cross spectrum of the two specified waveforms
CS	PHASE	Phase of the cross spectrum of the two specified waveforms
CS	REAL	Real part of the cross spectrum of the two specified waveforms
CS	IMAG	Imaginary part of the cross spectrum of the two specified waveforms
TF	MAG	Magnitude of the transfer function of the two specified waveforms
TF	LOGMAG	Logarithmic magnitude of the transfer function of the two specified waveforms
TF	PHASE	Phase of the transfer function of the two specified waveforms
TF	REAL	Real part of the transfer function of the two specified waveforms
TF	IMAG	Imaginary part of the transfer function of the two specified waveforms
CH	MAG	Magnitude of the coherence function of the two specified waveforms

Analysis Source Waveform (Source1/Source2¹)

Set the analysis source waveform to one of the waveforms below.

CH1 to CH16,² 16chTEMP/VOLT,³ CAN,⁴ LIN,⁴ SENT,⁴ RTmath1 to RTmath16, Math1 to Math8

- 1 Set Source2 when the type is CS, TF, or CH.
- 2 You can select the channel of an installed module. On a 4-CH module, select sub channel 1 or 2. You cannot select the channel of a logic module.
- 3 When a 16-CH Temperature/Voltage Input Module is installed. Select 16chTEMP/VOLT and then a sub channel.
- 4 On models with the /VCE option when a CAN bus monitor, CAN/CAN FD monitor, CAN & LIN bus monitor, or SENT monitor module is installed. After you select CAN, LIN, or SENT, select a sub channel. This cannot be selected on a CAN bus monitor, CAN/CAN FD monitor, or CAN & LIN bus monitor module if the data type (Value Type) is set to Logic. On a SENT monitor module, S&C and Error Trigger sub channels cannot be selected.



When analysis is performed on a linearly scaled channel, the scaled values are used.

FFT Waveform Cursor Measurement (Cursor)

Cursor Measurement ON/OFF (Mode)

Select whether to perform cursor measurements.

- OFF: Cursor measurement is not performed.
- ON: Cursor measurement is performed.

Cursor Type (Type)

The following types of FFT waveform cursors are available.

- **Marker cursors (Marker):** You can use four marker cursors to measure frequencies, levels, and the distances between markers.
- **Peak cursors (Peak):** You can use peak cursors to measure peak frequency and level values.

Marker Cursors (Marker)

You can measure the frequency and level at each marker and the frequency and level differences between markers. You can select a measurement source waveform for each cursor.

Marker Type (Target Marker)

Select the marker type (Type) from Marker1 to 4. The selected marker is displayed on the measurement source waveform.

Measurement Source Waveform (Trace)

Set the measurement source waveform for the selected marker to one of the waveforms below.

- OFF: Disables measurement.
- FFT1 to FFT8: Select the measurement source FFT waveform.

Position (Position)

Set the position of the selected marker.

You can move the markers within the range of -5 to 5 divisions of the frequency axis in 0.01 division steps.

Marker Shape (Marker Form)

Set the shape of the displayed marker to one of the options below.

- Mark (Mark): A mark
- Line (Line): A crosshair

Measurement Items (Item Setup)

Marker cursors move on the waveform data. You can measure the following values at the markers.

X1	Frequency at Marker1
X2	Frequency at Marker2
X3	Frequency at Marker3
X4	Frequency at Marker4
$\Delta(X2-X1)$	Frequency difference between Marker1 and Marker2
$\Delta(X3-X1)$	Frequency difference between Marker1 and Marker3
$\Delta(X4-X1)$	Frequency difference between Marker1 and Marker4
$\Delta(X3-X2)$	Frequency difference between Marker2 and Marker3
$\Delta(X4-X2)$	Frequency difference between Marker2 and Marker4
$\Delta(X4-X3)$	Frequency difference between Marker3 and Marker4
Y1	Level at Marker1
Y2	Level at Marker2
Y3	Level at Marker3
Y4	Level at Marker4
$\Delta(Y2-Y1)$	Level difference between Marker1 and Marker2
$\Delta(Y3-Y1)$	Level difference between Marker1 and Marker3
$\Delta(Y4-Y1)$	Level difference between Marker1 and Marker4
$\Delta(Y3-Y2)$	Level difference between Marker2 and Marker3
$\Delta(Y4-Y2)$	Level difference between Marker2 and Marker4
$\Delta(Y4-Y3)$	Level difference between Marker3 and Marker4

Peak Cursors (Peak)

Detects the peak of each FFT waveform (FFT1 to FFT8) and measures its frequency and level. You can set the peak detection range for each FFT window.

Management Range (FFT1 Range1/Range2, FFT2 Range1/Range2)

- FFT1 Range1/Range2: Set the range to detect peaks in Window1.
- FFT2 Range1/Range2: Set the range to detect peaks in Window2.

Selectable range: -5 to +5 div

Measurement Items (Item Setup)

The following values at the peaks are measured.

- F1 to F8: The frequency at the peak position of each FFT waveform (FFT1 to FFT8)
- Y1 to Y8: The level at the peak position of each FFT waveform (FFT1 to FFT8)

Display Ratio of the Main Window (Main Ratio)

▶ [See here.](#)

Window Layout (Window Layout)

Set the window layout when two FFT windows are displayed or when a combination of two windows—an FFT window and another window (zoom window, X-Y window, or harmonic window)—are displayed.

This is synchronized with the setup menu (Window Layout) of the zoom window, X-Y window, and harmonic window.

- Side: Horizontal
- Vertical: Vertical (valid only when Main Ratio is set to 0 % when multiple X-Y windows are displayed)

Combine Display (Combine Display)

The two FFT Windows (Window1 and Window2) can be consolidated in a single window.

If the FFT window and the zoom window or FFT window are displayed at the same time, only one FFT window can be displayed. You can display all FFT windows by combining the windows.

- ON: The windows are consolidated.
- OFF: The windows are not consolidated.

Window Display Setup (Window Display Setup)

Window Selection (Window Select)

Select the window (Window1 or Window2) that you want to configure the display of.

Horizontal Scale (Horiz. Axis)

Select how to set the horizontal scale of FFT window 1 and FFT window 2 from the following.

- Hz: A normal (linear) scale is used.
- Log Hz: A logarithmic scale is used.

Horizontal Scale Display Range (Horiz. Scale)

Select the display range of the horizontal scale of FFT window 1 and FFT window 2 from the following.

- Auto: The horizontal center point and span are set automatically (the entire range is displayed).
- Left/Right: You must set the left and right ends of the display range manually.
- Center/Span: You must set the horizontal center point and span manually. You can select this only when the horizontal scale is set to Hz.

Horizontal Range (Left/Right, Center/Span)

- **Horizontal Range (Left/Right)**

When the horizontal scale is set to Left/Right, set the left and right ends of the horizontal display range.
Selectable range: 0.00 kHz to the maximum frequency

- **Horizontal Range (Center/Span)**

When the horizontal scale is set to Center/Span, set the center point and span of the horizontal display range.
Selectable range of the center: 0.00 kHz to the maximum frequency
Selectable range of the span: the frequency resolution x10 to the maximum frequency

Display format (Format)

Select the number of divisions on FFT window 1 and FFT window 2 from the following.

Average Setup (Average Setup)/(G02 option)

This is a setting available in Scope mode.

You can average and compute the peak values of FFT waveforms. You can configure these settings for each FFT window (Window1 and Window2).

Average Modes (Average Mode)

The following types of averaging are available.

- OFF: Averaging is not performed.
- [Linear averaging \(Linear\)](#): Values are averaged linearly.
- [Exponential averaging \(Exp\)](#): Values are averaged exponentially.
- [Peak computation \(Peak\)](#): Peak values are computed.

Linear Averaging (Linear)

The number of values specified by the average count are added and divided by the average count, and the resulting values are used to display the waveform. For the equation, see the equation for linear averaging in [Averaging Mode](#).

- **Average Domain (Average Domain)**

Select what to average.

- Time: A time-domain waveform is averaged.
- Freq: A frequency-domain waveform is averaged.

- **Linear Count (Linear Count)**

Set the average count.

Selectable range: 2 to 128 in 2ⁿ steps

Exponential Averaging (Exp)

Using the specified attenuation constant, the instrument attenuates the influence of previous computed data to produce averaged values, and uses the results to display the waveform. For the equation, see the equation for exponential averaging in [Averaging Mode](#).

- **Average Domain (Average Domain)**

▶ [See here](#).

- **Attenuation Constant (Average Weight)**

Set the attenuation constant.

Selectable range: 2 to 256 in 2ⁿ steps

Peak Computation (Peak)

The maximum value at each point of the computed data is determined, and the resulting values are used to display the waveform. For each computation, the new computed value is compared with the past value, and the larger value is kept.

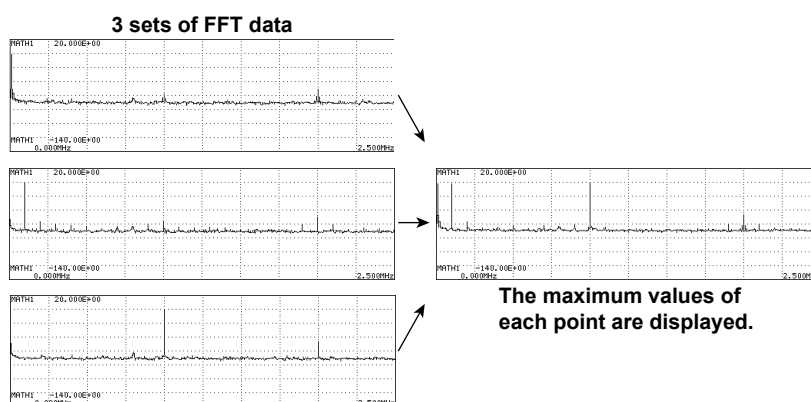

- The instrument normally performs scaling by using the computed data at the beginning (auto scaling). For coherence functions and in other cases where the amplitude of the averaged waveform changes significantly, use manual scaling.
- When you execute averaging, after measurement is stopped, computation cannot be restarted.
- If you measure an averaged waveform with auto scaling enabled, you cannot change the scaling by switching to manual scaling after measurement has stopped. Changes to the scaling settings are applied to the next measurement.
- User-defined averaging cannot be performed on pulse width computation.
- If you change the computation conditions during averaging, the computed data up to that point is deleted, and averaging starts over.

Notes about FFT Computation

Notes about Displaying Power Spectra

- You cannot display a power spectrum if the display record length is less than the number of computed data points (Point).
- The following settings are shared for all computation channel: FFT Points, Window, and Start Point.

Notes on Computation

- Computation is normally performed on the sampled data in the acquisition memory. For waveforms that are acquired in Envelope mode, computation is performed on the maximum and minimum values at each acquisition interval.
- The slower the source waveform sample rate, the lower the maximum frequency of FFT waveforms. When the horizontal scale display range is Auto, the horizontal scale display range is determined according to the maximum sample rate for acquiring waveforms, so waveforms acquired in channels with slow sample rates and FFT waveforms acquired with the sample period set slow with the sample rate or sample interval in the channel settings is displayed as if the high frequency side was cut off in the middle.
- An icon  appears at the top of the screen when FFT computation is being executed.
- FFT analysis cannot be performed on waveforms stored through SSD recording.

Notes about Using the 16-CH Temperature/Voltage Input Module (720221)

▶ [See here.](#)

13 Math

Computation can be performed on up to 2 Mpoint of data.* (When more than 2 Mpoint of waveform data is displayed, computation is performed on the first 2 Mpoint of data from the computation start point.)
Computed results can be displayed in Math1 to Math8. Waveforms stored through SSD recording cannot be computed.

Math ON/OFF (Mode)

Select whether to use computation.

- ON: Computation is used.
- OFF: Computation is not used.

Real Time Math (/G03, /G05 option)

▶ [See here.](#)

Math Setup (Setup)

Operators and Functions (Operation)

For Math1 to 8, select an operator or function (operation definition) from the options below.

- OFF: Computation is not used.
- $A(S1)+B(S2)+C$: Adds on the waveforms assigned to Source1 and Source2. You can also set coefficients.
- $A(S1)-B(S2)+C$: Subtracts the waveforms assigned to Source1 and Source2. You can also set coefficients.
- $A(S1)*B(S2)+C$: Multiplies the waveforms assigned to Source1 and Source2. You can also set coefficients.
- $A(S1)/B(S2)+C$: Divides the waveforms assigned to Source1 and Source2. You can also set coefficients.
- $\text{Bin}(S1)$: Converts the waveform assigned to Source to binary
- $\text{Shift}(S1)$: Shows the waveform assigned to Source with its phase shifted
- [User Define](#): Performs user-defined math (/G02 option).

Basic Arithmetic with Coefficients ($A(S1)+B(S2)+C$, $A(S1)-B(S2)+C$, $A(S1)*B(S2)+C$, $A(S1)/B(S2)+C$)

Performs addition, subtraction, multiplication, or division with coefficients on the two waveforms assigned to Source1 and Source2.

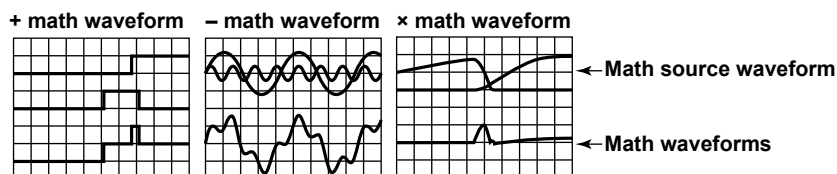

Math Source Waveform (Source1/Source2)

CH1 to CH16,¹ 16chTEMP/VOLT,² CAN,³ LIN,³ SENT,³ RTmath1 to RTmath16, Math1 to Math7⁴

- 1 You can select the channel of an installed module. On a 4-CH module, select sub channel 1 or 2. You cannot select the channel of a logic module.
- 2 When a 16-CH Temperature/Voltage Input Module is installed. Select 16chTEMP/VOLT and then a sub channel.
- 3 On models with the /VCE option when a CAN bus monitor, CAN/CAN FD monitor, CAN & LIN bus monitor, or SENT monitor module is installed. After you select CAN, LIN, or SENT, select a sub channel. This cannot be selected on a CAN bus monitor, CAN/CAN FD monitor, or CAN & LIN bus monitor module if the data type (Value Type) is set to Logic. On a SENT monitor module, S&C and Error Trigger sub channels cannot be selected.
- 4 You can use other Math waveforms as math source waveforms. If you assign the math channel you are setting to MathX, you can select the Math waveforms on channels up to MathX-1. You cannot use another computation waveform as the math source waveform for Math1.



When computation is performed on a linearly scaled channel, the scaled values are used.

Coefficients (A, B, and C)

Set the scaling coefficients (A and B) and the offset (C).

Range: $-9.9999E+30$ to $+9.9999E+30$

Default value of A and B: 1.0000

Default value of C: 0.0000

Unit (Unit)

You can assign a unit of up to four characters in length to the math results. The specified unit is reflected in the scale values.

Label (Label)

You can create a label of up to eight characters in length. The labels that you create are displayed on the screen.

Binary Conversion (Bin (S1))

Using the specified threshold levels, you can convert the waveform assigned to Source to a digital waveform.

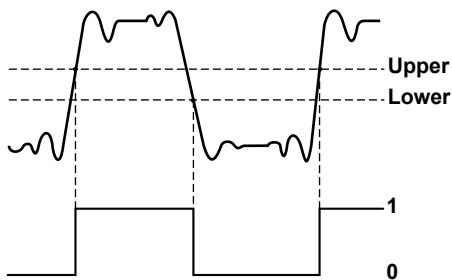
**Math Source Waveform (Source), Unit (Unit), Label (Label)**

This setting is the same as that for basic arithmetic with coefficients.

▶ [See here.](#)

Upper and Lower Thresholds (Thr. Upper/Thr. Lower)

Set the upper and lower threshold values. All values above the upper threshold on the math source waveform are converted to ones, and all values below the threshold are converted to zeros.

Selectable range: -10 div to 10 div (the value unit varies depending on the source waveform type)

Phase Shift (Shift (S1))

You can shift the phase of the waveform assigned to Source, display the resulting waveform, and use the phase-shifted data in computations.

Math Source Waveform (Source), Unit (Unit), Label (Label)

This setting is the same as that for basic arithmetic with coefficients.

▶ [See here.](#)

Shift (Shift)

You can shift waveforms within the following ranges.

- **When the Internal Clock Is Being Used as the Time Base**

Selectable range: Time value between -5 div and 5 div

Step: Sample interval ($1 \div$ sample rate)

The sample rate in Scope mode varies depending on the record length and Time/Div settings. For details, see appendix 2 in the *Getting Started Guide*, IM DL950-03EN. For the sample interval in Recorder mode, see appendix 8 in the *Getting Started Guide*.

- **When an External Clock is Being Used as the Time Base**

Selectable range: $-(\text{record length}/2)$ points to $(\text{record length}/2)$ points

Step: 1

Math Trace Selection (Select Math Trace)

Select the source math waveform to set the [scaling mode](#).

Math1 and Math8

Scaling Mode (Scaling)

Select the method used to set the vertical display range of computed waveforms.

- Auto (Auto): The upper and lower limits are set automatically.
- Manual (Manual): The upper and lower limits must be set manually.

Upper and Lower Limits (Upper/Lower)

Set the upper and lower limits when Scaling Mode is set to Manual.

The selectable range is $-9.9999E+30$ to $9.9999E+30$.

Start Point and End Point (Start Point/End Point)

Set the computation start and end point. The default settings are -5 div $+5$ div.

Selectable range: -5 div to $+5$ div

- Scope mode: Set the positions in divisions.
- Recorder mode: When the time base is internal, set the positions in terms of the time (ddhhmmss) corresponding to divisions. When the time base is external, set the positions in terms of points (0 to record length).

The maximum range from the computation start point to the computation end point varies as indicated below depending on the number of computations.

- One computation: Up to 2 Mpoint
- Two computations: Up to 1 Mpoint
- Three or four computations: Up to 500 kpoint
- Five to eight computations: Up to 250 kpoint

The start and end points are similar to the settable range of the cursor display position in cursor measurement. For details, see "Selectable Range of Cursor Positions."

▶ [See here.](#)



An icon  appears at the top of the screen when computation is being executed. Computation can be performed on the high-speed sampling waveform when dual capture is on.

User-Defined Math Function (User Define)(/G02 option)

Computation can be performed using an expression defined by the user.

If you set the math operation (Operation) to User Define, you can define an expression.

Expression (Expression)

▶ [See here.](#)

Unit (Unit), Label (Label)

This setting is the same as that for basic arithmetic with coefficients.

▶ [See here.](#)

Expression (Expression) (/G02 option)

Define an expression for the user-defined math function by combining math source waveforms, variables, operators, functions, and constants.

Math Source Waveforms and Variables

The following waveforms and variables can be used.

Menu Item	Description
C1 to C16	CH1 to CH16 waveforms
C17 to C32	<ul style="list-style-type: none"> • RTmath1 to RTmath16 waveforms • C17 corresponds to RTmath1; C18 corresponds to RTmath2, . . . , C32 corresponds to RTmath16.
Cn_1 to Cn_16	<ul style="list-style-type: none"> • The waveforms of sub channels 1 to 16 on a 16-CH Temperature/Voltage Input Module • Channel number where n=1, 3, 5, 7, 9, 11, 13, 15
Cn_1 to Cn_60	<ul style="list-style-type: none"> • The waveforms of sub channels 1 to 60 on a CAN Bus Monitor Module • The waveforms of sub channels 1 to 60 on a CAN/CAN FD Monitor Module • The waveforms of sub channels 1 to 60 on a CAN & LIN Bus Monitor Module • Channel number where n = 13 to 16 • You cannot select waveforms whose data type (Value Type) is set to Logic.
Cn_1 to Cn_11	<ul style="list-style-type: none"> • The waveforms of sub channels 1 to 11 on a SENT monitor module • Channel number where n = 9 to 16 • S&C and Error Trigger sub channels cannot be selected.
Cn_1 to Cn_8	<ul style="list-style-type: none"> • Logic module waveforms • Channel number where n = 1 to 16 Specify using the following syntax: Cn_1, upper limit, lower limit.
Cn_1 to Cn_2	<ul style="list-style-type: none"> • The waveforms of sub channels 1 and 2 on a 4-CH module • Channel number where n = 1 to 16
M1 to M7	Math waveforms
T	Integrated data value over time



When computation is performed on a linearly scaled channel, the scaled values are used.

Operators and Functions

The following operators and functions can be used.

Menu Item	Example	Description
+, -, *, /	C1+C2	Displays the result of basic arithmetic of the two specified waveforms.
SHIFT	SHIFT (C1, Time)	Displays the specified waveform with the phase shifted (for internal clock). The unit is seconds.
	SHIFT (C1, Count)	Displays the specified waveform with the phase shifted (for external clock).
ABS	ABS(M1)	Displays the absolute value of the specified waveform
SQRT	SQRT(C2)	Displays the square root of the specified waveform
LOG	LOG(C1)	Displays the logarithm of the specified waveform
EXP	EXP(C1)	Displays the exponent of the specified waveform
NEG	NEG(C1)	Displays the specified waveform inverted around zero.
SIN	SIN(T)	Displays the sine of the specified waveform
COS	COS(C1)	Displays the cosine of the specified waveform
TAN	TAN(C1)	Displays the tangent of the specified waveform
ATAN	ATAN(C1)	Displays the arc tangent of the specified waveform (a value within $\pm \pi$)
PH	PH(C1, C2)	Displays the phase of the specified two waveforms.
DIF	DIF(C1)	Displays the derivative of the specified waveform
DDIF	DDIF(C1)	Displays the second-order derivative of the specified waveform
INTG	INTG(C1)	Displays the integral of the specified waveform
IINTG	IINTG(C1)	Displays the second-order integral of the specified waveform
BIN	BIN (C1, upper limit, lower limit)	Displays the binary value of the specified waveform ¹
P2	P2 (C1)	Displays the square of the specified waveform
P3	P3 (C1)	Displays the cube of the specified waveform
F1	F1(C1, C2)	Displays the $\sqrt{ C1^2 + C2^2 }$ of the specified waveform
F2	F2(C1, C2)	Displays the $\sqrt{ C1^2 - C2^2 }$ of the specified waveform

Menu Item	Example	Description
FV	FV (C1, upper limit, lower limit)	Displays the inverse of the PWHH of the pulse width ¹
PWHH	PWHH (M1, upper limit, lower limit)	Displays the computation of the pulse width between a rising edge and the next rising edge ¹
PWHL	PWHL (C2, upper limit, lower limit)	Displays the computation of the pulse width between a rising edge and the next falling edge ¹
PWLH	PWLH (C1, upper limit, lower limit)	Displays the computation of the pulse width between a falling edge and the next rising edge ¹
PWLL	PWLL (C1, upper limit, lower limit)	Displays the computation of the pulse width between a falling edge and the next falling edge ¹
PWXX	PWXX (C2, upper limit, lower limit)	Displays the computation of the pulse width between a rising/falling edge and the next rising/falling edge ¹
DUTYH	DUTYH (C1, upper limit, lower limit)	Duty cycle of the high side of each period of the specified waveform ¹
DUTYL	DUTYL (C1, upper limit, lower limit)	Duty cycle of the low side of each period of the specified waveform ¹
FILT1	FILT1 (C1)	Displays the specified waveform after applying a filter ²
FILT2	FILT2 (C1)	Displays the specified waveform after applying a filter ²
HLBT	HLBT(C1)	Displays the Hilbert function of the specified waveform
MEAN	MEAN(C1)	Displays the 10th order moving average of the specified waveform

- 1 Set the source waveform and the upper and lower limits of the threshold levels. These are the only functions that can be used on logic module waveforms.
- 2 You can set the filter type in [filter setup](#).

Constants

Menu Item	Description
K1 to K8	You can set the value in constant setup. ► See here .
0 to 9	—
Exp	Exponential input, selectable range: -30 to +30 Used to enter a number in scientific notation in expressions (1E+3 = 1000, 2.5E-3 = 0.0025). Displayed as "E" in expressions to distinguish this from the "EXP" operator.

Constant Setup (Constant(K))

Set values for constants K1 to K8.

The selectable range is -9.9999E+30 to 9.9999E+30.

Automated Measurement Values of Waveform Parameters (Measure)

You can use the automated measurement values of waveform parameters in expressions. The instrument cannot retrieve waveform parameter values when the measurement source waveform display is off.

Configuring Filters (Filter Setup)

When using FILT1 or FILT2 in user-defined computation, set the filter type of two digital filters (FILTER1 and FILTER2), filter band, and cutoff frequency.

Filter Type (Filter Type), Filter Band (Filter Band)

Filter Type (Filter Type)	Filter Band (Filter Band)
Gauss (Gauss)	Low-Pass
Sharp (Sharp)	Low-Pass, High-Pass, Band-Pass
IIR (Butterworth)	Low-Pass, High-Pass, Band-Pass

Cutoff 1 and Cutoff 2 (CutOff1/CutOff2)

Set the cutoff frequencies. If the filter band is Low-Pass or High-Pass, set cutoff 1. If the filter band is Band-Pass, set cutoff 1 and 2.

Selectable range: 2.0 % to 30.0 % of the sample rate

Resolution: 0.2 % steps of the sample rate

Combinations of Operators That Are Not Allowed

- You cannot insert an expression with a larger number than the number of the expression you are defining.
Example: $\text{Math5}=\text{M6}+\text{M3}$
- Expressions containing only constants (K1 to K8) are not allowed.
Example: $\text{Math5}=\text{K1}+\text{K8}$
- An expression cannot contain more than two FILT1 or FILT2 functions.
Example: $\text{FILT1}(\text{C1})+\text{FILT1}(\text{C2})+\text{FILT1}(\text{C3})$
- Other computations cannot be performed on a pulse width computation.
Example: $\text{PWHH}(\text{C1})+\text{C2}$
- When performing SHIFT, pulse width computation, or binary conversion, only a single operator can be used in an expression.
Example, $\text{SHIFT}(\text{C1}+\text{C2})$, $\text{BIN}(\text{C1}-\text{C2})$, $\text{PWHH}(\text{C1}*\text{C1})$
If you want to perform a SHIFT, pulse width computation, or binary conversion on a computed result, such as $\text{C1}+\text{C2}$, define expressions in the following manner: $\text{M1} = \text{C1}+\text{C2}$, $\text{M2} = \text{SHIFT}(\text{M1})$.

Average Setup (Average Setup)(/G02 option)

This is a setting available in Scope mode.

You can average and compute the peak values of computed data.

Average Modes (Average Mode)

The following average modes are available.

- OFF: Averaging is not performed.
- [Linear averaging \(Linear\)](#): Values are averaged linearly.
- [Exponential averaging \(Exp\)](#): Values are averaged exponentially.
- [Cycle averaging \(Cycle\)](#): Values are averaged across cycles.
- [Peak computation \(Peak\)](#): Peak values are computed.

Linear Averaging (Linear)

This is the same feature as the simple average in the FFT average setup.

However, the average domain (Average Domain) is not available.

▶ [See here.](#)

Exponential Averaging (Exp)

This is the same feature as the exponential average in the FFT average setup.

However, the average domain (Average Domain) is not available.

▶ [See here.](#)

Cycle Averaging (Cycle)

The data from the computation start point to the computation end point is divided into the number of data points (Cycle Count) that is specified as being a single cycle, and equivalent points in each divided cycle are averaged with each other. The resulting values are used to display the waveform. The figure below shows the results of cycle averaging when Cycle Count is set to 720.

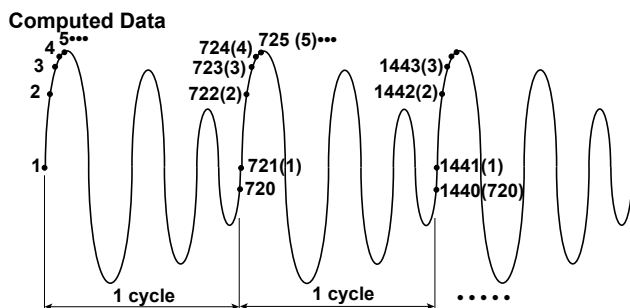

Cycle Averaging Results

Equivalent points in each divided cycle are linearly averaged, and the resulting values are used to display the waveform.

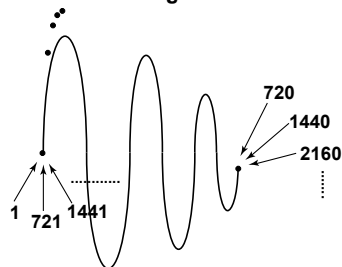

- **Cycle Count (Cycle Count)**

Set the number of data points in one cycle.

Selectable range: 10 to 1800



- All the data between the computation start and end points can be computed. If the data cannot be divided evenly by the specified cycle count, the remaining data is ignored.
- When you execute averaging, after measurement is stopped, computation cannot be restarted. However, computation can be restarted if the number of data points for cycle averaging is changed.

- **Cycle Averaging Example**

When the record length is 10 kpoint, the cycle count is 720, the computation start point is -5.000 div, and the computation end point is $+5.000$ div

$10\text{ k}/720 = 13.88\dots$: 13 cycles are used for the computation.

$13 \times 720 = 9360$: The data from the computation start point (point 1) to point 9360 is included in the cycle average computation.

Peak Computation (Peak)

This is the same feature as the peak computation in the FFT average setup.

However, the average domain (Average Domain) is not available.

▶ [See here.](#)

Notes about Computation

- An icon  appears at the top of the screen when a user-defined math function is being executed.
- Waveforms stored through SSD recording cannot be computed.

Notes about Using the 16-CH Temperature/Voltage Input Module (720221)

▶ [See here.](#)

14 GO/NO-GO Determination (Scope mode only)

The instrument determines whether the acquired waveform meets the reference condition (GO result) or not (NO-GO result). When the instrument produces a GO or NO-GO result, it executes the specified actions.

GO/NO-GO ON/OFF Determination (Mode)

Select whether to perform GO/NO-GO determination.

- ON: GO/NO-GO is performed.
- OFF: GO/NO-GO is not performed.

Determination Type Selection (Type)

Select the GO/NO-GO determination type from the following.

- [Waveform zone \(Wave Zone\)](#): GO/NO-GO determination is performed in the waveform zone set on the screen.
- [Waveform parameter \(Parameter\)](#): GO/NO-GO determination is performed using the settings of the specified waveform parameters.

Waveform Zone (Wave Zone)

The instrument returns GO/NO-GO results based on whether waveforms leave or enter the zone that you create using a base waveform.

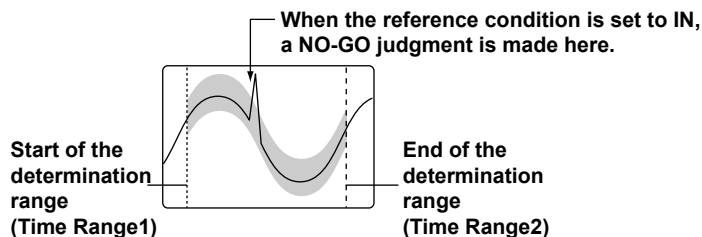

Waveform Zone Selection (Zone Select)

Select the number of the waveform zone you want to edit from the range indicated below.

Zone 1 to Zone 6 (Zone1 to Zone6)

If a zone has already been created for that number, the zone will be displayed. If no zone has been created for a number, select a base waveform from the base waveform editing menu (New), and then edit the zone.

Waveform Zone Editing (Zone Edit)

Base Waveform Selection (New)

When you create a new waveform zone, you need to select the waveform that you will base it on (the base waveform). Select a waveform whose display is on.

CH1 to CH16¹, Math1 to Math8

- 1 You can select the channel of an installed module. On a 4-CH module, select sub channel 1 or 2. However, you cannot select the channels of a logic module, 16-CH Temperature/Voltage Input Module, CAN Bus Monitor Module, CAN/CAN FD Monitor, CAN & LIN Bus Monitor, or SENT Monitor Module.

Editing Range Specification (Zone Edit)

Select the part of the base waveform that you want to edit.

- Whole (Whole): The whole waveform is within the editing range.
- Part (Part): A portion of the waveform is within the editing range.

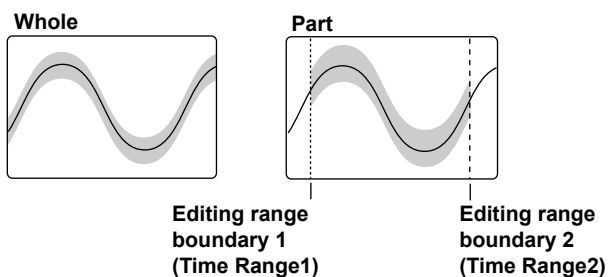

Zone Settings

When Edit is set to Whole, you can set the upper, lower, left, and right boundaries of the waveform zone. When Edit is set to Part, you can set the upper and lower boundaries of the zone.

- Upper and Lower Limits (Upper/Lower)
 - Selectable range: ± 10 div vertically from the base waveform
 - When Edit is set to Part, you can set the upper and lower boundaries of the area between Time Range1 and Time Range2.
- Left and right sides (Left and Right): These settings can be configured only when Edit is set to Whole.
 - Selectable range: ± 5 div from the center of the screen
- Time range 1 and time range 2 (Time Range1 and Time Range2): These settings can be configured only when Edit is set to Part.
 - Selectable range: ± 5 div on the time axis

Save Destination (Store as)

You can select one of the following save destinations for the waveform zone.

Zone 1 to Zone 6 (Zone1 to Zone6)

Saving a Waveform Zone (Store Exec)

Save the waveform zone.

Finishing the Editing Operation (Quit)

Finish waveform zone editing. The edited zone will be lost if you do not save it by pressing the Save (Execute Store) soft key.

Judgment Conditions (Judgement Setup)

For each of the 16 judgment conditions, you can set the source waveform, zone number, and judgment criterion. You can also set the judgment logic, action condition, sequence, acquisition count, and external start.

Judgment Criterion (Mode)

Select the judgment criterion from the following options.

- X: The condition is not used for GO/NO-GO determination.
- IN: The instrument returns a GO result when the source waveform is within the GO/NO-GO determination zone. If even a part of the source waveform is outside of the determination zone, the instrument returns a NO-GO result.
- OUT: The instrument returns a GO result when the entire source waveform is outside the GO/NO-GO determination zone. If even a part of the source waveform is inside the determination zone, the instrument returns a NO-GO result.

Source Waveform (Trace)

Set the waveform to use for GO/NO-GO determination to one of the waveforms below.

CH1 to CH16,* Math1, or Math8

- * You can select the channel of an installed module. On a 4-CH module, select sub channel 1 or 2. However, you cannot select the channels of a logic module, 16-CH Temperature/Voltage Input Module, CAN Bus Monitor Module, CAN/CAN FD Monitor, CAN & LIN Bus Monitor, or SENT Monitor Module.

Zone Number (Zone No.)

Select the number of the waveform zone you want to use for GO/NO-GO determination from the range indicated below.

Zone 1 to Zone 6 (Zone1 to Zone6)

Determination Logic (Logic)

You can select the determination logic from the following options.

- AND: The actions are performed when all the conditions from 1 to 16 are met.
- OR: The actions are performed when a condition from 1 to 16 is met.

Action Condition (ActCondition)

Set the action condition to one of the settings below.

- Always (Always): The actions are always performed. The actions will be executed each time the instrument triggers.
- At failure (Fail): The actions are executed when the specified GO conditions are not met.
- At success (Success): The actions are executed when the specified GO conditions are met.

Sequence (Sequence)

Select the sequence for executing actions.

- Single (Single): Execution stops after the actions are performed once.
- Continue (Continue): Actions are executed repeatedly. However, the actions stop repeating after the specified number of waveform acquisitions (the Acquisition Count setting). If Acquisition Count is set to Infinite, the actions continue until waveform acquisition is stopped with the START/STOP key.

14 GO/NO-GO Determination (Scope mode only)

Acquisition Count (Acquisition Count)

Set the number of waveform acquisitions.

- Infinite: Waveform acquisition continues until it is stopped with the START/STOP key.
- 1 to 65536: The instrument stops acquiring waveforms after it acquires the specified number of waveforms.

External Start (Remote)

You can perform GO/NO-GO determination and output the results in sync with an external signal applied to the START terminal of this instrument.

- OFF: GO/NO-GO determination is not performed through the use of an external signal.
- ON: GO/NO-GO determination is performed through the use of an external signal.

Action Condition (ActCondition)

This is the same as the action setting on the ACTION menu. Measured values cannot be saved if GO/NO-GO judgment is turned on.

▶ [See here.](#)

Determination Period (Time Range1/Time Range2)

You can set the determination period by setting Time Range1 and Time Range2. The default settings are -5 div +5 div. The selectable range is -5 div to +5 div. The start and end points are similar to the settable range of the cursor display position in cursor measurement. For details, see "Selectable Range of Cursor Positions."

▶ [See here.](#)

GO/NO-GO Determination Results

The results of GO/NO-GO determination (and the numbers of determinations and failures) appear at the bottom of the screen.

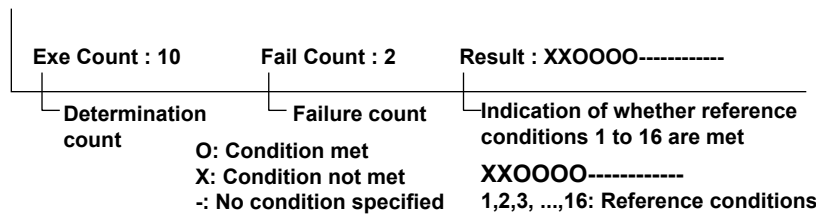

In this example, reference conditions 1 and 2 are not met while the conditions defined by base waveforms 3 to 6 are met.

Waveform Parameter (Parameter)

Upper and lower limits for automated measurement of waveform parameters are set, and GO/NO-GO determination is performed on whether the parameters are within or outside the range.

Judgment Conditions (Judgement Condition)

For each of the 16 judgment conditions, you can set the source waveform, waveform parameter, upper and lower limits of the waveform parameter, and judgment criterion. You can also set the judgment logic, action condition, sequence, acquisition count, and external start.

Judgment Criterion (Mode)

Select the judgment criterion from the following options.

- X: The condition is not used for GO/NO-GO determination.
- IN: The instrument returns a GO result when the value is within the specified upper and lower limits. Otherwise, the instrument returns NO-GO.
- OUT: The instrument returns a GO result when the value is outside the specified upper and lower limits. Otherwise, the instrument returns NO-GO.

Source Waveform (Trace)

Set the waveform to use for GO/NO-GO determination to one of the waveforms below.

CH1 to CH16,* RTmath1 to RTmath16, FFT1 to FFT8, Math1 to Math8

- * You can select the channel of an installed module. On a 4-CH module, select sub channel 1 or 2. However, you cannot select the channels of a 16-CH Temperature/Voltage Input Module, CAN Bus Monitor Module, CAN/CAN FD Monitor, CAN & LIN Bus Monitor, or SENT Monitor Module.

Waveform Parameter (Item)

You can use all automatically measured waveform parameters as judgment conditions. You can perform GO/NO-GO determination on up to 16 parameters at the same time.

▶ [See here.](#)

Upper and Lower Parameter Limits (Upper/Lower)

Selectable range: $-9.9999E+30$ to $9.9999E+30$

Determination Logic (Logic), Action Condition (ActCondition), Sequence (Sequence), Acquisition Count (Acquisition Count), External Start (Remote)

▶ [See here.](#)

Action Condition (ActCondition)

This is the same as the action setting on the ACTION menu. Measured values cannot be saved if GO/NO-GO judgment is turned on.

▶ [See here.](#)

Determination Period (Time Range1/Time Range2)

▶ [See here.](#)

GO/NO-GO Determination Results

The results of GO/NO-GO determination (and the numbers of determinations and failures) appear at the bottom of the screen.

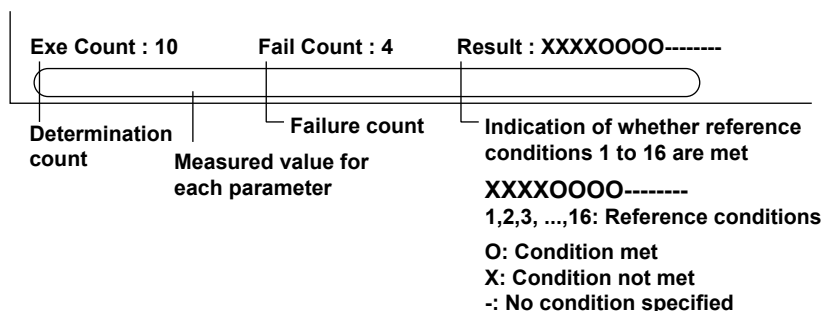

In this example, reference conditions 1 and 4 are not met while the conditions defined by reference conditions 5 to 8 are met.

Notes about GO/NO-GO Determination

- During determination, all keys other than START/STOP are invalid.
- When performing GO/NO-GO determination with waveform zones you cannot start measurement if the number of waveform data points (record length) to be acquired is less than 2000.
- The determination interval is synchronized to the trigger. However, while actions are being performed after a determination, the instrument will not trigger.
- While you are accessing the instrument through the FTP or Web server, if one of the following operations is performed, actions cannot be executed until you finish accessing the instrument.
 - Saving of screen capture data and saving of waveform data

Notes about the “Save Data” and “Save Image” Actions

▶ [See here.](#)

Notes about Using the 16-CH Temperature/Voltage Input Module (720221)

▶ [See here.](#)

15 Actions

If the action mode or Save on Stop is set to ON, the specified action (operation) is performed in the following situations.

Scope Mode

- **When Dual Capture Mode Is Off**

- When the instrument triggers, and the corresponding waveform acquisition stops
- When the action condition of GO/NO-GO determination is met
- When waveform acquisition stops

However, if the trigger mode is set to Single N, the instrument cannot start waveform acquisition when the action mode is set to ON.

- **When Dual Capture Mode Is On**

- When a trigger occurs and high-speed sampling waveform is acquired
- When waveform acquisition stops

Recorder Mode

- When waveform acquisition stops

Settings

Scope Mode

- [Action mode](#)
- [Action settings](#)

Recorder Mode

- [Save on Stop](#)
- [Save on Stop settings](#)

Action Mode (Mode)

This is a setting available in Scope mode. Select whether to execute actions.

When dual capture is on, this is synchronized to the action on/off setting, shown by pressing the ACQUIRE key.

- OFF: Actions are not executed.
- ON: Actions are executed.

Action Setup (Action Setup)

This is a setting available in Scope mode. Select the action from the following.

Save Waveform Data (Save Waveform)

The selected data types of waveform data are saved to the specified destination.

- **When Dual Capture Mode Is Off**

Select the data types from binary (Binary), ASCII (ASCII), and MATLAB. You can select multiple types.

- **When Dual Capture Mode Is On**

Select the data types from all data binary (Binary), high-speed sampling binary (Binary), low-speed sampling ASCII (ASCII), high-speed sampling ASCII (ASCII), low-speed sampling MATLAB, and high-speed sampling MATLAB. You can select multiple types.



Set the details of the waveform data to be saved (detailed waveform save settings and save trace selection) on the menu that appears by pressing the FILE key (save waveform data).

Save Screen Capture (Save Image)

Saves screen capture data to the specified destination.

Type (Type)

Set the file format of the screen capture data to be saved to PNG, BMP, or JPEG.

▶ [See here.](#)



Set the details (color, background) of the screen capture data to be saved on the menu that appears by pressing the FILE key (save waveform data).

Save Measured Values (Measure Value Save)

You can save the results of the automated measurement of waveform parameters to a file in CSV format at the save destination.



Set the details of the measured data to be saved (Save Measured Values) on the menu that appears by pressing the FILE key (save measured data).

Save Setup (Save Setup)

File Path (File Path)

This is a setting for when synchronous operation is not being performed in multi-unit synchronization mode (/C50 option). Specify the file save destination for the waveform data, screen capture data, and measure data saved by the action feature.

▶ [See here.](#)

Save Destination in Multi-Unit Synchronization Mode (/C50 option) (Destination)

This is a setting for when synchronous operation is being performed in multi-unit synchronization mode (/C50 option). Specify the data save destination device (SD-1, USB-0/USB-1, Internal, Network). You cannot specify a sub folder in a storage device.

When you specify the save destination device, a fixed area (REMOTE) is automatically created in its root directory.

Auto Date Folder Creation (Create Date Folder)

Set whether to automatically create date folders (folders with a year, month, and day in their names).*

- ON: Date folders are created automatically, and data when actions are executed are saved.
If the number of files in the save destination folder exceeds 1000, a new folder is automatically created with the date and an incremented sequence number (000 to 999) as its name, and the data continues to be saved in the new folder.
- OFF: Date folders are not created automatically.
 - The maximum number of files that can be saved to a single folder is 1000. If you specify a folder created manually for the save destination, check that there are no files in the save destination folder before actions are executed.
 - If the measurement count (Acquisition Count) is set to a number greater than 1000, the measurement cannot be started. ▶ [See here.](#)

* In multi-unit synchronization mode (/C50 option), date_time folders are created in a fixed area (REMOTE).

Auto Naming (Auto Naming), File Name (File Name)

The auto naming and file name settings are synchronized to the settings accessed from the menu that opens with the FILE key. You can set the auto naming method to serial numbers or dates.

▶ [See here.](#)

Beep (Beep)

Sounds an alarm.

Send Mail (Send Mail)

The instrument sends an e-mail to the specified address. Set the e-mail address by pressing UTILITY and then selecting Network > Mail.

▶ [See here.](#)

E-mail Send Count (Mail Count)

Set the number of e-mail transmissions.

- Infinite: E-mail continues to be transmitted until you stop the action.
- 1 to 1000: E-mail transmission stops when the number of sent e-mails reaches the specified count.



In recorder mode, the number of e-mail transmissions is 1. As such, the above settings are not displayed.

Save on Stop (Save on Stop)

This is a setting available in Recorder mode.

- OFF: Actions are not executed. The acquisition mode changes to Memory on the menu that appears by pressing the ACQUIRED key.
- ON: Actions are executed. The acquisition mode changes to Memory+Save on Stop on the menu that appears by pressing the ACQUIRED key.

Save on Stop Setup (Save on Stop Setup)

This is a setting available in Recorder mode.

This is the same setting as the action setting and Scope mode. However, for the waveform data save formats, select from binary, ASCII, and MATLAB (multiple selections allowed).

▶ [See here.](#)

Notes about Action

- You cannot change settings while the action feature is active.
- The actions may be slow if there is network access while the following operations are being performed.
 - Printing and saving of screen capture data and saving of waveform data
- When SSD recording is enabled, the action feature cannot be used.

Notes about the “Save Data” and “Save Image” Actions

- Do not set the storage device’s root folder as the save destination. The instrument can only store 512 files to the root folder of a storage device that the instrument has formatted. A file whose name is longer than eight characters will be counted as two files. If such files exist, the number of files that can be stored will decrease.
- On the FILE menu, if you set Auto Naming to Numbering, as the number of saved files increases, the amount of time required to save a file will also increase.
- Action for dual capture

When waveform acquisition is finished or when high-speed sampling waveform is acquired due to a trigger, the instrument executes the preset action. For the timings when actions are executed, see “Dual Capture (DUAL CAPTURE, Scope mode only)” in chapter 3.

▶ [See here.](#)



You can select whether to enable actions at power-on.

▶ [See here.](#)

16 Real Time Math (/G03, /G05 option)

Real Time Math Channel ON/OFF (Input)

Set whether to acquire waveforms in real time math channels.

- ON: Waveforms are acquired in real time math channels.
- OFF: Waveforms are not acquired in real time math channels.

On models with the /G03 or /G05 option, you can perform real time math operations in which the waveforms of input channels or the results of other real time math operations are used as the math source waveforms. Another feature of the /G03 or /G05 option is the [digital filter](#).

- You can perform math operations on up to 16 channels at the same time. Real time math can be specified for each channel separately.
- Real time math results are output to real time math channels (RT.MATH CH).
- Waveforms of real time math channels (real time math results) are used for displaying, saving, triggering, and analyzing (except for power math).
- Other real time math channels can be used as source waveforms of real time math. If you set the real time math channel to RTmathX, you can select the RTmath waveforms on channels up to RTmathX-1. If the real time math channel is RTmath1, you cannot select another real time math channel.
- The input channel of a 16-CH temperature/voltage input, CAN bus monitor,* CAN/CAN FD monitor,* CAN & LIN bus monitor,* SENT monitor, or 4CH module can be used as a source waveform of real time math.
 - * To use an input channel as a source waveform, set Input to ON in All Sub Channel Setup (All Sub Channel Setup) of CAN Port Configuration or LIN Port Configuration.
- For power math on the /G05 option, the power analysis results are output to RTmath13 and RTmath14, and harmonic analysis results are output to RTmath15 and RTmath16.
- For details on the modules whose channels you can set as real time math sources, see “Notes Regarding Using the Digital Filter and Real Time Math.”
 - ▶ [See here.](#)
- Even during waveform acquisition, you can set various math conditions, such as operators and functions (math operations), the source waveforms, and the coefficients. However, if you change the conditions, the measurement count (waveform acquisition count) is reset. The measurement count is displayed in the lower left of the screen. In roll mode during waveform acquisition, real time math cannot be turned on and off.
- For details on the math expressions, delay, and settings, see appendix 11..
- Math operations are performed in floating point format, and the results are also saved in this format.
- Since results are recorded in floating point format, the math results can be redisplayed with any scale using the scale knob.
- The math results are recorded in the acquisition memory in a different area from the input channels. Therefore, if real time math is used, the memory length per channel is reduced. For details, see appendix 1 in the *Getting Started Guide*, IM DL950-03EN.

Label (Label)

- ▶ [See here.](#)

Real Time Math Setup (RealTime Math Setup)

- ▶ [See here.](#)

Bandwidth Limit (Bandwidth)

An IIR-Lowpass filter can be applied to the computer results. For the filter response, see appendix 11.

Settings: Full, 128 kHz, 64 kHz, 32 kHz, 16 kHz, 8 kHz, 4 kHz, 2 kHz, 1 kHz, 500 Hz, 250 Hz, 125 Hz, 62.5 Hz

- ▶ [See here.](#)

Vertical Scale (SCALE knob)

Sets Value/Div.

Waveform Vertical Position (Vertical POSITION knob)

Real time math waveforms can be moved vertically.

Scaling (Scaling)

Set the display range (upper and lower limits) of the real time math waveforms using one of the following methods. Changing the display range causes Value/Div to change accordingly.

- **Upper and Lower Limits (Upper/Lower)**
Set the display range (upper and lower limits) with the jog dial or numerical input.
- **Auto Scale (Auto Scale)**
Sets the display range automatically from the input level of the math source waveform.
- **Default Scale (Default Scale)**
Sets a display range deemed appropriate from the setting range and expression of the math source waveform.

Assignments to Display Groups (Display)

▶ [See here.](#)

Manual Reset (Manual Reset)

You can set this when math is defined as follows. You can also set this on the real time math setup window.

[Integ1\(S1\)](#), [Integ2\(S2\)](#), [Rotary Angle](#), [Power Integ](#), [Cos](#), [Sin](#), [Edge Count](#)

Unit (Unit)

You can assign a unit using up to four characters in length to the math results. The specified unit is reflected in the scale values.

Sample Rate (Sample Rate), Sample Interval (Sample Interval)

▶ [See here.](#)

All Channels Setup Menu

There is a menu (ALL CH) that is used to configure the settings for all channels for real time math. The menu is operated in the same way as the [all channels setup menu](#) on the standard model.

- You can configure the real time math settings of all channels while viewing the settings in a list.
- You can turn real time math on and off for all channels at once.
- There are some items that cannot be configured from the ALL CH menu.

Real Time Math Setup (RealTime Math Setup)

Select the operator or function (math operation), and then set its corresponding items.

Operators and Functions (Operation)

- **A(S1)+B(S2)+C**: Performs addition with coefficients on the waveforms assigned to Source1 and Source2
- **A(S1)-B(S2)+C**: Performs subtraction with coefficients on the waveforms assigned to Source1 and Source2
- **A(S1)*B(S2)+C**: Performs multiplication with coefficients on the waveforms assigned to Source1 and Source2
- **A(S1)/B(S2)+C**: Performs division with coefficients on the waveforms assigned to Source1 and Source2
- **Diff(S1)**: Performs differentiation on the waveform assigned to Source using a fifth order Lagrange interpolation formula
- **Integ1(S1)**: Performs integration on the positive component of the waveform assigned to Source
- **Integ2(S1)**: Performs integration on the positive and negative components of the waveform assigned to Source
- **Rotary Angle**: Uses the waveforms or logic signals that have been assigned to phases A, B, and Z to calculate the angle of rotation. This can be used to calculate the angle of rotation or the displacement of an encoder.
- **Rotary Speed**: Uses the waveforms or logic signals that have been assigned to phases A and B to calculate the rotating speed.
- **DA**: Converts the logic signals that have been assigned to Source1 (the least significant digits) and Source2 (the most significant digits) into an analog waveform and scales the results
- **Polynomial**: Performs a quartic polynomial calculation on the waveform that has been assigned to Source
- **RMS**: Calculates the RMS value of the waveform that has been assigned to Source
- **Power**: Calculates the effective power of the waveforms that have been assigned to Source1 and Source2
- **Power Integ**: Calculates the effective power of the waveforms that have been assigned to Source1 and Source2
- **Log1**: Calculates the common logarithm of the waveforms that have been assigned to Source1 and Source2 (the calculation is performed on "Source1/Source2").
- **Log2**: Calculates the common logarithm of the waveform that has been assigned to Source.
- **Sqrt1**: Calculates the square root of the sum (or difference) of the squares of the waveforms that have been assigned to Source1 and Source2. This can be used to analyze displacement and tolerance.
- **Sqrt2**: Calculates the square root of the waveform that has been assigned to Source
- **Cos**: Uses the waveforms or logic signals that have been assigned to phases A, B, and Z to determine the angle, and then calculates the cosine of this angle. You can use this to convert the angle to displacement.
- **Sin**: Uses the waveforms or logic signals that have been assigned to phases A, B, and Z to determine the angle, and then calculates the sine of this angle. You can use this to convert the angle to displacement.
- **Atan**: Calculates the arc tangent of the waveforms that have been assigned to Source1 and Source2 (the calculation is performed on "Source1/Source2"). You can use this to convert the displacement to an angle.
- **Electrical Angle**: Calculates the phase difference between (1) the angle that was determined from the logic signals that were specified for phases A, B, and Z, and (2) the fundamental component that was determined from the discrete Fourier transform of the waveform that was specified as the target (Target). You can calculate the phase difference (electrical angle) between the motor's angle of rotation and the motor drive current.
- **Knock Filter** (available only for the /VCE option): When the signal level of the waveform that has been set to Source is less than or equal to the elimination level, the signal of this waveform is set to 0. You can select whether to perform differentiation. You can use this to extract knocking.
- **Poly-Add-Sub**: Performs addition or subtraction or both on the waveforms that have been set to Source1, Source2, Source3, and Source4.
- **Frequency**: Calculates the frequency of the waveform that has been assigned to Source
- **Period**: Calculates the period of the waveform that has been assigned to Source
- **Edge Count**: Counts the number of slope edges of the waveform that has been assigned to Source. You can use this to count the number of events in consecutive tests.
- **Resolver**: Calculates the angle of rotation from the sine signal and cosine signal that are generated from the detection coil of the resolver depending on the angle of the rotor.
- **PWM**: Integrates a pulse width modulation signal and demodulates it to an analog signal.
- **Torque**: Measures the frequency of the pulse frequency output torque sensor and calculates the torque using the specified coefficient.
- **3 Phase Resolver**: Calculates the angle of rotation from the two sine signals that are generated from the detection coil of the 3 phase resolver depending on the angle of the rotor.

Basic Arithmetic with Coefficients (A(S1)+B(S2)+C, A(S1)-B(S2)+C, A(S1)*B(S2)+C, A(S1)/B(S2)+C)

Performs addition, subtraction, multiplication, or division with coefficients on the two waveforms assigned to Source1 and Source2.

Math Source Waveforms (Source1 and Source2)

CH1 to CH16,¹ 16chTEMP/VOLT,² CAN,³ LIN,³ SENT,³ RTmath1 to RTmath15⁴

- 1 You can select the input channel of an installed module. On a 4-CH module, select sub channel 1 or 2. You cannot select the input channel of a logic module.
- 2 When a 16-CH Temperature/Voltage Input Module is installed. Select 16chTEMP/VOLT and then a sub channel.
- 3 On models with the /VCE option when a CAN bus monitor, CAN/CAN FD monitor, CAN & LIN bus monitor, or SENT monitor module is installed. After you select CAN, LIN, or SENT, select a sub channel. This cannot be selected on a CAN bus monitor, CAN/CAN FD monitor, or CAN & LIN bus monitor module if the data type (Value Type) is set to Logic. Even if the data type is not set to Logic, you cannot use data that exceeds 16 bits in length. On a SENT monitor module, S&C and Error Trigger sub channels cannot be selected.
- 4 You can use other RTmath waveforms as math source waveforms. If you set the real time math channel to RTmathX, you can select the RTmath waveforms on channels up to RTmathX-1. If the real time math channel is RTmath1, you cannot select another real time math channel.

▶ [See here.](#)

Coefficients (A, B, and C)

Set the scaling coefficients (A and B) and the offset (C).

Selectable range: -9.9999E+30 to +9.9999E+30, in 1E-30 steps

Default values of A and B: 1.0000

Default value of C: 0.0000

Differentiation (Diff(S1))

Performs differentiation on the waveform assigned to Source using a fifth order Lagrange interpolation formula. For details on the differentiation characteristics, see appendix 11.

Math Source Waveforms (Source)

The options are the same as were described for basic arithmetic with coefficients.

▶ [See here.](#)

Calculation Period (Calc Period)

Selectable range: 10 MHz to 1 Hz (in 1-2-5 steps)

Set the calculation period to a value less than the sampling frequency of the source signal. This will produce a smooth differential waveform.

Integration (Integ1(S1) and Integ2(S1))

Integration is performed on the waveform that has been assigned to Source.

- Integ1(S1): Performs integration on the positive component of the waveform assigned to Source
- Integ2(S1): Performs integration on the positive and negative components of the waveform assigned to Source

Math Source Waveforms (Source)

The options are the same as were described for basic arithmetic with coefficients.

▶ [See here.](#)

Reset Condition (Reset Condition)

Select the condition for resetting integration from one of the settings below.

- Start (Start): When the waveform acquisition starts
- Over limit (Overlimit): When the specified over-limit value is exceeded.
- Over limit value (OverlimitValue): Set the limit value when over limit is set to ON.
Selectable range: $-9.9999E+30$ to $+9.9999E+30$, in $1E-30$ steps
- Zero crossing (ZeroCross): When the math source waveform signal crosses zero
Set the slope direction (positive or negative) and the hysteresis when the signal crosses zero. The hysteresis level is the same as the trigger hysteresis. ▶ [See here.](#)

Manual Reset (Manual Reset)

To manually reset the integration, select Execute.

Angle of Rotation (Rotary Angle)

The angle of rotation is calculated using the waveforms or logic signals that have been assigned to phases A, B, and Z. This can be used to calculate the angle of rotation or the displacement of an encoder.

Type (Type)

You can select the type of the encoding from the following options.

- Incremental ABZ (Incremental ABZ): The angle of rotation is calculated from the A, B, and Z phase signals.
- Incremental AZ (Incremental AZ): The angle of rotation is calculated from the A and Z phase signals.
- Absolute 8 bit (Absolute 8bit): The angle of rotation is calculated from an 8-bit logic signal (binary code).
- Absolute 16 bit (Absolute 16bit): The angle of rotation is calculated from a 16-bit logic signal (binary code).
- Ray code (Gray Code): The angle of rotation is calculated from the 2- to 16-bit logic signal (gray code).
- Incremental AB (Incremental AB): The angle of rotation is calculated from the A and B phase signals.
- Incremental A (Incremental A): The angle of rotation is calculated from the A phase signal.

Source Conditions (Source Condition)

Set the conditions of the source whose pulses you want to count.

When the type of the encoding is ABZ, AZ, AB, or A

- **Logic Source ON/OFF (Logic Source)**

- ON: You can set the A, B, and Z phase signals to the signals of logic modules.
- OFF: You can set the A, B, and Z phase signals to the signals of analog waveform modules.
The options are the same as were described for basic arithmetic with coefficients. However, you cannot select the input channels of frequency modules or real time math channels (RTMath). ► [See here.](#)

- **When logic sources are turned on**

- Source (Source): Select an input channel of a logic module.
- Phase A (Phase A): Select the bit that you want to use for the phase A signal from among the logic signals of the selected input channel.
- Phase B (Phase B): Select the bit that you want to use for the phase B signal from among the logic signals of the selected input channel.
- Phase Z (Phase Z): Select the bit that you want to use for the phase Z signal from among the logic signals of the selected input channel. You can also select whether the phase Z input is inverted.

- **When logic sources are turned off**

Set the input channels for the phase A, B, and Z signals,¹ the signal level of each signal that you will count as a pulse,² and the hysteresis of each signal.³

- Phase A (Phase A): Set the input channel, signal level, and hysteresis of the phase A signal.
- Phase B (Phase B): Set the input channel, signal level, and hysteresis of the phase B signal.
- Phase Z (Phase Z): Set the input channel, signal level, and hysteresis of the phase Z signal. You can also select whether the phase Z input is inverted.

To set the timing that pulses are counted and the timing that the pulse count is reset for the signal level that you set here, see "Encoding Conditions" later in this section. ► [See here.](#)

- 1 The options are the same as were described for basic arithmetic with coefficients. However, you cannot select the input channels of frequency modules or real time math channels (RTMath). ► [See here.](#)
- 2 The signal level range is the same as the trigger level range. ► [See here.](#)
- 3 The hysteresis level is the same as the trigger hysteresis. ► [See here.](#)

If the type of the encoding is absolute 8 bit , absolute 16 bit, or gray code

Select the input channel of the logic module. For absolute 16 bit and gray code* encoding, set the logic channel for the least significant digits to Source1 and the logic channel for the most significant digits to Source2.

- * When the gray code bit length is 8 or less, the Source2 setting is ignored.

Pulses per Rotation (Pulse/Rotate)

When the encode type is not gray code, set the number of pulses per rotation.

Selectable range: 1 to 500000. The default setting is 180.

However, if the encode type is absolute 8 bit, the maximum number is 256. If the type is absolute 16 bit, the maximum is 65536.

Bit Length (Bit Length)

When the encode type is gray code, set the bit length.

Selectable range: 2 to 16

Scaling (Scaling)

Select the unit that is used on the vertical scale.

- Radian: Radian
- Degree: Degrees
- User-defined (User Define): Set K, the size of the scale.
Selectable range: $-9.9999E+30$ to $+9.9999E+30$. The default setting is 1.0000.

Negative Logic ON/OFF (Negative logic)

When the encode type is absolute 8 bit , absolute 16 bit, or gray code, select which bit state will be recognized to be logic 1.

- ON: Negative logic (low state is logic 1)
- OFF: Positive logic (high state is logic 1)

Encoding Conditions (Encode Condition)

If the type of the encoding is ABZ, AZ, AB, or A, set the encoder's pulse multiplier and the timing (edge) for counting pulses.

Count Conditions (Count Condition)

You can select the encoder's pulse multiplier from the following options.

x4, x2, x1

When the multiplier is x4, regardless of the timing setting made in the next section, pulses are counted on all the edges of the signal.

Timing1 (Timing1)

Select the edges that are counted as pulses when the multiplier is x1.

- A \uparrow : Rising edge of the phase A signal
- A \downarrow : Falling edge of the phase A signal
- B \uparrow : Rising edge of the phase B signal
- B \downarrow : Falling edge of the phase B signal

Rising edge: The point where the signal rises from a low level and passes through the specified signal level

Falling edge: The point where the signal falls from a high level and passes through the specified signal level

If the signal is that of an analog waveform, turn the logic sources off as shown earlier this manual in "Source Conditions," and then set the signal level that is counted as a pulse and the hysteresis. ► [See here.](#)

Timing2 (Timing2)

Select the edges that are counted as pulses when the multiplier is x2. The options are the same as were described above for Timing1.

When the multiplier is x2, if you select the same edges as in Timing1, the pulse count conditions are the same as were explained for multiplier x1.

Reset Timing (Reset Timing)

Select the timing (edge) at which the pulse count will be reset.

- A \uparrow : Rising edge of the phase A signal
- A \downarrow : Falling edge of the phase A signal
- B \uparrow : Rising edge of the phase B signal
- B \downarrow : Falling edge of the phase B signal
- Z level (Z Level): When the Z phase signal is at a high level.

Reverse (Reverse)

Set the direction that the angle of rotation increases in.

- ON: The rotation is counter-clockwise.
- OFF: The rotation is clockwise.

Manual Reset (Manual Reset)

To manually reset the angle of rotation, select Execute.

Rotating Speed (Rotary Speed)

The angle of rotation is calculated using the waveforms or logic signals that have been assigned to phases A and B. Deceleration prediction and stop prediction of the encoder are also possible.

Type (Type)

The encode type is fixed to Incremental AB (Incremental AB).

The rotary speed is calculated from the A and B phase signals.

Source Conditions (Source Condition)

Set the conditions of the source whose pulses you want to count.

- **Logic Source ON/OFF (Logic Source)**

- ON: You can set the A and B phase signals to the signals of logic modules.
- OFF: You can set the A and B phase signals to the signals of analog waveform modules.
The options are the same as were described for basic arithmetic with coefficients. However, you cannot select the input channels of frequency modules or real time math channels (RTMath). ► [See here.](#)

- **When logic sources are turned on**

- Source (Source): Select an input channel of a logic module.
- Phase A (Phase A): Select the bit that you want to use for the phase A signal from among the logic signals of the selected input channel.
- Phase B (Phase B): Select the bit that you want to use for the phase B signal from among the logic signals of the selected input channel.

- **When logic sources are turned off**

Set the input channels for the phase A and B signals,¹ the signal level of each signal that you will count as a pulse,² and the hysteresis of each signal.³

- Phase A (Phase A): Set the input channel, signal level, and hysteresis of the phase A signal.
- Phase B (Phase B): Set the input channel, signal level, and hysteresis of the phase B signal.

To set the timing that pulses are counted and the timing that the pulse count is reset for the signal level that you set here, see "Encoding Conditions" later in this section. ► [See here.](#)

- 1 The options are the same as were described for basic arithmetic with coefficients. However, you cannot select the input channels of frequency modules or real time math channels (RTMath). ► [See here.](#)
- 2 The signal level range is the same as the trigger level range. ► [See here.](#)
- 3 The hysteresis level is the same as the trigger hysteresis. ► [See here.](#)

Pulses per Rotation (Pulse/Rotate)

Set the number of pulses per rotation.

Selectable range: 1 to 99999. The default setting is 1.

Scaling (Scaling)

Select the unit that is used on the vertical scale.

- Hz: Hertz
- Rpm: Rotation per minute
- User-defined (User Define): Set K, the size of the scale.
Selectable range: $-9.9999E+30$ to $+9.9999E+30$. The default setting is 1.0000.

Encoding Conditions (Encode Condition)

Set the encoder's pulse multiplier and pulse count timing (edge).

Count Conditions (Count Condition)

You can select the encoder's pulse multiplier from the following options.

x4, x2, x1

When the multiplier is x4, regardless of the timing setting made in the next section, pulses are counted on all the edges of the signal.

Timing1 (Timing1)

Select the edges that are counted as pulses when the multiplier is x1.

- A \uparrow : Rising edge of the phase A signal
- A \downarrow : Falling edge of the phase A signal
- B \uparrow : Rising edge of the phase B signal
- B \downarrow : Falling edge of the phase B signal

Rising edge: The point where the signal rises from a low level and passes through the specified signal level

Falling edge: The point where the signal falls from a high level and passes through the specified signal level

If the signal is that of an analog waveform, turn the logic sources off as shown earlier this manual in "Source Conditions," and then set the signal level that is counted as a pulse and the hysteresis. ► [See here.](#)

Timing2 (Timing2)

Select the edges that are counted as pulses when the multiplier is x2. The options are the same as were described above for Timing1.

When the multiplier is x2, if you select the same edges as in Timing1, the pulse count conditions are the same as were explained for multiplier x1.

Deceleration Prediction (Deceleration Prediction)

Set whether to compute the deceleration curve from the elapsed time after the pulse input stops.

- ON: Deceleration prediction is performed.
- OFF: Deceleration prediction is not performed.

► [See here.](#)

Stop Prediction (Stop Prediction)

Set the time from the point when the pulse input stops to the point when the instrument determines that the object has stopped.

- 2, 4, 8, 16: Stop prediction is performed on the basis of the specified number of times the pulse period (four settings) of the pulse one period before the pulse input stopped.
- OFF: Stop prediction is not performed.

► [See here.](#)

Logic Signal and Analog Waveform Conversion (DA)

Converts the logic signals that have been assigned to Source1 (the least significant digits) and Source2 (the most significant digits) into an analog waveform and scales the results

Math Source Waveforms (Source1 and Source2)

You can select the input channel of an installed logic module. Set the logic channel for the least significant digits to Source1 and the logic channel for the most significant digits to Source2.

You cannot select the input channels of a CAN Bus Monitor, CAN/CAN FD Monitor, CAN & LIN Bus Monitor, or SENT Monitor Module.

Type (Type)

Select the type of the logic signal.

- Unsigned: Unsigned integer
- Signed: Signed integer
- Offset Binary: Offset binary

Bit Length (Bit Length)

Set the bit length that will be converted to an analog signal. The length that you specify will be counted from the least significant bit.

Selectable range: 2 to 16. The default setting is 16.

Coefficient (K)

Set scaling coefficient K.

Selectable range: $-9.9999E+30$ to $+9.9999E+30$. The default setting is 1.0000.

Quartic Polynomial (Polynomial)

Performs a quartic polynomial calculation on the waveform that has been assigned to Source.

$$As^4 + Bs^3 + Cs^2 + Ds + E$$

A, B, C, and D: Scaling coefficients

s: Sampling data

E: Offset

Math Source Waveforms (Source)

The options are the same as were described for basic arithmetic with coefficients.

▶ [See here.](#)

Coefficients (A, B, C, D, and E)

Set the scaling coefficients (A, B, C, D) and the offset (E).

Selectable range: $-9.9999E+30$ to $+9.9999E+30$

Default values of A and B: 1.0000

Default values of C, D, and E: 0.0000

RMS Value (RMS)

Calculates the RMS value of the waveform that has been assigned to Source.

$$\sqrt{\frac{1}{N} \sum_{n=1}^N s(n)^2}$$

s: Sampling data

N: Number of samples

Math Source Waveforms (Source)

The options are the same as were described for basic arithmetic with coefficients. However, you cannot select input channels of frequency modules.

▶ [See here.](#)

Calculation Period (Calc Period)

Select the method that is used to determine the RMS calculation period.

- Edge: Rising, falling, or either edge of the selected signal
- Time: Specified time

If the Calculation Period Is Edge

- **Edge Detection Source (Edge Source)**

Select the input channel of the signal that is used to determine the calculation period.

If you want to use the same channel as the math source waveform, select Own. You can also select other channels.

▶ [See here.](#)

- **Level (Level), Slope (Slope), and Hysteresis (Hysteresis)**

Set the signal level,¹ the slope (rising or falling), and the hysteresis² of the edges that separate the calculation periods.

1 The signal level range is the same as the trigger level range. ▶ [See here.](#)

2 The hysteresis level is the same as the trigger hysteresis. ▶ [See here.](#)

If the Calculation Period Is Time

- **Time (Time)**

Set the calculation period time.

Selectable range: 1 ms to 500 ms. The default setting is 1 ms, and the resolution is 1 ms.

Effective Power (Power)

Calculates the effective power of the waveforms that have been assigned to Source1 and Source2

$$\frac{1}{T} \int_0^T (s1 \cdot s2) dt$$

T: 1 period (calculation period)

s1 and s2: Sampling data

dt: Sampling period

Math Source Waveforms (Source1, Source2)

Set the voltage and current input channels to use to calculate the effective power to Source1 and Source2.

The options are the same as were described for basic arithmetic with coefficients. However, you cannot select input channels of frequency modules.

▶ [See here.](#)

Calculation Period (Calc Period)

Set the calculation period for effective power.

Edge Detection Source (Edge Source)

Select the input channel of the signal that is used to determine the calculation period.

If you want to use the same channel as the math source waveform, select Source1 or Source2. You can also select other channels. ▶ [See here.](#)

Level (Level), Slope (Slope), and Hysteresis (Hysteresis)

Set the signal level, the slope, and the hysteresis of the edges that separate the calculation periods. These settings are shared with the [RMS](#) operation.

Effective Power Integration (Power Integ)

Integrates the effective power of the waveforms that have been assigned to Source1 and Source2.

$$\int_0^T (s1 \cdot s2) dt$$

T: Integration time

s1 and s2: Sampling data

dt: Sampling period

Math Source Waveforms (Source1, Source2)

Set the voltage and current input channels to use to integrate the effective power to Source1 and Source2.

The options are the same as were described for basic arithmetic with coefficients. However, you cannot select input channels of frequency modules.

▶ [See here.](#)

Reset Condition (Reset Condition)

Select the condition for resetting integration from one of the settings below.

- Start (Start): When the waveform acquisition starts
- Over limit (Overlimit): When the specified over-limit value is exceeded.
- Over limit value (OverlimitValue): Set the limit value when over limit is set to ON.
Selectable range: $-9.9999E+30$ to $+9.9999E+30$, in $1E-30$ steps

Manual Reset (Manual Reset)

To manually reset the integration, select Execute.

Scaling (Scaling)

Select the unit that is used on the vertical scale.

- Seconds (Second): The unit is seconds.
- Hours (Hour): The unit is hours.

Common Logarithm (Log1 and Log2)

- Log1: Calculates the common logarithm of the waveforms that have been assigned to Source1 and Source2 (the calculation is performed on "Source1/Source2").
 $K \cdot \text{Log}_{10}(s1/s2)$, where K: constant and s1, s2: sampling data
- Log2: Calculates the common logarithm of the waveform that has been assigned to Source.
 $K \cdot \text{Log}_{10}(s)$ where K: constant and s: sampling data

Math Source Waveforms (Source1, Source2, and Source)

The options are the same as were described for basic arithmetic with coefficients.

▶ [See here.](#)

Coefficient (K)

Set scaling coefficient K.

Selectable range: $-9.9999\text{E}+30$ to $+9.9999\text{E}+30$. The default setting is 1.0000.

Square Root (Sqrt1 and Sqrt2)

- Sqrt1: Calculates the square root of the sum (or difference) of the squares of the waveforms that have been assigned to Source1 and Source2. This can be used to analyze displacement and tolerance.

$$\sqrt{s1^2 \pm s2^2} \quad s1 \text{ and } s2: \text{ Sampling data}$$

- Sqrt2: Calculates the square root of the waveform that has been assigned to Source

$$\sqrt{s} \quad s: \text{ Sampling data}$$

Math Source Waveforms (Source1, Source2, and Source)

The options are the same as were described for basic arithmetic with coefficients.

▶ [See here.](#)

Sign (Sign)

Set the operator between $s1^2$ and $s2^2$ in Sqrt1.

- +: Addition
- -: Subtraction

Cosine (Cos) and Sine (Sin)

Uses the waveforms or logic signals that have been assigned to phases A, B, and Z to determine the angle, and then calculates the cosine or sine of this angle. You can use this to convert the angle to displacement.

Type (Type)

Select the type of the encoding. The settings other than the resolver channel (Resolver Ch) are shared with the [Rotary Angle](#) operation. You can select the resolver channel when a channel has been set for the resolver function of real time math.

- If there are multiple channels that have been defined with the resolver function, select the resolver channel setting, and then select the channel with Resolver Ch.
- If you specify a resolver channel, the setup menu explained later is not displayed.

Source Conditions (Source Condition)

Set the conditions of the source whose pulses you want to count. This setting is shared with the Rotary Angle operation.

▶ [See here.](#)

Pulses per Rotation (Pulse/Rotate), Bit Length (Bit Length)

Set the number of pulses per rotation. When the encode type is gray code, set the bit length. This setting is shared with the Rotary Angle operation.

Encoding Conditions (Encode Condition)

If the type of the encoding is ABZ, AZ, AB, or A, set the encoder's pulse multiplier and the timing (edge) for counting pulses. This setting is shared with the Rotary Angle operation.

Negative Logic ON/OFF (Negative logic)

Select negative or positive logic. This setting is shared with the Rotary Angle operation.

Manual Reset (Manual Reset)

To manually reset the computed value, select Execute.

Arc Tangent (Atan)

Calculates the arc tangent of the waveforms that have been assigned to Source1 and Source2 (the calculation is performed on "Source1/Source2"). You can use this to convert the displacement to an angle.

$\text{atan}(s1/s2)$ where $s1, s2$: sampling data

Math Source Waveforms (Source1 and Source2)

The options are the same as were described for basic arithmetic with coefficients.

▶ [See here.](#)

Scaling (Scaling)

Select the unit that is used on the vertical scale. This setting is shared with the [Rotary Angle](#) operation. However, there are no user-defined settings.

Quadrant Range (Quadrant)

Select the quadrant range to use for converting displacements to angles. This can be used on models with firmware version 2.05 and later.

- Quadrant-2: -90° to $+90^\circ$ ($-\pi/2$ to $+\pi/2$)
Even if a calculated result is between -180° and -90° or between $+90^\circ$ and $+180^\circ$, it is converted to an angle between -90° to $+90^\circ$.
- Quadrant-4: -180° to $+180^\circ$ ($-\pi$ to $+\pi$)

Electrical Angle (Electrical Angle)

Calculates the phase difference between (1) the angle that was determined from the logic signals that were specified for phases A, B, and Z, and (2) the fundamental wave component that was determined from the discrete Fourier transform of the waveform that was specified as the target. You can calculate the phase difference (electrical angle) between the motor's angle of rotation and the motor drive current.

Type (Type)

Select the type of encoding. The settings other than the resolver channel (Resolver Ch) are shared with the [Rotary Angle](#) operation. You can select the resolver channel when a channel has been set for the resolver function of real time math.

- If there are multiple channels that have been defined with the resolver function, select the resolver channel setting, and then select the channel with Resolver Ch.
- If you specify a resolver channel, set the scaling and the target on the setup menus explained later. Other setup menus do not appear.

Source Conditions (Source Condition)

Set the conditions of the source whose pulses you want to count. This setting is shared with the Rotary Angle operation. However, you can only specify the input channels of logic modules as math source waveforms.

▶ [See here.](#)

Pulses per Rotation (Pulse/Rotate), Bit Length (Bit Length)

Set the number of pulses per rotation. When the encode type is gray code, set the bit length. This setting is shared with the Rotary Angle operation.

Scaling (Scaling)

Select the unit that is used on the vertical scale. This setting is shared with the Rotary Angle operation. However, there are no user-defined settings.

Encoding Conditions (Encode Condition)

If the type of the encoding is ABZ, AZ, AB, or A, set the encoder's pulse multiplier and the timing (edge) for counting pulses. This setting is shared with the Rotary Angle operation.

Negative Logic ON/OFF (Negative logic)

Select negative or positive logic. This setting is shared with the Rotary Angle operation.

Target (Target)

The fundamental component of the waveform that you specify here is determined through a discrete Fourier transform. If the angle is the motor's angle of rotation and the target (Target) is the motor's drive current, the electrical angle can be determined.

The options are the same as were described for basic arithmetic with coefficients. However, you cannot select input channels of frequency modules.

▶ [See here.](#)

Knocking Filter (Knock Filter) (/VCE option)

When the signal level of the waveform that has been set to Source is less than or equal to the elimination level, the signal of this waveform is set to 0. You can select whether to perform differentiation. You can use this to extract knocking.

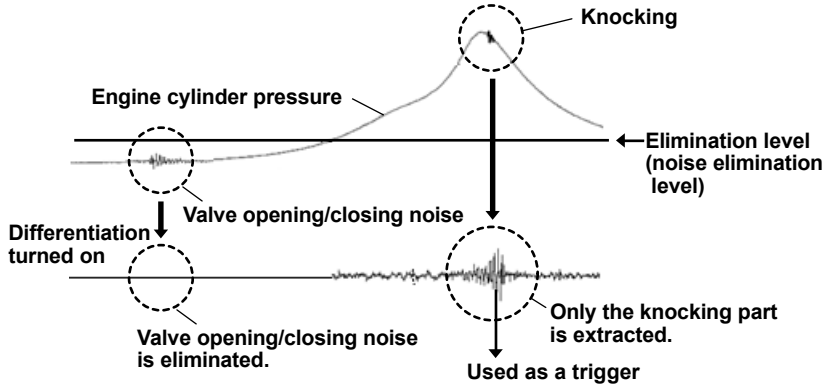

Math Source Waveforms (Source)

The options are the same as were described for basic arithmetic with coefficients. However, you cannot select the input channels of frequency modules or real time math channels (RTMath).

▶ [See here.](#)

Elimination Level

Set the elimination level, which is used to set the input signal to 0.

The range of the elimination level is the same as that of the trigger level. ▶ [See here.](#)

Differential

Select whether to differentiate the waveform after elimination. A fifth order Lagrange interpolation formula is used to perform differentiation. For details on the differentiation characteristics, see appendix 11.

- ON: Differentiation is performed.
- OFF: Differentiation is not performed.

Polynomial (Poly-Add-Sub)

Performs addition or subtraction or both on the waveforms that have been set to Source1, Source2, Source3, and Source4. You can add or subtract the result of the power calculation, to calculate the multi-phase power.

$K (\pm s1 \pm s2 \pm s3 \pm s4)$ where K: coefficients and s1, s2, s3, s4: sampling data

Math Source Waveforms (Source1, Source2, Source3, Source4)

The options are the same as were described for basic arithmetic with coefficients.

▶ [See here.](#)

Sign

You can set the sign of the sampling data of the math source waveforms to positive or negative.

Coefficient (K)

Set scaling coefficient K.

Selectable range: $-9.9999E+30$ to $+9.9999E+30$. The default setting is 1.0000.

Frequency (Frequency)

Calculates the frequency of the waveform that has been assigned to Source.

Math Source Waveforms (Source)

The options are the same as were described for basic arithmetic with coefficients. However, you can select an input channel of a logic module (select the channel, and then select the bit). You cannot select the input channel of a frequency module.

▶ [See here.](#)

Slope (Slope), Level (Level), Hysteresis (Hysteresis)

Set the signal level,¹ the slope (rising or falling), and the hysteresis² of the edges that are used to detect the periods. If the math source is the signal of a logic module, set only the slope.

1 The signal level range is the same as the trigger level range. ▶ [See here.](#)

2 The hysteresis level is the same as the trigger hysteresis. ▶ [See here.](#)

Scaling (Scaling)

Select the unit that is used on the vertical scale.

- Hz: The unit is hertz.
- Rpm: The unit is revolutions per minute.

Pulses per Rotation (Pulse/Rotate)

If scaling is set to Rpm, set the number of pulses per rotation.

Selectable range: 1 to 99999. The default setting is 1.

Deceleration Prediction (Deceleration Prediction)

Set whether to compute the deceleration curve from the elapsed time after the pulse input stops.

- ON: Deceleration prediction is performed.
- OFF: Deceleration prediction is not performed.

▶ [See here.](#)

Stop Prediction (Stop Prediction)

Set the time from the point when the pulse input stops to the point when the instrument determines that the object has stopped.

- 2, 4, 8, 16: Stop prediction is performed on the basis of the specified number of times the pulse period (four settings) of the pulse one period before the pulse input stopped.
- OFF: Stop prediction is not performed.

▶ [See here.](#)

Offset (Hz/Rpm) (Offset (Hz/Rpm))

Offset can be added to display only the changes in the frequency at a higher resolution.

Selectable range: $-9.9999E+30$ to $+9.9999E+30$. The default setting is 0.0000.

Period (Period)

Calculates the period of the waveform that has been assigned to Source.

Math Source Waveforms (Source)

The options are the same as were described for basic arithmetic with coefficients. However, you can select an input channel of a logic module (select the channel, and then select the bit). You cannot select the input channel of a frequency module.

▶ [See here.](#)

Slope (Slope), Level (Level), Hysteresis (Hysteresis), Deceleration Prediction (Deceleration Prediction), Stop Prediction (Stop Prediction)

Set the slope (rising or falling), the signal level, the hysteresis of the edges that are used to detect the periods, the deceleration prediction, and the stop prediction. These settings are shared with the [Frequency](#) operation.

Edge Count (Edge Count)

Counts the number of slope edges of the waveform that has been assigned to Source. You can use this to count the number of events in consecutive tests.

Math Source Waveforms (Source)

The options are the same as were described for basic arithmetic with coefficients. But, you can select the input channels of logic modules (select bits after selecting the input channels) and SENT S&C Error Trigger sub channels of SENT monitor modules. You cannot select the input channel of a frequency module.

▶ [See here.](#)

Slope (Slope), Level (Level), Hysteresis (Hysteresis)

Set the slope (rising or falling), the signal level, and the hysteresis of the edges that you want to count.

These settings are shared with the [Frequency](#) operation.

Reset Condition (Reset Condition)

Select the condition for resetting the count from one of the settings below.

- Start (Start): When the waveform acquisition starts
- Over limit (Overlimit): When the specified over-limit value is exceeded.
- Over limit value (OverlimitValue): Set the limit value when over limit is set to ON.
Selectable range: $-9.9999E+30$ to $+9.9999E+30$, in $1E-30$ steps

Manual Reset (Manual Reset)

To manually reset the count, select Execute.

Resolver (Resolver)

Calculates the angle of rotation from the sine signal and cosine signal that are generated from the detection coil of the resolver depending on the angle of the rotor.

Sine Phase Signal and Cosine Phase Signal (Sin Ch, Cos Ch)

Select the sine signal and the cosine signal that are generated from the detection coil of the resolver. The options are the same as were described for basic arithmetic with coefficients. However, you cannot select input channels of frequency modules.

▶ [See here.](#)

Excitation Signal(Carrier Ch)

Select the resolver's excitation signal. The options are the same as were described for basic arithmetic with coefficients. However, you cannot select input channels of frequency modules.

▶ [See here.](#)

Hysteresis (Hysteresis)

Set the rising edge hysteresis of the excitation, sine, and cosine signals. When the sample point mode in detail settings is set to Auto, this setting is applied to all signals. When the sample point mode is set to Manual, this setting is applied to the excitation signal.

Tracking Filter (Tracking Filter)

If the sine signal and cosine signal data is changing in a staircase pattern, select the cutoff frequency of the tracking filter that will smooth out the data that is used to calculate the angle of rotation.

OFF, 2 kHz, 1 kHz, 250 Hz, 100 Hz

Detail Setup (Detail)**Sample Point (Sample Point)**• **Mode (Mode)**

To enable more accurate calculations of the angle of rotation, set the mode that is used to sample the peak values of sine and cosine signals.

- Auto: The rising edges of the excitation, sine, and cosine signals are detected, and the peak values of sine signals and cosine signals are sampled automatically.
 - The Auto setting can be applied when the time difference of the sine and cosine signals in reference to the excitation signal is less than $\pm 90^\circ(\pi/2)$.
 - Turn the SCALE knob to set the vertical scale (V/div) so that the amplitudes of the excitation, and Sin and Cos signals are all ± 1.5 divisions or greater. If the amplitudes are less than ± 1.5 divisions, the Auto function will not operate.
- Manual: The rising edge of the excitation signal is detected, and sine and cosine signals at the specified time (Time) after this detected rising edge are sampled.

Time setting

Selectable range: 0.1 μs to 1000.0 μs . The default setting is 0.1 μs , and the resolution is 0.1 μs .

Scaling (Scaling)

Select how the upper and lower limits of the vertical scale are displayed.

-180° to $+180^\circ$, 0° to 360° , $-\pi$ to $+\pi$, 0 to 2π

Offset (°) (Offset(°))

An offset can be added to set the initial phase of the rotation angle.

Selectable range: -180.00° to $+180.00^\circ$. The default setting is 0.00° , and the resolution is 0.01° .



-
- To improve the calculation accuracy, set the vertical scale for each signal so that the signal amplitude is as large as possible.
 - Set the vertical scale to the same value for sine signals and cosine signals. If you specify different values, the instrument cannot perform calculations correctly.
-

Demodulation of the Pulse Width Modulated Signal (PWM)

Integrates a pulse width modulation signal and demodulates it to an analog signal.

Math Source Waveforms (Source)

The options are the same as were described for basic arithmetic with coefficients.

▶ [See here.](#)

Period of the Pulse Width Modulated Signal (Period)

Set the period of the pulse width modulated signal. The pulse width modulation signal is repeatedly integrated over the set period and demodulated to an analog signal.

Selectable range: 0.1 μs to 5000.0 μs . The default setting is 0.1 μs , and the resolution is 0.1 μs .

Torque (Torque)

This function measures frequency f of the waveform specified as the source* and calculates the torque. $A(f+c)$ where f : measurement frequency and A, C : coefficients

* This corresponds to the torque sensor that converts the torque value into frequency and outputs it.

Math Source Waveforms (Source)

The options are the same as were described for basic arithmetic with coefficients. However, you can select the input channels of logic modules (select the channel, and then select the bit). You cannot select the input channel of a frequency module.

▶ [See here.](#)

Slope (Slope), Level (Level), Hysteresis (Hysteresis)

Set the signal level,¹ the slope (rising or falling), and the hysteresis² of the edges that are used to detect the periods. If the math source is the signal of a logic module, set only the slope.

- 1 The signal level range is the same as the trigger level range. ▶ [See here.](#)
- 2 The hysteresis level is the same as the trigger hysteresis. ▶ [See here.](#)

Deceleration Prediction (Deceleration Prediction)

Set whether to compute the deceleration curve from the elapsed time after the pulse input stops.

- ON: Deceleration prediction is performed.
- OFF: Deceleration prediction is not performed.

▶ [See here.](#)

Stop Prediction (Stop Prediction)

Set the time from the point when the pulse input stops to the point when the instrument determines that the object has stopped.

- 2, 4, 8, 16: Stop prediction is performed on the basis of the specified number of times the pulse period (four settings) of the pulse one period before the pulse input stopped.
- OFF: Stop prediction is not performed.

▶ [See here.](#)

Coefficients (A and C)

Set the scaling coefficient (A) and the frequency reference (C).

3 Phase Resolver (3 Phase Resolver)

Calculates the angle of rotation from the two sine signals that are generated from the detection coil of the 3 phase resolver depending on the angle of the rotor.

Sine Signal Phase (Phase)

Select the phases of the two sine signals that are generated from the detection coil of the 3 phase resolver. 0° to 120°, 0° to 240°, 120° to 240°

Sine Signal (Sin Ch)

In accordance with the phases selected in the previous section, select the sine signals that are generated from the detection coil of the 3 phase resolver. The options are the same as were described for basic arithmetic with coefficients. However, you cannot select input channels of frequency modules. ► [See here.](#)

Excitation Signal(Carrier Ch)

Select the 3 phase resolver's excitation signal. The options are the same as were described for basic arithmetic with coefficients. However, you cannot select input channels of frequency modules. ► [See here.](#)

Hysteresis (Hysteresis)

Set the rising edge hysteresis of the excitation, and sine signals. When the sample point mode in detail settings is set to Auto, this setting is applied to all signals. When the sample point mode is set to Manual, this setting is applied to the excitation signal.

Tracking Filter (Tracking Filter)

If the sine signal and cosine signal data is changing in a staircase pattern, select the cutoff frequency of the tracking filter that will smooth out the data that is used to calculate the angle of rotation.

OFF, 2 kHz, 1 kHz, 250 Hz, 100 Hz

Detail Setup (Detail)

Sample Point (Sample Point)

- **Mode (Mode)**

To enable more accurate calculations of the angle of rotation, set the mode that is used to sample the peak values of sine signals.

- Auto: The rising edges of the excitation and sine signals are detected, and the peak values of sine signals are sampled automatically.
 - The Auto setting can be applied when the time difference of the sine signals in reference to the excitation signal is less than $\pm 90^\circ$ ($\pi/2$).
 - Turn the SCALE knob to set the vertical scale (V/div) so that the amplitudes of the excitation, and sine signals are all ± 1.5 divisions or greater. If the amplitudes are less than ± 1.5 divisions, the Auto function will not operate.
- Manual: The rising edge of the excitation signal is detected, and sine signals at the specified time (Time) after this detected rising edge are sampled.

Time setting

Selectable range: 0.1 μ s to 1000.0 μ s. The default setting is 0.1 μ s, and the resolution is 0.1 μ s.

Scaling (Scaling)

Select how the upper and lower limits of the vertical scale are displayed.

-180° to $+180^\circ$, 0° to 360° , $-\pi$ to $+\pi$, 0 to 2π

Offset (°) (Offset(°))

An offset can be added to set the initial phase of the rotation angle.

Selectable range: -180.00° to $+180.00^\circ$. The default setting is 0.00° , and the resolution is 0.01° .



- To improve the calculation accuracy, set the vertical scale for each signal so that the signal amplitude is as large as possible.
- Set the vertical scale to the same value for sine signals and cosine signals. If you specify different values, the instrument cannot perform calculations correctly.

Notes Regarding Using the Digital Filter and Real Time Math

Real Time Math Source Modules and Channels

The modules and channels that you can select as real time math source waveforms (source) are shown below.

	Input Module Model or Real Time Math Channel (RTMath)					
	(Yes: Can be selected, No: Cannot be selected)					
Operators and Functions	720256, 701250, 720250, 701251, 701255, 720268, 701261, 701262, 701265, 720266, 701270, 701271, 701275, 720212, 720211, 720221 ¹ , 720254	701281 720281	720230	720240 ^{1, 2} 720241 ^{1, 2} 720242 ^{1, 2} 720243 ^{1, 2} (available only with the /VCE option)	RTmath ³	
A(S1)+B(S2)+C, A(S1)-B(S2)+C, A(S1)*B(S2)+C, A(S1)/B(S2)+C	Yes	Yes	No	Yes	Yes	
Diff(S1), Integ1(S1), Integ2(S1)	Yes	Yes	No	Yes	Yes	
Rotary Angle	Yes ⁴	No	Yes ⁴	Yes	No	
Rotary Speed	Yes ⁴	No	Yes ⁴	Yes	No	
DA	No	No	Yes	No	No	
Polynomial	Yes	Yes	No	Yes	Yes	
RMS, Power	Waveform to be computed	Yes	No	No	Yes	Yes
	Edge source	Yes	No	Yes	Yes ²	Yes
Power Integ	Yes	No	No	Yes	Yes	
Log1, Log2	Yes	Yes	No	Yes	Yes	
Sqrt1, Sqrt2	Yes	Yes	No	Yes	Yes	
Cos, Sin	Yes ⁴	No	Yes ⁴	Yes	No	
Atan	Yes	Yes	No	Yes	Yes	
Electrical Angle	Waveform to be computed	No	No	Yes	No	No
	Target	Yes	No	No	Yes	Yes
Knock Filter (available only with the /VCE option)	Yes	No	No	Yes	No	
Poly-Add-Sub	Yes	Yes	No	Yes	Yes	
Frequency, Period	Yes	No	Yes	Yes	Yes	
Edge Count	Yes	No	Yes	Yes ²	Yes	
Resolver	Yes	No	No	Yes	Yes	
PWM	Yes	Yes	No	Yes	Yes	
Torque	Yes ⁵	No	Yes	Yes	Yes	
3 Phase Resolver	Yes	No	No	Yes	Yes	

For the names of the input modules, see the *Getting Started Guide*, IM DL950-03EN.

- 1 To set the input channels of a 720221 16-CH temperature/voltage input module as the source waveforms of real time math, you have to set the input coupling (Coupling) to DC, TC, or GND. To set the input channels of a 720240 CAN bus monitor module, 720242 CAN/CAN FD monitor, 720241 CAN & LIN bus monitor module, or 720243 SENT monitor module as the source waveforms of real time math, you have to turn on the input (Input) of the target sub channel.
- 2 Input channels of a 720240 CAN bus monitor, 720242 CAN/CAN FD monitor, or 720241 CAN & LIN bus monitor module cannot be selected if the data type (Value Type) is set to Logic. Even if the data type is not set to Logic, you cannot use data that exceeds 16 bits in length. On a 720243 SENT monitor module, S&C and Error Trigger sub channels cannot be selected. However, if the function is Edge Count, these channels can be selected.
- 3 If you set the real time math channel to RTmathX, you can select the RTmath waveforms on channels up to RTmathX1. If the real time math channel is RTmath1, you cannot select another real time math channel.
- 4 If you have turned logic sources on, select an input channel of a 720230 logic module. If logic sources have been turned off, select an input channel of an analog waveform module.
- 5 You cannot select the input channels of a 720221 16-CH temperature/voltage input module.

Math Delay

The real time math delay is “1.4 μ s + the digital filter delay + the math delay.”

The digital filter and math delays vary depending on the type of filter and math operation.

- If you are using the result of a real time math channel as the source waveform for another real time math operation, the math delays accumulate.
- For details, see appendix 11.

Internal Processing of Real Time Math

The math source waveforms are 16-bit binary data. If they are only 12 or 14 bits long, they are converted to 16 bits. Internally, the waveforms are converted to floating-point numbers and calculated.

- The computer results are stored in 32-bit floating point format to the acquisition memory.
- The data stored in the acquisition memory is converted into 16-bit data in relation to the display range (Value/Div) and displayed. You can change the display range values even after data acquisition.
- For details on the internal computing format, see appendix 11.

Differences between Real Time Math and Standard Math

This section explains the differences between the real time math operations (/G03, /G05 option) and power math operations (/G05 option) that you configure by pressing RT.MATH CH and the standard math operations that you configure by pressing MATH.

Real Time Math

- Math operations can be performed in real time on waveforms (A/D converted data) that are applied to the input channels of each of the modules.
- Even when the display is in roll mode, you can view the real time math results.
- There are no limits on the record length. However, the record length that you can specify per channel is reduced when real time math is used because data is acquired in a different acquisition memory area than the area for normal input channels.
- You can trigger the instrument on real time math results.
- Regardless of the instrument’s sample rate, math operations are always performed on the data that is output from each module at a maximum math rate of 10 MS/s.
- Real time math can be used in all acquisition modes (including the dual capture mode).

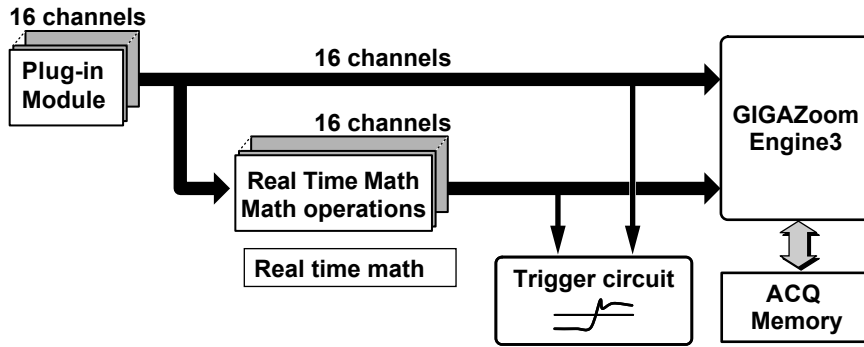

Standard Math

- Because waveforms are processed after they are acquired, the waveform update period is long.
- Math cannot be performed when the display is in roll mode.
- Math is performed on data that was acquired into acquisition memory at the instrument sample rate.
- Because math results are stored in the main memory of the main CPU, there are limits on the record length (for one channel, the maximum is 1 Mpoint).
- You can not trigger the instrument on math results.
- Because math is performed by a general-purpose CPU, a wide variety of expressions are available.

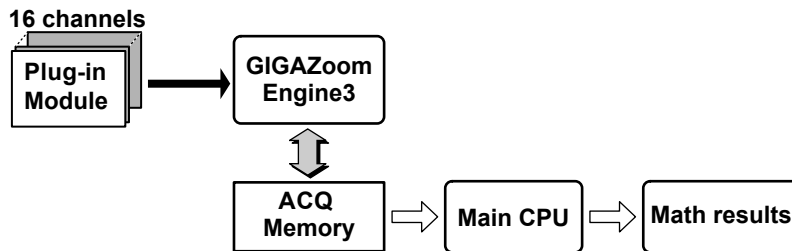

17 Power Math (/G05 option)

The following analysis can be performed.

- [Power Analysis \(Power\)](#)
- [Harmonic Analysis \(Harmonics\)](#)

Numeric Monitor Mode (Digital Monitor Mode)

▶ [See here.](#)

Power Analysis (Power)

The voltage and current measured on separate input channels can be used as math sources to calculate various power parameters for power analysis. This is a feature available on the /G05 option.

- Power analysis can be performed only when one of the following modules is installed in this instrument. 720256 (4CH10M16), 701250 (HS10M12), 720250 (HS10M12), 701251 (HS1M16), 701255 (NONISO_10M12), 720268 (HV (AAF, RMS)), 720212 (HS200M14), 720211 (HS100M12), 701261 (UNIVERSAL), 701262 (UNIVERSAL (AAF)), 701265 (TEMP/HPV), 720266 (TEMP/HPV), 701275 (ACCL/VOLT), 720254 (4CH 1M16)
- Power analysis results are output to the sub channels of RTmath13 and RTmath14. The number of calculations performed in one analysis is equal to the total number of sub channels of RTmath13 and RTmath14.
- Power analysis can be performed on two systems. This allows power efficiency and motor efficiency to be calculated.
- The maximum number of power analysis parameters that can be calculated is 118 when one system is measured and 58 each when two systems are measured. The number of parameters varies depending on the number of systems to be analyzed and wiring system. For details, see the appendix.
- Power analysis conditions can be changed even during waveform acquisition. However, if you change the conditions, the measurement count (waveform acquisition count) is reset. The measurement count is displayed in the lower left of the screen.
- The analysis result waveform can be used as a trigger source, but it cannot be used as a real time math source.

Measurement Function

The various physical quantities such as rms voltage, average current, power, and phase difference that the instrument measures and displays are called measurement functions. Each physical quantity is displayed with a corresponding symbol.

For example, Urms represents the true rms voltage.

Source Channels

The channels that receive the pair of voltage and current signals to be measured are called source channels. There are three source channel numbers: 1, 2, and 3. The instrument displays a source channel number after the measurement function symbol to indicate which source channel corresponds to the displayed numeric data.

For example, Urms1 represents the true rms voltage of source channel 1.

The channels that can be used as source channels are those of the modules that can perform power analysis (indicated above).

Wiring Unit

Wiring Unit refers to a group of two or three input source channels with the same wiring system used to measure three-phase power.

Wiring unit is represented with the symbol Σ . Measurement functions for wiring units are called Σ functions.

For example, Urms Σ represents the true rms value of the average of the voltages measured on the input source channels assigned to wiring unit Σ .

• Configuration Example of Wiring System and Wiring Unit

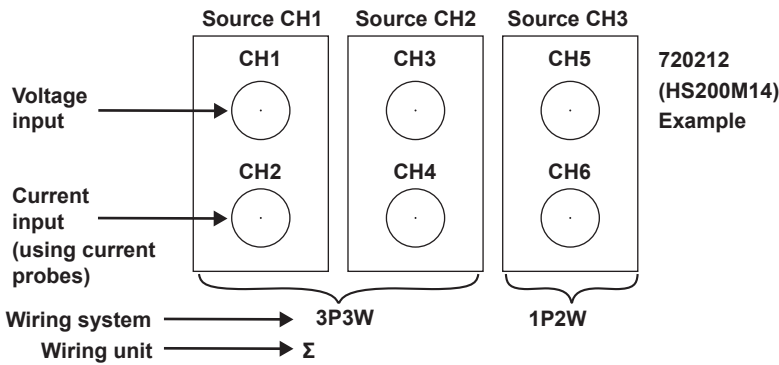

Delta Math

Measurement function ΔU and ΔI can be determined based on the sum and difference of the instantaneous voltage and current (sampling data) of the source channels assigned to the wiring unit set as the delta math source. This calculation is called *delta math*.

3P4W→3V3A

- Using the data of a three-phase four-wire system, delta connection data can be calculated from star connection data (star-delta transformation).

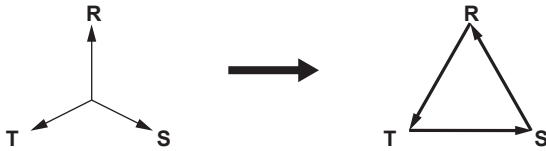

3V3A→3P4W

- Using the data of a three-phase three-wire system (three-voltage three-current method), star connection data can be calculated from delta connection data (delta-star transformation). This is useful when you want to observe the phase voltage of a measurement source without a neutral line.

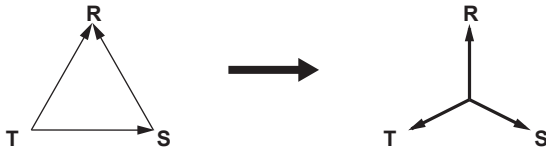

Measurement Function Types

- Source channel measurement functions

The following 32 measurement functions are available.

U (voltage): Urms (rms value),¹ Umn (rectified mean value calibrated to the rms value),¹ Udc (simple average), Uac (AC component)

I (current): Irms (rms value),¹ Imn (rectified mean value calibrated to the rms value),¹ Idc (simple average), Iac (AC component)

P (active power), S (apparent power), Q (reactive power), λ (power factor), φ (phase difference), fU (voltage frequency),

fI (current frequency), U+pk (maximum voltage), U-pk (minimum voltage), I+pk (maximum current), I-pk (minimum current), P+pk (maximum power), P-pk (minimum power), WP (integrated power), WP+ (positive integrated power),

WP- (negative integrated power)

q (integrated ampere-hour), q+ (positive integrated ampere-hour), q- (negative integrated ampere-hour), WS (volt-ampere hours), WQ (var hours),

Z (impedance), RS (series resistance),² XS (series reactance),² RP (parallel resistance),² XP (parallel reactance)²

1 You can select either the rms value or the rectified mean value calibrated to the rms value (but not both). In either case, the value is displayed as rms.

2 You can select series resistance or parallel resistance (but not both). You can select series reactance or parallel reactance (but not both).

- **Wiring unit Σ measurement functions**

The following 24 measurement functions are available.

U Σ (average voltage): Urms Σ (rms value),¹ Umn Σ (rectified mean value calibrated to the rms value),¹ Udc Σ (simple average), Uac Σ (AC component)

I Σ (average current): Irms Σ (rms value),¹ Imn Σ (rectified mean value calibrated to the rms value),¹ Idc Σ (simple average), Iac Σ (AC component)

P Σ (total active power), S Σ (total apparent power), Q Σ (total reactive power), $\lambda\Sigma$ (average power factor), $\phi\Sigma$ (average phase difference)

WP (total integrated power), WP+ Σ (total positive integrated power), WP- Σ (total negative integrated power), q Σ (total integrated ampere-hour), q+ Σ (positive total integrated ampere-hour), q- Σ (negative total integrated ampere-hour),

WS Σ (total apparent energy), WQ Σ (total reactive energy), Z Σ (average impedance), RS Σ (average series resistance),² XS Σ (average series reactance),² RP Σ (average parallel resistance),² XP Σ (average parallel reactance)²

- 1 You can select either the rms value or the rectified mean value calibrated to the rms value (but not both). In either case, the value is displayed as rms.
- 2 You can select average series resistance or average parallel resistance (but not both). You can select average series reactance or average parallel reactance (but not both).

- **Delta Computation Functions**

For details on line voltages and R, S, and T points, see the [wiring system](#) figure provided later.

3P3W→3V3A

The following 8 measurement functions are available.

Urs (R-S voltage): Urms3 (rms value),* Umn3 (rectified mean value calibrated to the rms value),* Udc3 (simple average), Uac3 (AC component)

It (phase current): Irms3 (rms value),* Imn3 (rectified mean value calibrated to the rms value),* Idc3 (simple average), Iac3 (AC component)

3V3A→3P4W

The following 13 measurement functions are available.

Ur (R-N voltage): Urms1 (rms value),* Umn1 (rectified mean value calibrated to the rms value),* Udc1 (simple average), Uac1 (AC component)

Us (S-N voltage): Urms2 (rms value),* Umn2 (rectified mean value calibrated to the rms value),* Udc2 (simple average), Uac2 (AC component)

Ut (T-N line voltage): Urms3 (rms value),* Umn3 (rectified mean value calibrated to the rms value),* Udc3 (simple average), Uac3 (AC component)

In (neutral line current)

3P4W→3V3A

The following 13 measurement functions are available.

Urs (R-S voltage): Urms1 (rms value),* Umn1 (rectified mean value calibrated to the rms value),* Udc1 (simple average), Uac1 (AC component)

Ust (S-T voltage): Urms2 (rms value),* Umn2 (rectified mean value calibrated to the rms value),* Udc2 (simple average), Uac2 (AC component)

Utr (T-R line voltage): Urms3 (rms value),* Umn3 (rectified mean value calibrated to the rms value),* Udc3 (simple average), Uac3 (AC component)

In (neutral line current)

- * You can select either the rms value or the rectified mean value calibrated to the rms value (but not both). In either case, the value is displayed as rms.

- **Other measurement functions**

The following 3 measurement functions are available.

η (efficiency): Motor efficiency, power efficiency

Uubf (three-phase voltage unbalance factor)

Iubf (three-phase current unbalance factor)

Analysis Mode (Analysis Mode)

Select the system to be analyzed.

- 1 Wiring System: One system is analyzed.
- 2 Wiring Systems: Two systems are analyzed. The primary and secondary sides of the system to be analyzed can be measured to derive the efficiency.
- OFF: Power analysis is disabled.
- **Device's power factor example**

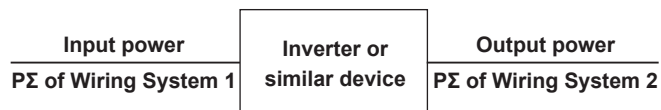

Setting Analysis Conditions (Wiring System)

Set the following items.

- [Wiring System \(Wiring\)](#)
- [Math Source Waveforms \(U1 to U3, I1 to I3\)](#)
- [Detailed Analysis Setting \(Detail\)](#)
 - [Calculation Period](#)
 - [Analysis settings](#)
 - [Efficiency settings](#)
- [Power Analysis Items \(Power Analysis Item\)](#)

Integration Reset

Resets power integration and time integration.

- Reset Wiring System 1 (Reset Wiring System 1)^{1,2}
- Reset Wiring System 2 (Reset Wiring System 2)²
- Reset Wiring System 1&2 (Reset Wiring System 1&2)²
 - 1 Available when analysis mode is 1 Wiring System.
 - 2 Available when analysis mode is 2 Wiring System.

Wiring System (Wiring)

The following eight wiring systems are available on the instrument.

1P2W: Single-phase two-wire system

1P3W: Single-phase three-wire

3P3W: Three-phase three-wire

3V3A: Three-voltage three-current measurement method

3P4W: Three-phase four-wire

3P3W→3V3A: Conversion of three-phase three-wire system data to the three-voltage three-current measurement method

3V3A→3P4W: Delta-star transformation using three-phase three-wire system data

3P4W→3V3A: Star-delta transformation using three-phase four-wire system data

To apply voltage, use a passive probe.

For details on how to select the appropriate passive probes and how to connect them (high and low), see section 3.6 in the *Getting Started Guide*, IM DL950-03EN.

To apply current, use a current probe.

For details on how to select the appropriate current probes and how to connect them (current direction), see section 3.6 in the *Getting Started Guide*, IM DL950-03EN, and the user's manual that came with the current probe.

- **Single-Phase Two-wire (1P2W)**

Two channels that receive one pair of voltage and current signals can be wired.

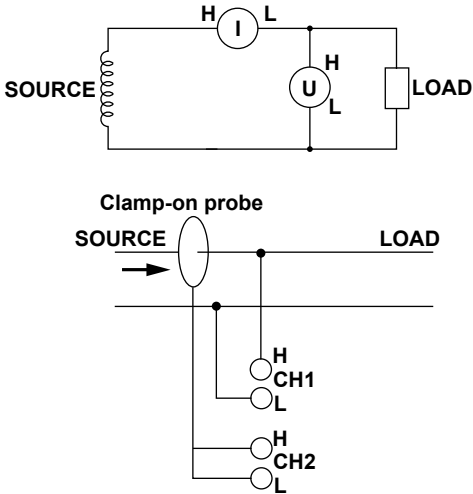

- **Single-Phase Three-Wire (1P3W)**

Four channels that receive two pairs of voltage and current signals can be wired.

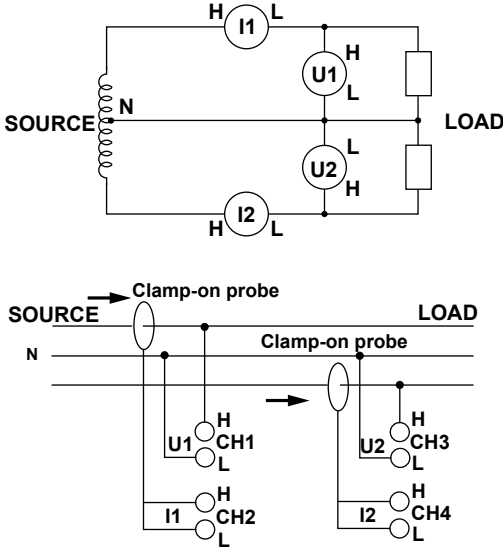

- **Three-Phase Three-Wire (3P3W)**

Four channels that receive two pairs of voltage and current signals can be wired.

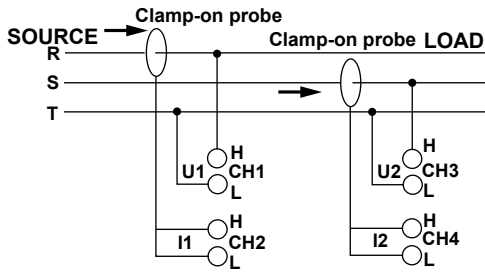
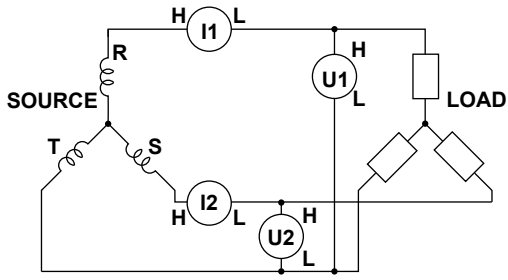

- **Three-Voltage Three-Current Method (3V3A)**

Six channels that receive three pairs of voltage and current signals can be wired.

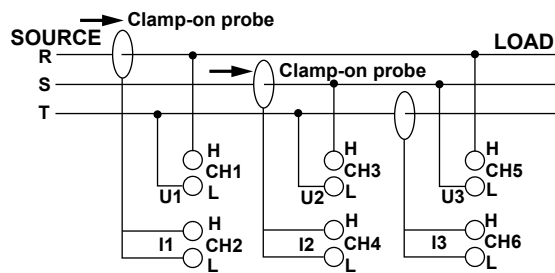
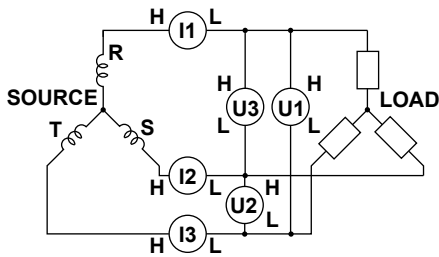

• **Three-Phase Four-Wire (3P4W)**

Six channels that receive three pairs of voltage and current signals can be wired.

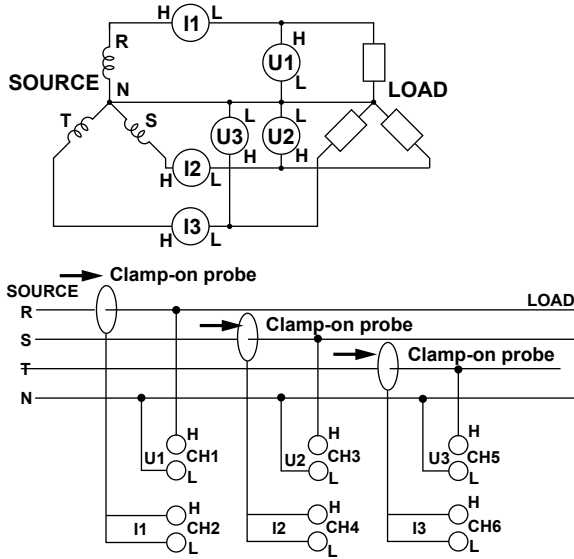

• **Conversion of Three-Phase Three-Wire System Data to the Three-Voltage Three-Current Measurement Method (3P3W→3V3A)**

Four channels that receive two pairs of voltage and current signals can be wired. U_{rs} and I_t can be determined using delta math.

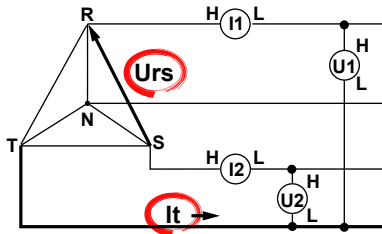

• **Delta-Star Transformation (3V3A→3P4W)**

Six channels that receive three pairs of voltage and current signals can be wired. U_r , U_s , U_t , and I_n can be determined using delta math. The center of the delta connection is assumed to be the center of the star connection. If the actual centers are not aligned, errors will result in the calculation.

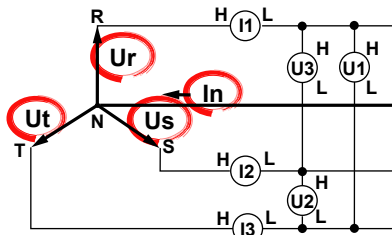

• **Star-Delta Transformation (3P4W→3V3A)**

Six channels that receive three pairs of voltage and current signals can be wired. U_{rs} , U_{st} , U_{tr} , and I_n can be determined using delta math.

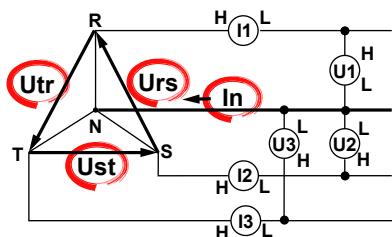

Math Source Waveforms (U1 to U3, I1 to I3)

Set math source waveforms. For modules that can perform power analysis, see [“Power Analysis \(Power\).”](#)

Detailed Analysis Setting (Detail)

Calculation Period (Calc Period)

Type (Type)

Select the method that is used to determine the calculation period of power math values.

- **Edge:** Power math starts when an edge is detected on the specified channel. When the next edge is detected, the power between edges is computed.
- **Timer:** Calculation is performed at the specified interval, regardless of edge detection.
- **Transient (Transient):** This is used for analyzing transient states from the stopped state of power and other measurements at motor startup. The mode automatically switches to Timer (calculation at a given interval) when a stop is detected when no edges have been detected. Calculation starts on either edge when an edge is detected the first time, regardless of the edge detection setting.

If the Calculation Period Is Edge

• Edge Detection Source (Edge Source)

Select the input channel of the signal that is used to determine the calculation period.

• Hysteresis (Hysteresis)

The same as the standard feature. For details, see [“Trigger Hysteresis”](#) in chapter 4.

• Edge Source Filter (Edge Source Filter)

Select from the following.

OFF, 128 kHz, 64 kHz, 32 kHz, 16 kHz, 8 kHz, 4 kHz, 2 kHz, 1 kHz, 500 Hz, 250 Hz, 125 Hz, 62.5 Hz

The instrument reduces the effects of noise by using hysteresis when it detects zero crossings.

If the synchronization source is distorted or harmonics and noise are superposed on the signal to a level exceeding this hysteresis, harmonic components will cause zero crossing detection to occur frequently, and the zero crossing of the fundamental frequency will not be detected stably. Consequently, the measured voltage and current may be unstable. To stably detect zero crossings, set the edge source filter.

When the Calculation Period Is Timer

Set the calculation period update time.

Selectable range: 100 ns to 500 ms. Resolution: 100 ns.

When the Calculation Period Is Transient

• Edge Detection Source (Edge Source)

The options are the same as Edge.

• Hysteresis (Hysteresis) and Edge Source Filter (Edge Source Filter)

The options are the same as Edge.

• Stop Prediction (Stop Prediction)

Set the time from the point when the pulse input stops to the point when the instrument determines that the object has stopped.

- 2, 4, 8, 16: Stop prediction is performed on the basis of the specified number of times the pulse period (four settings) of the pulse one period before the pulse input stopped.

For details, see [“FV Settings \(FV Setup\)”](#) in chapter 2.

• 0 Output after Stop Prediction (0 Output after Stop Prediction)

Set whether to reset the computed value to zero when the stop prediction feature determines that a stop state has occurred.

OFF: The computed value is not reset to zero.

ON: The computed value is reset to zero.

- **Update Time (Auto Timer)**

Automatically starts the math timer when in a stopped state.
 Selectable range: 100 ns to 500 ms. Resolution: 100 ns.

Analysis Setting (Analysis Setting)

Set how to calculate power math values.

- **RMS Type (RMS Type)**

Select the rms value from the following.

True RMS (rms value), Rect.Mean (rectified mean value calibrated to the rms value)

- **ϕ Scaling (ϕ Scale)**

Select how to display phase differences.

Radian: Radian

Degree: Degrees

- **Load Circuit Connection Type (Load circuit connection type)**

Select the load circuit connection type from the following.

Series: Series is selected.

Parallel: Parallel is selected.

- **Integration Setup (Integration Setup)**

- Integration Condition (Condition)

All Times (All Times): Integration is performed at all times.

In Acquisition (In Acquisition): Integration is performed only during measurement.

- Reset on Start (Reset on Start)

OFF: Integration continues regardless of the START/STOP key state. To reset the value, reset manually.

ON: The integrated value is reset to zero whenever waveform acquisition starts as a result of pressing the START/STOP key.

When integration condition is set to All Times

- When Reset on Start is OFF

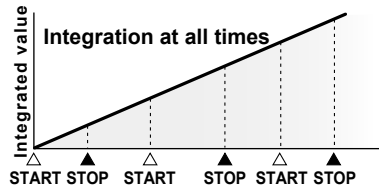

- When Reset on Start is ON

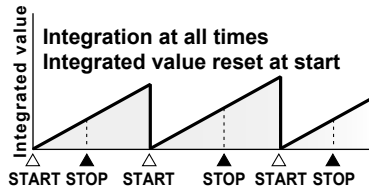

When integration condition is set to In Acquisition

- When Reset on Start is OFF

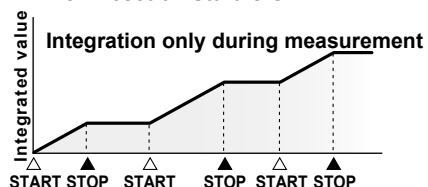

- When Reset on Start is ON

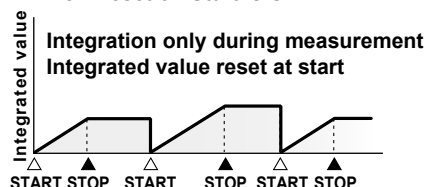

- Scaling (Scaling)

Select the unit time of integration time from the following.

Second (Second), Hour (Hour)

Efficiency Setting (Efficiency Setting)

Select the measurement function efficiency η type from the following.

- Power: The power efficiency is calculated. Available when the analysis mode is 2Wiring Systems.
- Motor: The motor drive efficiency is calculated.
- OFF: Efficiency is not calculated.

- **Pm Type (Pm Type)**

Select the type of rotating speed.

RotationAngle: Rotation angle (rad/s)

Speed: Rotating speed

When the Pm Type Is RotationAngle

- **Rotation Angle (Rotation Angle)**

Select the real time math channel set to math "Rotary Angle."

When the Pm Type Is Speed

- **Speed**

Select the input channel of the module measuring the number of rotations.

- **Scaling (Scaling)**

Select the unit that is used on the vertical scale.

rps: The unit is set to revolutions per second.

rpm: The unit is set to revolutions per minute.

- **Coefficient (K)**

Set scaling coefficient K.

Selectable range: $-9.9999E + 30$ to $+9.9999E + 30$. The default setting is 1.0000.

- **Torque (Torque)**

Select the real time math channel set to math "Torque."

Power Analysis Items (Power Analysis Item)

Power Analysis Items (Power Analysis Item)

Power analysis results are output to RTmath13 and RTmath14. Select the check boxes for the measurement functions you want to output.

- All ON (All ON): The check boxes of all items are selected.
- All OFF (All OFF): The check boxes of all items are cleared.
- Default (default): The check boxes of only the default settings are selected. This is available when analysis mode is 1 Wiring System.

All Items Output Setup (All Items Output Setup)

- Waveform color: Select the waveform color.
- Label (Label): Set the label using up to 16 characters.
- Upper/Lower (Upper/Lower): $-9.9999E+30$ to $+9.9999E+30$ in 1E-30 steps

Harmonic Analysis (Harmonics)

Harmonics refer to sine waves whose frequency is an integer multiple (2 and higher) of the fundamental wave except for the fundamental wave itself.

When the fundamental is mixed with harmonics, waveform distortion results.

The instrument analyzes the harmonics of rms values (voltage and current) and active power.

The instrument analyzes harmonic orders 1 to 40 for rms values and 1 to 35 for active power.

This is a feature available on the /G05 option.

- Harmonic analysis can be performed only when one of the following modules is installed in this instrument. 720256 (4CH10M16), 701250 (HS10M12), 720250 (HS10M12), 701251 (HS1M16), 701255 (NONISO_10M12), 720268 (HV (AAF, RMS)), 720212 (HS200M14), 720211 (HS100M12), 701261 (UNIVERSAL), 701262 (UNIVERSAL (AAF)), 701265 (TEMP/HPV), 720266 (TEMP/HPV), 701275 (ACCL/VOLT), 720254 (4CH 1M16)
- Harmonic analysis results are output to the sub channels of RTmath15 and RTmath16. The number of calculations performed in one analysis is equal to the total number of sub channels of RTmath15 and RTmath16.
- The maximum number of harmonic analysis parameters that can be calculated is as follows.
Harmonic analysis of rms values: 123 parameters
Harmonic analysis of active power: 121 parameters
- The harmonic analysis result waveform can be used as a trigger source, but it cannot be used as a real time math source.

Measurement Functions and Source Channels

For the terminology definitions, see "[Measurement Functions](#)" and "[Source Channels](#)" provided in the Power Analysis section.

Measurement Function Types

The following measurement functions are available.

- **Rms Value Measurement Functions**

RMS (rms values of the 1st to the 40th harmonic), Rhdf (percentage contents of the 1st to the 40th harmonic), ϕ (phases of the 1st to the 40th harmonic), RMS (total rms value), THDIEC (distortion factor: IEC), THDCSA (distortion factor: CSA)

- **Active Power Measurement Functions**

P (active powers of the 1st to the 35th harmonic), Phdf (active power percentage contents of the 1st to the 35th harmonic), ϕ (active power phases of the 1st to the 35th harmonic), P (all active powers), S (all apparent powers), Q (all reactive powers), λ (power factor), U1 (1st harmonic rms voltage), U2 (1st harmonic rms voltage), U3 (1st harmonic rms voltage), I1 (1st harmonic rms current), I2 (1st harmonic rms current), I3 (1st harmonic rms current), ϕ U1-U1 (phase angle), ϕ U1-I1 (phase angle), ϕ U1-U2 (phase angle), ϕ U1-I2 (phase angle), ϕ U1-U3 (phase angle), ϕ U1-I3 (phase angle)

Analysis Mode (Analysis Mode)

Select the harmonic analysis item.

- Line RMS: Harmonic analysis is performed on voltage and current.
- Power: Harmonic analysis is performed on active power.
- OFF: Harmonic analysis is disabled.

Setting Analysis Conditions (Wiring System)

Set the following items.

When the Analysis Mode Is Line RMS

- [Math Source Waveform \(Source\)](#)
- [Calculation Period \(Calc Period\)](#)
- [\$\phi\$ Scaling \(\$\phi\$ Scale\)](#)
- [Harmonic Analysis Items \(Power Analysis Item\)](#)

When the Analysis Mode is Power

- [Wiring System \(Wiring\)](#)
The same as Wiring System under “Power Analysis (Power).”
- [Math Source Waveforms \(U1 to U3, I1 to I3\)](#)
The options are the same as the [math source waveforms](#) when the analysis mode is Line RMS.
- [Analysis Details \(Detail\)](#)
 - [Calculation Period \(Calc Period\)](#)
 - [\$\phi\$ Scaling \(\$\phi\$ Scale\)](#)
- [Harmonic Analysis Items \(Power Analysis Item\)](#)

Math Source Waveform (Source)

Set math source waveforms. For modules that can perform harmonic analysis, see “[Harmonic Analysis \(Harmonic\)](#).”

Calculation Period (Calc Period)

- [Edge Detection Source \(Edge Source\)](#)

When the Analysis Mode Is Line RMS

The same channel as the math source waveform (cannot be changed).

When the Analysis Mode is Power

The same channel as the math source waveform. Select from U1 to U3 and I1 to I3.

- [Hysteresis \(Hysteresis\)](#)
The same as the standard feature. For details, see “[Trigger Hysteresis](#)” in chapter 4.
- [Edge Source Filter \(Edge Source Filter\)](#)
Select from the following.
OFF, 128 kHz, 64 kHz, 32 kHz, 16 kHz, 8 kHz, 4 kHz, 2 kHz, 1 kHz, 500 Hz, 250 Hz, 125 Hz, 62.5 Hz
This is the same as “[Edge Source Filter](#)” described under “Power Analysis (Power).”

ϕ Scaling (ϕ Scale)

Select how to display phase differences.

- Radian: Radian
- Degree: Degrees

Harmonic Analysis Items (Power Analysis Item)

Harmonic Analysis Items (Power Analysis Item)

Harmonic analysis results are output to RTmath15 and RTmath16. Select the check boxes for the measurement functions you want to output.

- All ON (All ON): The check boxes of all items are selected.
- All OFF (All OFF): The check boxes of all items are cleared.
- Default (default): The check boxes of only the default settings are selected.
- RMS(x)ON/OFF: Selects or unselects the RMS (rms values of the 1st to the 40th harmonic) check boxes collectively when the analysis mode is Line RMS.
- P(x)ON/OFF: Selects or unselects the P (active powers of the 1st to the 35th harmonic) check boxes collectively when the analysis mode is Power.
- Phdf(x)ON/OFF: Selects or unselects the Rhdf (percentage contents of the 1st to the 40th harmonic) check boxes collectively when the analysis mode is Line RMS and the Phdf (active power percentage contents of the 1st to the 35th harmonic) check boxes collectively when the analysis mode is Power.
- φ (x)ON/OFF: Selects or unselects the φ (phases of the 1st to the 40th harmonic) check boxes collectively when the analysis mode is Line RMS and the φ (active power phases of the 1st to the 35th harmonic) check boxes collectively when the analysis mode is Power.

All Items Output Setup (All Items Output Setup)

- Waveform color: Select the waveform color.
- Label (Label): Set the label using up to 16 characters.
- Upper/Lower (Upper/Lower): $-9.9999\text{E}+30$ to $+9.9999\text{E}+30$ in $1\text{E}-30$ steps

Harmonic Analysis Window Setup (Window Setup)

Harmonic Window Display ON/OFF (Display)

Set whether to display the harmonic window.

- ON: The window is displayed.
- OFF: The window is not displayed.

Computation Result Display Type (Type)

Select from the following.

- Bar graph ([Bar Graph](#)): A bar graph is displayed for the calculated harmonic value of each harmonic up to the 40th harmonic.
- List ([List](#)): A numerical list is displayed for the calculated harmonic value of each harmonic up to the 40th harmonic.
- Vector ([Vector](#)): The relationship of the phase difference and size (rms value) between the fundamental waves U(1) and I(1) of the source channel is displayed with vectors. Available when the analysis mode is Power.

Graph Position (Graph Position)

Select the analysis position on the waveform display of the main window. The analysis results for the cursor position are displayed in the graph window.

Selectable range: -5.00 div to 5.00 div

Main Window Ratio (Main Ratio)

▶ [See here.](#)

Window Layout (Window Layout)

Set the window layout when a combination of two windows—a harmonic window and another window (zoom window, X-Y window, or FFT window)—is displayed.

This is synchronized with the setup menu (Window Layout) of the zoom window, X-Y window, and FFT window.

- Side: Horizontal
- Vertical: Vertical (valid only when Main Ratio is set to 0 % when multiple X-Y windows are displayed)

When the Type Is Set to Bar Graph

- **Display Item (Display Item)**

Select whether to display the following items.

Line RMS mode: RMS (rms value), hrf (percentage content), ϕ (phase)

Power mode: P (active power), hrf (active power percentage content), ϕ (power phase)

- **Maximum Display Order (Maximum Display Order)**

Set the harmonics to display in the graph window.

The selectable ranges are as follows:

Line RMS mode: 1 to 40

Power mode: 1 to 35

- **Vertical Scale (V Scale)**

Set the vertical scale to Linear or Log (logarithmic).

This setting applies to the scales for RMS (rms value) and P (active power).

Graph display example

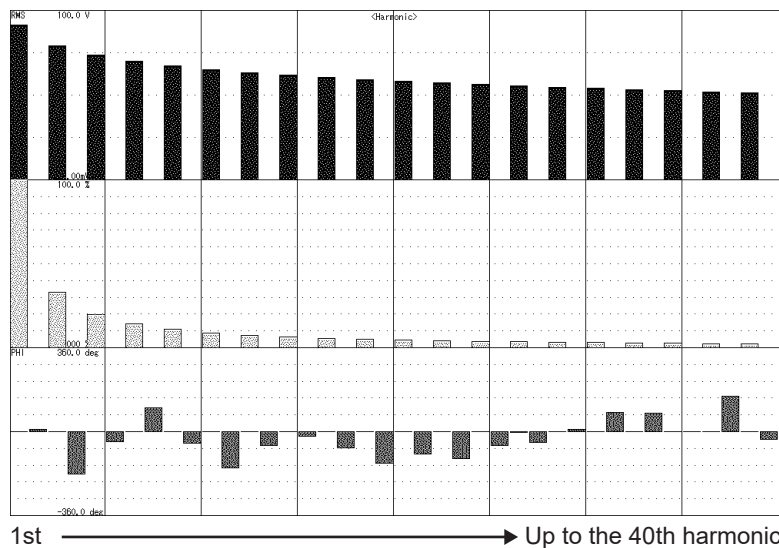

When the Type Is Set to List

- **Display Item (Display Item)**
This is the same as with Bar Graph.
- **Maximum Display Order (Maximum Display Order)**
This is the same as with Bar Graph.
- **List Start Order (List Start Order)**

Set the harmonic to display at the top of the list.
 Harmonics less than the specified harmonic are not shown in the list.
 This is used to scroll the list.
 The selectable ranges are as follows:
 Line RMS mode: 1 to 40
 Power mode: 1 to 35

List display example (rms and percentage content)

0000.00us		-2.560V		0.00us		1S	
(Harmonic)							
RMS(1)	439.76uV	Rhdf(1)	100.00%	PHI(1)	0.0000deg		
RMS(2)	336.25uV	Rhdf(2)	0.07646%	PHI(2)	29.827deg		
RMS(3)	309.18uV	Rhdf(3)	0.07031%	PHI(3)	13.905deg		
RMS(4)	130.52uV	Rhdf(4)	0.02960%	PHI(4)	18.422deg		
RMS(5)	51.560uV	Rhdf(5)	0.01172%	PHI(5)	2.5397deg		
RMS(6)	125.43uV	Rhdf(6)	0.02852%	PHI(6)	-0.3180deg		
RMS(7)	74.024uV	Rhdf(7)	0.01693%	PHI(7)	9.2695deg		
RMS(8)	89.910uV	Rhdf(8)	0.02045%	PHI(8)	-50.945deg		
RMS(9)	28.557uV	Rhdf(9)	0.00639%	PHI(9)	-29.118deg		
RMS(10)	66.699uV	Rhdf(10)	0.01517%	PHI(10)	-1.2610deg		
RMS(11)	37.559uV	Rhdf(11)	0.008540%	PHI(11)	-73.103deg		
RMS(12)	57.528uV	Rhdf(12)	0.01308%	PHI(12)	45.901deg		
RMS(13)	60.739uV	Rhdf(13)	0.01381%	PHI(13)	110.64deg		
RMS(14)	47.163uV	Rhdf(14)	0.01072%	PHI(14)	135.77deg		
RMS(15)	53.115uV	Rhdf(15)	0.01208%	PHI(15)	-26.071deg		
RMS(16)	63.362uV	Rhdf(16)	0.01441%	PHI(16)	62.599deg		
RMS(17)	53.623uV	Rhdf(17)	0.01219%	PHI(17)	172.69deg		
RMS(18)	65.881uV	Rhdf(18)	0.01498%	PHI(18)	72.518deg		
RMS(19)	83.982uV	Rhdf(19)	0.01910%	PHI(19)	-42.474deg		

Harmonics Harmonic analysis values

You can scroll by dragging the screen or by pressing the List Start Order soft key and turning the jog dial.

When the Type Is Set to Vector

- **Numeric Display ON/OFF (Numeric)**

Set whether to display the numeric measured results in the graph window.

ON: The numeric measured results are displayed.

OFF: The numeric measured results are not displayed.

- **Zoom (U:Zoom, I:Zoom)**

You can change the size of vectors. When you zoom the vectors, the value that indicates the size of the vector display's peripheral circle changes according to the zoom factor.

Selectable range: 0.1 to 100

When the wiring system is 3V3A (three-voltage three-current method), 3P3W→3V3A (conversion of three-phase three-wire system to the three-voltage three-current measurement method), or 3P4W→3V3A (star-delta transformation)

- U1(1), U2(1), and U3(1) are line voltages.
- I1(1), I2(1), and I3(1) are line currents.

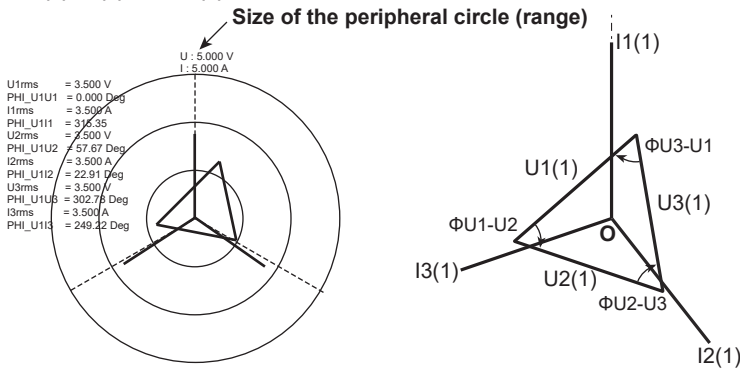

When the wiring system is 1P2W (single-phase two-wire), 1P3W (single-phase three-wire), 3P3W (three-phase four-wire), 3P4W (three-phase four-wire), or 3V3A→3P4W (delta-star transformation)

- U1(1), U2(1), and U3(1) are phase voltages.
- I1(1), I2(1), and I3(1) are line currents.

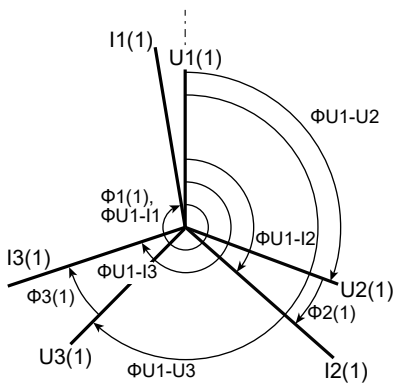

Numeric Monitor Mode (Digital Monitor Mode)

Select which waveform's channel information or numeric monitor to display when [channel information](#) is displayed on the screen from the following.

- Display Group (Display Group): The channel information or numeric monitor of the waveform in the selected display group is displayed.
- Power (Power): The channel information or numeric monitor of the power analysis results is always displayed, regardless of the selected display group.
- Harmonic (Harmonic): The channel information or numeric monitor of the harmonic analysis results is always displayed, regardless of the selected display group.

18 Printing and Saving Screen Captures

You can print screen captures on a USB printer or network printer or save them to files.

Target (Target)

You can save screen captures and print them on the following types of printers.

- **USB printer (USB Print):** The printer connected to the instrument through USB.
- **Network Printer (Network Print):** You can select a printer on the network that the instrument is connected to. You must configure the network printer in advance.
- **File (File):** You can save screen captures to files in PNG, BMP, and JPEG formats.

Printing on a USB Printer (USB Print)

A screen image of the instrument can be printed on a printer connected through USB.

USB Ports

This instrument has two standard type A USB ports and a standard type B USB port on on the left side panel. Connect the printer to one of the standard type A ports.

Left side panel



Type A



Type B

Pin No.	Signal Name
1	VBUS: +5 V
2	D- : -Data
3	D+ : +Data
4	GND: Ground

Printer Type (Format)

The following USB Printer Class Ver.1.0 printers can be used.

- HP Inkjet: HP inkjet printers, single function models
- Brother: Brother PocketJet or RJ-4030 printers



- Do not connect an incompatible USB printer.
- For USB printers that have been tested for compatibility, contact your nearest YOKOGAWA dealer.

Connection Procedure

Connect a USB printer directly to the instrument using a USB cable. You can connect or remove the USB cable regardless of whether the instrument is on or off (hot-plugging is supported). If you connect a USB printer when the instrument is on, the instrument will detect the printer and enable it for use.



- Connect the USB printer directly, not through a hub.
- Do not connect multiple printers to the USB ports.
- While the printer is printing, do not turn off the printer or remove the USB cable.
- Do not connect or remove USB cables from the time when the instrument is turned on until key operation becomes available (approximately 20 to 30 seconds).

Color (Color)

When the printer type is HP Inkjet, select the color mode from the following options.

- ON: Images are printed in color using the waveform colors displayed on the screen. The background is printed in white and the grid and boundary lines in black.
- OFF: Printing is performed in black and white.

Comment (Comment)

You can specify a comment using up to 26 characters. The comment appears at upper left of the screen. The comment is also used for printing on a network printer and saving files.



Notes on printing with a USB printer

- The comment may not be printed properly on some printers. Use a USB printer that has been tested for compatibility.
 - The instrument may not be able to detect out-of-paper or other errors on the USB printer. If an error occurs, press PRINT again to stop the printout.
-

Printing on a Network Printer (Network Print)

A screen image of the instrument can be printed on a network printer. You can select a printer that is on the network that the instrument is connected to. You must configure the network printer in advance.

▶ [See here.](#)

Printer Type (Format)

The printer type is fixed to PCL Laser (PCL laser printer).

Color (Color)

You can select the print color format from the following.

- ON: Images are printed in color using the waveform colors displayed on the screen. The background is printed in white and the grid and boundary lines in black.
- OFF: Printing is performed in black and white.

Comment (Comment)

You can specify a comment using up to 26 characters. The comment appears at upper left of the screen. The comment is also used for printing on a USB printer and saving files.

Saving Screen Captures to Files (File)

You can save screen captures to files in PNG, BMP, and JPEG formats.

Setting the Save Destination (Image Save Path Name),

Save Destination in Multi-Unit Synchronization Mode (/C50 option) (Destination)

Specify where to save the file. This is shared with the setting on the menu (save screen capture) that appears by pressing the FILE key.

▶ [See here.](#)

Auto Naming (Auto Naming), File Name (File Name)

The auto naming and file name settings are synchronized to the settings accessed from the menu that opens with the FILE key.

▶ [See here.](#)

Data Format (Format)

Set the data format to PNG, BMP, or JPEG. This is shared with the setting on the menu (save screen capture) that appears by pressing the FILE key.

▶ [See here.](#)

Color (Color)

You can set the screen capture color to color or black and white. This is shared with the setting on the menu (save screen capture) that appears by pressing the FILE key.

▶ [See here.](#)

Background Transparent or Opaque (Background)

Set the background when the screen capture is in PNG format. This is shared with the setting on the menu (save screen capture) that appears by pressing the FILE key.

▶ [See here.](#)

Comment (Comment)

You can specify a comment using up to 26 characters. The comment appears at upper left of the screen.

This is shared with the comment for the USB printer and network printer.

Printing and Saving Screen Captures (IMAGE SAVE key)

Prints screen captures on a specified printer or saves them to files.

19 Saving and Loading Data

You can save the following types of data.

- Waveform data
- Setup data
- Screen capture data
- Snapshot waveform data
- Automated measurement data
- FFT analysis result

You can load the following types of data into the instrument.

- Waveform data
- Setup data
- Snapshot waveform data

You can also rename and copy files and set or clear protection on files.

Storage Device You Can Save and Load From

The instrument can access the following five types of storage device for saving and loading data.

SD Memory Card (SD-1)

The SD memory card inserted into the SD memory card slot of the instrument.

USB Storage Device (USB-0/USB-1)

A USB storage device that is connected to the instrument's USB port. USB2.0 mass storage devices compatible with USB Mass Storage Class Ver. 1.1 can be connected to the instrument.

Internal SSD (Internal)

The internal SSD installed in models with the /ST1 option.

Network Drive (Network)

A storage device on the network. You can use a network storage device by connecting the instrument to an Ethernet network.



Notes about Using USB Storage

- Connect USB storage devices directly, not through a USB hub.
 - Only connect a compatible USB keyboard, mouse, or storage device to the USB port for peripherals.
 - Do not connect and disconnect multiple USB devices repetitively. Provide at least a 10-second interval between removal and connection.
 - Do not connect or remove USB cables from the time when the instrument is turned on until key operation becomes available (approximately 20 to 30 seconds).
 - You can use USB storage devices that are compatible with USB Mass Storage Class Ver. 1.1.
 - The instrument can handle up to four storage devices. If the connected device is partitioned, the instrument treats each partition as a separate storage device. As such, the instrument can handle up to four partitions.
 - Do not connect USB storage device to the instrument during SSD recording or when you will start SSD recording.
-

Saving Waveform Data (Waveform)

You can save the waveform data that the instrument has measured to a file in binary, ASCII, or MATLAB format.

Save Destination (File List)

This is a setting for when synchronous operation is not being performed in multi-unit synchronization mode (/C50 option).

On the file list (File Dialog), specify the save destination.

▶ [See here.](#)

Save Destination in Multi-Unit Synchronization Mode (/C50 option) (Destination)

This is a setting for when synchronous operation is being performed in multi-unit synchronization mode (/C50 option).

Specify the data save destination device (SD-1, USB-0/USB-1, Internal, Network). You cannot specify a sub folder in a storage device.

When you specify the save destination device, a fixed area (REMOTE) is automatically created in its root directory. In addition, a date_time folder is automatically created in the fixed area, and data is saved in it. The following suffix is added to the end of the file name of the saved data set by the auto-naming feature.

- Main unit: _Main
- Sub unit: _SubN (N = 1 to 4)

File name (File Name)

Set the file name.

- You can also use the auto naming feature to automatically assign file names.
- When saving in binary format, whether Auto Naming is set to Numbering, Date, or OFF, when the size of a single file exceeds 2 GB, an underscore and a three-digit serial number (000 to 999) are appended to the file names.

File Name Example for When Auto Naming Is Set to Date

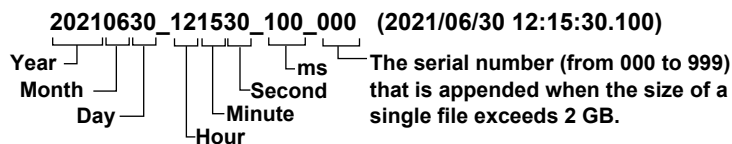

- The underscore and three-digit serial number are not appended to the file name when the file size is 2 GB or less. However, for a file is saved through the SSD recording feature, an underscore and the three-digit serial number 000 are appended to the file name even if the file size does not exceed 2 GB.

Auto Naming (Auto Naming)

- Numbering (Numbering)
The instrument automatically adds a four-digit number from 0000 to 9999 after the common name specified using the File Name setting (up to 32 characters) and saves files.
- Date (Date)
The file name is the date and time (down to ms) when the file is saved. The file name specified using the File Name setting is not used.
- OFF
The auto naming feature is disabled. The name that you specify using the File Name setting is used. If there is a file with the same name in the save destination folder, you cannot save the data.

File name (File Name)

You can set the common file name that is used when the auto naming feature is turned off or when the auto naming feature is set to Numbering. The maximum number of characters that you can use for file names and folder names is 32 characters. The following restrictions apply.

- Of those characters on the keyboard that appears on the screen, the characters that can be used are 0-9, A-Z, a-z, _, -, =, (,), {, }, [,], #, \$, %, &, ~, !, `, and @. @ cannot be entered consecutively.
- The following exact strings cannot be used due to MS-DOS limitations:
AUX, CON, PRN, NUL, CLOCK, LPT1, LPT2, LPT3, LPT4, LPT5, LPT6, LPT7, LPT8, LPT9, COM1, COM2, COM3, COM4, COM5, COM6, COM7, COM8, COM9
- Keep the full path name (absolute path from the root folder) within 255 characters. If this is exceeded, an error will occur when you perform file operations (save, copy, rename, create folder, etc.). When an operation is being performed on a folder, the full path is up to the name of the folder. When an operation is being performed on a file, the full path is up to the name of the file.

The following additional restrictions apply when you use the file name auto naming feature.

- If you set auto naming to Numbering, the file name will be the common name that you specify as the file name with a 4-character sequence number.
- If you set auto naming to Date (date and time), the characters that you entered for the file name will not be used. File names will only consist of the date information.

Comment (Comment)

You can add a comment that consists of up to 120 characters when you save a file. You do not have to enter a comment. All characters, including spaces, can be used in comments.

Data Type (Data Type)

Select whether to save in the following data formats.

When Dual Capture Is On in Scope Mode

- [All Data Binary Save \(All Data Binary\)](#)

Low-speed sampling data

- [ASCII \(ASCII\)](#)
- [MATLAB](#)

High-speed sampling data

- [Binary \(Binary\)](#)
- [ASCII \(ASCII\)](#)
- [MATLAB](#)

When Dual Capture Is Off in Scope Mode

- [Binary \(Binary\)](#)
- [ASCII \(ASCII\)](#)
- [MATLAB](#)

Recorder Mode

- [Binary \(Binary\)](#)
- [ASCII \(ASCII\)](#)
- [MATLAB](#)

All Data Binary Save (All Data Binary)

When dual capture is on, the sampled data of low-speed sampling and high-speed sampling (all waveforms for history) stored in the acquisition memory is saved in a single file in [binary format](#).

Binary (Binary)

- The sampled data stored in the acquisition memory is saved to a file in binary format. The extension is .WDF. A thumbnail file is also saved at the same time. The thumbnail file can be viewed in the file property (File Property) screen.
- You can set this only for high-speed sampling when dual capture is on. Two characters “_HS” are appended to the file name.
- You can load the saved binary format data into the instrument, display the waveform of the data, and view the values that it contains. Accumulate is always set to OFF for loaded data.
- The instrument numbers of the DL950 and each module are saved in the file properties. However, the instrument numbers of the following modules are not saved.

701250, 701251, 701255, 701261, 701262, 701265, 701270, 701271, 701275, 720230, 720240

ASCII (ASCII)

- The sampled data stored in the acquisition memory is converted using the specified range and saved to a file in ASCII format. The extension is .CSV. You can use the file to analyze waveforms on your PC.
- When dual capture is on, you can set this for low-speed sampling and high-speed sampling. Two characters, “_LS” for low-speed sampling and “_HS” for high-speed sampling, are appended to the file name.
- You cannot load this type of data into the instrument.
- If the file size would exceed 2 GB to create the file, saving is not possible.
- If the main channel sample rate and the rate at which data is written to the sub channel acquisition memory are different, “NAN” may be present in the start section of the sub channel data. The minimum number of NAN points is zero. The maximum is according to the following equation.

$$\frac{\text{Main channel sample rate}}{\text{Rate at which data is written to the sub channel acquisition memory}}$$

MATLAB

- The sampled data stored in the acquisition memory is saved to a file in MATLAB format. You can select whether to include text format information (ON) or not (OFF). The extension is .MAT. You can use the file to analyze waveforms on your PC.
- You cannot load this type of data into the instrument.
- When dual capture is on, you can set this for low-speed sampling and high-speed sampling. Two characters, “_LS” for low-speed sampling and “_HS” for high-speed sampling, are appended to the file name.
- If the file size would exceed 2 GB to create the file, saving is not possible.
- Waveform data files conform to Level-5 MAT format. Files are not compressed.

Data Size

The data sizes indicated below are for when the record length is 100 kpoint and you save the measured data from CH1 to CH4 with all computed waveforms turned off and one history waveform.

Data Type	Extension	Size (In bytes)
Binary	.WDF	Approx. 1.45 M ((100 kpoint) × 4 channels × 2) + internal setup data (700 k to 2 M depending on the installation state)
ASCII	.CSV	4 to 5 Mpoint
MATLAB	.MAT	Approx. 1.6 M: (100 kpoint) × 4 channels × 4, 1 byte per bit for logic signals

Save Range (Range)

You can select the waveform save range (area) from one of the choices below.

When Dual Capture Is Off in Scope Mode

- Main (Main): Saves the data displayed in the main window
- Zoom1, Zoom2 (Zoom1, Zoom2): Saves the range of data displayed in the zoom window
- Cursor range (Cursor Range): Saves the data in the area between the cursors

When Dual Capture Is On in Scope Mode

- **Low-Speed Sampling Save Range (Low Speed Save Range)**
 - Main (Main): Saves the data displayed in the main window
 - Zoom (Zoom): Saves the range of data displayed in the zoom window
- **High-Speed Sampling Save Range (High Speed Save Range)**
 - Main (Main): Saves the data displayed in the main window
 - Zoom (Zoom): Saves the range of data displayed in the zoom window

Recorder Mode

- All (All): Saves the data of all measured waveforms
- Display area (Display Area): Saves the data in the area shown in the main window
- Zoom (Zoom): Saves the range of data displayed in the zoom window
- Cursor range (Cursor): Saves the data in the area between the cursors

Cursors (Cursor1, Cursor2)

When the save range is set to Cursor, set the save range with Cursor 1 and Cursor 2.

You can set the range anywhere between -5 and $+5$ divisions from the center of the waveform display window.

- Scope mode: Set the positions in divisions.
- Recorder mode: When the time base is internal, set the positions in terms of the time (ddhhmmss) corresponding to divisions. When the time base is external, set the positions in terms of points (0 to record length).

The start and end points are similar to the settable range of the cursor display position in cursor measurement.

For details, see "Selectable Range of Cursor Positions." ► [See here.](#)

Waveform Data Save Setup (Waveform Save Setup)

Binary (Binary)

• Saving History Waveforms (History)

When saving data in binary format in Scope mode, select one of the settings below.

- One waveform (One): Only the waveform with the record number specified in the history menu is saved.
- All waveforms (All): All history waveforms between the start and end numbers specified in the History menu are saved.



- When dual capture is on, all high-speed sampling waveforms and low-speed sampling waveforms are saved for all data binary save. For high-speed sampling binary save, the displayed, single high-speed sampling waveform is saved.
- Average waveforms of history waveforms cannot be saved. To display the average waveform, save the necessary range of history waveforms using All, load the saved history waveforms, and then set the display mode of the history function to Average Record.
- When saving in ASCII or MATLAB format, history waveforms cannot be saved.

19 Saving and Loading Data

- **P-P Compression (P-P Comp)**

When saving data in binary format, you can select whether to apply P-P compression on waveform data.

- ON: Data is saved by applying P-P compression.
- OFF: Data is saved without applying P-P compression.



P-P compression is not applied when the data format is All Data Binary and dual capture is on.

ASCII (ASCII)

- **Time Information (Time Info.)**

When you save data in ASCII format, you can choose whether to save time information.

- ON: Time information is saved.
- OFF: Time information is not saved.

- **Decimal Point (Decimal Point)**

When you save data in ASCII format, you can select the decimal point and separator (data separation).

- Point (Point): The decimal point is a period, and the separator is a comma.
- Comma (Comma): The decimal point is a comma, and the separator is a period.

- **Interpolation Method When the Sample Rate Is Different on Each Channel (Different SampleRate)**

When the sample rate is different on each channel, you can select the interpolation method for waveform data acquired at slow sample rates.

- Supplement (Supplement): The data is interpolated using same values so that the number of data points is the same as that of the waveform data acquired at the highest sample rate.
- Space (Space): Spaces are left where there is no data.

Notes about Using the 16-CH Temperature/Voltage Input Module (720221)

▶ [See here.](#)

MATLAB

- **Whether to Include Text Format Information (Information Text).**

When you save data in MATLAB format, you can choose whether to include text format information.

Save Trace Selection (Select Save Trace)

- Select the waveforms you want to save from CH1 to CH16,¹ 16chTEMP/VOLT,² CAN,³ LIN,³ SENT,³ RTmath1 to RTmath16, and Math1 to Math8. Only the waveforms whose input is turned on are saved.
 - 1 You can select the channels of installed modules (including sub channels of 4-CH modules).
 - 2 When a 16-CH Temperature/Voltage Input Module is installed. You cannot select sub channels.
 - 3 On models with the /VCE option when a CAN bus monitor, CAN/CAN FD monitor, CAN & LIN bus monitor, or SENT monitor module is installed. You cannot select sub channels.
- The vertical-axis, horizontal-axis, and trigger settings are also saved along with the waveforms.

Saving (Execute Save)

Saves the data to the specified save destination with the specified file name.

While saving is in progress, the button changes to Abort (Abort).



-
- If you change the extension of the saved data file, by using a PC or some other device, the instrument will no longer be able to load it.
 - Up to 1000 files and folders can be displayed in the file list. If there are more than a total of 1000 files and folders in a given folder, the file list for that folder will display only 1000 files and folders. There is no way to set which files and folders are displayed.
 - When saved dual capture high-speed sampling waveform data is loaded in this instrument, the data can be resaved. However, high-speed sampling waveform data obtained in auto (Auto) mode with data existing in an area in which 10 divisions of low-speed sampling waveform data cannot be retained cannot be resaved if it is loaded.
-

Saving Setup Data (Setup)

You can save the instrument setup information to the specified storage device. The extension is .SET.

Save Destination (File List)

The save destination applies to waveform data, setup data, and other types of data (excluding screen captures).

▶ [See here.](#)

Auto Naming (Auto Naming), File Name (File Name)

Auto naming and file name settings apply to waveform data, setup data, and other types of data.

▶ [See here.](#)

Comment (Comment)

Comments apply to waveform data, setup data, and other types of data (excluding screen captures).

▶ [See here.](#)

Saving (Execute Save)

▶ [See here.](#)

Storing to the Internal Memory

You can save setup data to the internal memory on the save/load menu.

▶ [See here.](#)

Saving Other Types of Data (Others)

You can save screen captures, FFT analysis results, and so on. Select the type of data you want to save.

Save Destination (File List)

The save destination applies to waveform data, setup data, and other types of data (excluding screen captures).

If the data type is screen captures, the save destination is the same as that for screen captures saved with the SAVE and IMAGE SAVE keys.

▶ [See here.](#)

Auto Naming (Auto Naming), File Name (File Name)

Auto naming and file name settings apply to waveform data, setup data, and other types of data.

▶ [See here.](#)

Comment (Comment)

- **When the Data Type Is Screen Capture** ▶ [See here.](#)

The comment also applies to screen captures saved with the SAVE and IMAGE SAVE keys.

- **When the Data Type Is Not Screen Capture** ▶ [See here.](#)

The comment also applies to waveform data, setup data, and other types of data (excluding screen captures).

Data Type (Data Type)

Select the data you want to save from the following.

- **Screen captures (Screen Image)**: You can save the displayed screen image to a file in PNG, BMP, or JPEG. You can set the save destination and comment separately from other data types. You can also save screen images with the **IMAGE SAVE** or **SAVE key**.
- **Snapshot waveforms (Snap)**: You can save the waveform data captured in a snapshot. The extension is .SNP.
- **Measure (Measure)**: You can save the results of the automated measurement of waveform parameters to a file in CSV format.
- **FFT (FFT)**: You can save FFT analysis results to a file in CSV format.

Screen Captures (Screen Image)

Data Format (Format)

You can select the format to save to from the options listed below.

- PNG: The extension is .PNG. The file size is approximately 50 KB when you save a monochrome screen capture and approximately 100 KB when you save a color screen capture.
- The extension is .BMP. The file size is approximately 150 KB when you save a monochrome screen capture and approximately 2 MB when you save a color screen capture.
- The extension is .JPG. The file size is approximately 250 KB for color mode.



The file sizes listed here are for reference. Actual file sizes will vary depending on the image that is saved.

Color (Color)

You can select the color format to save to from the options below.

- ON: Saves data using 65536 colors.
- ON (Gray): Saves data using 16 grayscale levels.
- ON (Reverse): Saves data using 65536 colors. The image background will be white. You cannot select this option when the color theme on the DISPLAY menu is set to default in Recorder mode or when the color theme is set to white.
- OFF: Saves data in black and white.

Background Transparent or Opaque (Background)

For PNG format, you can save the waveform display area with a transparent background. This feature is convenient when you want to compare waveforms by overlaying screen captures on the PC.

- Normal (Normal): Saves data without changing the background (not made transparent).
- Transparent (Transparent): Saves data by making the background transparent.

Automated Measurement Values of Waveform Parameters (Measure)

Save the results of automatic waveform parameter measurement to a file in CSV format. The extension is .CSV. CSV files are text files that contain data separated by commas. They are used to convert data between spreadsheet and database applications.

The maximum number of previous values that you can save is equal to $100000 \div$ number of items that are turned on.

Data size in bytes = Number of measured items \times 15 \times number of history waveforms

Save Conditions (Measure Save Setup)

- **Unit (Unit)**

You can select whether to save the units of measure along with the measured results.

- ON: Units are saved.
- OFF: Units are not saved.

- **Time Information (Time Info.)**

▶ [See here.](#)

FFT Analysis Results (FFT)

You can save the analysis results of FFT1 or FFT2 to a file in CSV format. The extension is .CSV.

Save Conditions (FFT Save Setup)

- **Frequency Information (Frequency Info.)**

You can select whether to save frequency information along with computed results.

- ON: Frequency information is saved.
- OFF: Frequency information is not saved.

- **Decimal Point (Decimal Point)**

▶ [See here.](#)

Saving (Execute Save)

▶ [See here.](#)

Saving Data (SAVE key)

The instrument saves data to the specified storage device.

Specifying the Data to Save

Set whether to save the following data.

- Waveform data in binary format (Binary)
- Waveform data in ASCII format (ASCII)
- Waveform data in MATLAB format (MATLAB)
- Screen captures (Save Image)

Save Settings (Save Setup)

Auto Naming (Auto Naming), File Name (File Name)

The auto naming and file name settings are synchronized to the settings accessed from the menu that opens with the FILE key.

▶ [See here.](#)

Saving Waveforms (Waveform Save)

Select the check box for the data type (binary (Binary), ASCII (ASCII), MATLAB) to save the waveforms in.

- **Save Destination (Path), Save Destination in Multi-Unit Synchronization Mode (/C50 option) (Destination)**

Specify where to save the waveforms. This is shared with the setting on the menu (save waveform data) that appears by pressing the FILE key.

▶ [See here.](#)

- **Comment (Comment)**

Set a comment that you want to attach to the saved waveform file. This is shared with the setting on the menu (save waveform data) that appears by pressing the FILE key.

▶ [See here.](#)

- **Waveform Save Detail Setup (Wave Save Detail Setup)**

This is shared with the setting on the menu (save waveform data) that appears by pressing the FILE key.

▶ [See here.](#)

- **Save Trace Selection (Select Save Trace)**

This is shared with the setting on the menu (save waveform data) that appears by pressing the FILE key.

▶ [See here.](#)

Image Save (Image Save)

To save screen captures, select the Image (Image) check box.

- **Save Destination (Path)**

Specify where to save the screen captures. This is shared with the setting on the menu (save screen capture) that appears by pressing the FILE key.

▶ [See here.](#)

- **Comment (Comment)**

Set a comment that you want to attach to the screen capture. This is shared with the setting on the menu (save screen capture) that appears by pressing the FILE key.

- **Image Save Detail Setup (Image Save Detail Setup)**

Set the format (Format), color (Color), and background (Background). This is shared with the setting on the menu (save screen capture) that appears by pressing the FILE key.

▶ [See here.](#)

Waveform Save Range Setup (Wave Save Range Setup)

This is shared with the setting on the menu (save waveform data) that appears by pressing the FILE key.

Loading Data (Load)

You can load waveform data, setup data, and snapshot waveforms that have been saved.

Loading Waveform Data (Waveform)

Waveform data in binary format (files with .WDF extensions) can be loaded.

You can load a specified waveform data file with the setup data. All the data in the file is loaded. Waveforms of computed data appear when computation is turned on. Because setup data is also loaded, the instrument settings change when you load the waveform data. If you start waveform acquisition by pressing the START/STOP key, the loaded data is cleared.



- P-P compressed binary data cannot be loaded.
- Binary data that has been resaved after loading SSD recording data cannot be loaded.
- If the module configuration when the waveform data is saved and that when the data is loaded are different, only the waveform data of modules that match is loaded. When loading is complete, a message indicating the channel numbers that were not loaded is displayed.
- If only the high-speed sampling waveforms of dual capture are saved in binary, when the saved waveform is loaded, the waveform is displayed with dual capture in the off state. If you want to display the waveform with dual capture in the on state, save the waveforms with the data format set to All Data Binary (which includes the low-speed sampling waveform).

Loading Waveform Data from Models with Different Options

In the following cases, waveform data saved on models with different options can be loaded.

Memory Option

Option of the DL950 that waveform data was saved on	Option of the DL950 that waveform data will be loaded into (Y: Loadable)		
	No options (1 Gpoint)	/M1 (4 Gpoint)	/M2 (8 Gpoint)
No options (1 Gpoint)	Y	Y	Y
/M1 (4 Gpoint)	Y ^{1,2}	Y	Y
/M2 (8 Gpoint)	Y ^{1,2}	Y ^{1,2}	Y

- 1 Waveform data can be loaded if all the following settings were used to save the data.
 - History waveform save setting: One waveform (One)
 - Dual capture setting: Off
- 2 Waveform data with set record length exceeding 10 Mpoint (including SSD recording) cannot be loaded.

Math Option

Option of the DL950 that waveform data was saved on	Option of the DL950 that waveform data will be loaded into (Y: Loadable)		
	Without the /G03 or /G05 option	/G03 (real time math)	/G05 Power math function (including real time math function)
Without the /G03 or /G05 option	Y	Y	Y
/G03 (real time math)	Y ¹	Y	Y
/G05 Power math function (including real time math function)	Y ¹	Y ²	Y

- 1 Waveform data of real time math and power math channels cannot be loaded.
- 2 Waveform data of power math channels cannot be loaded.

Loading Setup Data (Setup)

The setup data of the specified file is loaded. The extension is .SET.

However, the following settings will not be changed.

Time settings, time synchronization feature (IRIG and GPS available on the /C35 option), storage device format, USB keyboard language, USB communication feature, color theme, click sound ON/OFF, key protection, network

Recalling from Internal Memory

Setup data can be loaded from the internal memory on the save/load menu.

▶ [See here.](#)



If the module configuration when the setup data is saved and that when the data is loaded are different, only the setup data of modules that match is loaded. When loading is complete, a message indicating the channel numbers that were not loaded is displayed.

Loading Other Types of Data (Others)

This is a setting available in Scope mode.

The snapshot waveforms of the specified file or the contents of a symbol definition file are loaded.

Snapshot Waveforms (Snap)

The extension is .SNP. The snapshot waveforms that you load are displayed in white on the screen.

Symbol Definition Files (Symbol)

This is available when a CAN bus monitor, CAN/CAN FD monitor, or CAN & LIN bus monitor module is installed.

The symbol definition file is loaded into the specified load destination channel (specified by Load to).

The extension is .SBL. These are [CAN data](#) or [LIN data](#) definition files.

Loading Symbols (Symbol)

This is a setting available in Recorder mode. This is available when a CAN bus monitor, CAN/CAN FD monitor, or CAN & LIN bus monitor module is installed.

The symbol definition file is loaded into the specified load destination channel (specified by Load to).

The extension is .SBL. These are [CAN data](#) or [LIN data](#) definition files.

Starting to Load (Load)

Loads the data of the specified file.

File Operations (Utility)

You can perform file operations such as creating folders on the storage device, deleting and copying files, and changing file names.

Display Format (*)

Select whether to display the file list in a one-column list, two-column list, or using thumbnails.

* The icon that is displayed varies depending on the display format.

List Sorting (*)

You can sort the file list by file name, data size, date, etc.

* The icon that is displayed varies depending on what is being sorted.

Selecting the Type of Files to List (*)

You can limit the type of files that appear in the list by selecting an extension.

* The icon that is displayed varies depending on the file type.

Displaying the Parent Folder ()

Displays the parent folder. When the top folder is displayed, you can change the storage device. The instrument displays various storage device as follows:

- SD-1: The SD memory card inserted into the SD memory card slot of the instrument
- USB-0: The first detected USB storage device that is connected to a instrument's USB port (type A) for connecting peripheral devices
- USB-1: The second detected USB storage device that is connected to a instrument's USB port (type A) for connecting peripheral devices
- Internal: Internal SSD (/ST1 option)
- Network: A storage device on the network

Selection Mode (Select)

Select the file selection method from below.

 (file selection): Tap a file displayed in the file list to select it. Check marks are displayed next to the selected files. You can select multiple files.

 (select all): Selects all the files displayed in the file list.

 (unselect all): Unselects all the files displayed in the file list.

Making Folders (Directories) (New folder)

You can make folders.

You can use the same characters in folder names that you can in file names.

▶ [See here.](#)

Copying and Moving Files (Copy and Move)

You can copy or move selected files and folders to other storage device or folders. You can copy or move multiple files at the same time.

Renaming Files and Folders (Rename)

You can rename a selected file or folder.

Protection ON/OFF (Protect OFF/ON)

Turns on or off the protection of the selected file. A  (key mark) is displayed next to the protected files.

Protection	Description
ON	The selected files are protected. The file can be read from. Writing is not allowed. Deleting is also not allowed.
OFF	The selected files are not protected. The file has read and write access.

Deleting Files and Folders (Delete)

You can delete selected files and folders.

File Properties (File Property)

You can view information about the selected file, such as its name (File Name), file size (File Size), the date and time when it was saved (Date/Time), and its attributes (Attribute).

For binary waveform data (the extension is .WDF), you can view the instrument numbers of the DL950 and each module as file properties.

However, you cannot view the instrument numbers of the following modules.

701250, 701251, 701255, 701261, 701262, 701265, 701270, 701271, 701275, 720230, 720240



- You can format a storage device using the storage manager (Storage Manager) on the System Config menu that appears by pressing the UTILITY key.
▶ [See here.](#)
 - You can cancel a file operation by tapping Abort (Abort) on the screen that appears while files are being copied, deleted, or moved. However, files that are already being processed are not applicable.
-

20 Ethernet Communication (Network)

You can configure TCP/IP parameters and use the optional Ethernet interface to perform the following tasks.

TCP/IP 10G, TCP/IP

TCP/IP settings for connecting to an Ethernet network.

Set the IP address, subnet mask, and default gateway.

▶ [See here.](#)

FTP Server (FTP/Web Server)

You can connect the instrument as an FTP server to a network.

You can connect to the instrument from a PC on the same network and retrieve waveform data.

▶ [See here.](#)

Web Server (FTP/Web Server)

You can connect the instrument as a Web server to a network.

You can connect to the instrument from a PC on the same network and monitor the instrument display from the PC.

▶ [See here.](#)

Mail (Mail)

The action can be set to mail transmission.

▶ [See here.](#)

Network Printer (Net Print)

You can specify a network printer for printing screen captures.

10GBASE-R is not supported.

▶ [See here.](#)

Network Drive (Net Drive)

You can save waveform data and setup data to a network drive.

▶ [See here.](#)

SNTP

The instrument clock can be set using SNTP. The instrument can be configured to automatically adjust its clock when it is turned on.

▶ [See here.](#)



To connect a PC to the instrument, use a hub or router, and connect to a network. Do not connect a PC directly to the instrument.

TCP/IP10G (TCP/IP10G), TCP/IP (TCP/IP)

Configure the settings that the instrument needs to connect to a network.

- TCP/IP 10G: Configure the 10GBASE-R Ethernet settings. (/C60 option)
- TCP/IP: Configure the 1000BASE-T/100BASE-TX/10BASE-T Ethernet settings.

DHCP

DHCP is a protocol that temporarily allocates settings that a PC needs to connect to the Internet.

To connect to a network that has a DHCP server, turn the DHCP setting on. When DHCP is turned on, the IP address can be automatically obtained when the instrument is connected to a network. (You do not have to set it manually.)

If you set DHCP to OFF, set the appropriate IP address, subnet mask, and default gateway for your network.

DNS

DNS is a system used to associate Internet host names and domain names with IP addresses. Given AAA.BBBBB.com, AAA is the host name and BBBBB.com is the domain name. You can use host names and domain names to access the network instead of using IP addresses, which are just numbers. The instrument allows you to specify the host by name, instead of by IP address. Set the domain name and the DNS server address (0.0.0.0 by default). For details, consult your network administrator.

DNS Servers (DNS Server1/DNS Server2)

You can specify up to two DNS server addresses: primary and secondary. If querying fails with the primary DNS server, the secondary DNS server is automatically used to find the mapping of the host name and domain name to the IP address.

Domain Suffixes (Domain Suffix1/Domain Suffix2)

The domain suffix is a piece of information that is automatically added when a query is made to a DNS server using only a portion of the domain name. For example, if BBBBB.co.jp is registered as a domain suffix and a query is made using "AAA," the name "AAA.BBBBB.co.jp" is searched for.

You can specify up to two domain suffixes: Domain Suffix1 and Domain Suffix 2.

You can use up to 127 characters. The characters that you can use are 0 to 9, A-Z, a-z, and dashes.

TCP/IP settings are applied when you select Bind and press SET in the dialog box or when you turn on the instrument the next time.

Bind (Bind)

The settings are applied, and the setup dialog box closes.

FTP Server (FTP/Web Server)

You can connect the instrument as an FTP server to a network.

Set the user name and password that will be used by devices on the network to access the instrument. Also, set the access timeout value.

User Name (User Name)

Set the user name that will be used to access the instrument from a PC. The characters that you can use are all the ASCII characters on the keyboard. If you set the user name to "anonymous," you can connect to the instrument without entering a password.

Password (Password)

Set the password that will be used to access the instrument from a PC. The characters that you can use are all the ASCII characters on the keyboard.

Timeout (TimeOut (sec))

If an ftp connection cannot be established between the instrument and the PC within the amount of time specified here, the instrument aborts the connection process.

Interface (Interface)

Select the Ethernet you want to use, 1G or 10G. (/C60 option)



To apply the settings that you specified, press Entry.

FTP Server Overview

When the instrument is connected to the network as an FTP server, the following features become available.

FTP Server Feature

You can view a list of files that are stored in a storage device that is connected to the instrument and transfer the files to the PC.

Operating System

A PC running the English or Japanese version of Windows 8.1 (32 bit or 64 bit) or Windows 10 (32 bit or 64 bit)

Web Server (FTP/Web Server)

You can connect the instrument as a Web server to a network.

Set the user name and password that will be used by devices on the network to access the instrument.

User Name (User Name)

Set the user name that will be used to access the instrument from a PC. The characters that you can use are all the ASCII characters on the keyboard. If you set the user name to “anonymous,” you can connect to the instrument without entering a password.

Password (Password)

Set the password that will be used to access the instrument from a PC. The characters that you can use are all the ASCII characters on the keyboard.

Interface (Interface)

Select the Ethernet you want to use, 1G or 10G. (/C60 option)



To apply the settings that you specified, press Entry.

Web Server Overview

When the instrument is connected to the network as an Web server, the following features become available.

Web Server Feature

You can display and control the instrument’s screen and operation panel from a browser on your PC via Ethernet.

Controlling from a PC

- Overview: An overview of the instrument, such as the model name and serial number, is displayed on a browser on your PC.
- Remote: The instrument’s screen and operation panel are displayed on a browser on your PC. The instrument’s screen displayed on the PC can be saved to a file.
You can set the screen update interval to OFF, 200 ms, 500 ms, 1 s, 3 s, or 5 s. However, updating may be delayed from the specified update interval depending on the communication status and the load status of the instrument.
- Remote control: You can control the screen and panel in the remote display state.
Some of the instrument’s operations are not supported. Nor can you turn on or off the instrument.
- File downloading: You can download files stored in the internal storage of this instrument (/ST1 option) or files stored in a USB device or SD memory card (2.5 MB or less) connected to this instrument to a PC.

Operating System

▶ [See here.](#)

Mail (Mail)

You can send trigger times and other information in emails to a specific email address as an action in the action feature.

Mail Server (Mail Server)

Specify the IP address of the mail server on the network that the instrument will use. In a network with a DNS server, you can specify the host name and domain name instead of the IP address.

Mail Address (Mail Address)

You can specify multiple email recipient addresses. Separate each address with a comma.

Comment (Comment)

If necessary, you can enter a comment in the first line of e-mails.

Attaching Image Files (Attached Image File)

You can attach a capture of the screen that is displayed at the time the email is sent.

File format: The format that you set in the FILE menu for saving screen captures.

File name: DL_image[time].extension

(Example : DL Image2102011158.extension -> Data at 11:58 on February 1, 2021)

Resolution: XGA (1024 × 768 dots)

Approximate File Size

Normal screen: Approx. 50 KB

Maximum: Approx. 1.6 MB (when the screen contains many colors)

Timeout (TimeOut (sec))

If the instrument cannot send an email for the amount of time specified here, it disconnects from the mail server.

Interface (Interface)

Select the Ethernet you want to use, 1G or 10G. (/C60 option)

Sending a Test Mail (Send Test Mail)

You can send a test mail to check whether emails can be sent properly.

Network Printer (Net Print)

You can print screen captures on a network printer.
Only PCL laser printers (PCL Laser) are supported.

LPR Servers (LPR Server)

Specify the IP address of the printer server that the instrument will connect to. In a network with a DNS server, you can specify the host name and domain name instead of the IP address.



LPR is a protocol used to print over a TCP/IP network.

LPR Name (LPR Name)

The name of the shared printer that the instrument will connect to.

Timeout (TimeOut (sec))

If the instrument cannot print for a certain amount of time, it disconnects from the network printer.

Network Drive (Net Drive)

You can save waveform data and setup data to a network drive.

FTP Servers (FTP Server)

Specify the IP address of the FTP server on the network that you want to save waveform or setup data to. In a network with a DNS server, you can specify the host name and domain name instead of the IP address.

Login Name (Login Name)

Specify the login name. The characters that you can use are all the ASCII characters on the keyboard.

Password (Password)

Specify the password that corresponds to the login name. The characters that you can use are all the ASCII characters on the keyboard.

Passive Mode (Passive)

Turn FTP passive mode on or off.

In passive mode, the FTP client sets the port number for data transfer. Enable passive mode when you have set an external FTP server as a network drive or when you are accessing an FTP server through a firewall.

Timeout (TimeOut (sec))

If the instrument cannot transfer files for a certain amount of time, it disconnects from the FTP server.

Interface (Interface)

Select the Ethernet you want to use, 1G or 10G. (/C60 option)

Connecting to the Network Drive (Connect/Disconnect)

When you press the Connect button, the instrument connects to the specified network drive, and the drive appears in the file list (File List). When you press the disconnect button, the network drive is disconnected and removed from the file list (File List).



If the network drive or fixed IP address is not set correctly, you may not be able to operate the instrument for the specified timeout period.

SNTP (SNTP)

The instrument clock can be set using Simple Network Time Protocol (SNTP). The instrument can be configured to automatically adjust its clock when it is turned on.

SNTP Server (SNTP Server)

Specify the IP address of the SNTP server that the instrument will use. In a network with a DNS server, you can specify the host name and domain name instead of the IP address.

Timeout (TimeOut (sec))

If the instrument cannot connect to the SNTP server for a certain amount of time, it aborts the operation.

Automatic Adjustment (Adjust at Power On)

You can configure the instrument so that its clock is automatically synchronized to the SNTP server clock when the instrument is turned on when it is connected to the network.

Interface (Interface)

Select the Ethernet you want to use, 1G or 10G. (/C60 option)

Executing Time Adjustment (Adjust)

The instrument clock is synchronized to the SNTP server clock.



-
- If the time difference from Coordinated Universal Time (UTC) is set in the date/time setting, the instrument will make appropriate adjustments to the time information received from the SNTP server.
▶ [See here.](#)
 - If you do not want the instrument to synchronize with an SNTP server, do not set the SNTP server IP address.
-

21 Time Synchronization

Time Synchronization Method (Time Sync)

Select the time synchronization method from the following.

OFF

The time is not synchronized. Set the time through the date and time setting in System Config.

GPS (/C35 option)

The time is synchronized using Coordinated Universal Time (UTC) received from Global Positioning System (GPS) satellites. A GPS unit (720940), sold separately, is required. GPS leap seconds are automatically obtained by the GPS unit.

IRIG (/C35 option)



The time is synchronized using Inter Range Instrumentation Group (IRIG) signals. IRIG signals can be applied through the IRIG input terminal of this instrument. Using IRIG setup (IRIG Setup), you can set the IRIG code format, IRIG code modulation type, and input impedance.

IEEE1588

The time is synchronized with a IEEE1588-compatible device (master) connected to an Ethernet network. Using IEEE1588 setup (IEEE1588 Setup), you can set the domain number and other parameters. This instrument can also be made the master (/C40 option). 10GBASE-R Ethernet (/C60 option) does not support IEEE1588.

Time Synchronization State

The time synchronization feature has the following three states.

 (Unlock)	The time is not synchronized.
 (Lock)	Time synchronization signal is being received correctly. When several minutes elapses after transiting to the Lock state, the instrument transits to the Stable state.
 (Stable)	The instrument's internal clock and the clock source are synchronized within 5 ppm.



Because the time synchronization signal is not received after waveform acquisition is started, wait for the time synchronization state to become Stable, and then start waveform acquisition.

IEEE1588 Setup (IEEE1588 Setup)

IEEE1588-compatible devices connected via Ethernet can be synchronized with the time sent from the master on the network. The master is automatically determined by priority and clock accuracy. The following settings become valid when time synchronization is IEEE1588.



- This instrument supports version IEEE1588-2008 (PTP v2).
 - For all devices on the network that need to be synchronized, set the following to the same settings. If the settings are different, the time cannot be synchronized.
Delay Mechanism, Network Layer, Domain Number
-

Transmission Delay Measurement Method (Delay Mechanism)

This instrument is fixed to End-to-End Mechanism (E2E).

Network Layer (Network Layer)

Select Layer2 or Layer3. Set this when synchronizing the time with an instrument whose network layer cannot be changed. Set the same settings for all devices that need to be synchronized.

Domain Number (Domain Number)

Assign a number of your choice to identify the device to be synchronized. Set the same settings for all devices that need to be synchronized.

Selectable range: 0 to 255. The default setting is 0.

Master Mode (Master Mode) (/C40 option)

Select whether to fix the device to slave or make it a master candidate.

- Slave Only: The instrument is fixed to slave.
- Master/Slave: Select this when you want to make the instrument a master. The priority comparison with the devices on the network determines whether this instrument becomes a master or a slave.

Master Time (Master Source) (/C40 option)

Select the time to use when this instrument becomes a master when the master mode is set to Master/Slave.

- Internal: The time of this instrument is used.
- GPS: Coordinated Universal Time received from a GPS satellite is used (/C35 option). A GPS unit (720940), sold separately, is required. If GPS is selected but the GPS signal reception is not stable, the instrument will not become the master.

Priority (Priority1/Priority2) (/C40 option)

Set the priority of this instrument when the master mode is Master/Slave.

The priority is compared with the devices on the network, and the device with the smallest number becomes the master. If the master cannot be determined by the priority of Priority 1, the priority is compared by the accuracy of the clock. If the master still cannot be decided, the master will be decided by the priority of Priority2.

Selectable range: 0 to 255. The default setting is 128.

Leap Second (Leap Second) (/C40 option)

When the master mode is set to Master/Slave, set the leap second to be transmitted through PTP when this instrument becomes the master. Turn off the time synchronization (Time Sync) temporarily before changing the leap second setting.

Selectable range: 0 to 255 (seconds). The default setting is 0.

IEEE1588 Information Monitoring (IEEE1588 Information)

You can monitor information related to IEEE 1588 time synchronization.

- **Master Clock ID**

Displays the master clock ID (64-bit identifier).

Display format: 16 characters (hexadecimal)

- **Local Clock ID**

Displays the local clock ID (64-bit identifier).

Display format: 16 characters (hexadecimal)

- **Port State**

Display the port status.

OFF	The IEEE 1588 time synchronization feature is off.
INITIALIZING, FAULTY, DISABLED, LISTENING, UNCALIBRATED, SLAVE	States defined in IEEE 1588-2008

- **Offset From Master**

Displays the offset from the master device.



- The time indicated by Offset From Master is based on values calculated from the packet timestamps, so it is an approximate value.
- Perform measurements after the master and sampling clock have become synchronized.
- To reset the IEEE1588 state or the sampling clock state, turn off the time synchronization feature temporarily, and specify IEEE1588 again.
- Usually, the sampling clock stabilizes about 2 minutes after Port State transitions to SLAVE. However, if the communication status with the master is poor or if the master clock is of low quality, the sampling clock may not be stable even when Port State is SLAVE.

IRIG Configuration (System Configuration)

You can specify the following IRIG settings. These become valid when time synchronization is IRIG.

IRIG Code Format (IRIG Format)

Set the IRIG code format to A or B.

IRIG Code Modulation Type (Modulation)

Set the IRIG modulation type to AM or Pulse-width Code (PWCode).

Input Impedance (Impedance)

Set the input impedance to 50 Ω or 5 k Ω .

22 Synchronizing Multiple Instruments (/C50 option)

You can connect up to five DL950s with optical fiber cords and synchronize their operation.

To perform synchronous operation, you need to configure one of the connected DL950s as a main unit and others as sub units.

For instructions on how to connect the instruments with optical fiber cords, see section 3.19 in the *Getting Started Guide*, IM DL950-03EN.

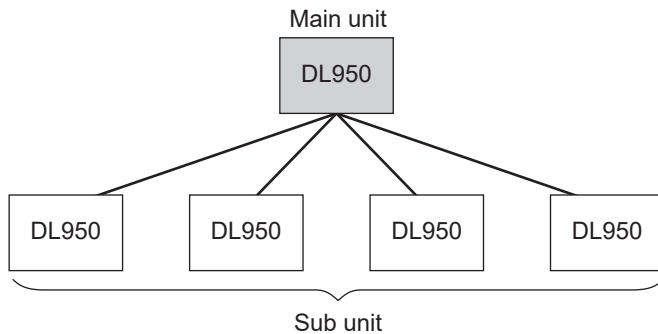

Multi-Unit Synchronization Setup (Multi Unit Sync.)

Multi-Unit Synchronization Mode (Mode)

Set the mode of each DL950 connected through optical fiber cords from the following.

- OFF: The multi-unit synchronization mode is turned off, and the instrument operates independently.
- Main Unit: Multi-unit synchronization mode is turned on, and the instrument becomes the main unit.
- Sub Unit: Multi-unit synchronization mode is turned on, and the instrument becomes a sub unit.



- The instruments must be connected in a star configuration with the main unit at the center. Synchronous operation is not possible if sub units are connected together.
- Set the multi-unit synchronization mode (Mode) properly on each DL950 connected in a star configuration. The multi-unit synchronization mode can be set to Main Unit only on the instrument connected to the sub units. Set the multi-unit synchronization mode to Sub Unit on all instruments connected to the main unit.
- Synchronous operation is not possible if the multi-unit synchronization mode is set to OFF on any of the connected DL950s.
- There are limitations to multi-unit synchronization mode connections depending on the version of each DL950 to be connected.

Connect (Connect)

The DL950s connected through optical fiber cords are connected in multi-unit synchronization mode.

- The multi-unit synchronization connection procedure starts when Connect (Connect) is executed on all DL950s (the main unit and sub units) to be connected.
- While the multi-unit synchronization connection procedure is in progress, the menu displayed on each DL950 shows Cancel (Cancel), which you can use to cancel the procedure.
- When a multi-unit synchronization connection is established, the menu display on each DL950 changes to Disconnect (Disconnect), and synchronous operation starts.
- If you execute Disconnect (Disconnect) on any of the synchronized DL950s, the other DL950s will enter standby mode, and the menu display changes to Cancel (Cancel). To reconnect, execute Connect (Connect) on the DL950 you disconnected.



- When using multi-unit synchronization, connect the main unit and all the sub units to be synchronized with optical fiber cords first and then execute the multi-unit synchronization connection procedure. The instrument may not operate properly if you insert or remove optical transceiver modules or optical fiber cords after executing the connection procedure.
- When a multi-unit synchronization connection is established, acquired history waveforms will be reset. Save all necessary history waveforms before making a multi-unit synchronization connection.
- If you turn off each DL950 with the multi-unit synchronization mode set properly, the multi-unit synchronization connection procedure will be executed automatically the next time you start each DL950. However, if the configuration of the connected DL950s is different from the previous time or if there is a DL950 with the multi-unit synchronization mode not set properly, the multi-unit synchronization connection procedure will not be completed. If this occurs, execute Cancel (Cancel) on all DL950s to cancel the multi-unit synchronization connection procedure, and redo the connection.
- If an error occurs in the power supply or connection during measurement in synchronous operation, all synchronized DL950s will enter standby mode, and you will not be able to change the settings or start measurements. To resume synchronous operation, execute Cancel (Cancel) on all DL950s, correct the error, and then redo the connection.

Notes on Synchronous Operation

Main Features and Operations during Synchronous Operation

During synchronous operation, the settings and operations of the main unit may or may not be synchronized with sub units.

The synchronized functions can be set or executed only on the main unit (operations on the sub units are invalid).

Functions that are not synchronized can be configured or executed independently on each unit.

The following table shows which functions are synchronized.

Function		Synchronization with the Main Unit	Notes
Operation mode	Scope mode, Recorder mode	Yes	
ACQUIRE	• Waveform acquisition settings • Time scale (Time/Div) ³ • Dual capture mode on and off ³	Yes	• The data save destination can be set separately when the acquisition method (Acquisition Method) is set to Memory + Save on Stop in Recorder mode. • The Single N trigger mode cannot be used. ³ • The Average acquisition mode cannot be used. ³
	START/STOP key execution	Yes	
TRIGGER	Trigger type (Type)	Yes	• In Scope mode, you can only use the simple trigger and OR of the enhanced trigger. • In Recorder mode, you can only use Edge, Time, and OR. You can use Time only on the main unit (Edge is displayed for the type on sub units, but it cannot be used).
	Trigger source	No	• You cannot use the trigger source line (Line). ³ • You can use the trigger source time (Time) ³ and external (External) only on the main unit.
	Unit setup	Yes	This item appears only on the setup menu of the main unit during synchronous operation.
	Time scale settings	Yes	Trigger position, hold-off, delay time, pre-trigger
	Vertical scale settings	No	Trigger level and other settings
VERTICAL	Channel setup	No	The record length and the number of history waveforms that can be set are determined by the number of channels of the unit with the highest number of channels in use.

22 Synchronizing Multiple Instruments (/C50 option)

Function		Synchronization with the Main Unit	Notes
RT.MATH CH ¹		No	
ANALYSIS ²	Power analysis, harmonic analysis	No	
MATH menu		No	
CURSOR menu		No	
FFT		No	
GO/NO-GO		—	Not available during synchronous operation.
ACTION		Yes	The data save destination and the email recipient (set with Network under Utility) can be set separately on each unit.
HISTORY ³		No	<ul style="list-style-type: none"> The display mode is fixed to one waveform on all units. History waveform searching is not available.
MEASURE menu		No	
ZOOM		No	Auto scrolling cannot be used during synchronous operation.
SEARCH		—	Cannot be used during synchronous operation.
DISPLAY menu		No	The accumulation display on/off setting and accumulation count are synchronized. ³
X-Y		No	
FILE menu	Save settings	Yes	<ul style="list-style-type: none"> The save destination and the traces to be saved can be set separately on each unit. Zoom cannot be specified for the waveform save range.
	Load settings	Yes	<ul style="list-style-type: none"> Waveform data and snapshots cannot be loaded. Setup files (excluding synchronized items) and symbol files can be loaded separately on each unit.
	Save/load execution	Yes	
IMAGE SAVE	Print settings	No	Comments are synchronized.
	Save settings	Yes	The save destination can be set separately on each unit.
	IMAGE/SAVE key execution	Yes	
SAVE	Save settings	Yes	The save destination can be set separately on each unit.
	SAVE key execution	Yes	
Time synchronization		No	Can be set only on the main unit.
Remote control		No	Remote control of synchronized settings is valid only on the main unit.
Ethernet Communication	TCP/IP 10G, TCP/IP	No	
	Communication function	No	FTP, Web server, email, network printer, network drive, Sntp
Other	Power-on action	—	Not available during synchronous operation.
	Remote stop	—	Not available during synchronous operation.

Yes: Sub units synchronize with the main unit.

No: Sub units do not synchronize with the main unit.

1 /G03, /G05 option

2 /G05 option

3 This is a setting available in Scope mode.



- For the trigger timing, the resolution is limited to 100 MHz. Therefore, even when the trigger source is set to a 200 M module (720212), a 10 ns trigger jitter will occur.
- Waveforms acquired by each synchronized DL950 can only be displayed on the DL950 that acquired the waveform. Therefore, analysis of acquired waveforms can be performed only on each DL950.

22 Synchronizing Multiple Instruments (/C50 option)

Options

If a multi-unit synchronization connection is made between DL950s with different options, the functions will be limited as follows.

Option	Limitations during Synchronous Operation
Memory	The record length and other settings are limited to match the model with the least memory among the standard model (no options), / M1 (4 G point memory expansion), and / M2 (8 Gpoint memory expansion).
Internal storage	SSD recording can be used only when all synchronized DL950s have the /ST1 option.
User-defined math function	The user-defined math function can only be used on DL950s with the /G02 option.
real time math function	The real time math function can only be used on DL950s with the /G03 or /G05 option.
Power math	The power math function can only be used on DL950s with the /G05 option.
IRIG and GPS interface	Time synchronization settings can only be set on the main unit. Sub units synchronize with the main unit. Time can be synchronized using IRIG or GPS when the main unit has the /C35 option.
IEEE1588 master feature	The IEEE1588 master function can only be used on the main unit with the /C40 option.

Saving Files

- You can set the save destination on each synchronized DL950. You can specify only the storage device (SD-1, USB-0/USB-1, Internal, Network) for the various file save destinations. You cannot specify a sub folder in a storage device.
- When you specify the storage destination device, a fixed area (Remote) is automatically created in its root directory.
- Files are saved in date_time folders created automatically in the fixed area. Usually, date folders are created at the action and SSD recording save destination, but in multi-unit synchronization mode, date_time folders are created in a fixed area.
- The following suffix is added to the end of the specified file name.
 - Main unit: _Main
 - Sub unit: _SubN (N = 1 to 4)

23 Other Features

Setup Data Store/Recall (Store/Recall)

You can save up to 17 sets of setup data in a reserved area of the internal memory. It is convenient to save setup data that you use frequently. Select the storage destination number from the following.

1 to 16, Product Setting*

* Product Setting allows you to also store and recall instrument-specific information such as Ethernet communication and environmental settings.

You can easily store and recall setup data simply by specifying this number.

You can recall setup data from the application menu.

▶ [See here.](#)

The common feature is the same as when saving waveform data.

▶ [See here.](#)

Calibration (CAL)

Performing a Calibration (Execute Calibration)

The vertical-axis ground level is calibrated. Perform a calibration when you want to make accurate measurements. Calibration is performed automatically when the power is turned on.

Notes about Calibration

- Allow the instrument to warm up for at least 30 minutes before you perform a calibration. If you perform a calibration immediately after power-on, the calibrated values may drift due to temperature changes or other environmental changes.
- Perform a calibration in a stable temperature environment ranging from 5 to 40 °C (23 ± 5 °C recommended).
- Do not apply signals when calibrating. Calibration may not be executed properly when input signals are being applied to the instrument.

Execute Power Integration Calibration

(Execute Calibration for Power Integ.)

This is a feature available on the /G05 option. ▶ [See here.](#)

Auto Calibration (Auto Calibration)

Turns auto calibration on and off. When auto calibration is turned on, auto calibration is executed when you start signal acquisition if any of the time periods listed below has elapsed since the power was turned on.

- Approx. 3 minutes
- Approx. 10 minutes
- Approx. 30 minutes and every 30 minutes thereafter

Power Integration Calibration (/G05 option)

The ground level of power analysis items is calibrated. Perform a calibration when you want to make accurate measurements. This calibration is not performed automatically. To make accurate power measurements, perform this calibration manually.

Notes about Calibration

- Allow the instrument to warm up for at least 30 minutes before you perform a calibration. If you perform a calibration immediately after power-on, the calibrated values may drift due to temperature changes or other environmental changes.
- Perform a calibration in a stable temperature environment ranging from 5 to 40 °C (23 ± 5 °C recommended).
- Do not apply signals when calibrating. Calibration may not be executed properly when input signals are being applied to the instrument.

Snapshot (SNAPSHOT)

Press this key to retain the currently displayed waveforms on the screen (snapshot waveforms). This is a useful feature when you want to compare waveforms because you can retain waveforms on the screen without stopping waveform acquisition.

Snapshot waveforms are displayed in white.

You cannot perform the following operations on snapshot waveforms.

Cursor measurement, automated measurement of waveform parameters, zoom, or computation

You can save and load snapshot waveforms.

Clear Trace (CLEAR TRACE)

Clears all the waveforms that are displayed on the screen.

If you change the display format or perform other similar operations, the instrument redisplay the channel waveforms, computed waveforms, and loaded waveforms that were displayed before you executed the clear trace operation.

Snapshot and clear trace features are disabled:

- When the instrument is in remote mode.
- When the instrument is printing, when it is executing auto setup, or when it is accessing a storage device.
- When GO/NO-GO determination is in progress, when action is in progress, or when searching is in progress.

Remote Control (Remote Ctrl)

This communication interface is used to control the instrument from a PC and to connect YOKOGAWA's Integrated Software (IS8000). For details see the *Communication Interface User's Manual*, IM DL950-17EN and the *Integrated Software User's Manual*, IM IS8000-01EN.



- "Remote" appears at the top of the screen when the instrument is communicating with a PC in remote mode. All keys except SHIFT + CLEAR TRACE are disabled in Remote mode.
 - The instrument keys are disabled while the PC's Integrated Software (IS8000) is connected to the instrument. If you want to control the instrument using its keys, on the PC, disconnect the Integrated Software (IS8000) from the instrument.
-

Types of Communication Interfaces (Device)

USB and Network are the available communication interfaces.

USB

When you connect this instrument to a PC via USB, the following settings are displayed.

- [USB Communication Function \(USB Function\)](#)

Network (Network)

When you connect this instrument to a PC via Ethernet, the following settings are displayed.

- [Timeout \(Time Out\)](#)
- [Interface \(Interface\)](#)



Do not use the two types of communication interfaces simultaneously. If you send commands simultaneously to them, the instrument will not execute the commands properly.

USB Communication Function (USB Function)

You can specify the communication features that are used when you connect the instrument to a PC through USB.

- TMC: You can use USB TMC (Test and Measurement Class) to control the instrument from a PC. If you want to connect the instrument to a PC through the USB port, install the YOKOGAWA USB TMC driver on your PC in advance. (Do not use USB TMC drivers (or software) supplied by other companies.)
- Storage: The connected PC can use the instrument as a USB storage device.
There is no need to install the USB TMC driver into your PC.



- For information about how to obtain the YOKOGAWA USB TMC driver (YTUSB), contact your nearest YOKOGAWA dealer. You can also access the YOKOGAWA USB driver download webpage and download the driver (<http://tmi.yokogawa.com/service-support/downloads/>).
 - When USB Function is set to Storage, only this instrument's internal SSD can be used as a storage device. You cannot access the storage device connected to the USB ports of the instrument.
 - When you access this instrument's internal SSD from a PC, only perform read and write operations. Otherwise, the instrument may malfunction.
 - When USB Function is set to Storage and files are being accessed, do not remove the USB cable or turn off the instrument. Doing so may cause a malfunction.
-

Timeout (Time Out)

If there is no access within a given time after starting the procedure to connect to the instrument through communication control, the instrument aborts the connection procedure.

Selectable range: 1 s to 3600 s, Infinite

Interface (Interface) (/C60 option)

Select the type of Ethernet to use in communication control.

- 1G: 1000BASE-T/100BASE-TX/10BASE-T Ethernet
- 10G: 10GBASE-R Ethernet (/C60 option)



- You must set TCP/IP parameters to connect this Instrument to an Ethernet network.
▶ [See here.](#)
 - When connecting this instrument to a PC via 1000BASE-T/100BASE-TX/10BASE-T Ethernet, be sure to use straight cables through a hub. Proper operation is not guaranteed for a one-to-one connection using a crossover cable.
 - For connections via 1000BASE-T/100BASE-TX/10BASE-TT Ethernet, use one of the following types of network cable that conforms to the transfer speed of your network.
A UTP (Unshielded Twisted-Pair) cable
An STP (Shielded Twisted-Pair) cable
 - When connecting this instrument to a PC via 10GBASE-R Ethernet (/C60 option), purchase an off-the-shelf optical transceiver module and optical fiber cords. For details, see section 3.19 in the *Getting Started Guide*, IM DL950-03EN.
-

System Configuration (System Config)

You can specify the following settings.

- [Date and Time Setting \(Date/Time\)](#)
- [Setting Time Synchronization \(Time Sync\)](#)
- [Language \(Language\)](#)
- [Setting the LCD \(LCD\)](#)
- [Formatting Storage Devices \(Storage Manager\)](#)
- [Update \(Update\)](#)

Date and Time Setting (Date/Time)

The instrument date and time.

Display ON/OFF (Display)

Set whether to display the date and time on the instrument screen.

Display Format (Format)

You can display the date in one of the following formats.

2021/02/01 (year/numeric month/day)

01/02/2021 (day/numeric month/year)

01-Feb-21 ([day]-[English abbreviation of the month]-[last two digits of the year])

01 Feb 2021 (day month (English abbreviation) year)

Date and Time Setting (Date/Time)

Sets the date and time.

Setting the Time Difference (Time Zone) from the Coordinated Universal Time (UTC)

Set the time difference between the region where you are using the instrument and the UTC.

Selectable range: Set the time difference in the range of -12 hours 00 minutes to 14 hours 59 minutes.

For example, Japan standard time is ahead of the UTC by 9 hours. In this case, set Hour to 9 and Minute to 00.

Checking the Time Difference from the Coordinated Universal Time (UTC)

Check using either of the following methods.

- Check the Date, Time, Language, and Regional Options on your PC.
- Check the website at the following URL: <http://www.worldtimeserver.com/>



-
- This instrument does not support Daylight Saving Time. To set the Daylight Savings Time, reset the time difference from Greenwich Mean Time.
 - Date and time settings are backed up using an internal lithium battery. They are retained even if the power is turned off.
 - This instrument manages leap-year information.
-

Language (Language)

You can set the following languages.

Setup Menu (Menu)

Set the language for displaying menu items.

Message (Message)

Set the language for displaying messages.

USB Keyboard (USB Keyboard)

Sets the USB keyboard language to English or Japanese. The USB keyboard can be used to enter file names, comments, etc.

Setting the LCD (LCD)

You can specify the following LCD settings.

Turning Off the LCD (LCD Turn OFF)

You can turn off the LCD. When the LCD is off, you can turn it back on by pressing a key.

Automatically Turning Off the LCD (Auto OFF)

The LCD turns off automatically when there are no key or touch panel operations for a given time period. The LCD turns back on when you press a key.

Auto Off Time (Auto OFF Time)

Set the time until the LCD turns off after the last panel key or touch panel operation for when the LCD auto-off feature is turned on.

Selectable range: 1 to 60 minutes

Adjusting the Brightness (Brightness)

You can adjust the brightness in the range of 1 (darkest) to 10 (brightest). You can prolong the LCD service life by decreasing the LCD brightness or by turning off the LCD when you do not need to view it.

Formatting Storage Devices (Storage Manager)

You can select the storage device to be formatted from the following options and format it.

- Internal SSD (/ST1 option)
- SD Memory Card



When you format a storage device, all the data on it is deleted.

Update (Update)

You can specify the following items.

Firmware (Firmware)

You can update the instrument's firmware.

To upgrade, save the latest firmware in the root directory of the USB memory, SD card, or the instrument's internal storage, insert the USB memory or SD card into the device, and then tap Execute (Execute).

The latest firmware can be downloaded from the firmware download page at the YOKOGAWA website (<http://tmi.yokogawa.com/service-support/downloads/>).

Entering License Keys for Options (Enter License Key for Option)

You can add the following options after purchasing this instrument. Install the options after you have purchased the license keys for them.

Available Options

/C40	IEEE1588 master feature
/G02	User-defined math function
/G05	Power math function (including real time math function)*
/VCE	Vehicle edition

* /G05 can be specified only on models with the /G03 (real time math) option.



The SUFFIX (suffix code) inscribed in the name plate on the instrument's case indicates the installed options at the time of factory shipment. After you add options through additional option licenses, check the options on the instrument overview screen.

Environment Settings (Preference)

Action Performed at Power On (Power On Action)

Setting Whether to Start Waveform Acquisition (Start)

Select whether to start waveform acquisition at power on (ON) or not (OFF).

Setting Whether to Turn the Action Function On or Off (Action)

Select whether to enable the action function at power on (ON) or not (OFF).

- ON: When the power is turned on, the action mode is set to the mode in use when the power was turned off.
- OFF: When the power is turned on, the action mode is off.

Startup Mode (Startup Mode)

Set how the instrument is to start when the main power switch is turned on.

- Standby Startup (Standby Startup): The instrument starts in standby mode when the main power switch is turned on. Run the instrument by pressing the power switch on the front panel.
- Immediate Startup (Immediate Startup): The instrument starts running when the main power switch is turned on.

Configuring the Logic Settings (Logic Setup)

Logic Channel Display Format (Numerical Format)

Choose whether to display the logic waveform values in the numeric monitor as binary (Bit) or hexadecimal (Hex) values.

Cursor Read Order (Cursor Order)

Choose the order that you want to read the bit data from logic input signals in.

- 1->8: Bit 1 to bit 8
- 8->1: Bit 8 to bit 1

Bit Data Display Order (Bit Order)

Choose the order that you want to display the bit data from logic input signals in.

- 1->8: Bit 1 to bit 8
- 8->1: Bit 8 to bit 1

Terminal Setup (Terminal Setup)

Enabling or Disabling the Remote High Edge (STOP) Signal (Remote Stop)

Select whether to enable (ON) the high edge (STOP) in the external start/stop remote signal or disable (OFF).

Trigger Output Signal (Trigger Out)

Select the type of signal to transmit from the trigger output terminal (TRIGGER OUT) from the following options.

- Normal (Normal)
A falling signal is transmitted when a trigger occurs.
- Pulse (Pulse)
A pulse signal is transmitted when a trigger occurs. You can set the pulse width.

Pulse Width (Pulse Width)

When you set the trigger output signal type to Pulse, you can set the pulse width to 1 ms, 50 ms, 100 ms, or 500 ms.

External Sample Output (External Sample Output)

Select the type of signal to transmit from the sample clock output terminal (CLKO) from the following options.

- OFF
Pulse signals are not output.
- Acquisition (Acquisition)
Pulse signals are output only while the instrument is acquiring waveforms. You can set the pulse rate.
- Free Run (Free Run)
Pulse signals are output at all times. You can set the pulse rate.

Pulse Rate (Pulse Rate)

If you set the external sample output type to a setting other than OFF, set the pulse rate.
Selectable range: 200 kHz to 5 Hz (in 1-2-5 steps)

Key/Knob Setup (Key/Knob Setup)

Turning On or Off the Click Sound (Click Sound)

You can turn on or off the click sound that is generated when you operate the jog shuttle.

START/STOP Key Response Time (START/STOP Response Time)

You can set the response time of the START/STOP key to instant (Quick) or 1 s or more (> 1sec).

Key Lock (Key Protect)

Sets the key lock target and key lock release method.

- Type (Type): Sets the target to apply a key lock when KEY PROTECT is pressed.
 - All (ALL): Key lock is applied to all keys and the LCD.
 - Except START/STOP (Except START/STOP): Key lock is not applied to the START/STOP key.
- Release Method (Release Type): Set the key lock release method.
 - Key (Key): The key lock is released by pressing the KEY PROTECT key.
 - Password (Password): The key lock is released by entering a password on the screen that appears by pressing the KEY PROTECT key.
- Password (Password)
Specify the password using up to eight alphanumeric characters. If you forget the password, you can release the key lock by turning on the instrument while holding down the RESET key. However, all settings will be initialized.

▶ [See here.](#)

Other Setup (Other Setup)

Beep on Error (Beep on Error)

- ON: A beep is generated when an error occurs.
- OFF: A beep is not generated even when an error occurs.

Touch Panel (Touch Panel)

Turns on or off the touch panel feature.

Self-test (SelfTest)

You can test the keyboard and memory operations. In addition, if necessary for information security control or other purpose, all deletable information in the instrument can be cleared.

Test Type (SelfTest)

You can perform the following tests.

Key Test (Keyboard)

Tests whether or not the front panel keys are operating correctly and whether or not the soft keyboard accepts input properly. The front panel keys are operating properly if the names of the keys that you press are highlighted. The soft keyboard is operating properly if you can enter the specified characters.

Memory Test (Memory)

Tests whether the internal memory is operating properly. If it is, "Pass" appears. If an error occurs, "Error" appears.

SD Memory Card Test (SD Card)

Tests whether the SD memory card is operating properly. If an error occurs, "Error" appears.

Internal SSD Test (SSD)

Tests whether the internal SSD is operating properly. If an error occurs, "Error" appears.

Execution (Test Exec)

Executes the selected item.

If an Error Occurs during a Self-Test

If an error occurs even after you carry out the following procedure, contact your nearest YOKOGAWA dealer.

- Execute the self-test again several times.
- Confirm whether or not the media being tested is properly inserted.

Overview (Overview)

You can display the following information about the instrument. The instrument numbers of the DL950 and each module are also displayed.

However, the instrument numbers of the following modules are not displayed.

701250, 701251, 701255, 701261, 701262, 701265, 701270, 701271, 701275, 720230, 720240

- Model: Model
- Memory Capacity (Record Length): Memory size (record length)
- Serial No: Instrument number
- MAC Address: A unique MAC address assigned to each instrument. This number is necessary for the purchase of additional options.
- Slot: Models and Instrument numbers of the inserted modules
- Options: Options
- Default Language: Default language
- Information: Displays the firmware version number (Firm Version), FPGA version number (FPGA Version), etc.



- 701265, 720266, 720221, 720240, and 720241 have a CPU and firmware in the module. For slots that have these modules installed in them, the version number of the firmware installed on the module is also displayed.

701265 or 720266

Example: 701265 A.AA

A.AA is the version of the firmware installed on the module.

720221, 720240, or 720241

Example: 720240 B.BB/C.CC

B.BB is the version of the firmware installed on the module. C.CC is the version of the firmware in the DL950 that can be installed. If the two above versions are the same, only one version number will be displayed.

- For the 701281, 720281, 720242, and 720243, the module version is displayed.

Example: 701281 0xAA

Key Lock (KEY PROTECT key)

You can lock the control keys and the LCD (touch panel) to prevent unintentional changes to the current state of the instrument. When the keys are locked, pressing any keys other than KEY PROTECT has no effect.

Operations are not allowed from the touch panel, USB mouse, or USB keyboard.

▶ [See here.](#)

Appendix

Appendix 1 How to Calculate the Area of a Waveform

Integ1TY

Sum of only the positive curve areas : $S_1 + S_2$

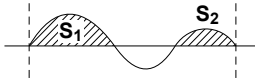

Integ2TY

Sum of the positive and negative curve areas: $S_1 + S_3 - S_2$

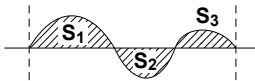

Integ1XY

(1) Multiple Loops

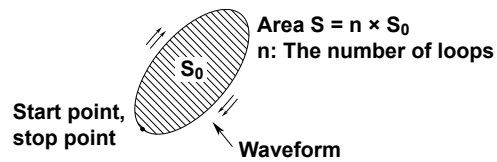

(2) Non-Closed Curve

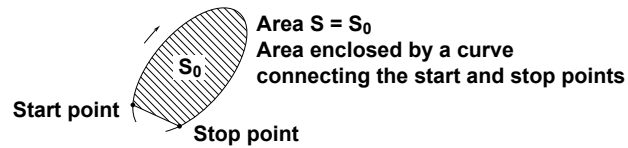

(3) Loop Tracing a Figure-Eight

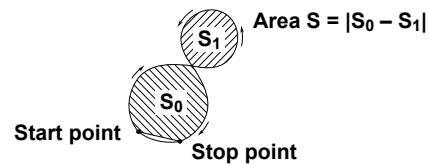

(4) Loop Tracing a Spiral

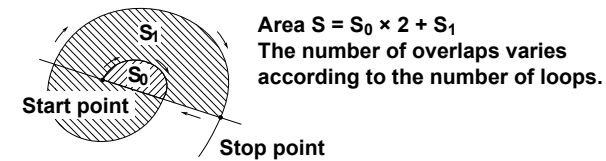

Integ2XY

(1) When Each Y Data Point Corresponds to a Single X Data Point

(1)

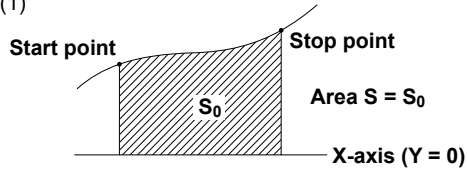

(2)

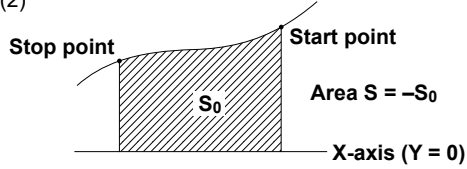

(3)

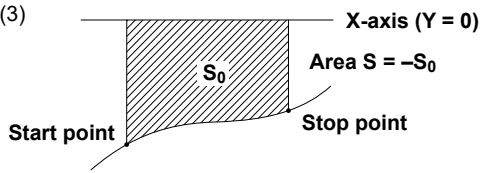

(4)

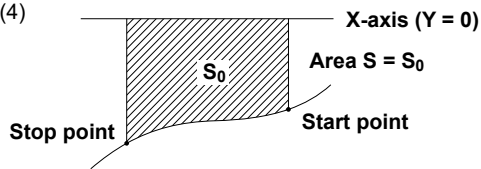

(2) When the Waveform Extends into the Negative Side

Start point

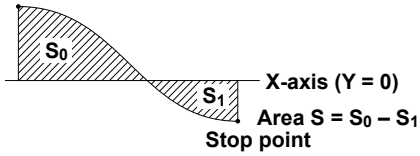

(3) When Multiple Y Data Corresponds to One Point of X Data

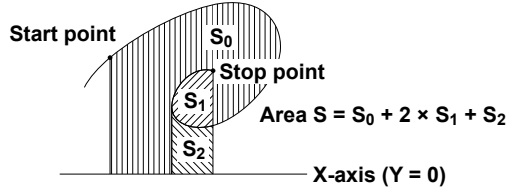
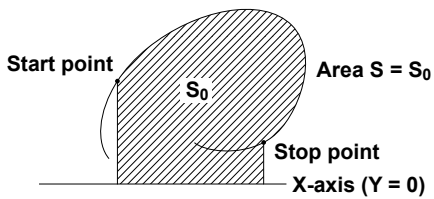

Appendix 2 User-Defined Math Function (/G02 option)

Digital Filter

Type

Type	Bandwidth
Gauss (Gauss)	Lowpass
Sharp (Sharp)	Lowpass, highpass, or bandpass
IIR (Butterworth)	Lowpass, highpass, or bandpass

Filter Order

See the following table for the filter orders.

		2 %	5 %	10 %	20 %	30 % (Cutoff*)
Gauss	Lowpass	49	21	9	5	5
Sharp	Lowpass	88	36	18	9	8
	Highpass	159	65	33	17	13
IIR	Lowpass	4	4	4	3	2
	Highpass	4	4	4	4	3

Filter Response

Filter	Passband Ripple	Attenuation Slope	Attenuation at the Stop-band	Phase
Gauss	0 dB	*	—	Linear phase
Sharp	±0.3 dB	-40 dB at 1 oct (Lowpass),	-40 dB	Linear phase
		-40 dB at -1 oct(Highpass)		
IIR	0 dB	-5 dB at 1/6 oct (Lowpass),	—	Non-linear phase
		-20 dB at -1 oct(Highpass)		

* Attenuation for Gauss: $-3.0 \times (f/f_c)^2$ dB(f: frequency, f_c : cutoff frequency)

Examples of Filter Frequency Responses

f: Sampling frequency (Hz)

Gauss (10 % cutoff)

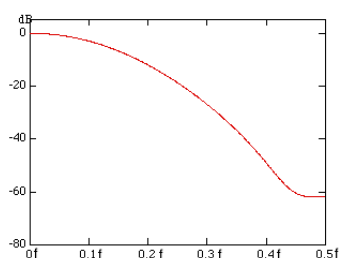

Sharp (low pass; 10 % cutoff)

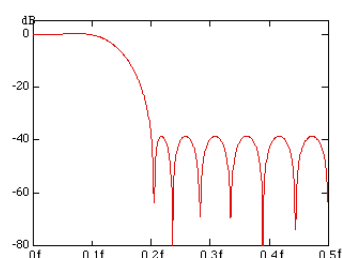

IIR (low pass; 10 % cutoff)

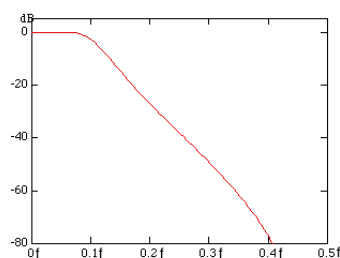

Computations take more time with higher filter orders.

Hilbert Function (HLBT)

Normally, when we analyze real-time signals, it is useful to think of these signals as the real part of functions of complex variables, and to carry out the actual signal analysis using such functions.

If the real-time signal is considered to be the real part of the function, the imaginary part can be determined with the Hilbert transform of the real part.

The Hilbert transform does not change the order of the individual variables. Hilbert transform of a time signal results in another time signal.

The Hilbert transform procedure is as follows.

When a time-domain signal is transformed, the signal is first transformed into the frequency domain through Fourier transform. Next, the phase of each frequency component is shifted by 90 degrees if the frequency is positive and +90 degrees if the frequency is negative. Lastly, taking the inverse Fourier transform completes the Hilbert transform.

Example

- The Hilbert transform can be used to analyze an envelope waveform.
 AM (amplitude modulation): $SQRT(C1 \times C1 + HLBT(C1) \times HLBT(C1))$
 Demodulation of an FM Signal: $DIF(PH(C1, HLBT(C1)))$

Phase Function (PH)

Phase function $PH(X1, Y1)$ computes $\tan^{-1}(X1/Y1)$.

The phase function takes the phase of the previous point into consideration and continues to sum even when the value exceeds $\pm\pi$ (the ATAN function reflects at $\pm\pi$).

The unit is radians.

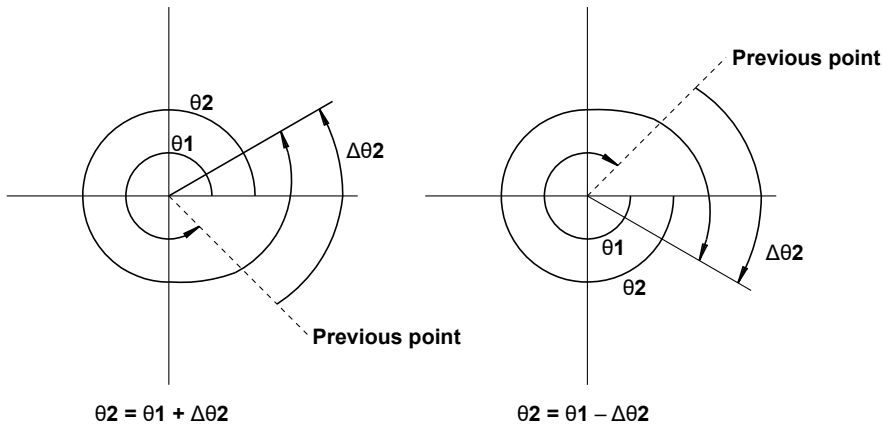

Differentiation and Integration (DIF, DDIF, INTG, IINTG)

Differentiation (DIF, DDIF)

The computation of the first-order and second-order differentiated values uses the 5th order Lagrange interpolation formula to derive a point of data from the five points of data before and after the target.

The figure below shows data f_0 to f_n with respect to sampling times x_0 to x_n . The derivative and integrated values corresponding to these data points are computed as shown below.

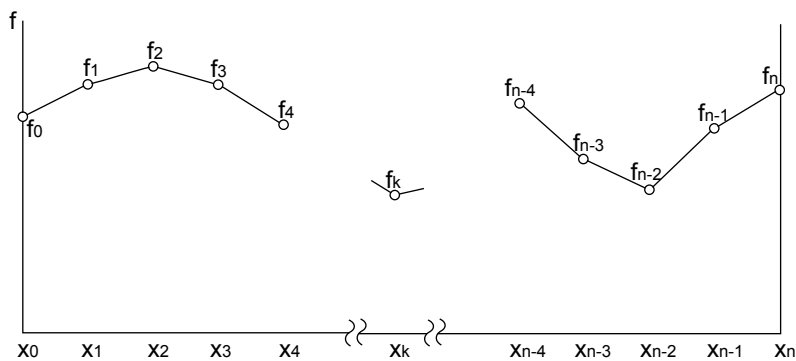

- Equations for First Order Derivatives (DIF)

$$\text{Point } x_0 \quad f_0' = \frac{1}{12h} [-25f_0 + 48f_1 - 36f_2 + 16f_3 - 3f_4]$$

$$\text{Point } x_1 \quad f_1' = \frac{1}{12h} [-3f_0 - 10f_1 + 18f_2 - 6f_3 + f_4]$$

$$\text{Point } x_2 \quad f_2' = \frac{1}{12h} [f_0 - 8f_1 + 8f_3 - f_4]$$

$$\text{Point } x_k \quad f_k' = \frac{1}{12h} [f_{k-2} - 8f_{k-1} + 8f_{k+1} - f_{k+2}]$$

$$\text{Point } x_{n-2} \quad f_{n-2}' = \frac{1}{12h} [f_{n-4} - 8f_{n-3} + 8f_{n-1} - f_n]$$

$$\text{Point } x_{n-1} \quad f_{n-1}' = \frac{1}{12h} [-f_{n-4} + 6f_{n-3} - 18f_{n-2} + 10f_{n-1} + 3f_n]$$

$$\text{Point } x_n \quad f_n' = \frac{1}{12h} [3f_{n-4} - 16f_{n-3} + 36f_{n-2} - 48f_{n-1} + 25f_n]$$

$h = \Delta x$ is the sampling interval (s) (example: $h = 200 \times 10^{-6}$ at 5 kHz)

- Equations for Second Order Derivatives (DDIF)

$$\text{Point } x_0 \quad f_0'' = \frac{1}{12h^2} [35f_0 - 104f_1 + 114f_2 - 56f_3 + 11f_4]$$

$$\text{Point } x_1 \quad f_1'' = \frac{1}{12h^2} [11f_0 - 20f_1 + 6f_2 + 4f_3 - f_4]$$

$$\text{Point } x_2 \quad f_2'' = \frac{1}{12h^2} [-f_0 + 16f_1 - 30f_2 + 16f_3 - f_4]$$

$$\text{Point } x_k \quad f_k'' = \frac{1}{12h^2} [-f_{k-2} + 16f_{k-1} - 30f_k + 16f_{k+1} - f_{k+2}]$$

$$\text{Point } x_{n-2} \quad f_{n-2}'' = \frac{1}{12h^2} [-f_{n-4} + 16f_{n-3} - 30f_{n-2} + 16f_{n-1} - f_n]$$

$$\text{Point } x_{n-1} \quad f_{n-1}'' = \frac{1}{12h^2} [-f_{n-4} + 4f_{n-3} + 6f_{n-2} - 20f_{n-1} + 11f_n]$$

$$\text{Point } x_n \quad f_n'' = \frac{1}{12h^2} [11f_{n-4} - 56f_{n-3} + 114f_{n-2} - 104f_{n-1} + 35f_n]$$

Integration (INTG, IINTG)

The first and second order integrated values are derived using the trapezoidal rule.

- Equations for First Order Integral (INTG)

Point $x_0 \quad l_0 = 0$

Point $x_1 \quad l_1 = \frac{1}{2} (f_0 + f_1)h$

Point $x_2 \quad l_2 = \frac{1}{2} (f_0 + f_1)h + \frac{1}{2} (f_1 + f_2)h = l_1 + \frac{1}{2}(f_1 + l_2)h$

Point $x_n \quad l_n = l_{n-1} + \frac{1}{2} (f_{n-1} + f_n)h$

- Equations for Second Order Integral (IINTG)

Point $x_0 \quad ll_0 = 0$

Point $x_1 \quad ll_1 = \frac{1}{2} (l_0 + l_1)h$

Point $x_2 \quad ll_2 = \frac{1}{2} (l_0 + l_1)h + \frac{1}{2} (l_1 + l_2)h = ll_1 + \frac{1}{2} (l_1 + l_2)h$

Point $x_n \quad ll_n = ll_{n-1} + \frac{1}{2} (l_{n-1} + l_n)h$

Binary Conversion(BIN)

Performs binary conversion using the specified threshold levels.

BIN(C1)

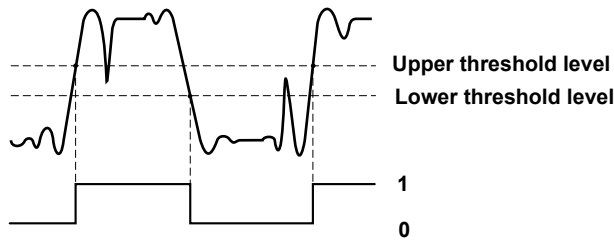

Pulse Width Computation

The signal is converted to binary values by comparing to the preset threshold level, and the time of the pulse width is plotted as the Y-axis value for that interval.

You can select one of the following intervals.

- PWHH From a rising edge to the next rising edge.
- PWHL From a rising edge to the next falling edge.
- PWLH From a falling edge to the next rising edge.
- PWLL From a falling edge to the next falling edge.
- PWXX From a rising or falling edge to the next rising or falling edge.
- FV Inverse of PWHH

Example for PWHH

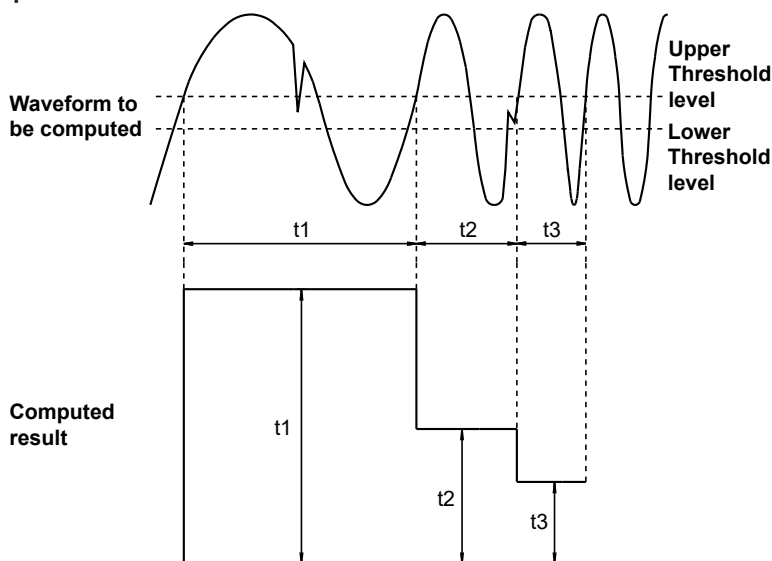

FFT Function - user-defined

Each frequency component G of a linear spectrum is represented by $G=R + jI$, where R is the real part and I is the imaginary part.

Linear Spectrum

The linear spectrum can be directly determined with the FFT. Through this spectrum, the magnitude and phase of each frequency component included in the measured waveform can be found. The power spectrum and cross spectrum can also be determined from one or two linear spectra.

Because the FFT is a complex function, the linear spectrum produces the real part and imaginary part of the frequency components. The magnitude and phase of the linear spectrum can also be determined from this result.

This instrument can determine the following spectra.

Item	Expression	Computation
Real part	LS-REAL	R
Imaginary part	LS-IMAG	I
Magnitude	LS-MAG	$\sqrt{(R^2 + I^2)}$
Log magnitude	LS-LOGMAG	$20 \times \log \sqrt{(R^2 + I^2)}$
Phase	LS-PHASE	$\tan^{-1}(I/R)$

Log magnitude reference (0 dB): 1 Vpeak

Appendix

RMS Spectrum

The RMS spectrum expresses the amplitudes of the linear spectrum with RMS values. It does not contain phase information.

This instrument can determine the following spectra.

Item	Expression	Computation
Magnitude	RS-MAG	$\sqrt{(R^2 + I^2)}/2$
Log magnitude	RS-LOGMAG	$20 \times \log \sqrt{(R^2 + I^2)}/2$

Log magnitude reference (0 dB): 1 Vrms

Power Spectrum

The power spectrum expresses the power (squared value) of each frequency component included in the measured signal. It is determined by taking the product of the linear spectrum and its complex conjugate. It does not contain phase information.

This instrument can determine the following spectra.

Item	Expression	Computation
Magnitude	PS-MAG	DC component $R^2 + I^2$ AC component $(R^2 + I^2)/2$
Log magnitude	PS-LOGMAG	DC component $10 \times \log(R^2 + I^2)$ AC component $10 \times \log\{(R^2 + I^2)/2\}$

Log magnitude reference (0 dB): 1 Vrms²

Power Spectrum Density

The power spectrum density expresses the power spectrum per unit frequency. It is determined by dividing the power spectrum by the frequency resolution Δf found during the analysis of the power spectrum. The computation varies depending on the window function.

Power spectrum density is used to compare power spectra analyzed at different frequency bands. However, it is not necessary for signals having a line spectrum such as sine waves.

This instrument can determine the following spectra.

Item	Expression	Computation
Magnitude	PSD-MAG	$PS-MAG / (\Delta f \times k)$
Log magnitude	PSD-LOGMAG	$10 \times \log PS-MAG / (\Delta f \times k)$

Log magnitude reference (0 dB): 1 Vrms²

Overall Value

The overall value is the total RMS value determined from the frequency spectrum included in the signal. The overall value is the square root of the summation of the power spectra of all frequencies.

$$\text{Overall value} = \sqrt{\frac{2 \times PS_0 + \sum PS_i}{k}} \quad (\text{Vrms})$$

“Rms = overall value” appears on the screen when automated measurement of waveform parameters is being performed (MEASURE is set to ON) on the channel that has been selected for power spectrum computation (PS or PSD) and Rms is set to ON.

However, when the time window is set to Exponential, overall values are not displayed.

k

k varies as indicated below depending on the selected time window.

Time Window Type	k
Rect (Rectangular window)	1
Hanning (Hanning window)	1.5
FlatTop (FlatTop window)	3.19693
Hamming (Hamming window)	1.3628

Cross Spectrum

The cross spectrum is determined from two signals. It is the product of the linear spectrum of one signal (G_y) and the complex conjugate (G_x^*) of the linear spectrum of the other signal (G_x).

If the linear spectra of the two signals are represented by

$$G_x = R_x + jI_x$$

$$G_y = R_y + jI_y$$

then the cross spectrum G_{yx} is

$$\begin{aligned} G_{yx} &= G_y \times G_x^* \\ &= (R_y + jI_y)(R_x - jI_x) = R_{yx} + jI_{yx} \end{aligned}$$

$$\text{where } R_{yx} = R_y R_x + I_y I_x$$

$$I_{yx} = R_x I_y - R_y I_x$$

This instrument can determine the following spectra.

Item	Expression	Computation
Real part	CS-REAL	$R_{yx}/2$
Imaginary part	CS-IMAG	$I_{yx}/2$
Magnitude	CS-MAG	$\sqrt{(R_{yx}^2 + I_{yx}^2)}/2$
Log magnitude	CS-LOGMAG	$10 \times \log(\sqrt{(R_{yx}^2 + I_{yx}^2)}/2)$
Phase	CS-PHASE	$\tan^{-1}(I_{yx}/R_{yx})$

Transfer Function

The transfer function expresses the frequency responses of the input to and the output from the transfer system. The transfer function is determined by the ratio of the output linear spectrum (G_y) and the input spectrum (G_x) at each frequency. Also, as can be seen from the following equation, the transfer function can be defined as the ratio of the cross spectrum of the input and output (G_{yx}) and the input power spectrum (G_{xx}).

$$\begin{aligned} \text{Transfer function} &= G_y/G_x = (G_y \times G_x^*)/(G_x \times G_x^*) = G_{yx}/G_{xx} \\ &= (R_{yx} + jI_{yx})/(R_x^2 + I_x^2) \end{aligned}$$

The instrument can determine the following items.

Item	Expression	Computation
Real part	TF-REAL	$R_{yx}/(R_x^2 + I_x^2)$
Imaginary part	TF-IMAG	$I_{yx}/(R_x^2 + I_x^2)$
Magnitude	TF-MAG	$\sqrt{(R_{yx}^2 + I_{yx}^2)}/(R_x^2 + I_x^2)$
Log magnitude	TF-LOGMAG	$20 \times \log(\sqrt{(R_{yx}^2 + I_{yx}^2)}/(R_x^2 + I_x^2))$
Phase	TF-PHASE	$\tan^{-1}(I_{yx}/R_{yx})$

The magnitude of the transfer function shows the ratio of the magnitudes of the output linear spectrum and the input linear spectrum while the phase shows the phase difference of the two.

Coherence Function

The coherence function expresses the ratio of the output power generated by the input signal to the transfer system and the total output power.

$$\text{Coherence function} = G_{yx} \times G_{yx}^*/(G_{xx} \times G_{yy})$$

Item	Expression	Computation
Phase	CH-MAG	$(R_{yx}^2 + I_{yx}^2)/(G_{xx} \times G_{yy})$

If the output signal is due entirely to the input signal, the coherence function becomes 1. As the ratio decreases, it falls below 1. Thus, the coherence function always takes on a value between 0 and 1.



On one data acquisition, the coherence function becomes 1 across all frequencies. Make sure to take the frequency average of the computation.

Time Windows

You can use a rectangular, Hanning, flattop, Hamming, or exponential window (you can use an exponential window on models only with the user-defined computation option).

The rectangular window is best suited to transient signals, such as impulse waves, which attenuate completely within the time window.

The Hanning, flattop, and Hamming windows allow continuity of the signal by gradually attenuating the parts of the signal located near the ends of the time window down to the 0 level. Hence, they are suited to continuous signals. The Hanning window provides a relatively higher frequency resolution compared to the flattop window. However, the flattop window has a higher level of accuracy. The Hamming window is a corrected Hanning window. The frequency resolution of its main beam is greater than that of the Hanning window. The Hamming window is suited for dividing close signals.

When the waveform being analyzed is a continuous signal, consider the above characteristics in selecting the proper window to be applied.

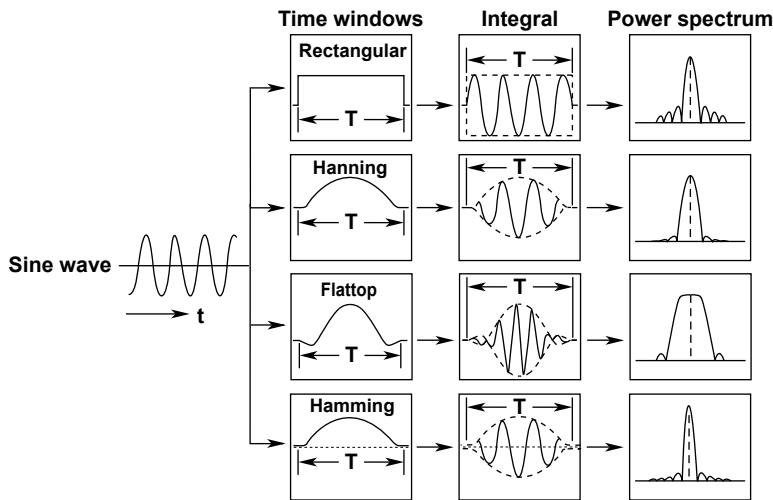

Rectangular: $W(t) = u(t) - u(t - T)$ $u(t)$: **Step function**
Hanning: $W(t) = 0.5 - 0.5 \cos(2\pi \frac{t}{T})$
Flattop: $W(t) = \{0.54 - 0.46 \cos(2\pi \frac{t}{T})\} \frac{\sin\{2\pi(1 - 2t/T)\}}{2\pi(1 - 2t/T)}$
Hamming: $W(t) = 0.54 - 0.46 \cos(2\pi \frac{t}{T})$

The exponential window is used to eliminate noise components from the signal. It is suited for the signals of impulse-excitation frequency-response tests and other similar signals. On this instrument, the exponential window and force window are activated simultaneously.

Exponential Window

The damping rate is set in terms of the weight of the last data point, with the weight of the first data point in the specified number of FFT points taken to be 100 % (= 1). You can set the damping rate in the range of 1 to 100 % (1 % resolution). The exponential window damps the signal exponentially along the time axis. It is effective when the signal does not attenuate fully within the record length. When the damping rate is set to 100 %, the window functions like a rectangular window.

Force Window

Set the area over which computation is performed in terms of a percentage from the first FFT point, taking the set number of FFT points to be 100 %. The areas (force 1 and force 2) can be set in the range of 1 to 100 % (1 % resolution) of the input/output signal. When an area is set to 100 %, the window functions like a rectangular window. On this instrument, the outer area is the average of the results of the window function for the data outside the area.

Force1: This setting applies to the input signals of one-waveform and two-waveform FFTs.

Force2: This setting applies to the output (response) signal (second parameter) of a two-waveform FFT.

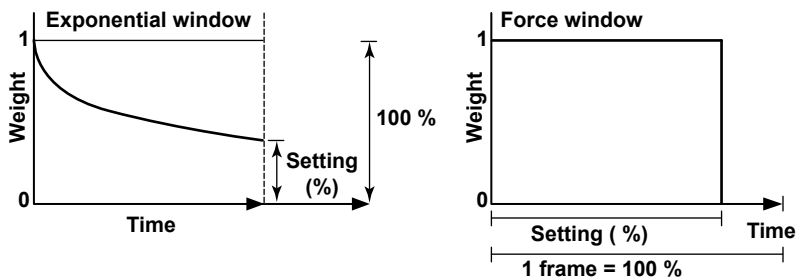

Combined Form of the Exponential and Force Windows

The instrument uses a window function that combines the exponential window and force window to perform computations. The outer area of the force window is the average of the results of the window function for the data outside the area.

When the Force Window Area Is Set to 80 % and the Data Outside the Area Is Taken into Account

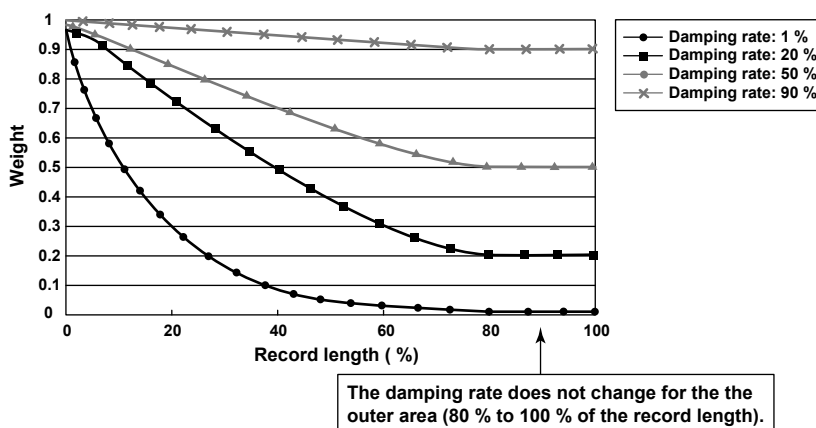

- Application Example on the Instrument

When the Damping Rate Is Set to 20 % and Force 1 Is Set to 80 %

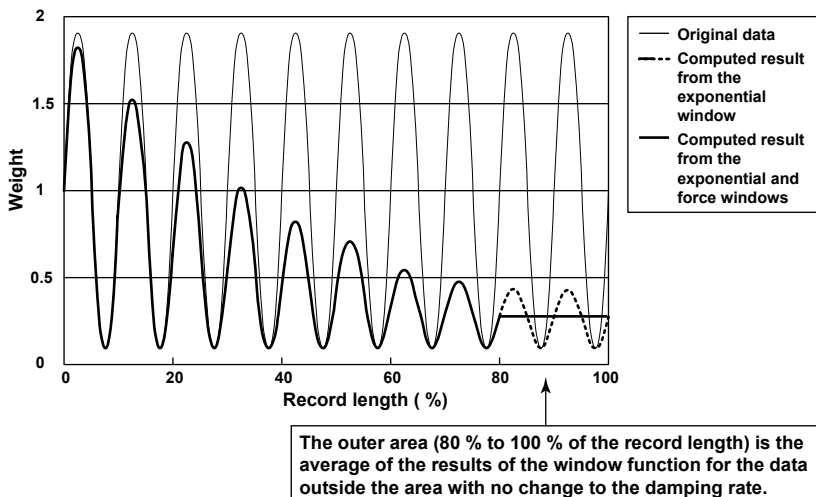

Notes When Executing the FFT Computation

Computation is normally performed on the sampled data in the acquisition memory. However, for waveforms that have been acquired in envelope mode, computation is performed on the maximum and minimum values per acquisition interval.

Appendix 3 ASCII Data File Format

The instrument can save waveform data to ASCII files. The format of such files is given below. The two sets of ASCII data are examples when the same waveform is saved with different waveform data save settings.

Waveform data save setup

- Time information: ON
- Different SampleRate: Space

	A	B	C
1	Header Size		15
2	Model Name	DL950	
3	Comment		
4	BlockNumber		1
5	TraceName	CH1_1	CH2_1
6	BlockSize	10001	1000
7	VUnit	V	V
8	SampleRate	200000	20000
9	HResolution	5.00E-06	5.00E-05
10	HOffset	-2.50E-02	-2.50E-02
11	HUnit	s	s
12	DisplayPointNo.	1	1
13	PhaseShift	1	1
14	Date	2020/10/16	2020/10/16
15	Time	27:11.7	27:11.7
16			
17		27:11.7 -2.49E+01	
18		27:11.7 -2.49E+01	
19		27:11.7 -2.49E+01	
20		27:11.7 -2.49E+01	
21		27:11.7 -2.49E+01	
22		27:11.7 -2.49E+01	
23		27:11.7 -2.49E+01	
24		27:11.7 -2.49E+01	-2.49E+01
25		27:11.7 -2.49E+01	
26		27:11.7 -2.49E+01	
27		27:11.7 -2.49E+01	
28		27:11.7 -2.49E+01	
29		27:11.7 -2.49E+01	
30		27:11.7 -2.49E+01	
31		27:11.7 -2.49E+01	
32		27:11.7 -2.49E+01	
33		27:11.7 -2.49E+01	
34		27:11.7 -2.49E+01	-2.49E+01
35		27:11.7 -2.49E+01	
36		27:11.7 -2.49E+01	

Time
information

1

3

2

Waveform data save setup

- Time information: OFF
- Different SampleRate: Supplement

	A	B	C
1	Header Size		15
2	Model Name	DL950	
3	Comment		
4	BlockNumber		1
5	TraceName	CH1_1	CH2_1
6	BlockSize	10001	10001
7	VUnit	V	V
8	SampleRate	200000	200000
9	HResolution	5.00E-06	5.00E-06
10	HOffset	-2.50E-02	-2.50E-02
11	HUnit	s	s
12	DisplayPointNo.	1	1
13	PhaseShift	1	1
14	Date	2020/10/16	2020/10/16
15	Time	27:11.7	27:11.7
16			
17		-2.49E+01	NAN
18		-2.49E+01	NAN
19		-2.49E+01	NAN
20		-2.49E+01	NAN
21		-2.49E+01	NAN
22		-2.49E+01	NAN
23		-2.49E+01	NAN
24		-2.49E+01	-2.49E+01
25		-2.49E+01	-2.49E+01
26		-2.49E+01	-2.49E+01
27		-2.49E+01	-2.49E+01
28		-2.49E+01	-2.49E+01
29		-2.49E+01	-2.49E+01
30		-2.49E+01	-2.49E+01
31		-2.49E+01	-2.49E+01
32		-2.49E+01	-2.49E+01
33		-2.49E+01	-2.49E+01
34		-2.49E+01	-2.49E+01
35		-2.49E+01	-2.49E+01
36		-2.49E+01	-2.49E+01

- 1 When the sample rate is different on each channel, sections where there is no waveform data become blank for waveforms acquired at slow sample rates.
- 2 When a blank section of the waveform acquired at a slow sample rate is interpolated using the previous data.
- 3 Not a number (NAN) is displayed in the section from the start of acquisition to the first sample data because there is no sampled data to be interpolated.

Header Size	The number of header lines.
Model Name	The model name.
Comment	Comment attached at the time the data file was saved.
BlockNumber	Block number for this group. When the block numbers vary depending on the waveform, this is the maximum block number.
TraceName	Name of each waveform.
BlockSize	The number of data points in one block for each waveform.
VUnit	Each waveform's Y-axis unit (this has no effect on the data).
SampleRate	The sample rate at the time of waveform acquisition.
HResolution	Each waveform's X-axis conversion coefficient, HResolution. $X\text{-axis value} = H\text{Resolution} \times (\text{Data No.} - 1) + H\text{Offset}$
HOffset	Each waveform's X-axis conversion coefficient, HOffset. $X\text{-axis value} = H\text{Resolution} \times (\text{Data No.} - 1) + H\text{Offset}$
HUnit	Each waveform's X-axis unit (this has no effect on the data).
DisplayBlockSize	The length of the data displayed on the screen (the display record length).
DisplayPointNo.	This number shows what point in memory is displayed on the left-most side of the display record length.
Date	Date of the time reference point*
Time	Time of the time reference point*

* For details on the time reference point, see chapter 4.

Appendix 4 Fundamental Equations for Defining Strain

Definition of Strain

$$\Delta L/L = \epsilon \dots\dots\dots(1)$$

ϵ : Strain
 L: Initial length of the material
 ΔL : Amount of change due to external strain

Definition of the Gauge Factor

Gauge factor (K) refers to the ratio between the mechanical strain and the change in the resistance of the strain gauge resistor.

$$\epsilon = \frac{\Delta L}{L} = \frac{\Delta R/R}{K} \dots\dots\dots(2)$$

$$(\Delta R/R) = K \times \epsilon \dots\dots\dots(3)$$

R: Gauge resistance
 ΔR : Amount of change in resistance when strain is applied

Normally, K = 2.0. However, the value varies depending on the strain gauge material.

General Equation for the Measured Voltage (V) and Strain (ϵ) of a Wheatstone Bridge (1 Gauge Method)

If we assume V to be the voltage measured on the bridge and E to be the voltage applied to the bridge,

$$V = (1/4) \times E \times (\Delta R/R) \dots\dots\dots(4)$$

From equation (3),

$$(\Delta R/R) = K \times \epsilon$$

$$\text{Thus, } V = (1/4) \times E \times K \times \epsilon \dots\dots\dots(5)$$

When Determining the Strain (ϵ) from the Measured Voltage (V) (Using a Strain Gauge and the 1 Gauge Method)

If we derive ϵ from equation (5)

$$\epsilon = (4/K) \times (V/E) \dots\dots\dots(6)$$

When Determining the Measured Value of the Strain Gauge Sensor (e) from the Voltage Measured on the Bridge (V) (Strain Gauge Sensor)

Assuming e to be the measured value (measured value of the strain gauge sensor: mV/V unit) and substituting $\epsilon = e$ in equation (6),

$$e = (4/K) \times (V/E) \dots\dots\dots(7)$$

In the case of a strain gauge sensor, set the gauge factor (K) to 2 on the instrument. If you change the value of K, the values are converted through the use of the above equation.

Appendix 5 Strain Shunt Calibration

Shunt calibration adjusts the strain measurement gain through the connection in parallel of a known resistance (the resistance for shunt calibration, hereinafter referred to as the shunt resistance) to the strain gauge. The strain module (701271 (STRAIN_DSUB)) supports shunt calibration with a built-in shunt-calibration relay circuit. To perform a shunt calibration, you need a bridgehead (701957/701958) that supports shunt calibration.

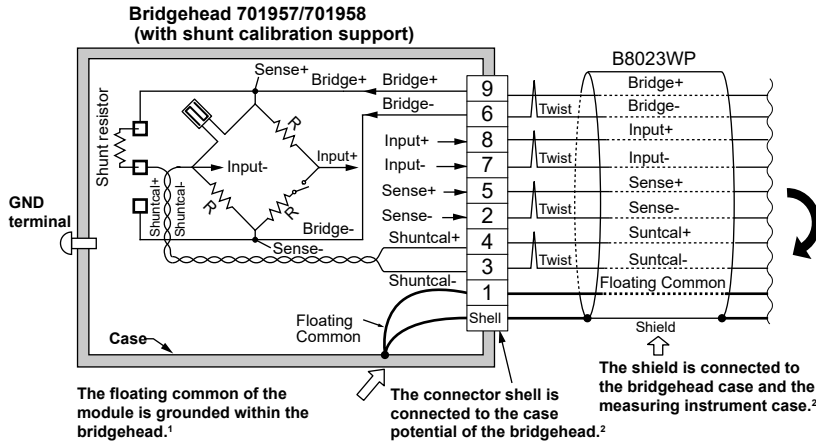

- 1 The GND (floating common) of the module is connected to the case potential inside the bridge box.
- 2 The bridgehead case, the cable shield, and the measuring instrument case are connected as measures against noise.

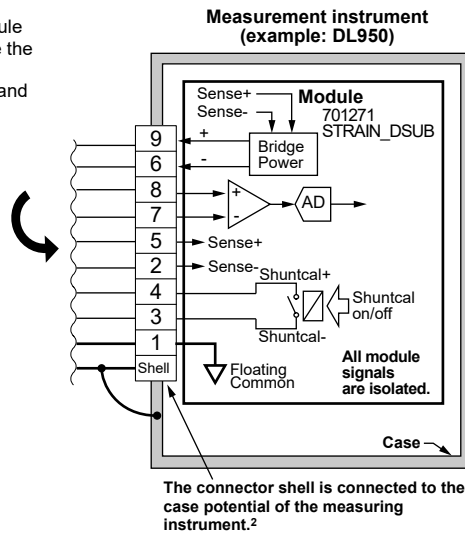

- When correcting the gain on the negative side (normal)

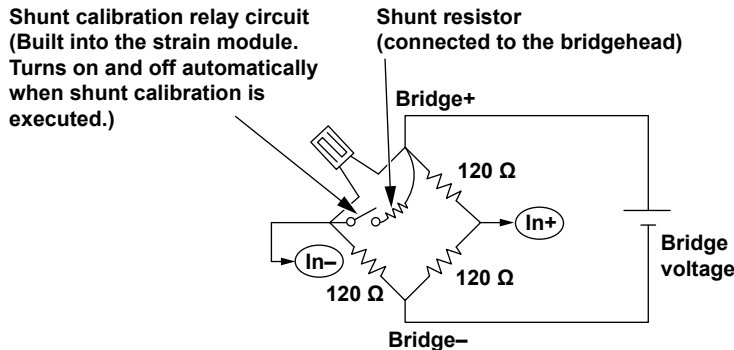

- When correcting the gain on the positive side

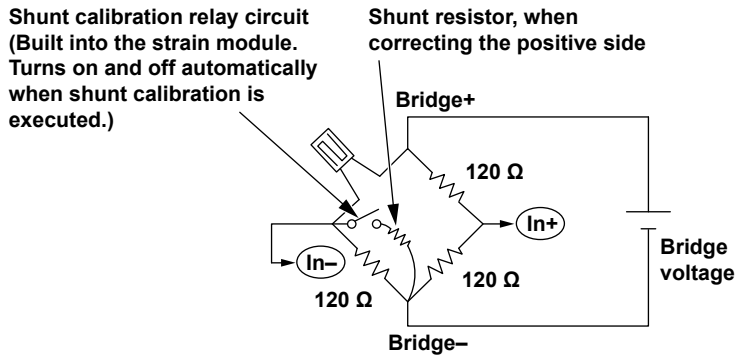

Shunt Calibration Procedure

1. Calculate the strain value (μSTR) that corresponds to the shunt resistor you will use. For the calculation procedure, see “Calculating the Shunt Resistance” in the next section.
2. Execute balancing without applying a load to the strain gauge, and correct the zero point.
3. Perform a shunt calibration, and correct the gain.

To perform a shunt calibration, from the instrument’s CH menu, select Linear Scale, Mode, and then Shunt. Usually, the negative gain is corrected. However, if you are correcting the positive gain, change the position of the shunt resistor as shown in the above figure.

- Balance

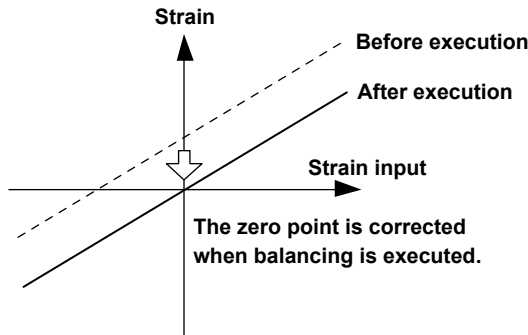

- Shunt calibration

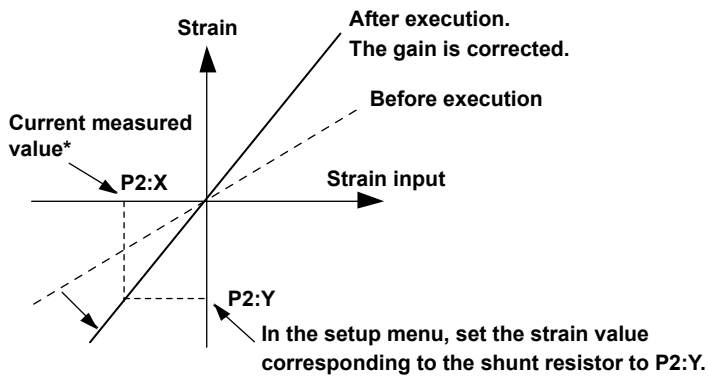

* Obtained automatically when shunt calibration is performed

Shunt Calibration Execution Menu

The shunt calibration execution menu appears when from the CH menu, you select Linear Scale, Mode, and then Shunt. In normal shunt calibration, you only need to set P2[Y]. On the instrument, in addition to performing normal shunt calibration (when the shunt-calibration relay circuit is on), you can also set the zero-point value when the relay circuit is off. The zero-point value is valid when the strain value after balancing is performed is not 0.

Items in the Execution Menu

- (1) P1[X]: When a shunt calibration is execute, the input value when the relay circuit is off is applied.
- (2) P1[Y]: Set the value for when the relay circuit is off (normally 0).
- (3) P2[X]: When a shunt calibration is executed, the input value when the relay circuit is on is applied.
- (4) P2[Y]: Set the strain value that corresponds to the shunt resistance when the relay circuit is on.



- When you perform a shunt calibration, select an appropriate range so that the measured values will stay within the range when the shunt-calibration relay circuit is on. The instrument attempts to perform a shunt calibration within the current range.
- An error message will appear if shunt calibration fails (because of out-of-range values or some other reason). When this happens, change the range, and perform a shunt calibration again.

Reducing Noise

Because measurements are made at the mV level, the strain gauge is extremely susceptible to noise. If the execution of balancing or shunt calibration fails, it may be due to noise. Please take the following points into consideration.

- Because the strain gauge is attached away from the bridgehead, we recommend that you use twisted wire for extensions.
- Use a bridgehead with high noise resistance. We recommended that you use a YOKOGAWA bridgehead (701957 or 701958); they are highly resistant to noise.

Calculation of the Shunt Resistance

To perform a shunt calibration, you need to calculate the shunt resistance (Rs) and the expected strain (ε) in advance. For “P2-Y,” use ε as given in the equation below (normally a negative value).

In the general method given for shunt calibration (the easy method), an error of 1 to 2 % is introduced as the strain value (ε) increases. Therefore, use the detailed method whenever possible.

Equation for Rs and ε When Shunt Calibration Is Executed

General Equation (Easy method)

$\Delta R/R = K \times \epsilon$ (1): Fundamental strain equation

$\Delta R = R - R/Rs^*$ (2): Equation for the change in resistance when the shunt resistance is on

* In this manual, the equation for parallel resistances is expressed as follows:

$$R/Rs = \frac{1}{\frac{1}{R} + \frac{1}{Rs}} = \frac{R \times Rs}{R + Rs}$$

If ΔR from (1) and (2) is canceled out,

$Rs = R \times (1 - K \times \epsilon) / (K \times \epsilon)$
Equation A: General equation for calculating the shunt resistance (includes error)

- ε: Strain (strain value that you want to be generated when the shunt resistance is turned on)
- K: Gauge factor
- R: Bridge resistance
- ΔR: Resistance change
- Rs: Shunt resistance (shunt resistance you want to derive)

Detailed Equation

$V_0 = E \times (R_1 \times R_3 - R_2 \times R_4) / \{(R_1 + R_2) \times (R_3 + R_4)\}$
 (1) Basic equation for a Wheatstone bridge

When shunt calibration is on,

$V_0 = E \times (R_1 \times R_3 - R' \times R_4) / \{(R_1 + R') \times (R_3 + R_4)\}$
 (2): Equation when shunt calibration is on

$R' = R_2 // Rs$ (3): Equation for combined resistance R'

$R_1 = R_2 = R_3 = R_4 = R$ (4): Since R₁ to R₄ are equal, they are represented as R.

Also, from the basic equation of strain,

$V_0/E = K \times \epsilon / 4$ (5): Basic equation of strain

If V₀/E and R₁ to R₄ from (2), (3), (4), and (5) are canceled out,

$Rs = R \times (1 - K \times \epsilon / 2) / (K \times \epsilon)$
Equation B: Detailed equation for calculating the shunt resistance (no error)

- E: Bridge voltage
- V₀: Bridge output voltage
- R₁ to R₄: Bridge resistance (where R₁ = R₂ = R₃ = R₄)
- Rs: Shunt resistance (shunt resistance you want to derive)
- R': Combined resistance when the relay is turned on (R' = R//Rs)

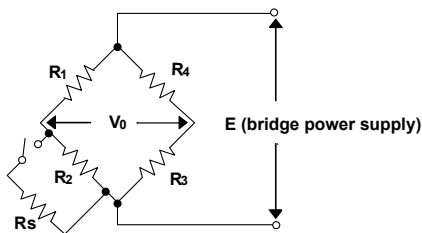

Calculation Example

When Determining the Shunt Resistance (Rs) from the Strain (ϵ)

Given a gauge factor (K) of 2,

Detailed equation (equation B) $R_s = R \times (1-\epsilon)/(2 \times \epsilon)$ (6)

General equation (equation A) $R_s = R \times (1-2 \times \epsilon)/(2 \times \epsilon)$ (7) Degree of error of 1 to 2 %

Desired Strain ϵ (μ STR)	Rs Value (Ω) Derived from the Detailed Equation (6)		Rs Value (Ω) Derived from the General Equation (7)	
	R = 120 Ω	R = 350 Ω	R = 120 Ω	R = 350 Ω
1,000	59,940	174,825	59,880	174,650
2,000	29,940	87,325	29,880	87,150
5,000	11,940	34,825	11,880	34,650
10,000	5,940	17,325	5,880	17,150

When Determining the Strain (ϵ) from the Shunt Resistance (Rs)

If we derive ϵ from equations (6) and (7),

Detailed equation (equation B) $\epsilon = 1/(1+2 \times R_s/R)$ (8)

General equation (equation A) $\epsilon = 1/\{2 \times (1+R_s/R)\}$ (9) Degree of error of 1 to 2 %

- When the Bridge Resistance R is 120 Ω

RS Value (Ω)	Strain ϵ (μ STR) Derived from the Detailed Equation (8)	Strain ϵ (μ STR) Derived from the General Equation (9)
60,000	999	998
30,000	1,996	1,992
12,000	4,975	4,950
6,000	9,901	9,804

- When the Bridge Resistance R is 350 Ω

RS Value (Ω)	Strain ϵ (μ STR) Derived from the Detailed Equation (8)	Strain ϵ (μ STR) Derived from the General Equation (9)
180,000	971	970
90,000	1,941	1,937
36,000	4,838	4,814
18,000	9,629	9,537

Appendix 6 Frequency Module's Math Expression and Smoothing Filter's Filter Response

Computation Format (Resolution) of the Frequency Module

The computation flow on the frequency module is indicated below.

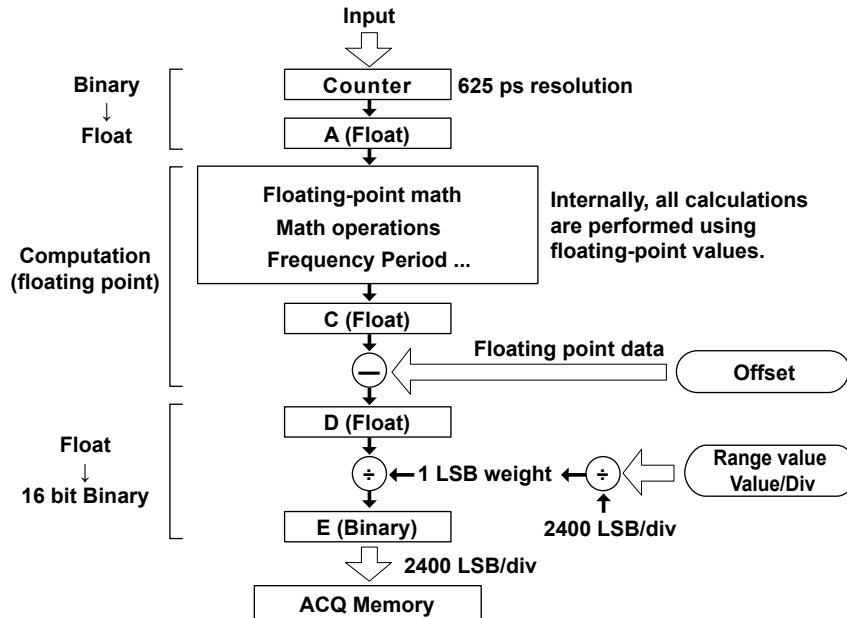

The frequency module measures the period of the input signal at a resolution of 625 ps. Therefore, the minimum resolution is 625 ps. Computations are performed in floating point format. The data that is output from the frequency module and written to the acquisition memory (ACQ Memory) is 16-bit binary data. The frequency module converts the data using a weight of 1 LSB that is determined by Value/div. The data is normalized to 2400 LSB/div when displayed on the screen.

Input: Conversion from Counter Values to Floating Point Values

The frequency module converts the count value that it obtains at 625 ps resolution to floating point format, and determines period A using the following equation.

$$\text{Period A (Float)} = (\text{Count value}) \times 625 \text{ ps}$$

Math

Various computations are performed in floating point format based on the settings.

Example: Frequency: $C (\text{float}) = 1/A (\text{float})$

Calculation of the 1 LSB Weight of the Output

The 1 LSB weight of the output is determined from the range (value/div).

Because 1 div = 2400 LSB,

$$1 \text{ LSB weight of the output} = (\text{Value/div})/2400$$

Computation Output: Conversion from Floating Point Values to 16-bit Binary Values (When the Offset Is 0)

When the offset value is 0, offset calculation is not performed, and $C (\text{float}) = D (\text{float})$.

The data is converted into 16-bit binary data and written to the acquisition memory (ACQ Memory).

$$16\text{-bit binary data: } E (\text{binary}) = D (\text{float}) \div (1 \text{ LSB weight of the output})$$

Offset Computation

When the offset value is not 0, the frequency module computes the offset value in floating point format using the following equation and then converts the value to 16-bit binary data.

$$D (\text{float}) = C (\text{float}) - \text{offset value (float)}$$

In offset computation, if the computed result $C (\text{float})$ is equal to the offset value, the output is 0. If the computed result $C (\text{float})$ is less than the offset value, $E (\text{binary})$ is negative.

Filter Characteristics (Time Delay) of the Smoothing Filter

The smoothing filter is a moving average filter in which computation is performed in real time. The smoothing filter takes the simple average of the data whose data update rate is 1 μs (1 MHz) over 40 μs and performs moving average at 40 μs intervals. The computation interval of moving average is constant, independent of the instrument's sample rate. The data computed at 40 μs intervals is linearly interpolated to 1 μs data and transmitted.

The moving average order (the number of averaged points) is specified in terms of time. The maximum value is 25000 points (when the time is set to 1000 ms).

The characteristics of the smoothing filter are as follows:

- The filter is a low-pass filter.
- The pass band is flat.
- The filter has linear phase characteristics. The group delay is constant for a given filter order.

The group delay can be derived through the following equation.

$$\text{Group delay} = (\text{the number of moving-averaged points} - 1) \times 40 \mu\text{s}/2$$

- The filter has comb-shaped bandwidth characteristics.

The figure below shows the result of applying the smoothing filter to a waveform that changes in steps. The smoothing filter setup time follows the step change.

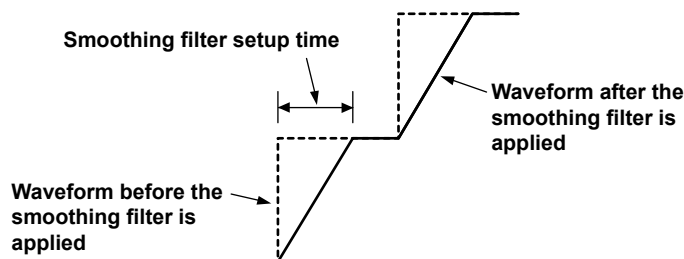

Appendix 7 List of Preset Settings of the Frequency Module

Logic 5V

Setup Item	Setting
V Range	±10 V
Coupling	DC
Probe	Yes ¹
bandwidth	Yes ²
Threshold	2.5 V
Hys	Yes ³
slope	Yes ⁴
Chattering Suppression	Yes ⁵
Pull Up	No

Logic 3V

Setup Item	Setting
V Range	±5 V (Probe = 1:1) ±10 V (Probe = 10:1)
Coupling	DC
Probe	Yes ¹
bandwidth	Yes ²
Threshold	1.5 V
Hys	Yes ³
slope	Yes ⁴
Chattering Suppression	Yes ⁵
Pull Up	No

Logic 12V

Setup Item	Setting
V Range	±20 V
Coupling	DC
Probe	Yes ¹
bandwidth	Yes ²
Threshold	6 V
Hys	Yes ³
slope	Yes ⁴
Chattering Suppression	Yes ⁵
Pull Up	No

Logic 24V

Setup Item	Setting
V Range	±50 V
Coupling	DC
Probe	Yes ¹
bandwidth	Yes ²
Threshold	12 V
Hys	Yes ³
slope	Yes ⁴
Chattering Suppression	Yes ⁵
Pull Up	No

Pull-up 5V

Setup Item	Setting
V Range	±10 V
Coupling	DC
Probe	1:1
bandwidth	Yes ²
Threshold	2.5 V
Hys	Yes ³
slope	Yes ⁴
Chattering Suppression	Yes ⁵
Pull Up	Yes ⁶

ZeroCross

Setup Item	Setting
V Range	Yes ⁷
Coupling	AC:
Probe	Yes ¹
bandwidth	Yes ²
Threshold	0 V
Hys	Yes ³
slope	Rising
Chattering Suppression	Yes ⁵
Pull Up	No

AC100V

Setup Item	Setting
V Range	±200 V
Coupling	AC:
Probe	10:1
bandwidth	Yes ² (Full cannot be selected)
Threshold	0 V
Hys	Yes ³
slope	Rising
Chattering Suppression	Yes ⁵
Pull Up	No

AC200V

Setup Item	Setting
V Range	±500 V
Coupling	AC:
Probe	10:1
bandwidth	Yes ² (Full cannot be selected)
Threshold	0 V
Hys	Yes ³
slope	Rising
Chattering Suppression	Yes ⁵
Pull Up	No

EM Pickup

Setup Item	Setting
V Range	±1 V
Coupling	DC
Probe	1:1
bandwidth	Yes ²
Threshold	0 V
Hys	Yes ³
slope	Rising
Chattering Suppression	Yes ⁵
Pull Up	No

User

Setup Item	Setting
V Range	Yes ⁷
Coupling	Yes ⁸
Probe	Yes ¹
bandwidth	Yes ²
Threshold	Yes ⁹
Hys	Yes ³
slope	Yes ⁴
Chattering Suppression	Yes ⁵
Pull Up	No

When you select a preset, the setup items are automatically set to the values in the table. The meaning of Yes and No in the table is as follows:

Yes: The setting can be configured.

No: The setting cannot be configured (it does not appear on the menu).

- 1 Set the probe type to 1:1 or 10:1.
- 2 Set the bandwidth limit to 100 Hz, 1 kHz, 10 kHz, 100 kHz, or Full. You cannot select full for AC100 V or AC200 V.
- 3 Set the hysteresis to $\pm 1\%$, $\pm 2.5\%$, or $\pm 5\%$.
- 4 Set the slope to rising or falling.
- 5 Set the chattering elimination value to a value from 0 ms to 1000 ms.
- 6 Enable or disable the pull-up. This setting is available only for Pull-up 5 V.
- 7 Voltage ranges:
When probe = 1:1, select ± 1 V, ± 2 V, ± 5 V, ± 10 V, ± 20 V, or ± 50 V.
When probe = 10:1, select ± 10 V, ± 20 V, ± 50 V, ± 100 V, ± 200 V, or ± 500 V.
- 8 Set the coupling to DC or AC.
- 9 Set the threshold level to a value within the specified voltage range.

Appendix 8 TCP and UDP Port Numbers

The TCP and UDP port numbers that are used on the Ethernet interface of the instrument are listed below.

TCP Port Numbers

Port Number	Description	Used For
20	File Transfer [Default Data]	FTP server, FTP client* and a portion of the Web server
21	File Transfer [Control]	FTP server, FTP client, and a portion of the Web server
25	Simple Mail Transfer Protocol	SMTP client
80	World Wide Web HTTP	Web server and WebDAV server
515	—	LPR client
111		
1024	—	Instrument control through the Ethernet interface
1025		
10002 (send)		

UDP Port Numbers

Port Number	Description	Used For
67	Bootstrap Protocol Server	DHCP client
68	Bootstrap Protocol Client	(listen port)
123	Network Time Protocol	SNTP client

- * The port number when FTP passive mode is disabled. When FTP passive mode is enabled, you can set any port number. When FTP passive mode is disabled, connections are established from the server. If you are connecting the instrument from behind a firewall, enable FTP passive mode.

Appendix 9 Firmware Version and New Features

This manual covers firmware versions 1.00 or later of this instrument. The following table contains new features that are available for each firmware version. If you are using an older version, you will not be able to use all the features described in this manual. To view the firmware version, press UTILITY and then the Overview soft key, and check Firm Version on the Overview screen that is displayed.

Version	Suffix Code	New Features
1.00 and later	Standard	-

Appendix 10 Using Data Files (WDF Files)

- To use the data in binary data files generated by the instrument on a PC, use the “WDF File Access Library” provided by YOKOGAWA.
- To convert data into YOKOGAWA’s legacy file format (*.WVF + *.HDR), use the “Binary Data File Converter” provided by YOKOGAWA.
- To view the data in WDF files without using the “WDF File Access Library,” refer to the following information.



This information does not apply to files created using SSD recording of this instrument or free-run recording of YOKOGAWA’s Integrated Software (IS8000). To use the data in these types of files, use the “WDF File Access Library” provided by YOKOGAWA.

Information for Viewing Data in WDF Files

WDF File Structure

A WDF file is made up of a common header block and blocks of data organized by type, which are referred to as *chunks*. Chunks are analogous to boxes that data is placed in. Multiple chunks are strung together to form a single WDF file. A special chunk called “FeND chunk” that contains no data always appears at the end of a file (except for waveform files divided into multiple files).

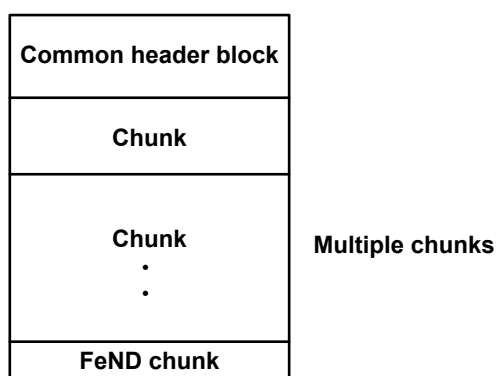

Common header block

The main role of the common header block is to indicate that the file is a WDF waveform file. An identifier is contained in the first four bytes. The next four bytes indicate the size of the common header. The rest of the common header block is undisclosed.

offset	Type	Identifier	byte	Description
0x0000	CHR	FileID	4	“%WDF”
0x0004	UINT	Length	4	Common header size
0x000C	-	Data	-	Undisclosed

Chunk

Chunks are structured like boxes that hold data. A chunk consists of a unique name (four characters long), data size, data, and end marker. The data size indicates the size of the stored raw data; it does not include the size of the chunk name, the value field (which indicates the data size) or the end marker. The total chunk size is raw data + 16 bytes. To use the information in a WDF file, there is no need to read the raw data in every chunk; the chunks in the file can be scanned or skipped until the appropriate one is found.

offset	Type	Identifier	byte	Description
0x0000	CHR	ChunkType	4	Chunk name string
0x0004	UINT64	Length	8	Data size in chunk
0x000C	-	Data	-	Raw data (data size in length)
	UINT	EndMark	4	0xffffffff or the data's CRC32 value

Waveform Analysis Information Chunk

Analysis information are stored in XHDR chunks. Analysis information of dual capture waveforms during dual capturing is stored in DHDR chunks.

An analysis information chunk starts with a 4-byte "XHDR" identifier and ends with a 4-byte 0xFFFFFFFF end mark. The eight bytes immediately after the "XHDR" identifier contains the data size (in bytes) of the analysis information chunk.

The content of the data is text information (described later), which closely resembles the information in YOKOGAWA's legacy WVF and HDR files.

offset	Type	Identifier	byte	Description
0x0000	CHR	ChunkType	4	Chunk type "XHDR" or "DHDR"
0x0004	UINT64	Length	8	Data size
0x000C	-	Data	-	Analysis information (text information)
	UINT	EndMark	4	0xffffffff or the data's CRC32 value

Analysis Information Overview

Analysis information data is big endian.

The data in analysis information chunks is text. The line feed code is "0x0A."

Analysis Information Example

The following example shows the waveform file analysis information containing four channels and five history entries.

```
//YOKOGAWA ASCII FILE FORMAT

$PublicInfo
FormatVersion 1.01
Model DL950
Endian Little
DataFormat Trace
GroupNumber 1
TraceTotalNumber 4
DataOffset 1577850

$Group1
TraceNumber 4
BlockNumber 5
TraceName CH1 CH3 CH5 CH7
BlockSize 10001 10001 10001 10001
VResolution 2.0833333E-03 8.3333333E-03 4.1666667E-02 8.3333333E-04
VOffset 0.0000000E+00 0.0000000E+00 0.0000000E+00 0.0000000E+00
VDataType IS2 IS2 IS2 IS2
VUnit V V V V
VPlusOverData ? ? ? ?
VMinusOverData ? ? ? ?
VIllegalData -32768 -32768 -32768 -32768
VMaxData 32767 32767 32767 32767
VMinData -32767 -32767 -32767 -32767
VResolution 1.0000000E-05 1.0000000E-05 1.0000000E-05 1.0000000E-05
HOffset -5.0000000E-02 -5.0000000E-02 -5.0000000E-02 -5.0000000E-02
HUnit s s s s
Date 2020/12/23 2020/12/23 2020/12/23 2020/12/23
Time 16:58:37.197522070 16:58:37.197522070 16:58:37.197522070 16:58:37.197522070

$PrivateInfo
DisplayPointNo. 0
ModeVersion 0.95
ModuleName 720212 720250 720250 720211 720212 720212 720242 720212
StartOffset1 0.0 0.0 0.0 0.0
StartOffset2 0.0 0.0 0.0 0.0
StartOffset3 0.0 0.0 0.0 0.0
StartOffset4 0.0 0.0 0.0 0.0
StartOffset5 0.0 0.0 0.0 0.0
TrigTime1 2020/12/23 16:58:37.197522070
TrigTime2 2020/12/23 16:58:37.337523700
TrigTime3 2020/12/23 16:58:37.477525340
TrigTime4 2020/12/23 16:58:37.617526980
TrigTime5 2020/12/23 16:58:37.757528620
HOffset1 -5.0000000E-02 -5.0000000E-02 -5.0000000E-02 -5.0000000E-02
HOffset2 -5.0000000E-02 -5.0000000E-02 -5.0000000E-02 -5.0000000E-02
HOffset3 -5.0000000E-02 -5.0000000E-02 -5.0000000E-02 -5.0000000E-02
HOffset4 -5.0000000E-02 -5.0000000E-02 -5.0000000E-02 -5.0000000E-02
HOffset5 -5.0000000E-02 -5.0000000E-02 -5.0000000E-02 -5.0000000E-02
BlockSize1 10001 10001 10001 10001
BlockSize2 10001 10001 10001 10001
BlockSize3 10001 10001 10001 10001
BlockSize4 10001 10001 10001 10001
BlockSize5 10001 10001 10001 10001
UpperScale 2.5000000E+01 1.0000000E+02 5.0000000E+02 1.0000000E+01
LowerScale -2.5000000E+01 -1.0000000E+02 -5.0000000E+02 -1.0000000E+01
DataEnd
```

Description of Parameters in Analysis Information

//YOKOGAWA.ASCII FILE FORMAT	A line that starts with "/" is a comment line.
\$PublicInfo	A label that indicates common information. A label always starts with a dollar (\$) mark. The character code of the dollar mark is 0x24.
FormatVersion	Version number of this piece of analysis information
Model	Model of the measuring instrument that generated the file
Endian	Big or Little. All files generated by the instrument are big endian.
Trace	Internal structure of the waveform data Trace or Block. All files generated by the instrument are Trace.
GroupNumber	Total number of groups in the analysis information
TraceTotalNumber	Number of traces that this data file contains
DataOffset	How many bytes into the file where binary data begins
\$Group	A label indicating the beginning of group information
TraceNumber	Number of traces in the relevant group
BlockNumber	Number of history entries
TraceName	Trace label of each trace
BlockSize	Number of data points in the block corresponding to the trace name
VResolution	Y-axis conversion coefficient of each trace
VOffset	Y-axis conversion offset of each trace The Y-axis value (vertical value) can be determined using the following conversion formula. $Y\text{-axis value} = V\text{Resolution} \times \text{binary data} + V\text{Offset}$
VDataType	Data type of each trace (details provided separately)
VUnit	Y-axis unit
VPlusOverData, VMinusOverData	(Reserved)
VIllegalData	Indicates illegal data when an illegal calculation is performed (such as dividing by 0) or hidden code for preventing the data from being displayed on the screen
VMaxData, VMinData	Maximum and minimum values that data may take on in this block of each trace
HResolution, HOffset	Coefficient and offset of time-axis conversion of each trace $\text{Time-axis value} = H\text{Resolution} \times (\text{data number} - 1) + H\text{Offset}$
HUnit	Time-axis unit
Date	Date of the first (oldest) history number
Time	Time of the first (oldest) history number
\$PublicInfo	
DisplayPointNo.	How many points into the waveform data where measurement start point begins
ModelVersion	Firmware version number
StartOffset1	Number of phase difference points per trace (history number at the end)
DateTime1	Time reference time for each history entry (trigger time) (history number at the end)
DataEnd	End of information

Data Type Expression (VDataType)

Type of waveform data stored in a file is indicated by the VDataType field

VDataType is a 3-character text string. The definition of each character is provided below.

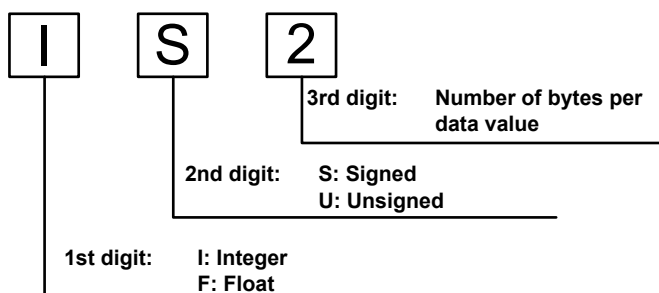

However, for bit data only three digits consisting of B+(2-digit decimal) is used.

Appendix

The data types are shown below.

Module/Data Type	Bit Count	Value Type	VDataType
2-CH and 4-CH modules, SCAN, temperature SCAN, Math	—		IS2
RTMath	—		FS4*
LOGIC menu	—		B16
CAN, CAN/CAN FD, CAN/LIN	2 to 16	Unsign	IU2
	2 to 16	Sign	IS2
	17 to 32	Unsign	IU4
	17 to 32	Sign	IS4
	—	Float	IS2
	1 to 8	Logic	B16
SENT	1 to 16	Unsign	IU2
	1 to 16	Sign	IS2

* For power math (/G05 option), a portion of the channels become IU8.

Bit data is stored in 16 bits. The bits are arranged in order from the least significant bit (bit 1 to bit 8), and the highest 8 bits are not used.

Waveform Data

Waveform data begins DataOffset bytes into the file.¹

Data is arranged in order by trace. The number of data points is indicated by BlockSize of each trace in the waveform analysis information. The data size of each point is indicated by VDataType.

Due to different sampling rates on the measurement module, the number of data points may vary for each trace.

For waveform data saved using the “history all” feature, the data of all history entries is stored for each trace. The history entries are arranged in order from the oldest to the most recent. The number of stored history entries can be verified by BlockNumber in the waveform analysis information.

Data example saved for one history entry

Trace -1
Trace -2
Trace -3
Trace -4

Data example saved using “history all”

Trace -1	History -n
:	
Trace -1	History -1
Trace -1	History -0
Trace -2	History -n
:	
Trace -2	History -1
Trace -2	History -0

¹ “DrAW” chunks hold waveform data (“dsRW” chunks hold dual capture waveforms). A “DrAW” chunk contains “the data size in chunk” followed by the file data size (4 bytes) and file number (4 bytes). DataOffset points to the head of the raw data, which comes after these pieces of data. In the case of a “dsRW” chunk (used in dual capturing), the head of the raw data comes immediately after “the data size in chunk,” and thus DataOffset (DHDR) also points to this position.

StartOffset

Sub channel data may not begin from the first point of the main channel data.

In such a case, it begins after the “start offset” of the main channel data.

Normally, this information does not need to be considered.

Label	Item	Description	Number of Parameters	Notes	Data Example	
\$Public Info		A label indicating the beginning of common information	0			
	Format Version	File format version number	1		1.00	
	Model	Measuring instrument model		DL950		
	Endian	Waveform data endianness		Big		
	Data Format	Waveform data save format (Trace or Block)		Fixed to Trace	Trace	
	Group Number	Number of trace groups		2		
	TraceTotal Number	Number of traces		8		
	Data Offset	Offset in waveform data file		682874		
			Label indicating the beginning of a group (a number from 1 to GroupNumber is attached to the end)	0		
		Trace Number	Number of traces in the group	1		4
		Block Number	Number of history entries		5	
		Trace Name	Trace name (label)	Trace Number (1 to 4)	Spaces are converted to underscores.	CH1
		BlockSize	Number of data points		10010	
		V Resolution	Y-axis conversion coefficient (VResolution × raw data value + VOffset)		8.3333333E-04	
		VOffset	Y-axis offset		0.0000000E+00	
		VData Type	Binary data type (integer or real number, signed or unsigned, number of bytes per data)		IS2	
		VUnit	Y-axis unit		V	
		VPlusOver Data	Upper limit of normal data		Fixed to "?" for reserve	•
		VMinus Over Data	Lower limit of normal data		Fixed to "?" for reserve	•
		VIllegal Data	Hidden code value		"?" for modules that do not have a hidden code	-32768
		VMaxData	Maximum data value		Maximum value that the data type can take on	32767
		VMinData	Minimum data value		Minimum value that the data type can take on	-32767
		H Resolution	X-axis conversion coefficient (X-axis value = HResolution × (data number - 1) + HOffset)		1.0000000E-06	
		HOffset	X-axis offset		-5.0000000E03	
		HUnit	X-axis unit		s	
		Date	Time reference date		Only the first history entry when there are multiple entries. 8 decimal places for seconds for Time (nsec)	8/18/2013
		Time	Time reference time			14:23:30. 01234567
\$PrivateInfo		Label indicating the beginning of model-specific information	0			
	Display Point No.	How many points into the waveform data where measurement start point begins	TraceTotal Number	For WVF compatibility	1	
	Model Version	Firmware version number	1		3.01	
	Start Offset1	Number of phase difference points per trace (history number at the end)	TraceTotal Number	Output as many times as there are history entries	0 0 13	
	Date Time1	Time reference time for each history entry (trigger time) (history number at the end)	1	Output as many times as there are history entries	2013/08/18 14:23:30. 01234567	
	DataEnd	End of information	0			

Appendix 11 Digital Filter and Real Time Math

Digital Filter Operation Type

The instrument has the following two digital filter operation types.

- FIR
- IIR

FIR

The signal block diagram for math that uses an FIR digital filter is shown below. The FIR filter has the following features:

1. A steep, high-order filter can be achieved within the range of the math time.
However, as the order becomes higher, the math delay becomes longer.
2. Because the filter has linear phase characteristics, it has a constant group delay. Therefore, it has a small amount of phase distortion.

In real time math, the following filters can be used as FIR filters:

- Sharp (Sharp)
- Gauss (Gauss)
- Mean

Signal Block Diagram of an FIR Filter

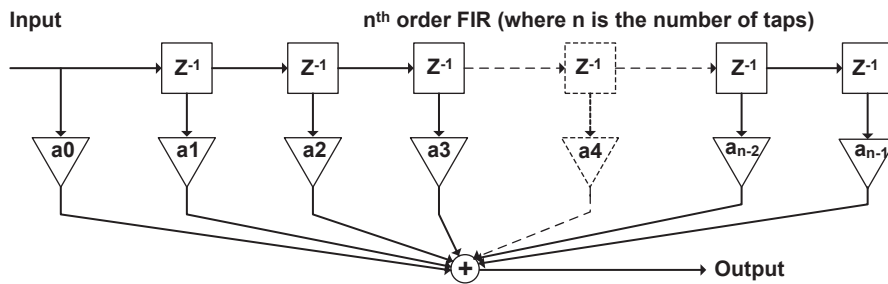

IIR

The signal block diagram for math that uses an IIR digital filter is shown below. The IIR filter has the following features:

1. Even with comparatively low orders, the filter can obtain sufficient cutoff characteristics. Therefore, the math delay and group delay are small compared to FIR.
2. The frequency can be set to a lower value than is possible with FIR.
3. Because it has non-linear phase characteristics, the phase distortion of an IIR filter is greater than that of an FIR filter.

In real time math, a Butterworth filter, which has characteristics similar to an analog filter, can be used as an IIR filter.

Signal Block Diagram of an IIR Filter

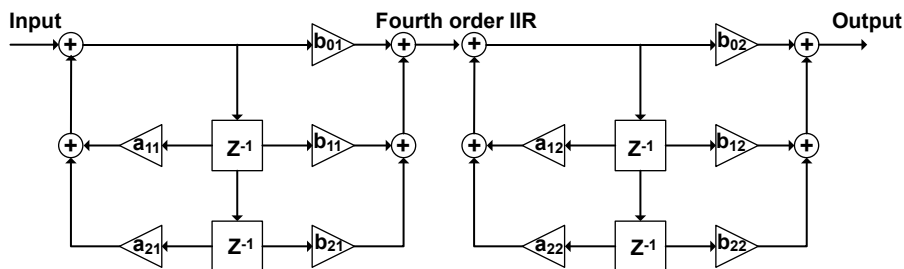

Filter Features

The features of each filter are listed below.

Type	Features	Bandwidth	Operation Type
Sharp (Sharp)	Frequency characteristics with a sharp attenuation slope (–40 dB at 1 oct)	Lowpass	FIR
	Linear phase and constant group delay	Highpass	
	Ripples present in the passband Comb-shaped stopband	BandPass	
Gauss (Gauss)	Frequency characteristics with a smooth attenuation slope Linear phase and constant group delay No ripples present in the passband No overshoot in the step response Low order and short delay	Lowpass	FIR
Mean (moving average)	Comb-shaped frequency characteristics Linear phase and constant group delay No overshoot in the step response	Lowpass	FIR
IIR (Butterworth)	Attenuation slope steepness between those of the Sharp and Gauss filters	Lowpass	IIR
	Non-linear phase and non-constant group delay	Highpass	
	No ripples present in the passband and stopband	BandPass	
	Compared to Sharp and Gauss filters, lower cutoff frequency possible Characteristics similar to those of analog filters		
IIR-Lowpass	Frequency characteristics with a smooth attenuation slope Calculation period is fixed to 10 MHz, regardless of the cutoff. Non-linear phase Characteristics similar to those of analog filters	Lowpass	IIR

Type	Passband Ripple	Attenuation Slope	Stopband Attenuation	Phase	Selectable Cutoff Range
Sharp (Sharp)	0 dB	–40 dB at 1 oct (Low Pass)	–40 dB	Linear phase	2 to 30 % of the calculation frequency
		–40 dB at –1 oct (High Pass)			
Gauss (Gauss)	±0.3 dB	$-3.0 \times (f/f_c)^2$ dB		Linear phase	2 to 30 % of the calculation frequency
Mean (moving average)	0 dB	See the characteristics graph		Linear phase	—
IIR (Butterworth)	0 dB	–24 dB at 1 oct (Low Pass)		Non-linear phase	0.2 to 30 % of the calculation frequency
		–24 dB at –1 oct (High Pass)			
IIR-Lowpass	0 dB	–12 dB at 1 oct		Non-linear phase	

About the Group Delay Characteristic

In the filter response characteristics, the delay (in seconds) between the input frequency (sine wave) and the output frequency is known as group delay. The group delay can be normalized by the calculation period (T_s). Group delay is expressed in units of s/T_s . The length of the group delay for each frequency can be determined by the following equation: "group delay of the frequency × calculation period."

Example

The length of the group delay for the mean can be calculated as shown below (the group delay is constant, regardless of the frequency).

Group delay (in s/T_s) when the mean filter is used = (number of mean points – 1)/2

If there are 16 mean points,

Group delay (in s/T_s) = $(16 - 1)/2 = 15/2 = 7.5 s/T_s$.

If the calculation frequency (f_s) is 100 kHz,

$T_s = 1/f_s = 1/(100 \text{ kHz}) = 10 \mu\text{s}$.

Therefore,

Length of delay = Group delay × calculation period = $7.5 s/T_s \times 10 \mu\text{s} = 75 \mu\text{s}$.

About the Calculation Frequency

With the digital filter, the calculation frequency is automatically set internally depending on the cutoff frequency. The calculation frequencies are shown below.

Digital Filter	
Cutoff Frequency Range	Calculation Frequency
300 kHz to 30 kHz	1 MHz
29.8 kHz to 3 kHz	100 kHz
2.98 kHz to 300 Hz	10 kHz
298 Hz to 30 Hz	1 kHz
29.8 Hz or less	100 Hz

The signal input to the digital filter is decimated to the calculation cycle determined by this calculation frequency, but it is passed through an anti-aliasing filter in advance. The configuration of the anti-aliasing filter is as follows.

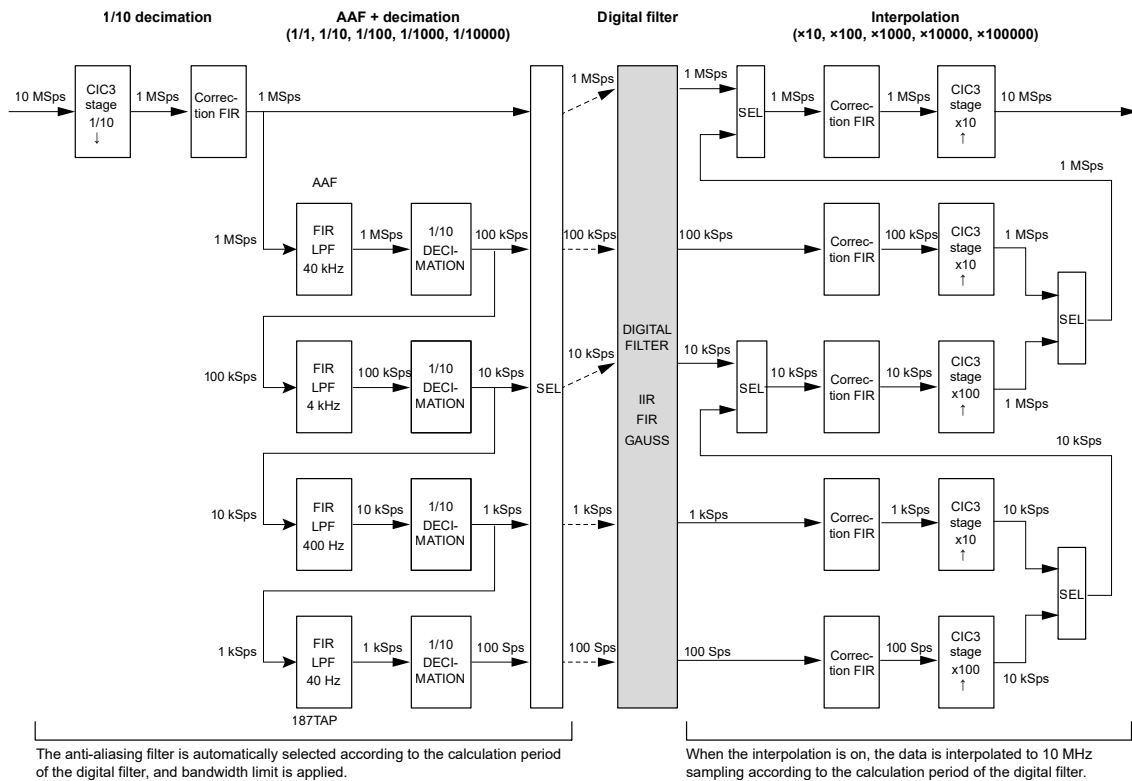

The filter response of the anti-aliasing filter is as follows.

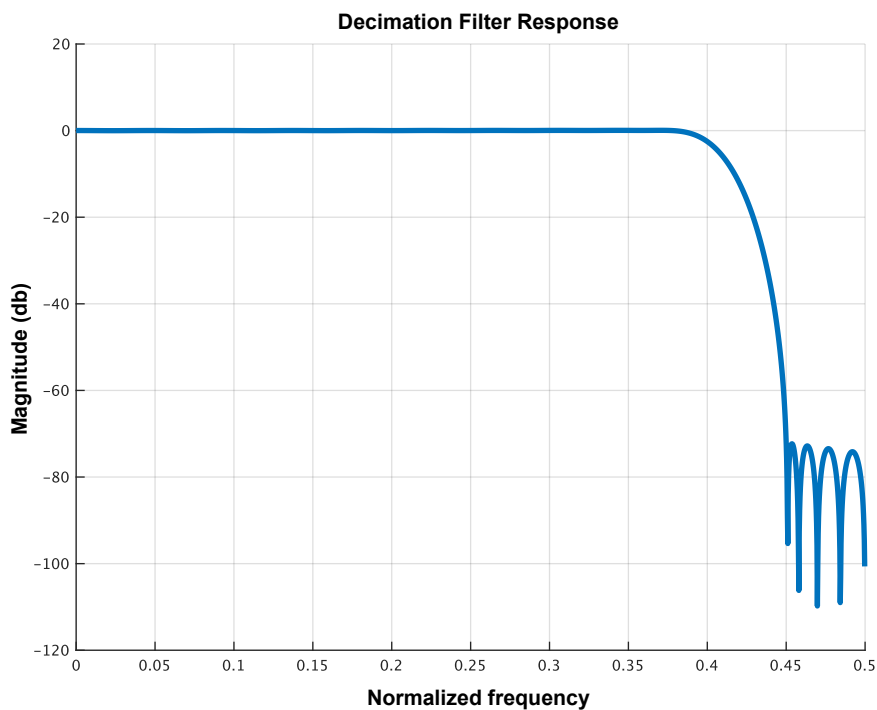

When a high-pass filter is used, the bandwidth of the signal input to the digital filter is limited by the anti-aliasing filter set based on the calculated frequency of the digital filter.

The output from the digital filter can be interpolated to a sample rate of 10 MHz by turning on the interpolation filter. If the interpolation filter is off, the output of the digital filter is updated every calculation cycle.

About the Math Delay

The math delay can be calculated from the following equation.

$$\text{Math delay} = 1.4 \mu\text{s} + \text{digital filter delay} + \text{math time}$$

If you are not using the digital filter and math features, the delay and math time both become 0.

The digital filter delay varies depending on the filter type and the calculation frequency. For details on the delay, see each filter's math delay explanation.

The math time is different for each function. A table of the math times for each function is shown below.

functions	Computation Time [μs]	Notes
A(S1)+B(S2)+C	0.0	
A(S1)-B(S2)+C	0.0	
A(S1)*B(S2)+C	0.0	
A(S1)/B(S2)+C	0.0	
Diff	See the filter explanations.	
Integ1	0.2	
Integ2	0.2	
Angle	0.2	
DA	0.2	
Polynomial	0.8	Data is updated every 1 μs.
RMS	0.6	The data is updated once per the specified period.
Power	0.4	The data is updated once per the specified period.
Power Integ	0.2	
Log1	0.4	
Log2	0.2	
Sqrt1	0.2	
Sqrt2	0.0	
Cos	0.2	
Sin	0.2	
Atan	0.3	
Electric Angle	1.1	The data is updated once per the specified period.
Knocking Filter	0.0	
Poly-Add-Sub	0.0	
Frequency	0.2	The data is updated each time that an edge is detected.
Period	0.2	The data is updated each time that an edge is detected.
Edge Count	0.2	The data is updated each time that an edge is detected.
Resolver	0.4	The data is updated once per excitation voltage period.
IIR Filter	See the filter explanations.	
PWM	0.2	
Reactive Power	0.2	
CAN ID	The calculation period is from the last bit sample point of the CAN frame ID to the point of detection. The sample point is approximately at the 70 % point of the time span of a bit.	
Torque	0.4	The data is updated each time that an edge is detected.
S1-S2(Angle)	0.0	
3 Phase Resolver	0.4	The data is updated once per excitation voltage period.

Sharp Filter

Characteristics

Low-Pass and High-Pass

- The ripple that is present in the passband is within 0.3 dB.
- When the frequency is equal to the cutoff frequency times 2 for low-pass or the cutoff frequency times 0.5 for high-pass, the attenuation is set to 40 dB.
- The stopband attenuation is -40 dB or greater.
- The filter has linear phase and constant group delay.

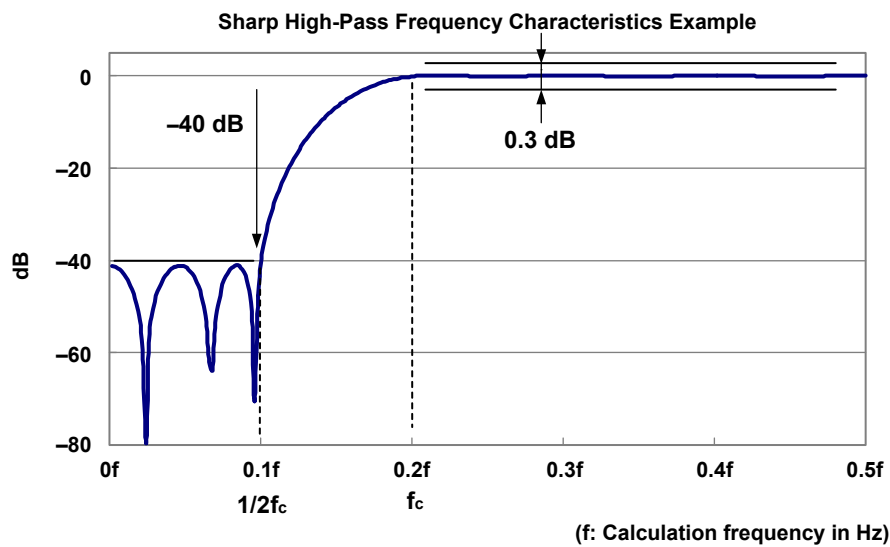
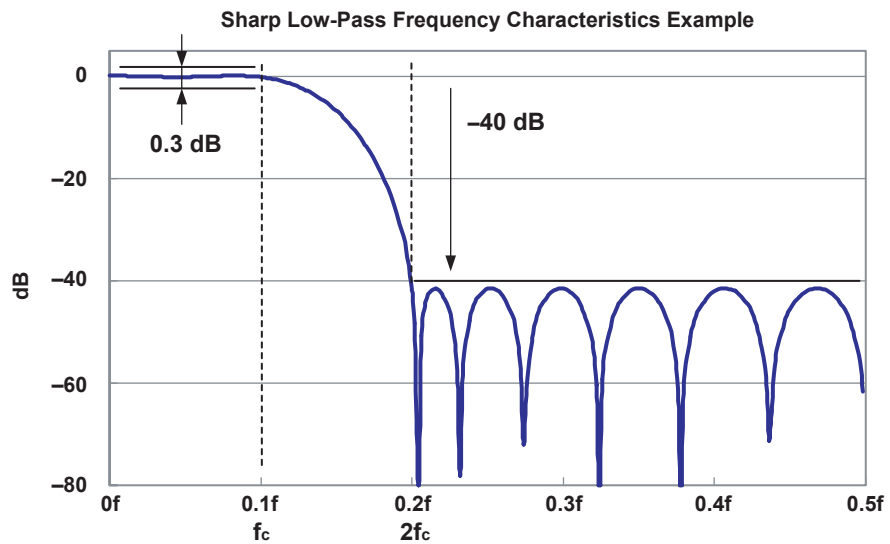

Band-Pass

- The ripple that is present in the passband is within 0.3 dB.
- In the low frequency band, when the frequency becomes half the frequency that was present at edge f_{cl} of the passband, the attenuation is set to -40 dB.
- In the high frequency band, the width of the transition area, in which the frequency is attenuated -40 dB from the passband edge, is approximately the same as the width of the transition area in the low frequency band.
 $(f_{cl} - 1/2f_{cl} = f_{cus} - f_{cu})$
- The stopband attenuation is -40 dB or greater.
- The filter has linear phase and constant group delay.

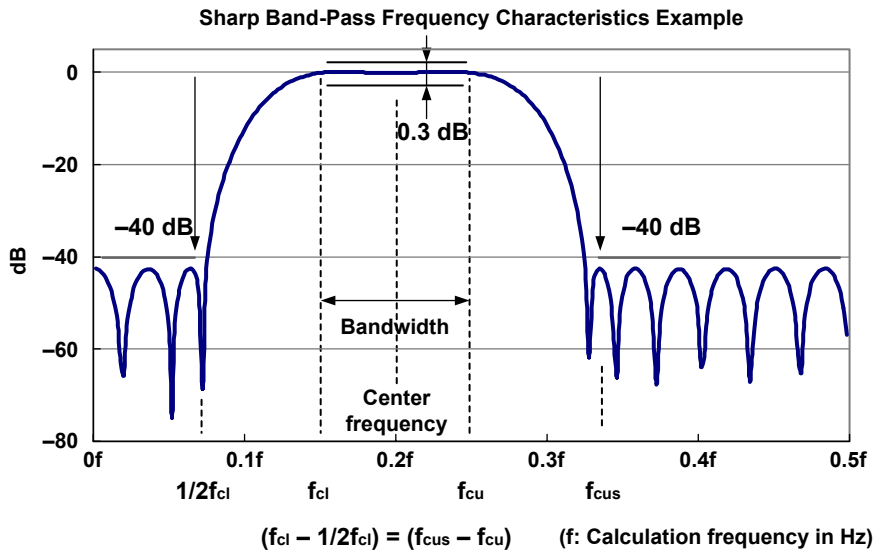

In the sharp band-pass filter, the bandwidth options vary depending on the center frequency.

Sharp Band-Pass Filter Frequency Range

Center Frequency (kHz)	Bandwidth Setting (kHz)	Calculation Frequency (Hz)
300 to 120	200, 150, 100, 50, 20	1 M
118 to 96	150, 100, 50, 20	1 M
94 to 70	100, 50, 20	1 M
68 to 46	50, 20	1 M
44 to 30	20	1 M
29.8 to 12	20, 15, 10, 5, 2	100 k
11.8 to 9.6	15, 10, 5, 2	100 k
9.4 to 7	10, 5, 2	100 k
6.8 to 4.6	5, 2	100 k
4.4 to 3	2	100 k
2.98 to 1.2	2, 1.5, 1, 0.5, 0.2	10 k
1.18 to 0.96	1.5, 1, 0.5, 0.2	10 k
0.94 to 0.7	1, 0.5, 0.2	10 k
0.68 to 0.46	0.5, 0.2	10 k
0.44 to 0.3	0.2	10 k

Order Table

The orders of each Sharp filter are listed below. The cutoff and center frequency settings are given as percentages of the calculation frequency.

Sharp Low-Pass Filter Orders

Cutoff Frequency	2 %	3 %	4 %	5 %	6 %	7 %	8 %	9 %	10 %
Harmonic Order	94	61	46	37	32	28	24	22	20
Cutoff Frequency	11 %	12 %	13 %	14 %	15 %	16 %	17 %	18 %	19 %
Harmonic Order	17	17	15	14	13	13	11	11	11
Cutoff Frequency	20 %	21 %	22 %	23 %	24 %	25 %	26 %	27 %	28 %
Harmonic Order	10	11	9	9	8	8	8	8	8
Cutoff Frequency	29 %	30 %							
Harmonic Order	8	8							

Sharp High-Pass Filter Orders

Cutoff Frequency	2 %	3 %	4 %	5 %	6 %	7 %	8 %	9 %	10 %
Harmonic Order	191	127	97	77	65	55	49	45	39
Cutoff Frequency	11 %	12 %	13 %	14 %	15 %	16 %	17 %	18 %	19 %
Harmonic Order	37	33	31	29	27	25	25	23	23
Cutoff Frequency	20 %	21 %	22 %	23 %	24 %	25 %	26 %	27 %	28 %
Harmonic Order	21	21	19	19	19	17	17	17	15
Cutoff Frequency	29 %	30 %							
Harmonic Order	15	15							

Sharp Band-Pass Filter Orders (Passband width: 2 %)

Center Frequency	3 %	4 %	5 %	6 %	7 %	8 %	9 %	10 %	11 %
Harmonic Order	189	142	93	80	69	61	54	49	45
Center Frequency	12 %	13 %	14 %	15 %	16 %	17 %	18 %	19 %	20 %
Harmonic Order	41	37	34	32	27	20	18	18	17
Center Frequency	21 %	22 %	23 %	24 %	25 %	26 %	27 %	28 %	29 %
Harmonic Order	16	16	14	14	14	13	13	12	13
Center Frequency	30 %								
Harmonic Order	11								

Sharp Band-Pass Filter Orders (Passband width: 5 %)

Center Frequency	5 %	6 %	7 %	8 %	9 %	10 %	11 %	12 %	13 %
Harmonic Order	154	112	93	72	64	58	51	40	37
Center Frequency	14 %	15 %	16 %	17 %	18 %	19 %	20 %	21 %	22 %
Harmonic Order	35	33	31	29	28	26	25	24	23
Center Frequency	23 %	24 %	25 %	26 %	27 %	28 %	29 %	30 %	
Harmonic Order	22	21	20	19	19	18	17	18	

Sharp Band-Pass Filter Orders (Passband width: 10 %)

Center Frequency	7 %	8 %	9 %	10 %	11 %	12 %	13 %	14 %	15 %
Harmonic Order	194	132	97	78	69	57	52	47	39
Center Frequency	16 %	17 %	18 %	19 %	20 %	21 %	22 %	23 %	24 %
Harmonic Order	37	35	33	31	30	28	27	23	23
Center Frequency	25 %	26 %	27 %	28 %	29 %	30 %			
Harmonic Order	20	19	18	18	17	16			

Sharp Band-Pass Filter Orders (Passband width: 15 %)

Center Frequency	10 %	11 %	12 %	13 %	14 %	15 %	16 %	17 %	18 %
Harmonic Order	155	110	89	73	62	52	49	41	38
Center Frequency	19 %	20 %	21 %	22 %	23 %	24 %	25 %	26 %	27 %
Harmonic Order	36	34	32	27	26	25	24	23	22
Center Frequency	28 %	29 %	30 %						
Harmonic Order	21	21	21						

Sharp Band-Pass Filter Orders (Passband width: 20 %)

Center Frequency	12 %	13 %	14 %	15 %	16 %	17 %	18 %	19 %	20 %
Harmonic Order	191	129	98	78	67	58	49	46	40
Center Frequency	21 %	22 %	23 %	24 %	25 %	26 %	27 %	28 %	29 %
Harmonic Order	38	36	31	29	28	27	26	25	24
Center Frequency	30 %								
Harmonic Order	20								

math delay

The group delay can be calculated from the following equation. The group delay is constant based on the filter order.

$$\text{Group delay} = (\text{filter order} - 1)/2$$

Unit: s/Ts (Ts is the calculation period in seconds)

The math delay can be calculated from the following equation.

$$\text{Math delay} = 1.4 \mu\text{s} + \{(\text{filter order} - 1)/2\} \times \text{calculation period}$$

Examples of Characteristics

Sharp Low-Pass

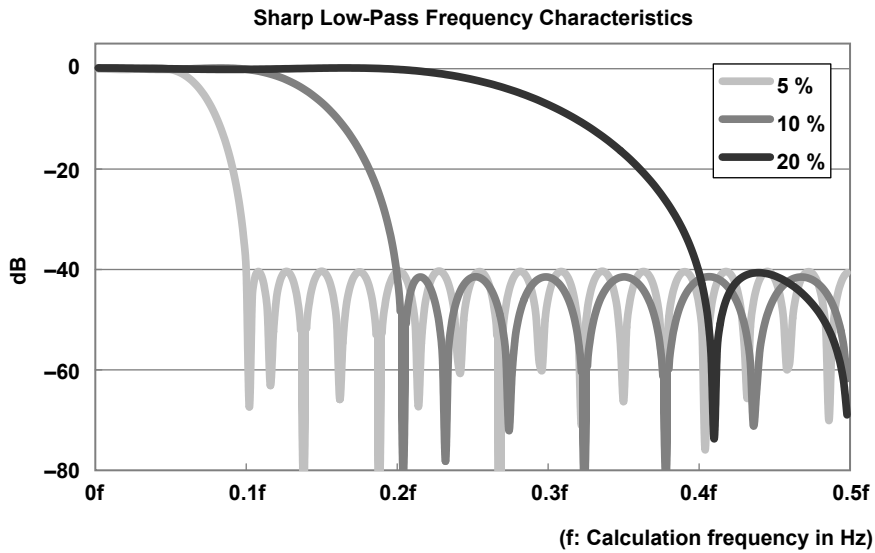

Sharp High-Pass

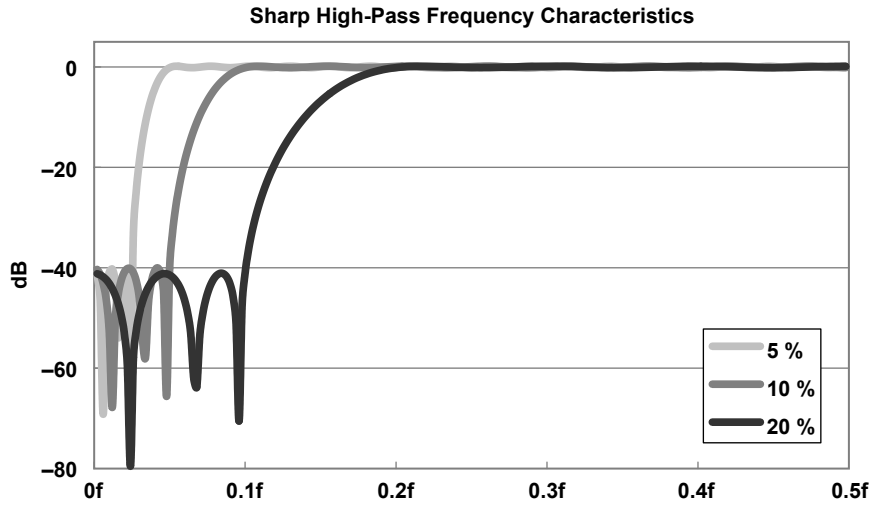

Sharp Band-Pass (Passband width: 2 %)

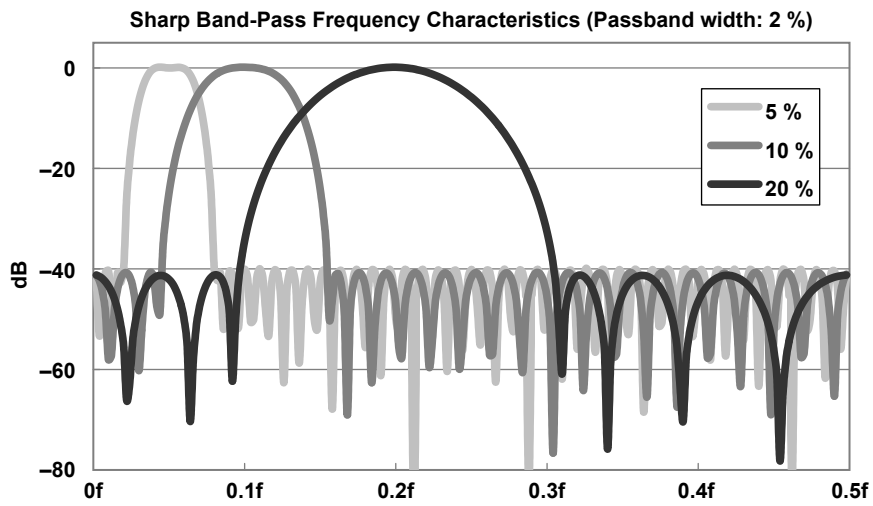

Sharp Band-Pass (Passband width: 5 %)

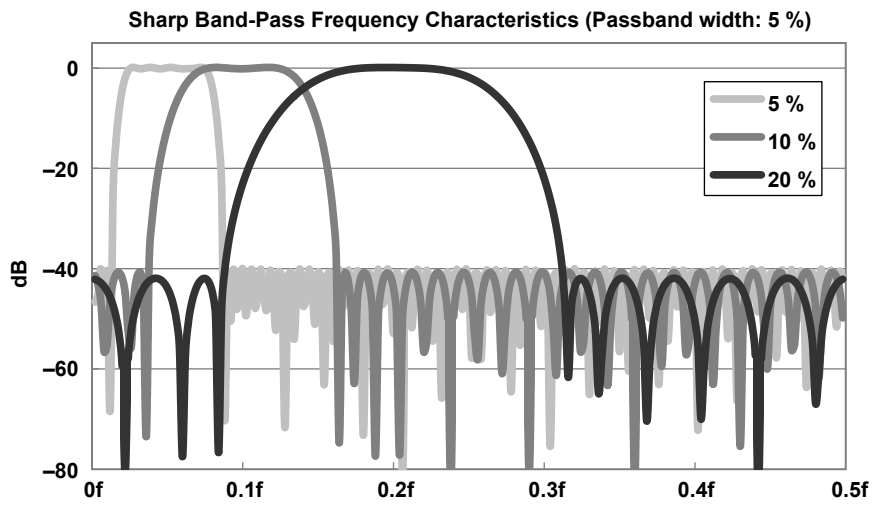

(f: Calculation frequency in Hz)

Sharp Band-Pass (Passband width: 10 %)

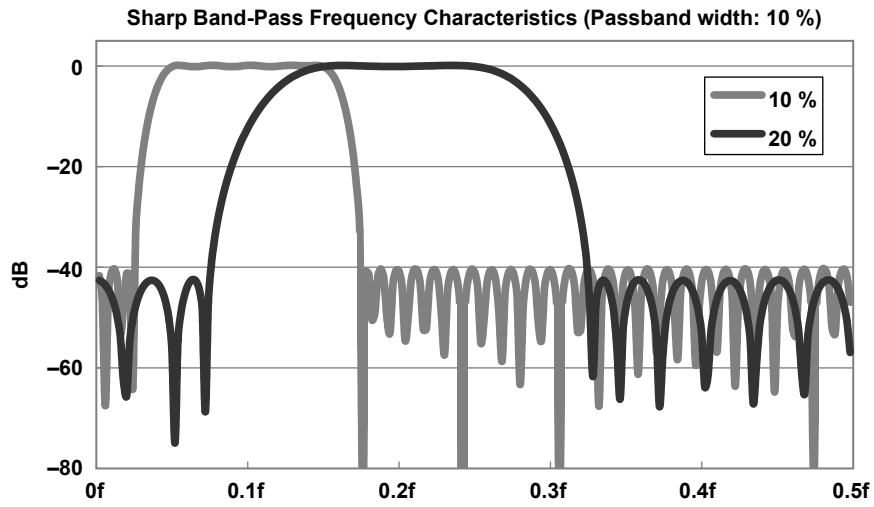

Sharp Band-Pass (Passband width: 15 %)

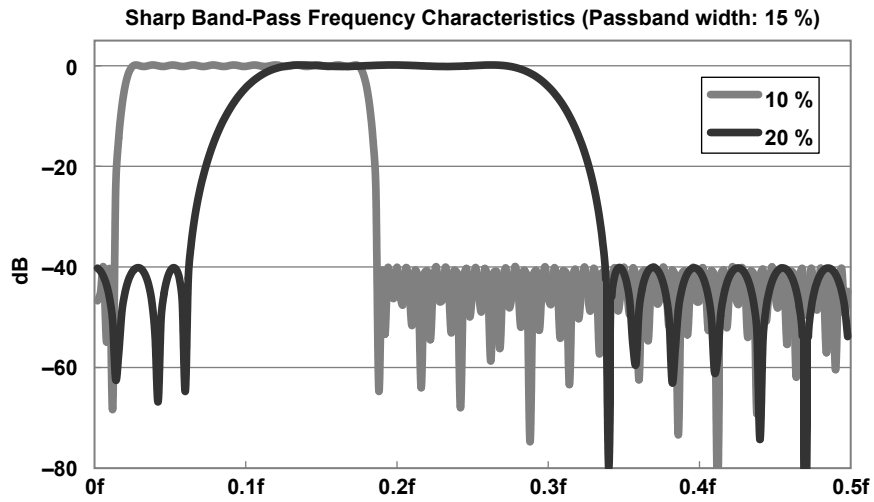

Sharp Band-Pass (Passband width: 20 %)

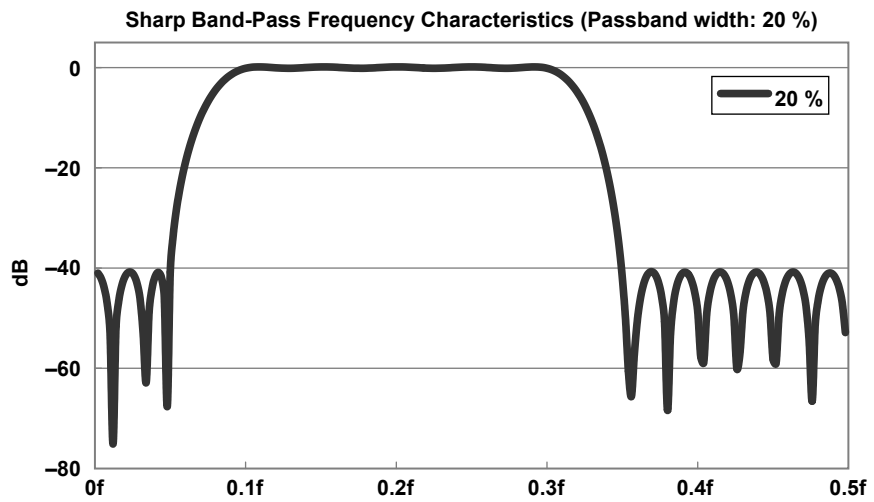

(f: Calculation frequency in Hz)

Gauss Filter

Characteristics

- The pass band is flat.
- At the cutoff frequency, the attenuation is -3 dB.
The damping rate is $-3.0 \times (f/f_c)^2$.
- The filter has linear phase and constant group delay.
- The filter can only be set to low-pass.

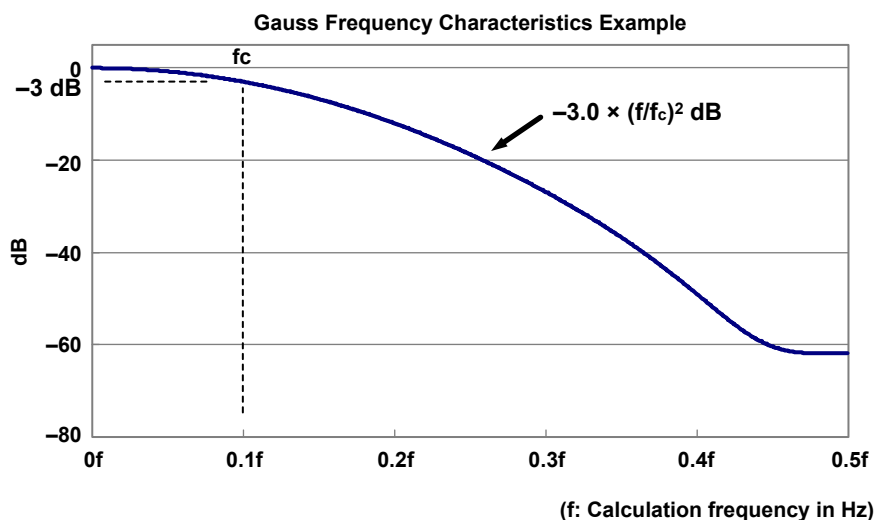

Order Table

The orders of the Gauss filter are shown below. The cutoff frequency settings are given as percentages of the calculation frequency.

Gauss Filter Orders

Cutoff Frequency	2 %	3 %	4 %	5 %	6 %	7 %	8 %	9 %	10 %
Harmonic Order	49	33	25	21	17	17	13	13	9
Cutoff Frequency	11 %	12 %	13 %	14 %	15 %	16 %	17 %	18 %	19 %
Harmonic Order	9	9	9	9	9	9	5	5	5
Cutoff Frequency	20 %	21 %	22 %	23 %	24 %	25 %	26 %	27 %	28 %
Harmonic Order	5	5	5	5	5	5	5	5	5
Cutoff Frequency	29 %	30 %							
Harmonic Order	5	5							

math delay

The group delay can be calculated from the following equation. The group delay is constant based on the filter order.

$$\text{Group delay} = (\text{filter order} - 1)/2$$

Unit: s/Ts (Ts is the calculation period in seconds)

The math delay can be calculated from the following equation.

$$\text{Math delay} = 1.4 \mu\text{s} + \{(\text{filter order} - 1)/2\} \times \text{calculation period}$$

Examples of Characteristics

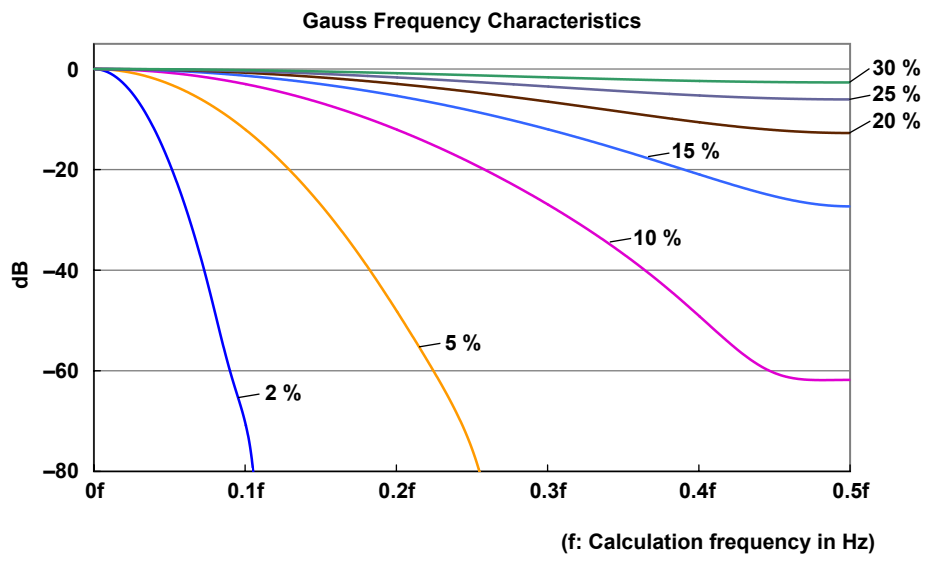

IIR (Butterworth)

Characteristics

Low-Pass and High-Pass

- This is a fourth order Butterworth filter. The damping rate is approximately -24 dB/oct.
- The pass band is flat.
- At the cutoff frequency, the attenuation is -3 dB.
- It has non-linear phase characteristics.
- You can set the frequency lower than other FIR filters.

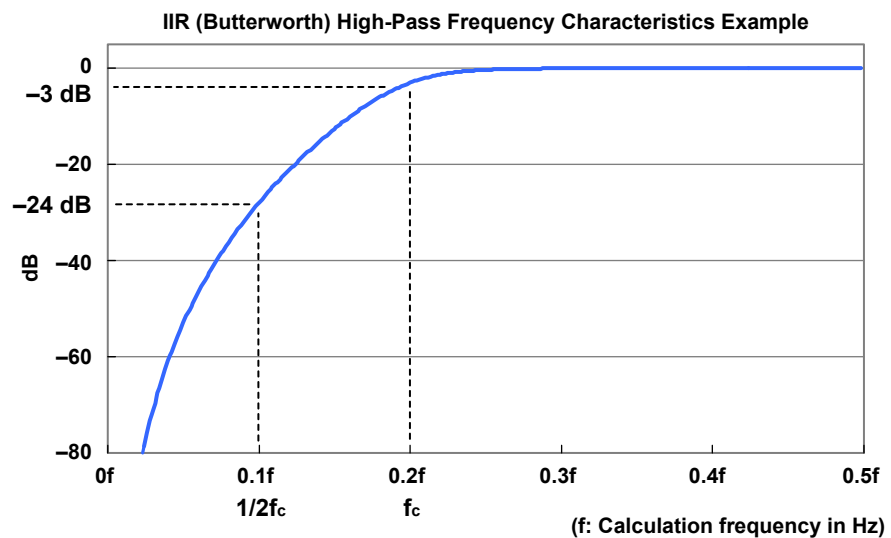
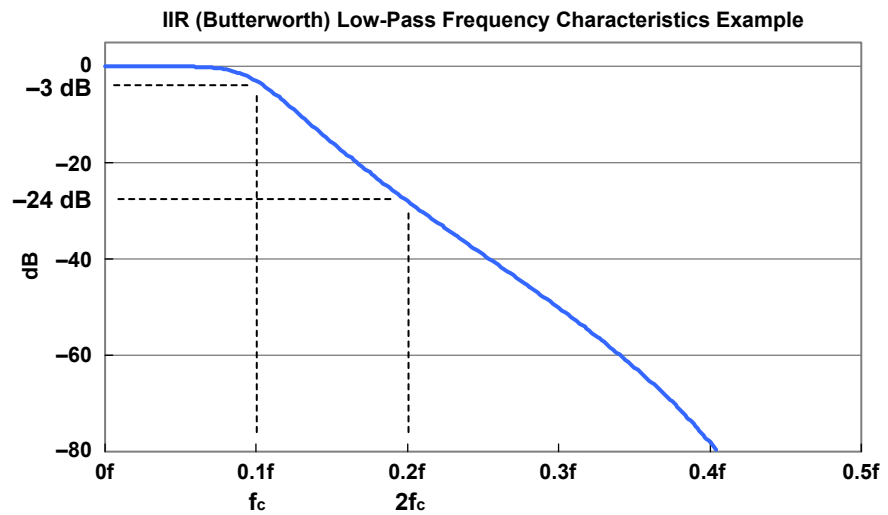

Band-Pass

- The pass band is flat.
- At each end of the passband, the attenuation is -3 dB.
- This is a fourth order Butterworth filter. There are no ripples present in the stopband. For the cutoff characteristic, see "Examples of Characteristics" later in this section.
- It has non-linear phase characteristics.
- You can set the frequency lower than the Sharp filter.

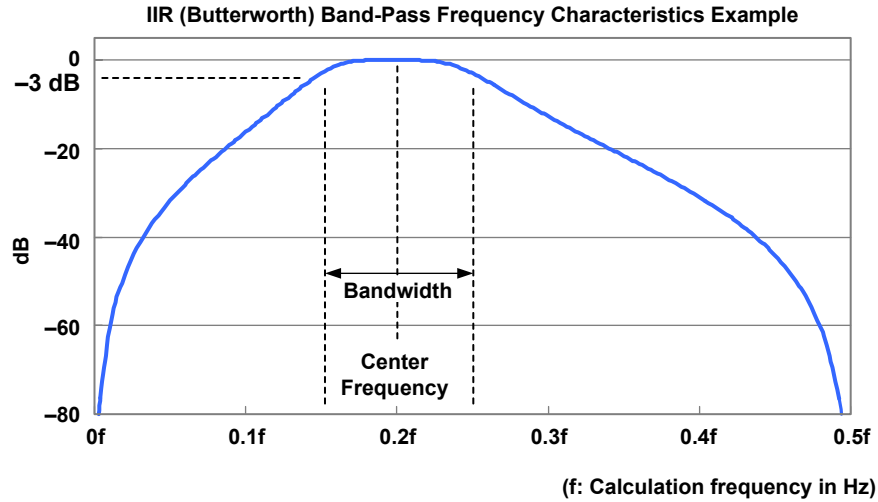

In the IIR (Butterworth) band-pass filter, the bandwidth options vary depending on the center frequency.

IIR (Butterworth) Band-Pass Filter Frequency Ranges

Center Frequency (kHz)	Bandwidth Setting (kHz)	Calculation Frequency (Hz)
300 to 102	200, 150, 100, 50, 20, 10	1 M
100 to 76	150, 100, 50, 20, 10	1 M
74 to 52	100, 50, 20, 10	1 M
50 to 26	50, 20, 10	1 M
24 to 12	20, 10	1 M
11.8 to 10.2	20, 15, 10, 5, 2, 1	100 k
10 to 7.6	15, 10, 5, 2, 1	100 k
7.4 to 5.2	10, 5, 2, 1	100 k
5 to 2.6	5, 2, 1	100 k
2.4 to 1.2	2, 1	100 k
1.18 to 1.02	2, 1.5, 1, 0.5, 0.2, 0.1	10 k
1 to 0.76	1.5, 1, 0.5, 0.2, 0.1	10 k
0.74 to 0.52	1, 0.5, 0.2, 0.1	10 k
0.5 to 0.26	0.5, 0.2, 0.1	10 k
0.24 to 0.12	0.2, 0.1	10 k
0.1 to 0.06	0.1	10 k

math delay

With IIR filters, unlike FIR filters, you cannot define the math delay. This is because the delay varies depending on the input frequency because of the non-linear phase characteristics of IIR filters. The group delay characteristic indicates the relationship between the frequency of the input signal and the math delay. The math delay can be calculated by adding 1.4 μs to the group delay characteristic.

The math delay can be calculated from the following equation.

$$\text{Math delay} = (1.4 \mu\text{s} + \text{group delay}) \times \text{calculation period}$$

Examples of Characteristics

IIR (Butterworth) Low-Pass

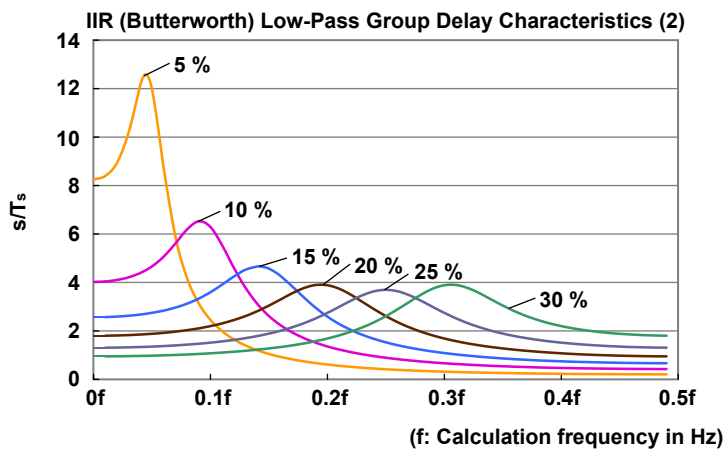
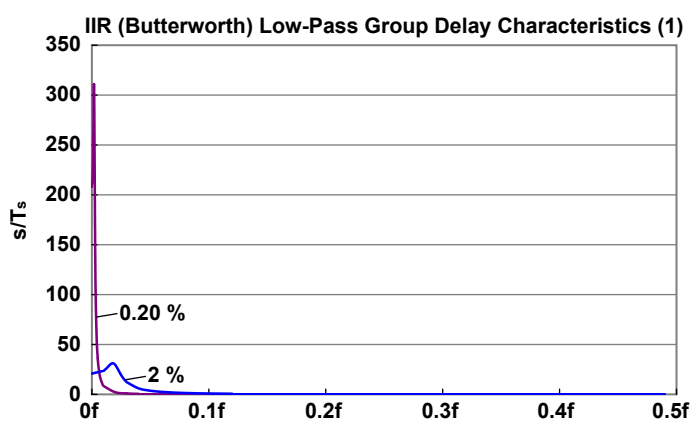
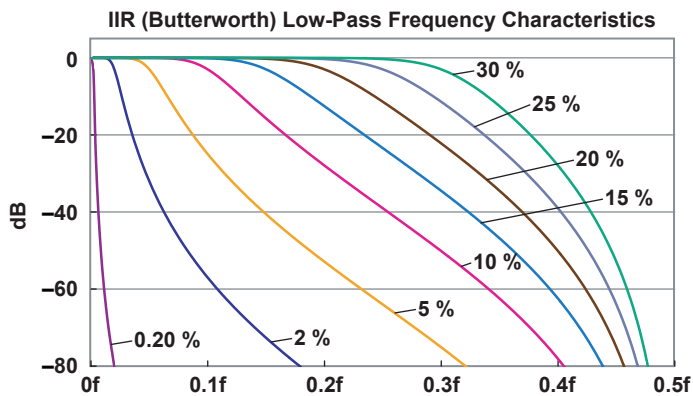

IIR (Butterworth) High-Pass

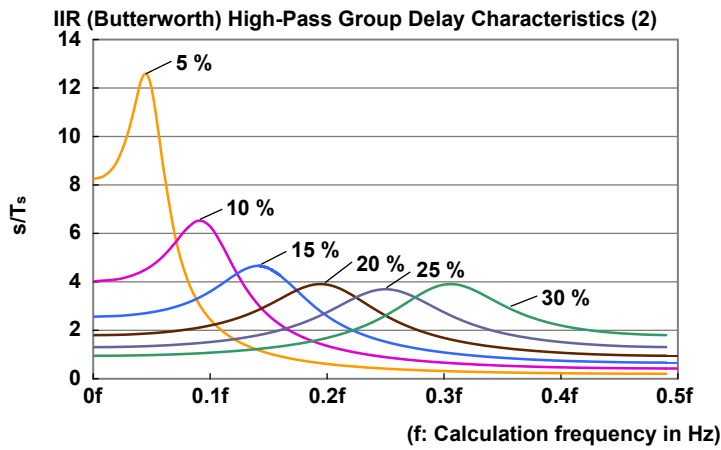
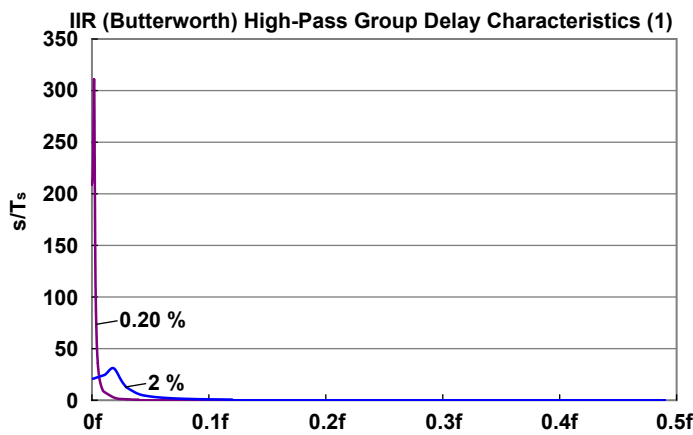
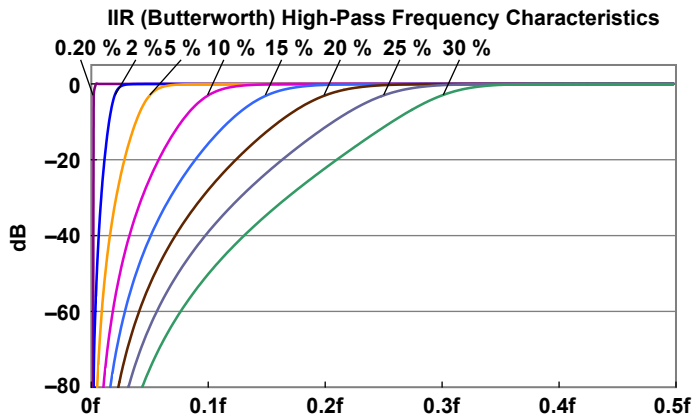

IIR (Butterworth) Band-Pass (Passband width: 1 %)

IIR (Butterworth) Band-Pass Frequency Characteristics (Passband width: 1 %)

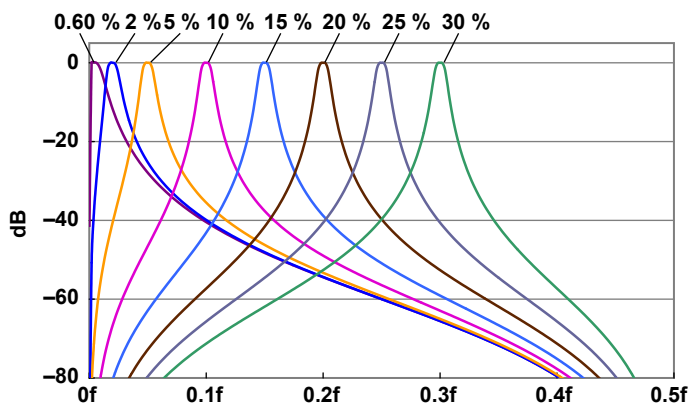

IIR (Butterworth) Band-Pass Group Delay Characteristics (1; passband width: 1 %)

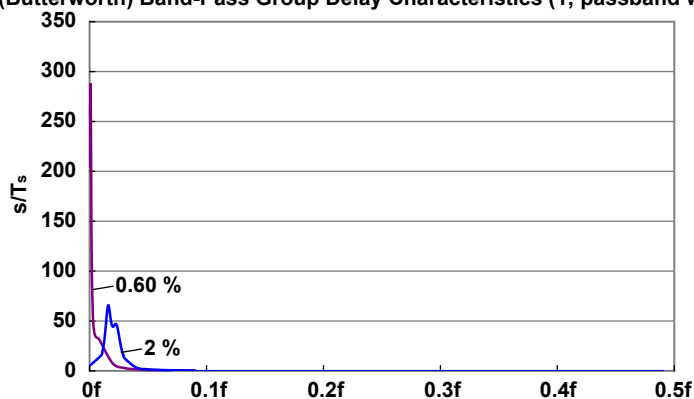

IIR (Butterworth) Band-Pass Group Delay Characteristics (2; passband width: 1 %)

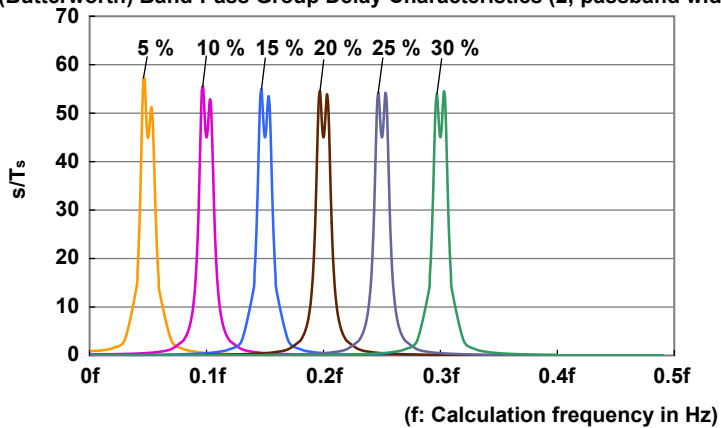

(f: Calculation frequency in Hz)

IIR (Butterworth) Band-Pass (Passband width: 2 %)

IIR (Butterworth) Band-Pass Frequency Characteristics (Passband width: 2 %)

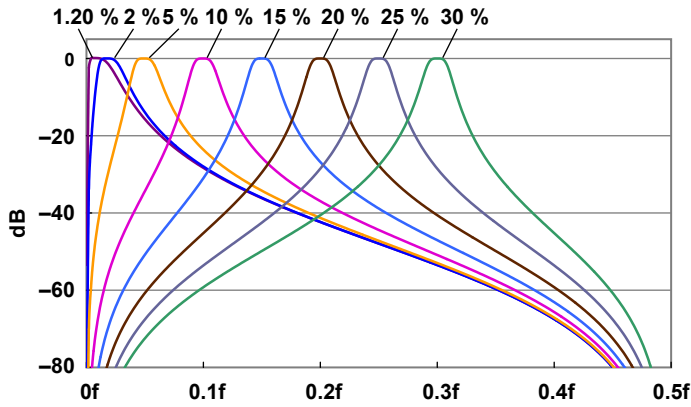

IIR (Butterworth) Band-Pass Group Delay Characteristics (1; passband width: 2 %)

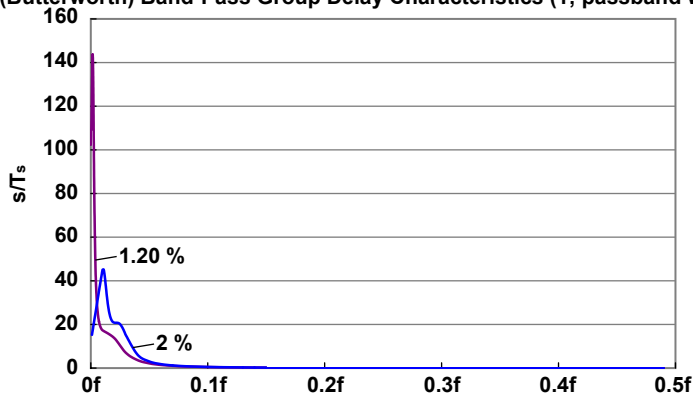

IIR (Butterworth) Band-Pass Group Delay Characteristics (2; passband width: 2 %)

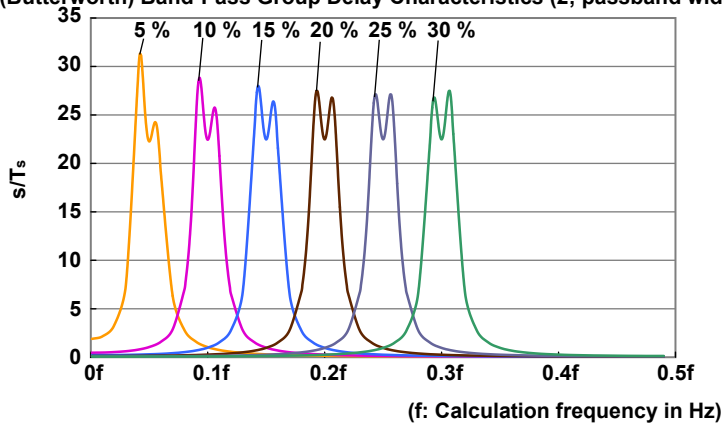

IIR (Butterworth) Band-Pass (Passband width: 5 %)

IIR (Butterworth) Band-Pass Frequency Characteristics (Passband width: 5 %)

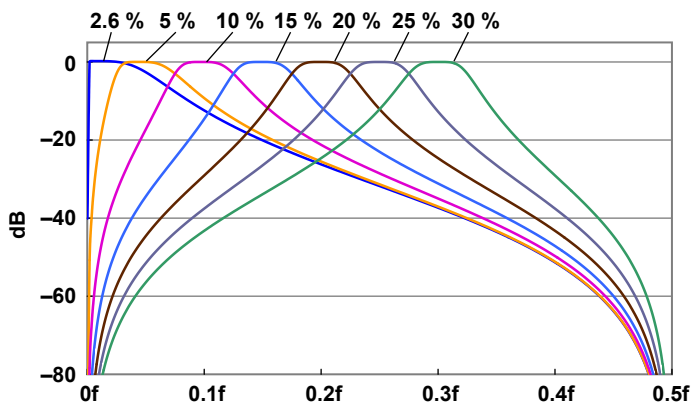

IIR (Butterworth) Band-Pass Group Delay Characteristics (1; passband width: 5 %)

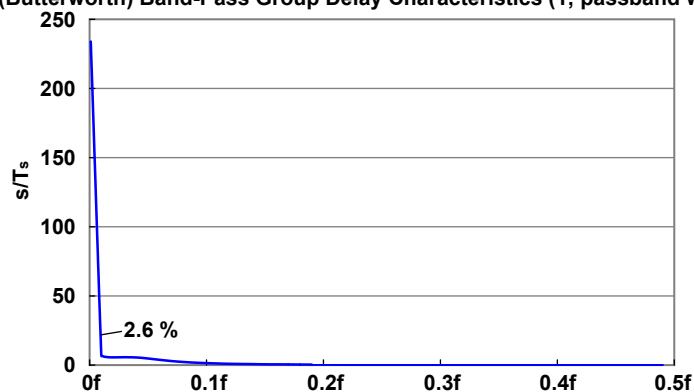

IIR (Butterworth) Band-Pass Group Delay Characteristics (2; passband width: 5 %)

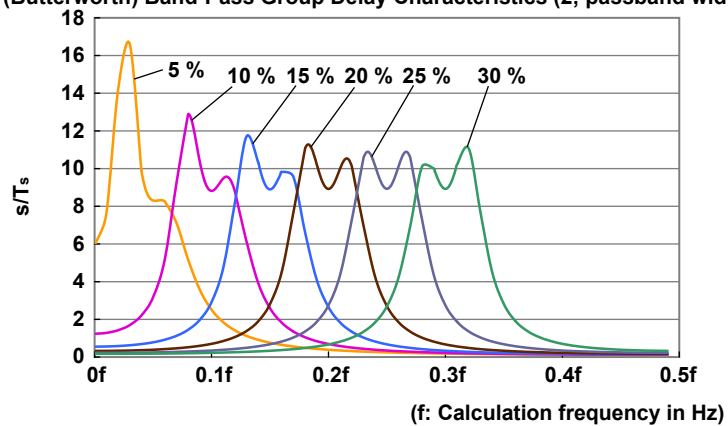

IIR (Butterworth) Band-Pass (Passband width: 10 %)

IIR (Butterworth) Band-Pass Frequency Characteristics (Passband width: 10 %)

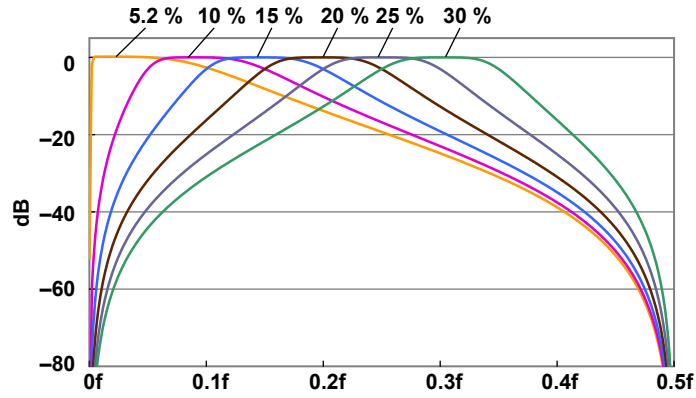

IIR (Butterworth) Band-Pass Group Delay Characteristics (1; passband width: 10 %)

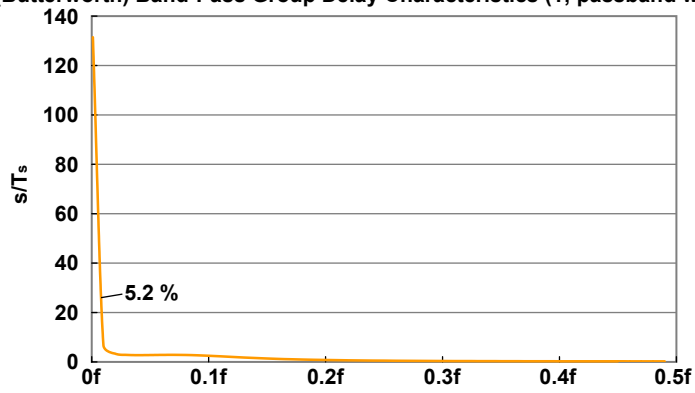

IIR (Butterworth) Band-Pass Group Delay Characteristics (2; passband width: 10 %)

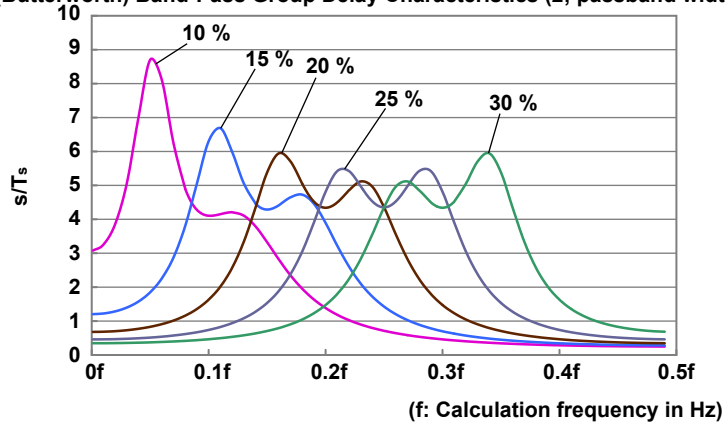

IIR (Butterworth) Band-Pass (Passband width: 15 %)

IIR (Butterworth) Band-Pass Frequency Characteristics (Passband width: 15 %)

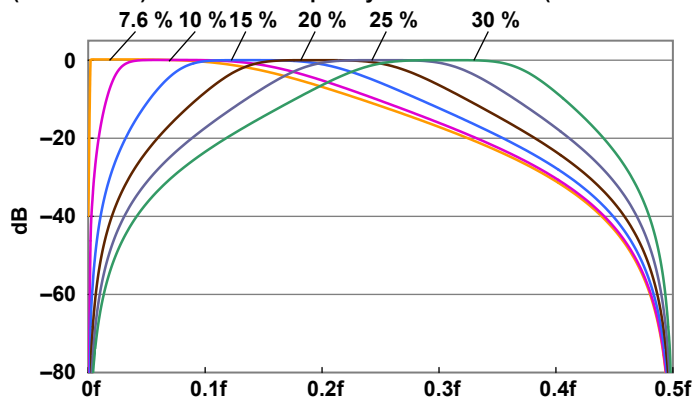

IIR (Butterworth) Band-Pass Group Delay Characteristics (1; passband width: 15 %)

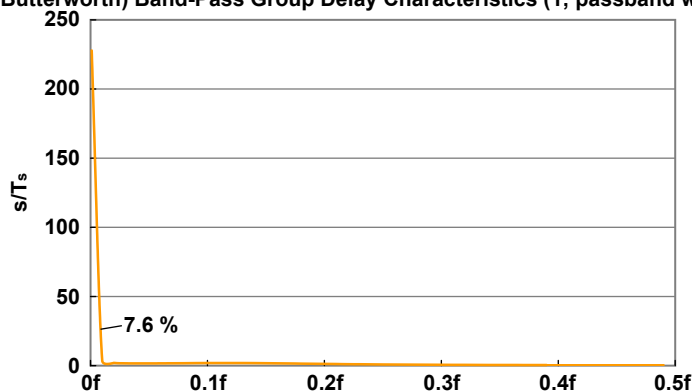

IIR (Butterworth) Band-Pass Group Delay Characteristics (2; passband width: 15 %)

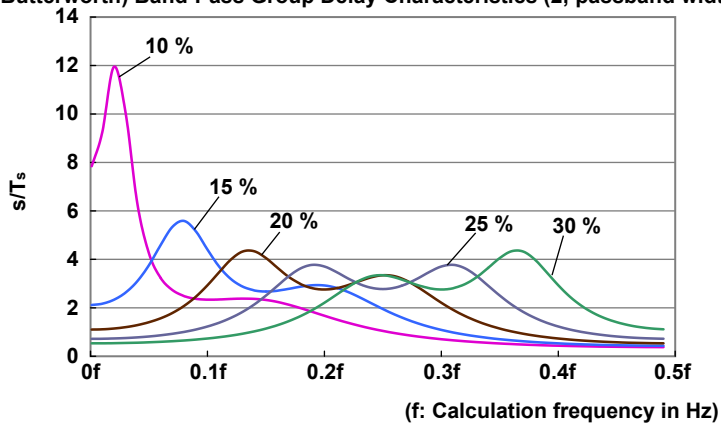

IIR (Butterworth) Band-Pass (Passband width: 20 %)

IIR (Butterworth) Band-Pass Frequency Characteristics (Passband width: 20 %)

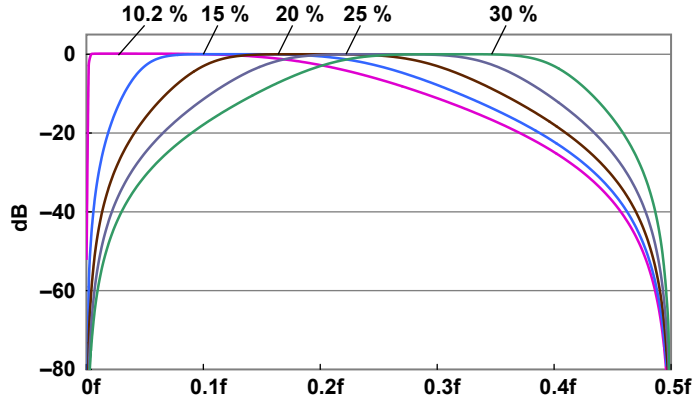

IIR (Butterworth) Band-Pass Group Delay Characteristics (1; passband width: 20 %)

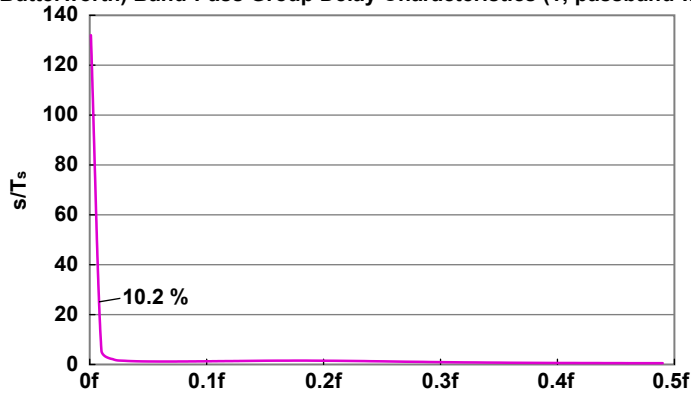

IIR (Butterworth) Band-Pass Group Delay Characteristics (2; passband width: 20 %)

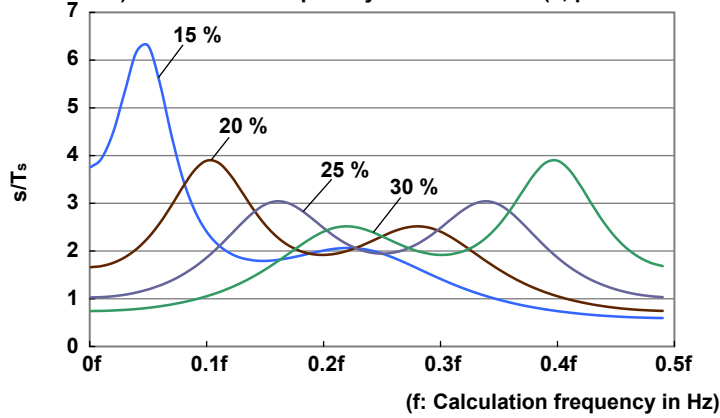

Mean (Moving Average) Filter

Characteristics

- The pass band is flat.
- The filter has linear phase and constant group delay.
- The characteristics are those of a low-pass filter.
- The filter has comb-shaped bandwidth characteristics.

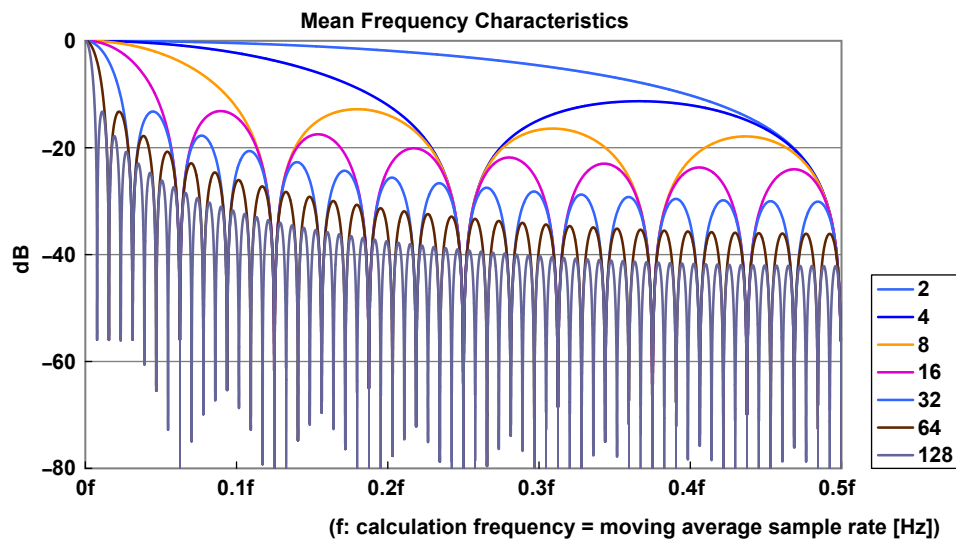

math delay

The group delay can be calculated from the following equation. The group delay is constant based on the filter order.

$$\text{Group delay} = (\text{number of mean points} - 1)/2$$

Unit: s/Ts (Ts is the calculation period in seconds)

The math delay can be calculated from the following equation.

$$\text{Math delay} = 1.4 \mu\text{s} + \{(\text{number of mean points} - 1)/2\} \times \text{calculation period}$$

IIR-Lowpass Filter

Characteristics

- The pass band is flat.
- It has non-linear phase characteristics.

Frequency Response

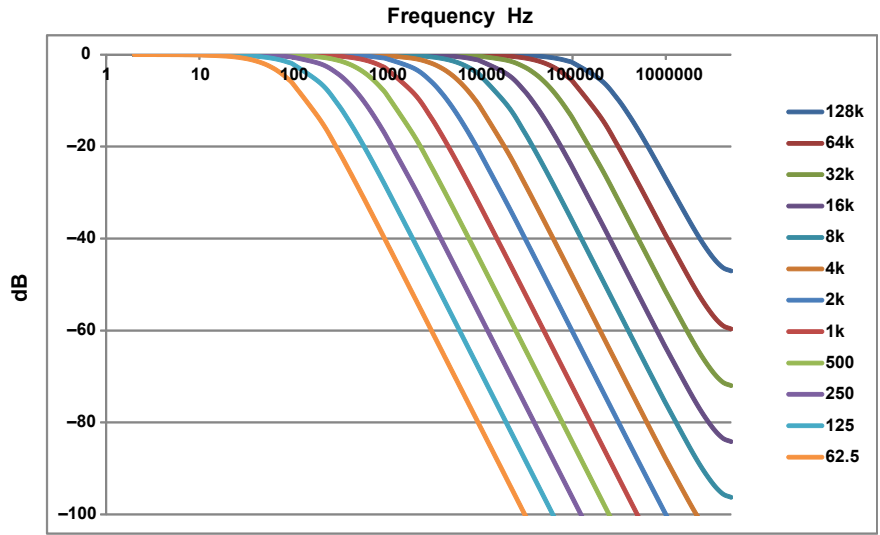

Phase Characteristics

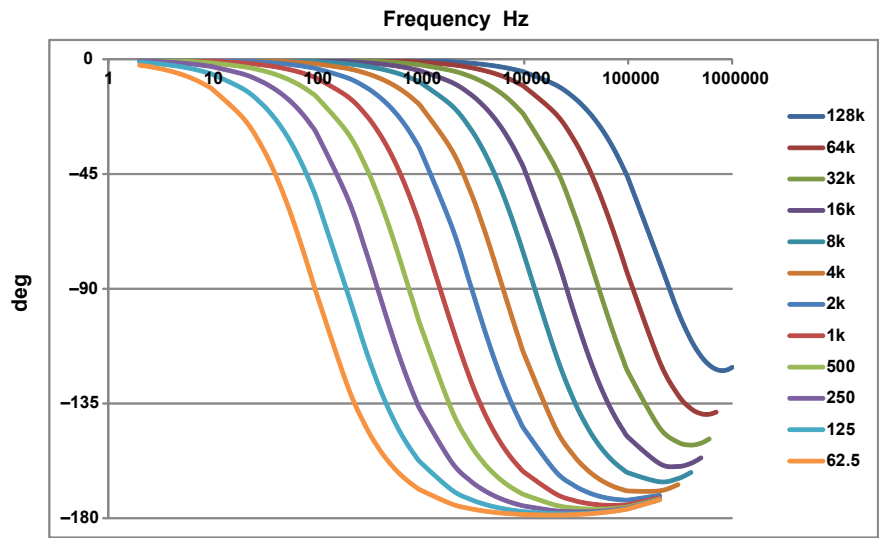

Real Time Math Differentiation

Differentiation Characteristics

The real time math differentiation operation uses a fifth order Lagrange interpolation formula to calculate the differentiated value. The fifth order Lagrange interpolation formula is shown below (see appendix 2).

$$fn' = 1/(12Ts)\{fn - 4 - 8fn - 3 + 8fn - 1 - fn\}$$

The following chart shows the amplitude characteristic in the case where the fifth order Lagrange interpolation formula is used and the ideal differentiation characteristic.

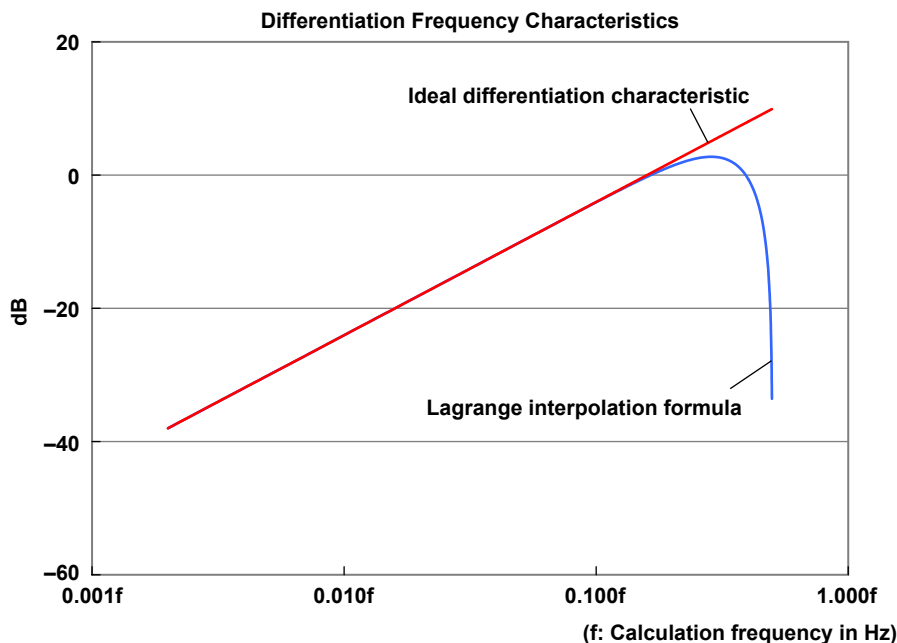

Up to the point where the input frequency is 20 % of the calculation period, the differentiation characteristic is almost the same as the ideal differentiation characteristic. At higher frequencies, the high frequency components are restrained by the high-area characteristics of the Lagrange interpolation formula.

Math Delay

The math delay is calculated using the following formula.

$$\text{Math delay} = 1.4 \mu\text{s} + 2 \times \text{calculation period}^*$$

* The "2" in the above formula is the delay due to the Lagrange interpolation formula.

About the Calculation Frequency

Differentiation is calculated at the DL950 sampling frequency. In dual capture mode, is calculated at the frequency of the low-speed sampling waveform.

However, the upper calculation frequency limit is 10 MHz. If the smaller sample rate exceeds this value, the calculation frequency is set to 10 MHz.

With external sampling, the calculation frequency is fixed to 10 MHz.

About the Electrical Angle

By using the electrical angle math operation, you can calculate the phase difference between the motor's input current and the motor's angle of rotation. By using an encoder, you can accurately measure the motor's mechanical angle of rotation, but the current waveform using this method is distorted because harmonic components are overlaid on top of it. In situations such as this, the phase difference between the motor's mechanical angle of rotation and its current cannot be determined in a simple manner.

The real time math feature uses a discrete Fourier transform to determine the fundamental component of the current waveform, and then calculates the phase difference between this fundamental component and the motor's mechanical angle of rotation.

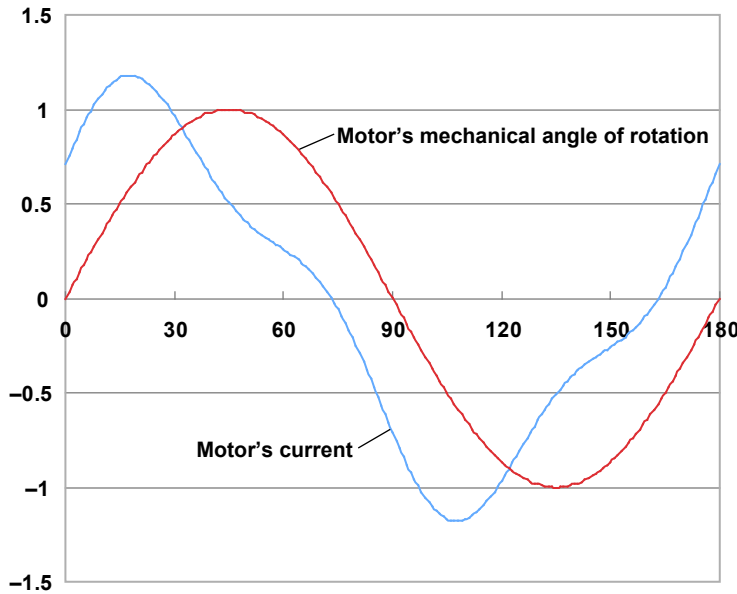

The phase difference is calculated with the motor's mechanical angle of rotation as the reference. If the phase is leading the motor's mechanical angle of rotation, the phase is displayed as a positive value.

Resolver

The angle of rotation is calculated from the excitation signal applied to the resolver and the sine signal and cosine signal that are generated from the detection coil of the resolver. To calculate the angle of rotation precisely, the data of the largest points (the peak values) of the carrier component of the sine and cosine signals are sampled, and the calculation is performed.

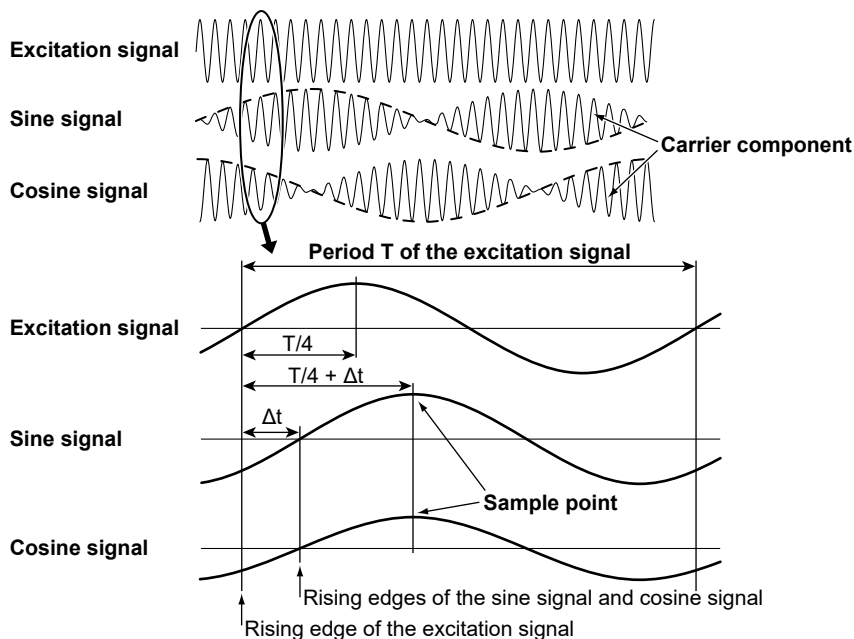

When the Sample Mode Is Set to Auto

The rising edge of the excitation signal is detected, and period T of the excitation signal is measured. The rising edges of the sine and cosine signals are also detected, and the time difference Δt between these rising edges and the rising edge of the excitation signal is measured. From period T and time difference Δt , the data at point $T/4 + \Delta t$ is sampled.

- The Auto setting can be applied when the time difference Δt of the sine and cosine signals in reference to the excitation signal is less than $\pm 90^\circ(T/4)$.
- Turn the SCALE knob to set the vertical scale (V/div) so that the amplitudes of the excitation, sine, and cosine signals are all ± 1.5 div or greater. If the amplitudes are less than ± 1.5 divisions, the Auto function will not operate.

When the Sample Mode Is Set to Manual

- The rising edge of the excitation signal is detected, and the data at the point at the specified time after this detected rising edge is sampled.

Tracking Filter

Because the resolver generates discrete signals, the calculation results are also discrete. The instrument can use a tracking filter to convert the calculation results into a smooth, continuous wave.

The tracking filter has a low pass filter. If you set a high cutoff frequency, you can measure a signal that has faster rotations and a higher angular acceleration (change in the number of rotations). On the other hand, the stability and angle resolution in measurements during constant velocity rotations decrease.

The relationship between cutoff frequency and maximum measurable angular acceleration (measurement of the change in the number of rotations) is shown below.

Cutoff Frequency	Maximum measurable angle acceleration
2 kHz	140000 rps ²
1 kHz	54000 rps ²
250 kHz	1800 rps ²
100 Hz	180 rps ²

When the rotation is fast, if you specify a low cutoff frequency, the instrument may not be able to calculate the angle correctly. In this situation, set the cutoff frequency to a large value.

Math Flowchart and Internal Math Expressions of Real Time Math

The math flowchart of real time math is shown below.

The input 16-bit binary data is converted to 32-bit floating point with a weight of 1LSB. If the input is 12-bit or 14-bit, it is converted to 16-bit and then to 32-bit floating point.

In real time math, the data is calculated with 32-bit floating point, and the calculated result is also stored in the acquisition memory with 32-bit floating point.

For displaying, the 32-bit floating-point data is converted into display data by the value determined by the display range value (Value/DIV).

Math Input: Conversion of 16-Bit Binary Data to Floating-Point Data

Math source data is acquired into real time math, and at the same time, is converted with 1 LSB weight into floating-point format.

$$A(\text{float}) = A(\text{binary}) \times (1 \text{ LSB weight})$$

$$B(\text{float}) = B(\text{binary}) \times (1 \text{ LSB weight})$$

Internal Math

All internal real time math operations are performed using floating-point data.

$$\text{Example: } C(\text{float}) = A(\text{float}) + B(\text{float})$$

Calculation for Display

The data stored in the acquisition memory is converted into display data by the value per display division determined by the display range value (Value/DIV) and displayed. Since the display process is performed after the data is stored in the acquisition memory, the display area can be changed without affecting the resolution of the floating-point data stored in the acquisition memory.

Math Data Flowchart

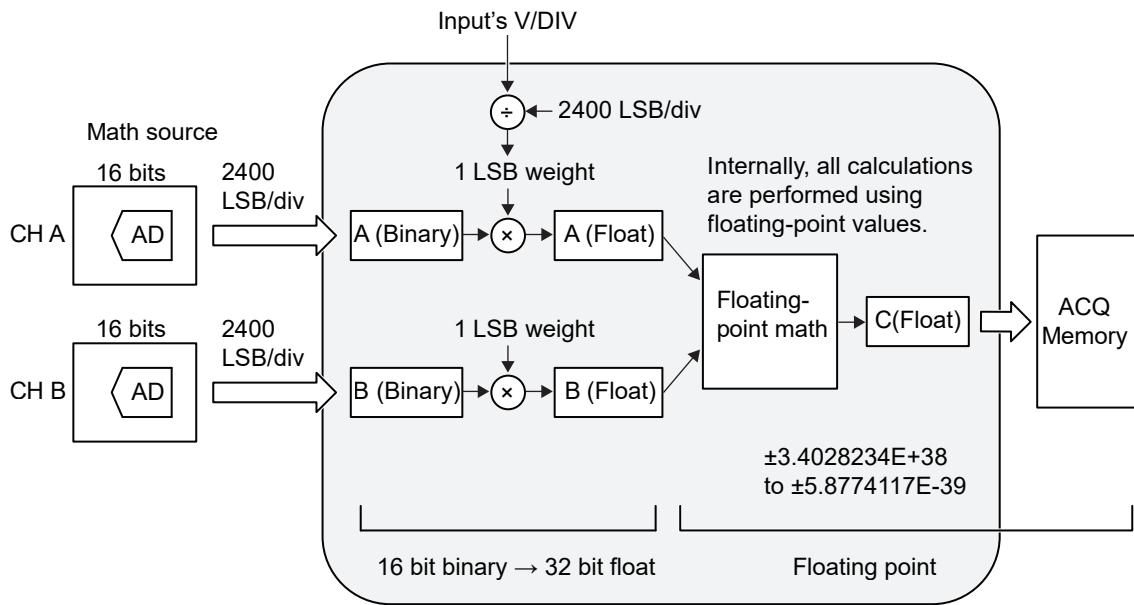

Display Data Flowchart

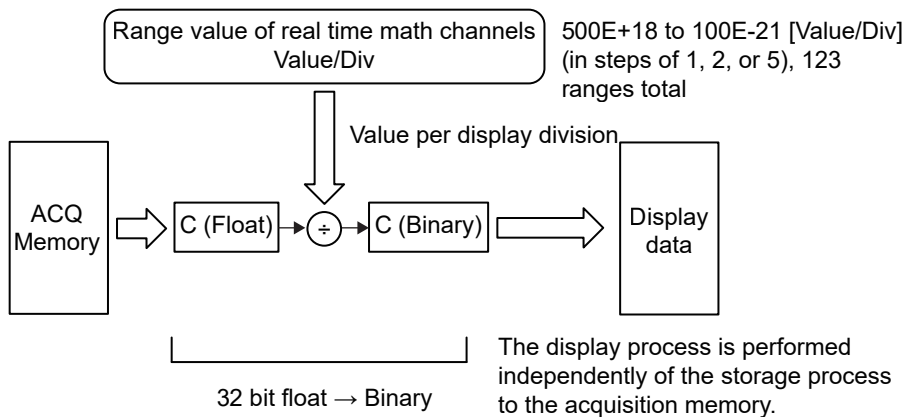

Appendix 12 Equations for Power Analysis and Harmonic Analysis

Power Analysis Equation (For Each Source Channel)

Urms, Irms (True Rms Value, RMS)

These values are the true rms values of the voltage and current. The instantaneous values over one period are squared and averaged. Then, the square root of the value is determined. $u(n)$ is the instantaneous voltage, $i(n)$ is the instantaneous current, n is the n th calculation period based on the synchronization source setting, and T is the number of samples.

$$U_{rms} = \sqrt{\frac{1}{T} \int_0^T u(n)^2 dt} \quad I_{rms} = \sqrt{\frac{1}{T} \int_0^T i(n)^2 dt}$$

Umn, Imn (Rectified Mean Value Calibrated to the Rms Value, MEAN)

This function rectifies one period of the voltage or current signal, determines the average, and multiplies the result by a coefficient. The coefficient is a value that when applied to a sinusoidal input signal, gives the true rms value. When the input signal is a distorted or is a DC waveform, these values will differ from the true rms values. $u(n)$ is the instantaneous voltage, $i(n)$ is the instantaneous current, n is the n th calculation period based on the synchronization source setting, and T is the number of samples.

$$U_{mn} = \frac{\pi}{2\sqrt{2}} \cdot \frac{1}{T} \int_0^T |u(n)| dt \quad I_{mn} = \frac{\pi}{2\sqrt{2}} \cdot \frac{1}{T} \int_0^T |i(n)| dt$$



You can select RMS or MEAN on the instrument. Regardless of which you select, the values are displayed as U_{rms} and I_{rms} on the instrument screen.

Udc, Idc (Simple Average, DC)

These are the average values over one period of the voltage and current signals. This function is useful when determining the average value of a DC input signal or a DC component that is superimposed on an AC input signal. $u(n)$ is the instantaneous voltage, $i(n)$ is the instantaneous current, n is the n th calculation period based on the synchronization source setting, and T is the number of samples.

$$U_{dc} = \frac{1}{T} \int_0^T u(n) dt \quad I_{dc} = \frac{1}{T} \int_0^T i(n) dt$$

Uac, Iac (AC Component, AC)

These are the AC components of the voltage and current. They are the square root values of the difference of the square of the true rms values of the input signal and the square of the DC component.

$$U_{ac} = \sqrt{U_{rms}^2 - U_{dc}^2} \quad I_{ac} = \sqrt{I_{rms}^2 - I_{dc}^2}$$

P (Active Power)

This value is determined by multiplying together the instantaneous voltages and currents over one period and taking the average. $u(n)$ is the instantaneous voltage, $i(n)$ is the instantaneous current, n is the n th calculation period based on the synchronization source setting, and T is the number of samples.

$$P = \frac{1}{T} \int_0^T u(n) \cdot i(n) dt$$

S (Apparent Power)

This value is determined by multiplying together the rms voltages and currents over one period.

$$P = U_{rms} \cdot I_{rms}$$

Q (Reactive Power)

This is the square root of the difference of the square of the apparent power and the square of the active power over one period.

The lowercase "s" is -1 for lead and 1 for lag.

$$Q = s \sqrt{S^2 - P^2}$$

λ (power factor)

This value is determined by dividing the active power by the apparent power over one period.

$$\lambda = \frac{P}{S}$$

ϕ (Phase Angle)

This is the arc cosine (\cos^{-1}) of the value obtained by dividing the active power by the apparent power over one period.

The value is negative for lead and positive for lag.

$$\phi = \cos^{-1} \left(\frac{P}{S} \right)$$

WP (Integrated Power), WP+ (Positive Integrated Power: Consumed Watt-Hours), WP- (Negative Integrated Power: Watt-Hours Returned to the Power Supply)

These values are determined by multiplying together the instantaneous voltages and currents and integrating them for the number of samples.

$$WP, WP+, \text{ or } WP- = \int_0^T u(n) \cdot i(n) dt$$

q (Integrated Ampere-Hour), q+ (Positive Integrated Ampere-Hour), q- (Negative Integrated Ampere-Hour)

These values are determined by integrating the currents for the number of samples.

$$q = \int_0^T I_{rms} dt \text{ or } q+, q- = \int_0^T i(n) dt$$

WS (Volt-Ampere Hours)

This value is determined by multiplying together the rms voltages and currents over one period and integrating them for the number of samples.

$$WS = \int_0^T U_{rms} \cdot I_{rms} dt$$

WQ (Var Hours)

This value is determined by taking the square root of the difference of the square of the apparent power and the square of the active power over one period and integrating them for the number of samples. The lowercase "s" is -1 for lead and 1 for lag.

$$WQ = \int_0^T s \sqrt{S^2 - P^2} dt$$

Impedance (Z)

This value is determined by dividing the rms voltages and currents over one period.

$$Z = \frac{U_{rms}}{I_{rms}}$$

Series Resistance (RS)

This value is determined by dividing the active power over one period by the square of the rms current.

$$\frac{P}{I_{rms}^2}$$

Series Reactance (XS)

This value is determined by dividing the reactive power over one period by the square of the rms current.

$$\frac{Q}{I_{rms}^2}$$

Parallel Resistance (RP)

This value is determined by dividing the square of the rms voltage by the active power over one period.

$$\frac{U_{rms}^2}{P}$$

Parallel Reactance (XP)

This value is determined by dividing the square of the rms voltage by the reactive power over one period.

$$\frac{U_{rms}^2}{Q}$$

Three-Phase Unbalance Factor

This is determined by the following equation. The three-phase unbalance factor can be calculated only when the wiring system is set to 3P3W (3V3A), 3P4W, 3P3W→3P3W(3V3A), 3P3W(3V3A)→3P4W, or 3P4W→3P3W(3V3A).

- Three-Phase Voltage Unbalance Factor**

With respect to line voltages U_{rs} , U_{st} , and U_{tr} (rms),

$$\text{Three-phase voltage unbalance factor } K = \frac{U_2}{U_1} \times 100 \%$$

where

$$U_1 = \sqrt{\frac{1}{6}(U_{rs}^2 + U_{st}^2 + U_{tr}^2) + (2\sqrt{3})\sqrt{U_a(U_a - U_{rs})(U_a - U_{st})(U_a - U_{tr})}}$$

$$U_2 = \sqrt{\frac{1}{6}(U_{rs}^2 + U_{st}^2 + U_{tr}^2) - (2\sqrt{3})\sqrt{U_a(U_a - U_{rs})(U_a - U_{st})(U_a - U_{tr})}}$$

$$U_a = \frac{(U_{rs} + U_{st} + U_{tr})}{2}$$

- Three-Phase Current Unbalance Factor**

With respect to currents I_1 , I_2 , and I_3 (rms),

$$\text{Three-phase voltage unbalance factor } K = \frac{I_2}{I_1} \times 100 \%$$

where

$$I_1 = \sqrt{\frac{1}{6}(I_1^2 + I_2^2 + I_3^2) + (2\sqrt{3})\sqrt{I_a(I_a - I_1)(I_a - I_2)(I_a - I_3)}}$$

$$I_2 = \sqrt{\frac{1}{6}(I_1^2 + I_2^2 + I_3^2) - (2\sqrt{3})\sqrt{I_a(I_a - I_1)(I_a - I_2)(I_a - I_3)}}$$

$$I_a = \frac{(I_1 + I_2 + I_3)}{2}$$

Appendix

The three-phase unbalance factor is calculated by determining the rms values from the following values for each sample for each wiring system.

	3P3W (3V3A)	3P4W	3P3W→ 3P3W (3V3A)	3P3W(3V3A)→ 3P4W	3P4W→ 3P3W (3V3A)
Urs	u1	u1-u2	u1	u1	u1-u2
Ust	u2	u2-u3	u2	u2	u2-u3
Utr	u3	u3-u1	u1-u2	u3	u3-u1
I1	i1	i1	i1	i1	i1
I2	i2	i2	i2	i2	i2
I3	i3	i3	i3	i3	i3

Motor Efficiency

This value is determined by dividing the rotating speed by the total active power.

$$\eta = \frac{P_m}{P_\Sigma} \times 100\%$$

Integration time

This is the time from integration start to integration stop.

Power Analysis Equations (Wiring Unit Σ)

Measurement Function (Σ Function)	Equation			
	Single-Phase Three-Wire (1P3W)	Three-Phase Three-Wire (3P3W)	Three-Voltage Three-Current Method (3V3A)	Three-Phase Four-Wire (3P4W)
Power analysis				
U [V]	Urms Σ	$(U_{rms1} + U_{rms2}) / 2$	$(U_{rms1} + U_{rms2} + U_{rms3}) / 3$	
	Umn Σ	$(U_{mn1} + U_{mn2}) / 2$	$(U_{mn1} + U_{mn2} + U_{mn3}) / 3$	
	Udc Σ	$(U_{dc1} + U_{dc2}) / 2$	$(U_{dc1} + U_{dc2} + U_{dc3}) / 3$	
	Uac Σ	$(U_{ac1} + U_{ac2}) / 2$	$(U_{ac1} + U_{ac2} + U_{ac3}) / 3$	
Harmonic analysis				
U Σ	$(U1 + U2) / 2$		$(U1 + U2 + U3) / 3$	
Power analysis				
I [A]	Irms Σ	$(I_{rms1} + I_{rms2}) / 2$	$(I_{rms1} + I_{rms2} + I_{rms3}) / 3$	
	Imn Σ	$(I_{mn1} + I_{mn2}) / 2$	$(I_{mn1} + I_{mn2} + I_{mn3}) / 3$	
	Idc Σ	$(I_{dc1} + I_{dc2}) / 2$	$(I_{dc1} + I_{dc2} + I_{dc3}) / 3$	
	Iac Σ	$(I_{ac1} + I_{ac2}) / 2$	$(I_{ac1} + I_{ac2} + I_{ac3}) / 3$	
Harmonic analysis				
I Σ	$(I1 + I2) / 2$		$(I1 + I2 + I3) / 3$	
P Σ [W]		$P1 + P2$		$P1 + P2 + P3$
Power analysis				
S Σ [VA]	$S1 + S2$	$\frac{\sqrt{3}}{2}(S1 + S2)$	$\frac{\sqrt{3}}{3}(S1 + S2 + S3)$	$S1 + S2 + S3$
	Harmonic analysis			
		$\sqrt{P\Sigma^2 + Q\Sigma^2}$		
Power analysis				
Q Σ [var]		$\sqrt{S\Sigma^2 - P\Sigma^2}$		
	Harmonic analysis			
		$Q1 + Q2$		$Q1 + Q2 + Q3$
$\lambda\Sigma$		$\frac{P\Sigma}{S\Sigma}$		
$\varphi\Sigma$ [°]		$\cos^{-1}\left(\frac{P\Sigma}{S\Sigma}\right)$ (only for power analysis)		
Z Σ [Ω]		$\frac{S\Sigma}{I_{rms\Sigma}^2}$ (only for power analysis)		
R Σ [Ω]		$\frac{P\Sigma}{I_{rms\Sigma}^2}$ (only for power analysis)		
X Σ [Ω]		$\frac{Q\Sigma}{I_{rms\Sigma}^2}$ (only for power analysis)		
R $P\Sigma$ [Ω] (= 1/G)		$\frac{U_{rms\Sigma}^2}{P\Sigma}$ (only for power analysis)		
X $P\Sigma$ [Ω] (= 1/B)		$\frac{U_{rms\Sigma}^2}{Q\Sigma}$ (only for power analysis)		
η (efficiency 1) [%]		$\frac{P\Sigma B}{P\Sigma A} \cdot 100$ (only for power analysis)		
$1/\eta$ (efficiency 2) [%]		$\frac{P\Sigma A}{P\Sigma B} \cdot 100$ (only for power analysis)		



- P Σ , Q Σ , and $\lambda\Sigma$ are equations that apply both to power analysis and harmonic analysis.
- Each symbol denotes the measurement function of each source channel that is determined during power analysis or harmonic analysis.
- The letters A and B of ΣA and ΣB denote the combinations of wiring systems.
- A represents Wiring System1, and B represents Wiring System2.

Harmonic Analysis Equations

(Table 1/2)

Measurement Function	Methods of Determination and Equation	
	Harmonic measurement of measurement function	Total {() none }
Voltage Vrms [V]	$U(k) = \sqrt{u_r(k)^2 + u_j(k)^2}$	$U = \sqrt{\sum_{k=1}^{\max} U(k)^2}$
Current Irms [A]	$I(k) = \sqrt{i_r(k)^2 + i_j(k)^2}$	$I = \sqrt{\sum_{k=1}^{\max} I(k)^2}$
Active power P [W]	$P(k) = u_r(k) \cdot i_r(k) + u_j(k) \cdot i_j(k)$	$P = \sum_{k=1}^{\max} P(k)$
Apparent power S [VA]	—	$S = \sqrt{P^2 + Q^2}$
Reactive power Q [var]	$Q(k) = u_r(k) \cdot i_r(k) - u_j(k) \cdot i_j(k)$	$Q = \sum_{k=1}^{\max} Q(k)$
Power factor λ	—	$\lambda = \frac{P}{S}$
Phase angle φ [°]	$\varphi(k) = (\text{nth harmonic phase}) - (\text{fundamental phase}) \times k$ When the source is voltage in Line RMS mode, $\tan^{-1}\left\{\frac{u_r(k)}{u_j(k)}\right\} - \tan^{-1}\left\{\frac{u_r(1)}{u_j(1)}\right\} \times k$ When the source is current in Line RMS mode, $\tan^{-1}\left\{\frac{i_r(k)}{i_j(k)}\right\} - \tan^{-1}\left\{\frac{i_r(1)}{i_j(1)}\right\} \times k$ When Power mode, $\tan^{-1}\left\{\frac{Q_r(k)}{P_j(k)}\right\} - \tan^{-1}\left\{\frac{Q_r(1)}{P_j(1)}\right\} \times k$	—
Harmonic distortion factor (IEC) THDIEC	Calculates the ratio of the total rms value from the 2nd to the 40th harmonic to the fundamental wave. $\text{Distortion factor (IEC)} = \sqrt{\frac{\sum_{n=2}^{40} (\text{nth harmonic rms voltage (or current)})^2}{(\text{fundamental rms voltage (or current)})^2}}$	
Harmonic distortion factor (CSA) THDCSA	Calculates the ratio of the total rms value from the 2nd to the 40th harmonic to the total rms value from the fundamental to the 40th harmonic. $\text{Distortion factor (CSA)} = \sqrt{\frac{\sum_{n=2}^{40} (\text{nth harmonic rms voltage (or current)})^2}{\sum_{n=1}^{40} (\text{nth harmonic rms voltage (or current)})^2}}$	



- k denotes a harmonic order, r denotes the real part, and j denotes the imaginary part.
- max is 40 when the analysis mode is Line RMS and 35 when it is Power.

(Table 2/2)

Measurement Function	Methods of Determination and Equation
	Harmonic order of measurement function
Harmonic voltage distortion factor U _{hdf} [%]	$\frac{U(k)}{U(1)} \cdot 100$
Harmonic current distortion factor I _{hdf} [%]	$\frac{I(k)}{I(1)} \cdot 100$
Harmonic active power distortion factor P _{hdf} [%]	$\frac{P(k)}{P(1)} \cdot 100$



k denotes a harmonic order.

Power Analysis Equations (Delta Math)

Computed results are determined by substituting all of the sampled data in the table into the equations for voltage U and current I.* The synchronization source used in delta computation is the same source as the source of the first source channel (the input element with the smallest number) in the wiring unit that is subject to delta computation.

	Delta Math Type $\varphi\Sigma$ [°]	Substituted Sampled Data		Data Determined by Delta Math and Examples of Measurement Functions and Symbols		Notes
		u (t)	i (t)			
Delta Function	3P3W→3V3A	u1– u2	– i1– i2	Unmeasured line current calculated in a three-phase three-wire system	Urms1, Umn1, Udc1, Uac1 Irms1, Imn1, Idc1, Iac1	Assumption i1+i2+i3=0
	Delta→Star	$u1 - \frac{(u1+u2)}{3}$	– – – –	Phase voltage calculated in a three-phase t hree-wire (3V3A) system	Urms1, Umn1, Udc1, Uac1	Assumption Calculated on the assumption that the center of the delta connection is the center of the star connection.
		$u2 - \frac{(u1+u2)}{3}$	– – – –		Urms2, Umn2, Udc2, Uac2	
		$u3 - \frac{(u1+u2)}{3}$	– – – –		Urms3, Umn3, Udc3, Uac3	
		– – – –	i1+i2+i3	Neutral line current	In	
	Star→Delta	u1–u2	– – – –	Line voltage calculated in a three-phase four-wire system	Urms1, Umn1, Udc1, Uac1	– – – –
		u2–u3	– – – –		Urms2, Umn2, Udc2, Uac2	
		u3–u1	– – – –		Urms3, Umn3, Udc3, Uac3	
– – – –		i1+i2+i3	Neutral line current	In		

* Equations for voltage U and current I for “Power Analysis Equation (For Each Source Channel)”



u1, u2, and u3 represent the sampled voltage data of source channel 1, 2, and 3, respectively. i1, i2, and i3 represent the sampled current data of source channel 1, 2, and 3, respectively.

Power Math Measurement Functions

Power Analysis (Power)

When the Analysis Mode is 1Wiring System

Channels/ Sub channels	Symbol	Math Item	Supported Wiring Systems							
			1P2W	1P3W	3P3W	3P3W (3V3A)	3P4W	3P3W (3P3W->3V3A)	3V3A→3P4W (Delta->Star)	3P4W→3V3A (Star->Delta)
RTmath13_1	UrmsΣ	Rms voltage		Yes	Yes	Yes	Yes	Yes	Yes	Yes
RTmath13_2	Urms1	Each rms voltage	Yes	Yes	Yes	Yes	Yes	Yes	Yes	Yes
RTmath13_3	Urms2	Each rms voltage		Yes	Yes	Yes	Yes	Yes	Yes	Yes
RTmath13_4	Urms3	Each rms voltage				Yes	Yes	Yes	Yes	Yes
RTmath13_5	IrmsΣ	Rms current		Yes	Yes	Yes	Yes	Yes	Yes	Yes
RTmath13_6	Irms1	Each rms current	Yes	Yes	Yes	Yes	Yes	Yes	Yes	Yes
RTmath13_7	Irms2	Each rms current		Yes	Yes	Yes	Yes	Yes	Yes	Yes
RTmath13_8	Irms3	Each rms current				Yes	Yes	Yes	Yes	Yes
RTmath13_9	UdcΣ	Voltage simple average (DC)		Yes	Yes	Yes	Yes	Yes	Yes	Yes
RTmath13_10	Udc1	Voltage simple average (DC)	Yes	Yes	Yes	Yes	Yes	Yes	Yes	Yes
RTmath13_11	Udc2	Voltage simple average (DC)		Yes	Yes	Yes	Yes	Yes	Yes	Yes
RTmath13_12	Udc3	Voltage simple average (DC)				Yes	Yes	Yes	Yes	Yes
RTmath13_13	IdcΣ	Current simple average (DC)		Yes	Yes	Yes	Yes	Yes	Yes	Yes
RTmath13_14	Idc1	Current simple average (DC)	Yes	Yes	Yes	Yes	Yes	Yes	Yes	Yes
RTmath13_15	Idc2	Current simple average (DC)		Yes	Yes	Yes	Yes	Yes	Yes	Yes
RTmath13_16	Idc3	Current simple average (DC)				Yes	Yes	Yes	Yes	Yes
RTmath13_17	UacΣ	Voltage AC component (AC)		Yes	Yes	Yes	Yes	Yes	Yes	Yes
RTmath13_18	Uac1	Voltage AC component (AC)	Yes	Yes	Yes	Yes	Yes	Yes	Yes	Yes
RTmath13_19	Uac2	Voltage AC component (AC)		Yes	Yes	Yes	Yes	Yes	Yes	Yes
RTmath13_20	Uac3	Voltage AC component (AC)				Yes	Yes	Yes	Yes	Yes
RTmath13_21	IacΣ	Current AC component (AC)		Yes	Yes	Yes	Yes	Yes	Yes	Yes
RTmath13_22	Iac1	Current AC component (AC)	Yes	Yes	Yes	Yes	Yes	Yes	Yes	Yes
RTmath13_23	Iac2	Current AC component (AC)		Yes	Yes	Yes	Yes	Yes	Yes	Yes
RTmath13_24	Iac3	Current AC component (AC)				Yes	Yes	Yes	Yes	Yes
RTmath13_25	PΣ	Active power P		Yes	Yes	Yes	Yes	Yes	Yes	Yes
RTmath13_26	P1	Active power P	Yes	Yes	Yes	Yes	Yes	Yes	Yes	Yes
RTmath13_27	P2	Active power P		Yes	Yes	Yes	Yes	Yes	Yes	Yes
RTmath13_28	P3	Active power P				Yes	Yes	Yes	Yes	Yes
RTmath13_29	SΣ	Apparent power S		Yes	Yes	Yes	Yes	Yes	Yes	Yes
RTmath13_30	S1	Apparent power S	Yes	Yes	Yes	Yes	Yes	Yes	Yes	Yes
RTmath13_31	S2	Apparent power S		Yes	Yes	Yes	Yes	Yes	Yes	Yes
RTmath13_32	S3	Apparent power S				Yes	Yes	Yes	Yes	Yes
RTmath13_33	QΣ	Reactive power Q		Yes	Yes	Yes	Yes	Yes	Yes	Yes
RTmath13_34	Q1	Reactive power Q	Yes	Yes	Yes	Yes	Yes	Yes	Yes	Yes
RTmath13_35	Q2	Reactive power Q		Yes	Yes	Yes	Yes	Yes	Yes	Yes
RTmath13_36	Q3	Reactive power Q				Yes	Yes	Yes	Yes	Yes
RTmath13_37	λΣ	Power factor		Yes	Yes	Yes	Yes	Yes	Yes	Yes

Channels/ Sub channels	Symbol	Math Item	Supported Wiring Systems							
			1P2W	1P3W	3P3W	3P3W (3V3A)	3P4W	3P3W (3P3W→3V3A)	3V3A→3P4W (Delta→Star)	3P4W→3V3A (Star→Delta)
RTmath13_38	$\lambda 1$	Each power factor	Yes	Yes	Yes	Yes	Yes	Yes	Yes	Yes
RTmath13_39	$\lambda 2$	Each power factor		Yes	Yes	Yes	Yes	Yes	Yes	Yes
RTmath13_40	$\lambda 3$	Each power factor				Yes	Yes	Yes	Yes	Yes
RTmath13_41	$\Phi\Sigma$	Phase angle		Yes	Yes	Yes	Yes	Yes	Yes	Yes
RTmath13_42	$\Phi 1$	Phase angle	Yes	Yes	Yes	Yes	Yes	Yes	Yes	Yes
RTmath13_43	$\Phi 2$	Phase angle		Yes	Yes	Yes	Yes	Yes	Yes	Yes
RTmath13_44	$\Phi 3$	Phase angle				Yes	Yes	Yes	Yes	Yes
RTmath13_45	fU1	Voltage frequency	Yes	Yes	Yes	Yes	Yes	Yes	Yes	Yes
RTmath13_46	fU2	Voltage frequency		Yes	Yes	Yes	Yes	Yes	Yes	Yes
RTmath13_47	fU3	Voltage frequency				Yes	Yes	Yes	Yes	Yes
RTmath13_48	fI1	Current frequency	Yes	Yes	Yes	Yes	Yes	Yes	Yes	Yes
RTmath13_49	fI2	Current frequency		Yes	Yes	Yes	Yes	Yes	Yes	Yes
RTmath13_50	fI3	Current frequency				Yes	Yes	Yes	Yes	Yes
RTmath13_51	U+pk1	Maximum voltage	Yes	Yes	Yes	Yes	Yes	Yes	Yes	Yes
RTmath13_52	U-pk1	Minimum voltage	Yes	Yes	Yes	Yes	Yes	Yes	Yes	Yes
RTmath13_53	U+pk2	Maximum voltage		Yes	Yes	Yes	Yes	Yes	Yes	Yes
RTmath13_54	U-pk2	Minimum voltage		Yes	Yes	Yes	Yes	Yes	Yes	Yes
RTmath13_55	U+pk3	Maximum voltage				Yes	Yes	Yes	Yes	Yes
RTmath13_56	U-pk3	Minimum voltage				Yes	Yes	Yes	Yes	Yes
RTmath13_57	I+pk1	Maximum current	Yes	Yes	Yes	Yes	Yes	Yes	Yes	Yes
RTmath13_58	I-pk1	Minimum current	Yes	Yes	Yes	Yes	Yes	Yes	Yes	Yes
RTmath13_59	I+pk2	Maximum current		Yes	Yes	Yes	Yes	Yes	Yes	Yes
RTmath13_60	I-pk2	Minimum current		Yes	Yes	Yes	Yes	Yes	Yes	Yes
RTmath14_1	I+pk3	Maximum current				Yes	Yes	Yes	Yes	Yes
RTmath14_2	I-pk3	Minimum current				Yes	Yes	Yes	Yes	Yes
RTmath14_3	P+pk1	Maximum power	Yes	Yes	Yes	Yes	Yes	Yes	Yes	Yes
RTmath14_4	P-pk1	Minimum power	Yes	Yes	Yes	Yes	Yes	Yes	Yes	Yes
RTmath14_5	P+pk2	Maximum power		Yes	Yes	Yes	Yes	Yes	Yes	Yes
RTmath14_6	P-pk2	Minimum power		Yes	Yes	Yes	Yes	Yes	Yes	Yes
RTmath14_7	P+pk3	Maximum power				Yes	Yes	Yes	Yes	Yes
RTmath14_8	P-pk3	Minimum power				Yes	Yes	Yes	Yes	Yes
RTmath14_9	WPΣ	Integrated power		Yes	Yes	Yes	Yes	Yes	Yes	Yes
RTmath14_10	WP1	Integrated power	Yes	Yes	Yes	Yes	Yes	Yes	Yes	Yes
RTmath14_11	WP2	Integrated power		Yes	Yes	Yes	Yes	Yes	Yes	Yes
RTmath14_12	WP3	Integrated power				Yes	Yes	Yes	Yes	Yes
RTmath14_13	WP+Σ	Integrated power		Yes	Yes	Yes	Yes	Yes	Yes	Yes
RTmath14_14	WP+1	Integrated power	Yes	Yes	Yes	Yes	Yes	Yes	Yes	Yes
RTmath14_15	WP+2	Integrated power		Yes	Yes	Yes	Yes	Yes	Yes	Yes
RTmath14_16	WP+3	Integrated power				Yes	Yes	Yes	Yes	Yes
RTmath14_17	WP-Σ	Integrated power		Yes	Yes	Yes	Yes	Yes	Yes	Yes
RTmath14_18	WP-1	Integrated power	Yes	Yes	Yes	Yes	Yes	Yes	Yes	Yes
RTmath14_19	WP-2	Integrated power		Yes	Yes	Yes	Yes	Yes	Yes	Yes
RTmath14_20	WP-3	Integrated power				Yes	Yes	Yes	Yes	Yes
RTmath14_21	qΣ	Integrated ampere-hour		Yes	Yes	Yes	Yes	Yes	Yes	Yes
RTmath14_22	q1	Integrated ampere-hour	Yes	Yes	Yes	Yes	Yes	Yes	Yes	Yes
RTmath14_23	q2	Integrated ampere-hour		Yes	Yes	Yes	Yes	Yes	Yes	Yes
RTmath14_24	q3	Integrated ampere-hour				Yes	Yes	Yes	Yes	Yes
RTmath14_25	q+Σ	Integrated ampere-hour		Yes	Yes	Yes	Yes	Yes	Yes	Yes

Appendix

Channels/ Sub channels	Symbol	Math Item	Supported Wiring Systems							
			1P2W	1P3W	3P3W	3P3W (3V3A)	3P4W	3P3W (3P3W->3V3A)	3V3A→3P4W (Delta->Star)	3P4W→3V3A (Star->Delta)
RTmath14_26	q+1	Integrated ampere-hour	Yes	Yes	Yes	Yes	Yes	Yes	Yes	Yes
RTmath14_27	q+2	Integrated ampere-hour		Yes	Yes	Yes	Yes	Yes	Yes	Yes
RTmath14_28	q+3	Integrated ampere-hour				Yes	Yes	Yes	Yes	Yes
RTmath14_29	q-Σ	Integrated ampere-hour		Yes	Yes	Yes	Yes	Yes	Yes	Yes
RTmath14_30	q-1	Integrated ampere-hour	Yes	Yes	Yes	Yes	Yes	Yes	Yes	Yes
RTmath14_31	q-2	Integrated ampere-hour		Yes	Yes	Yes	Yes	Yes	Yes	Yes
RTmath14_32	q-3	Integrated ampere-hour				Yes	Yes	Yes	Yes	Yes
RTmath14_33	WSΣ	Volt-ampere hours		Yes	Yes	Yes	Yes	Yes	Yes	Yes
RTmath14_34	WS1	Volt-ampere hours WS	Yes	Yes	Yes	Yes	Yes	Yes	Yes	Yes
RTmath14_35	WS2	Volt-ampere hours		Yes	Yes	Yes	Yes	Yes	Yes	Yes
RTmath14_36	WS3	Volt-ampere hours				Yes	Yes	Yes	Yes	Yes
RTmath14_37	WQΣ	Var hours		Yes	Yes	Yes	Yes	Yes	Yes	Yes
RTmath14_38	WQ1	Var hours WQ	Yes	Yes	Yes	Yes	Yes	Yes	Yes	Yes
RTmath14_39	WQ2	Var hours		Yes	Yes	Yes	Yes	Yes	Yes	Yes
RTmath14_40	WQ3	Var hours				Yes	Yes	Yes	Yes	Yes
RTmath14_41	ZΣ	Load circuit impedance		Yes	Yes	Yes	Yes	Yes	Yes	Yes
RTmath14_42	Z1	Load circuit impedance	Yes	Yes	Yes	Yes	Yes	Yes	Yes	Yes
RTmath14_43	Z2	Load circuit impedance		Yes	Yes	Yes	Yes	Yes	Yes	Yes
RTmath14_44	Z3	Load circuit impedance				Yes	Yes	Yes	Yes	Yes
RTmath14_45	RSΣ	Load circuit series resistance¹		Yes	Yes	Yes	Yes	Yes	Yes	Yes
RTmath14_46	RS1	Load circuit series resistance ¹	Yes	Yes	Yes	Yes	Yes	Yes	Yes	Yes
RTmath14_47	RS2	Load circuit series resistance ¹		Yes	Yes	Yes	Yes	Yes	Yes	Yes
RTmath14_48	RS3	Load circuit series resistance ¹				Yes	Yes	Yes	Yes	Yes
RTmath14_49	XΣ	Load circuit series reactance¹		Yes	Yes	Yes	Yes	Yes	Yes	Yes
RTmath14_50	XS1	Load circuit series reactance ¹	Yes	Yes	Yes	Yes	Yes	Yes	Yes	Yes
RTmath14_51	XS2	Load circuit series reactance ¹		Yes	Yes	Yes	Yes	Yes	Yes	Yes
RTmath14_52	XS3	Load circuit series reactance ¹				Yes	Yes	Yes	Yes	Yes
RTmath14_45	RPΣ	Load circuit parallel resistance²		Yes	Yes	Yes	Yes	Yes	Yes	Yes
RTmath14_46	RP1	Load circuit parallel resistance ²	Yes	Yes	Yes	Yes	Yes	Yes	Yes	Yes
RTmath14_47	RP2	Load circuit parallel resistance ²		Yes	Yes	Yes	Yes	Yes	Yes	Yes
RTmath14_48	RP3	Load circuit parallel resistance ²				Yes	Yes	Yes	Yes	Yes
RTmath14_49	XPΣ	Load circuit parallel reactance²		Yes	Yes	Yes	Yes	Yes	Yes	Yes
RTmath14_50	XP1	Load circuit parallel reactance ²	Yes	Yes	Yes	Yes	Yes	Yes	Yes	Yes

Channels/ Sub channels	Symbol	Math Item	Supported Wiring Systems							
			1P2W	1P3W	3P3W	3P3W (3V3A)	3P4W	3P3W (3P3W→3V3A)	3V3A→3P4W (Delta→Star)	3P4W→3V3A (Star→Delta)
RTmath14_51	XP2	Load circuit parallel reactance ²		Yes	Yes	Yes	Yes	Yes	Yes	Yes
RTmath14_52	XP3	Load circuit parallel reactance ²				Yes	Yes	Yes	Yes	Yes
RTmath14_53	Pm	Motor output (drive efficiency)	Yes	Yes	Yes	Yes	Yes	Yes	Yes	Yes
RTmath14_54	η	Efficiency	Yes	Yes	Yes	Yes	Yes	Yes	Yes	Yes
RTmath14_55	Uubf	Three-Phase Voltage Unbalance Factor				Yes	Yes	Yes	Yes	Yes
RTmath14_56	Iubf	Three-Phase Current Unbalance Factor				Yes	Yes	Yes	Yes	Yes
RTmath14_57	In	Neutral line current				Yes	Yes	Yes	Yes	Yes
RTmath14_58	Time	Integration time	Yes	Yes	Yes	Yes	Yes	Yes	Yes	Yes

- 1 When the load circuit connection type in Analysis Setting is Series
- 2 When the load circuit connection type in Analysis Setting is Parallel

Appendix

When the Analysis Mode is 2Wiring Systems

Channels/Sub channels		Symbol	Math Item	Supported Wiring Systems							
Wiring System1	Wiring System2			1P2W	1P3W	3P3W	3P3W (3V3A)	3P4W	3P3W (3P3W->3V3A)	3V3A→3P4W (Delta->Star)	3P4W→3V3A (Star->Delta)
RTmath13_1	RTmath14_1	$U_{rms\Sigma}$	Rms voltage		Yes	Yes	Yes	Yes	Yes	Yes	Yes
RTmath13_2	RTmath14_2	Urms1	Each rms voltage	Yes	Yes	Yes	Yes	Yes	Yes	Yes	Yes
RTmath13_3	RTmath14_3	Urms2	Each rms voltage		Yes	Yes	Yes	Yes	Yes	Yes	Yes
RTmath13_4	RTmath14_4	Urms3	Each rms voltage				Yes	Yes	Yes	Yes	Yes
RTmath13_5	RTmath14_5	$I_{rms\Sigma}$	Rms current		Yes	Yes	Yes	Yes	Yes	Yes	Yes
RTmath13_6	RTmath14_6	Irms1	Each rms current	Yes	Yes	Yes	Yes	Yes	Yes	Yes	Yes
RTmath13_7	RTmath14_7	Irms2	Each rms current		Yes	Yes	Yes	Yes	Yes	Yes	Yes
RTmath13_8	RTmath14_8	Irms3	Each rms current				Yes	Yes	Yes	Yes	Yes
RTmath13_9	RTmath14_9	$U_{dc\Sigma}$	Voltage simple average (DC)		Yes	Yes	Yes	Yes	Yes	Yes	Yes
RTmath13_10	RTmath14_10	$I_{dc\Sigma}$	Current simple average (DC)		Yes	Yes	Yes	Yes	Yes	Yes	Yes
RTmath13_11	RTmath14_11	$U_{ac\Sigma}$	Voltage AC component (AC)		Yes	Yes	Yes	Yes	Yes	Yes	Yes
RTmath13_12	RTmath14_12	$I_{ac\Sigma}$	Current AC component (AC)		Yes	Yes	Yes	Yes	Yes	Yes	Yes
RTmath13_13	RTmath14_13	$P\Sigma$	Active power P		Yes	Yes	Yes	Yes	Yes	Yes	Yes
RTmath13_14	RTmath14_14	$S\Sigma$	Apparent power S		Yes	Yes	Yes	Yes	Yes	Yes	Yes
RTmath13_15	RTmath14_15	$Q\Sigma$	Reactive power Q		Yes	Yes	Yes	Yes	Yes	Yes	Yes
RTmath13_16	RTmath14_16	$\lambda\Sigma$	Power factor		Yes	Yes	Yes	Yes	Yes	Yes	Yes
RTmath13_17	RTmath14_17	$\Phi\Sigma$	Phase angle		Yes	Yes	Yes	Yes	Yes	Yes	Yes
RTmath13_18	RTmath14_18	fU1	Voltage frequency	Yes	Yes	Yes	Yes	Yes	Yes	Yes	Yes
RTmath13_19	RTmath14_19	fU2	Voltage frequency		Yes	Yes	Yes	Yes	Yes	Yes	Yes
RTmath13_20	RTmath14_20	fU3	Voltage frequency				Yes	Yes	Yes	Yes	Yes
RTmath13_21	RTmath14_21	fI1	Current frequency	Yes	Yes	Yes	Yes	Yes	Yes	Yes	Yes
RTmath13_22	RTmath14_22	fI2	Current frequency		Yes	Yes	Yes	Yes	Yes	Yes	Yes
RTmath13_23	RTmath14_23	fI3	Current frequency				Yes	Yes	Yes	Yes	Yes
RTmath13_24	RTmath14_24	U+pk1	Maximum voltage	Yes	Yes	Yes	Yes	Yes	Yes	Yes	Yes
RTmath13_25	RTmath14_25	U-pk1	Minimum voltage	Yes	Yes	Yes	Yes	Yes	Yes	Yes	Yes
RTmath13_26	RTmath14_26	U+pk2	Maximum voltage		Yes	Yes	Yes	Yes	Yes	Yes	Yes
RTmath13_27	RTmath14_27	U-pk2	Minimum voltage		Yes	Yes	Yes	Yes	Yes	Yes	Yes
RTmath13_28	RTmath14_28	U+pk3	Maximum voltage				Yes	Yes	Yes	Yes	Yes
RTmath13_29	RTmath14_29	U-pk3	Minimum voltage				Yes	Yes	Yes	Yes	Yes
RTmath13_30	RTmath14_30	I+pk1	Maximum current	Yes	Yes	Yes	Yes	Yes	Yes	Yes	Yes
RTmath13_31	RTmath14_31	I-pk1	Minimum current	Yes	Yes	Yes	Yes	Yes	Yes	Yes	Yes
RTmath13_32	RTmath14_32	I+pk2	Maximum current		Yes	Yes	Yes	Yes	Yes	Yes	Yes
RTmath13_33	RTmath14_33	I-pk2	Minimum current		Yes	Yes	Yes	Yes	Yes	Yes	Yes
RTmath13_34	RTmath14_34	I+pk3	Maximum current				Yes	Yes	Yes	Yes	Yes
RTmath13_35	RTmath14_35	I-pk3	Minimum current				Yes	Yes	Yes	Yes	Yes
RTmath13_36	RTmath14_36	P+pk1	Maximum power	Yes	Yes	Yes	Yes	Yes	Yes	Yes	Yes
RTmath13_37	RTmath14_37	P-pk1	Minimum power	Yes	Yes	Yes	Yes	Yes	Yes	Yes	Yes

Channels/Sub channels		Symbol	Math Item	Supported Wiring Systems							
Wiring System1	Wiring System2			1P2W	1P3W	3P3W	3P3W (3V3A)	3P4W	3P3W (3P3W->3V3A)	3V3A->3P4W (Delta->Star)	3P4W->3V3A (Star->Delta)
RTmath13_38	RTmath14_38	P+pk2	Maximum power		Yes	Yes	Yes	Yes	Yes	Yes	Yes
RTmath13_39	RTmath14_39	P-pk2	Minimum power		Yes	Yes	Yes	Yes	Yes	Yes	Yes
RTmath13_40	RTmath14_40	P+pk3	Maximum power				Yes	Yes	Yes	Yes	Yes
RTmath13_41	RTmath14_41	P-pk3	Minimum power				Yes	Yes	Yes	Yes	Yes
RTmath13_42	RTmath14_42	WPΣ	Integrated power		Yes	Yes	Yes	Yes	Yes	Yes	Yes
RTmath13_43	RTmath14_43	WP+Σ	Integrated power		Yes	Yes	Yes	Yes	Yes	Yes	Yes
RTmath13_44	RTmath14_44	WP-Σ	Integrated power		Yes	Yes	Yes	Yes	Yes	Yes	Yes
RTmath13_45	RTmath14_45	qΣ	Integrated ampere-hour		Yes	Yes	Yes	Yes	Yes	Yes	Yes
RTmath13_46	RTmath14_46	q+Σ	Integrated ampere-hour		Yes	Yes	Yes	Yes	Yes	Yes	Yes
RTmath13_47	RTmath14_47	q-Σ	Integrated ampere-hour		Yes	Yes	Yes	Yes	Yes	Yes	Yes
RTmath13_48	RTmath14_48	WSΣ	Volt-ampere hours		Yes	Yes	Yes	Yes	Yes	Yes	Yes
RTmath13_49	RTmath14_49	WQΣ	Var hours		Yes	Yes	Yes	Yes	Yes	Yes	Yes
RTmath13_50	RTmath14_50	ZΣ	Load circuit Impedance		Yes	Yes	Yes	Yes	Yes	Yes	Yes
RTmath13_51	RTmath14_51	RSΣ	Load circuit series resistance ¹		Yes	Yes	Yes	Yes	Yes	Yes	Yes
RTmath13_52	RTmath14_52	XSΣ	Load circuit series Reactance ¹		Yes	Yes	Yes	Yes	Yes	Yes	Yes
RTmath13_51	RTmath14_51	RPΣ	Load circuit parallel resistance ²		Yes	Yes	Yes	Yes	Yes	Yes	Yes
RTmath13_52	RTmath14_52	XPΣ	Load circuit parallel Reactance ²		Yes	Yes	Yes	Yes	Yes	Yes	Yes
RTmath13_53	RTmath14_53	Pm	Motor output (drive efficiency)	Yes	Yes	Yes	Yes	Yes	Yes	Yes	Yes
RTmath13_54	RTmath14_54	η	Efficiency	Yes	Yes	Yes	Yes	Yes	Yes	Yes	Yes
RTmath13_55	RTmath14_55	Uubf	Three-Phase Voltage Unbalance Factor				Yes	Yes	Yes	Yes	Yes
RTmath13_56	RTmath14_56	Iubf	Three-Phase Current Unbalance Factor				Yes	Yes	Yes	Yes	Yes
RTmath13_57	RTmath14_57	In	Neutral line current				Yes	Yes	Yes	Yes	Yes
RTmath13_58	RTmath14_58	Time	Integration time	Yes	Yes	Yes	Yes	Yes	Yes	Yes	Yes

1 When the load circuit connection type in Analysis Setting is Series

2 When the load circuit connection type in Analysis Setting is Parallel

Harmonic Analysis (Harmonics)

When the analysis mode is Line RMS

Channels/Sub channels	Symbol	Math Item
RTmath15_1 to RTmath15_40	RMS	Rms value (1st to 40th harmonic)
RTmath15_41 to RTmath15_62, RTmath16_1 to RTmath16_18	Rhdf(harmonic distortion factor)	Percentage content (1st to 40th harmonic)
RTmath16_19 to RTmath16_58	Φ	Phase angle (1st to 40th harmonic)
RTmath16_59	RMS	Total rms value
RTmath16_60	THDIEC	Distortion factor (IEC)
RTmath16_61	THDCSA	Distortion factor (CSA)

When the Analysis Mode is Power

Channels/ Sub channels	Symbol	Math Item	Supported Wiring Systems							
			1P2W	1P3W	3P3W	3P3W (3V3A)	3P4W	3P3W (3P3W->3V3A)	3V3A (Delta->Star)	3P4W (Star->Delta)
RTmath15_1 to RTmath15_35	P	Effective Power (1st to 35th harmonic)	Yes	Yes	Yes	Yes	Yes	Yes	Yes	Yes
RTmath15_36 to RTmath15_62, RTmath16_1 to RTmath16_8	Phdf(harmonic distortion factor)	Active power percentage content (1st to 35th harmonic)	Yes	Yes	Yes	Yes	Yes	Yes	Yes	Yes
RTmath16_9 to RTmath16_43	Φ	Phase angle (1st to 35th harmonic)	Yes	Yes	Yes	Yes	Yes	Yes	Yes	Yes
RTmath16_44	P	Total active powers	Yes	Yes	Yes	Yes	Yes	Yes	Yes	Yes
RTmath16_45	S	Total apparent powers	Yes	Yes	Yes	Yes	Yes	Yes	Yes	Yes
RTmath16_46	Q	Total reactive powers	Yes	Yes	Yes	Yes	Yes	Yes	Yes	Yes
RTmath16_47	λ	Power factor	Yes	Yes	Yes	Yes	Yes	Yes	Yes	Yes
RTmath16_48	U1rms	1st harmonic rms voltage	Yes	Yes	Yes	Yes	Yes	Yes	Yes	Yes
RTmath16_49	I1rms	1st harmonic rms current	Yes	Yes	Yes	Yes	Yes	Yes	Yes	Yes
RTmath16_50	U2rms	1st harmonic rms voltage		Yes	Yes	Yes	Yes	Yes	Yes	Yes
RTmath16_51	I2rms	1st harmonic rms current		Yes	Yes	Yes	Yes	Yes	Yes	Yes
RTmath16_52	U3rms	1st harmonic rms voltage				Yes	Yes	Yes	Yes	Yes
RTmath16_53	I3rms	1st harmonic rms current				Yes	Yes	Yes	Yes	Yes
RTmath16_54	Φ U1-U1	1st harmonic voltage phase angle	Yes	Yes	Yes	Yes	Yes	Yes	Yes	Yes
RTmath16_55	Φ U1-I1	1st harmonic current phase angle	Yes	Yes	Yes	Yes	Yes	Yes	Yes	Yes
RTmath16_56	Φ U1-U2	1st harmonic voltage phase angle		Yes	Yes	Yes	Yes	Yes	Yes	Yes
RTmath16_57	Φ U1-I2	1st harmonic current phase angle		Yes	Yes	Yes	Yes	Yes	Yes	Yes
RTmath16_58	Φ U1-U3	1st harmonic voltage phase angle				Yes	Yes	Yes	Yes	Yes
RTmath16_59	Φ U1-I3	1st harmonic current phase angle				Yes	Yes	Yes	Yes	Yes

Appendix 13 Data Acquisition of Power Analysis Results and Harmonic Analysis Results

In power analysis and harmonic analysis, the analysis period* is from a zero crossing point to the next zero crossing point.* Calculations are performed on the data in this section, and the zero crossing time at the calculation start point and the calculation result are recorded (timestamp format). Since the calculation result is displayed based on the time of the calculation start point, it is possible to display the analysis result, the waveform data that is the basis of the calculation, and the calculation result without phase shift.

In power analysis and harmonic analysis, the data from a zero cross point to the zero cross point is analyzed. Therefore, power analysis and harmonic analysis cannot be performed for sections in which the zero cross point that corresponds to the analysis start point or the zero cross point that corresponds to the analysis end point does not remain in the waveform recording section because the analysis period is not determined. As such, power analysis result and harmonic analysis results cannot be displayed with waveforms in the range where the analysis period is not recorded.

* In power analysis, the analysis period differs depending on the type of calculation period (calc period).

If the type is edge (Edge), the analysis period is from the zero crossing point of the edge source to the zero crossing point. If the type is Timer, the analysis period is the specified update time (Auto Timer). If the type is transient (Transient), the analysis period switches when the edge and Timer switch.

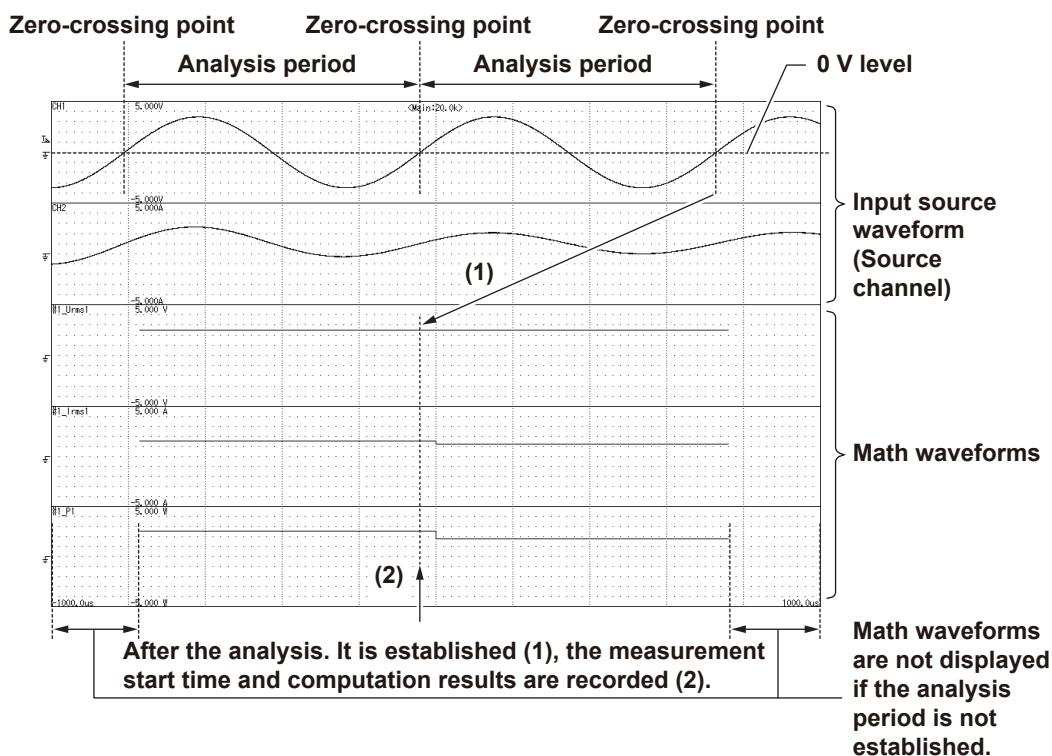

Appendix 14 Power Basics (Power, harmonics, and AC RLC circuits)

This section explains the basics of power, harmonics, and AC RLC circuits.

Power

Electrical energy can be converted into other forms of energy and used. For example, it can be converted into the heat in an electric heater, the torque in a motor, or the light in a fluorescent or mercury lamp. In these kinds of examples, the work that electricity performs in a given period of time (or the electrical energy expended) is referred to as electric power. The unit of electric power is watts (W). 1 watt is equivalent to 1 joule of work performed in 1 second.

DC Power

The DC power P (in watts) is determined by multiplying the applied voltage U (in volts) by the current I (in amps).

$$P = UI \text{ [W]}$$

In the example below, the amount of electrical energy determined by the equation above is retrieved from the power supply and consumed by resistance [Ω] (load) every second.

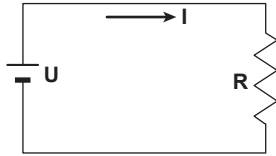

Alternating Current

Normally, the power supplied by power companies is alternating current with sinusoidal waveforms. The magnitude of alternating current can be expressed using values such as instantaneous, maximum, rms, and mean values. Normally, it is expressed using rms values.

The instantaneous value i of a sinusoidal alternating current is expressed by $I_m \sin \omega t$ (where I_m is the maximum value of the current, ω is the angular velocity defined as $\omega = 2\pi f$, and f is the frequency of the sinusoidal alternating current). The thermal action of this alternating current is proportional to i^2 , and varies as shown in the figure below.*

* Thermal action is the phenomenon in which electric energy is converted to heat energy when a current flows through a resistance.

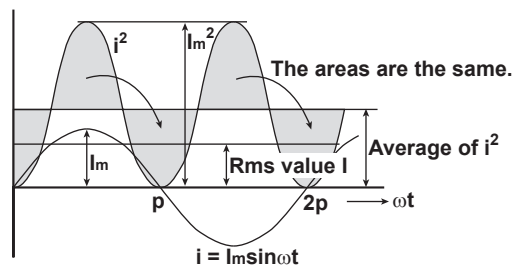

The rms value (effective value) is the DC value that generates the same thermal action as the alternating current. With I as the DC value that produces the same thermal action as the alternating current:

$$I = \sqrt{\text{The mean of } i^2 \text{ over one period}} = \sqrt{\frac{1}{2\pi} \int_0^{2\pi} i^2 d\omega t} = \frac{I_m}{\sqrt{2}}$$

Because this value corresponds to the root mean square of the instantaneous values over 1 period, the effective value is normally denoted using the abbreviation "rms."

To determine the mean value, the average is taken over 1 period of absolute values, because simply taking the average over 1 period of the sine wave results in a value of zero. With I_{mn} as the mean value of the instantaneous current i (which is equal to $I_m \sin \omega t$):

$$I_{mn} = \text{The mean of } |i| \text{ over one period} = \frac{1}{2\pi} \int_0^{2\pi} |i| d\omega t = \frac{2}{\pi} I_m$$

These relationships also apply to sinusoidal voltages.

The maximum value, rms value, and mean value of a sinusoidal alternating current are related as shown below. The crest factor and form factor are used to define the tendency of an AC waveform.

$$\text{Crest factor} = \frac{\text{Maximum value}}{\text{Rms value}}$$

$$\text{Form factor} = \frac{\text{Rms value}}{\text{Mean value}}$$

Vector Display of Alternating Current

In general, instantaneous voltage and current values are expressed using the equations listed below.

$$\text{Voltage: } u = U_m \sin \omega t$$

$$\text{Current: } i = I_m \sin(\omega t - \phi)$$

The time offset between the voltage and current is called the phase difference, and ϕ is the phase angle.

The time offset is mainly caused by the load that the power is supplied to. In general, the phase difference is zero when the load is purely resistive. The current lags the voltage when the load is inductive (is coiled). The current leads the voltage when the load is capacitive.

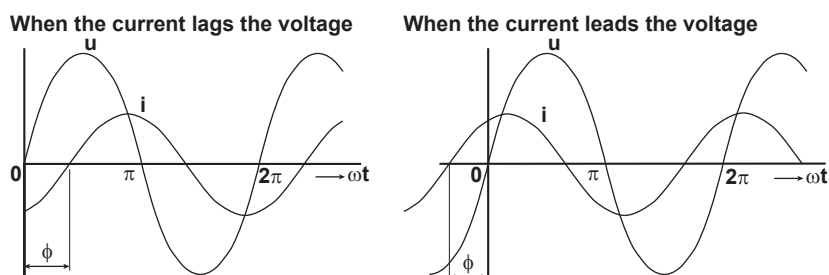

A vector display is used to clearly convey the magnitude and phase relationships between the voltage and current. A positive phase angle is represented by a counterclockwise angle with respect to the vertical axis. Normally, a dot is placed above the symbol representing a quantity to explicitly indicate that it is a vector. The magnitude of a vector represents the rms value.

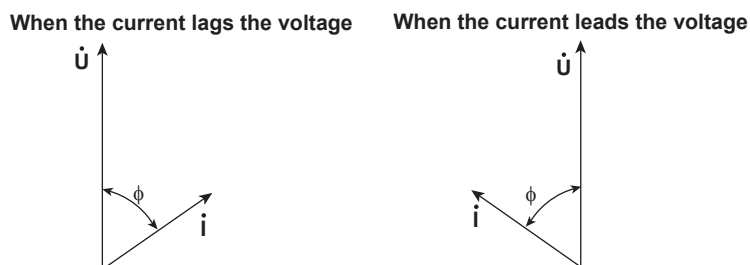

Three-Phase AC Wiring

Generally three-phase AC power lines or loads are connected in star wiring configurations or delta wiring configurations.

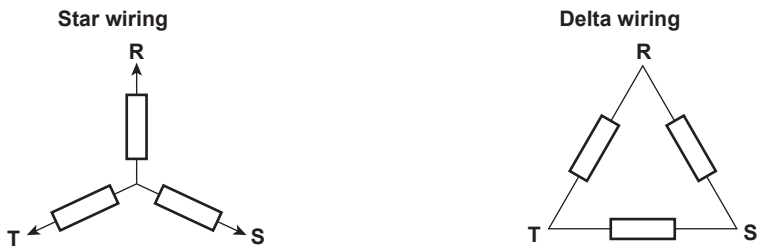

Vector Display of Three-Phase Alternating Current

In typical three-phase AC power, the voltage of each phase is offset by 120°. The figure below expresses this offset using vectors. The voltage of each phase is called the phase voltage, and the voltage between each phase is called the line voltage.

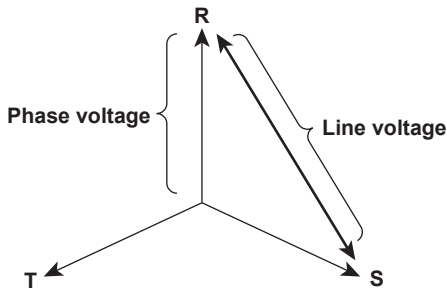

If a power supply or load is connected in a delta wiring configuration and no neutral line is present, the phase voltage cannot be measured. In this case, the line voltage is measured. Sometimes the line voltage is also measured when measuring three-phase AC power using two single-phase wattmeters (the two-wattmeter method). If the magnitude of each phase voltage is equal and each phase is offset by 120°, the magnitude of the line voltage is $\sqrt{3}$ times the magnitude of the phase voltage, and the line voltage phase is offset by 30°.

Below is a vector representation of the relationship between the phase voltages and line currents of a three-phase AC voltage when the current lags the voltage by ϕ° .

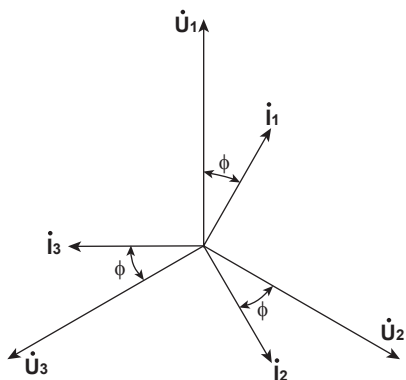

AC Power

AC power cannot be determined as easily as DC power, because of the phase difference between the voltage and current caused by load.

If the instantaneous voltage $u = U_m \sin \omega t$ and the instantaneous current $i = I_m \sin(\omega t - \Phi)$, the instantaneous AC power p is as follows:

$$p = u \times i = U_m \sin \omega t \times I_m \sin(\omega t - \Phi) = UI \cos \Phi - UI \cos(2\omega t - \Phi)$$

U and I represent the rms voltage and rms current, respectively.

p is the sum of the time-independent term, $UI \cos \Phi$, and the AC component term of the voltage or current at twice the frequency, $-UI \cos(2\omega t - \Phi)$.

AC power refers to the mean power over 1 period. When the mean over 1 period is taken, AC power P is as follows:

$$P = UI \cos \phi \text{ [W]}$$

Even if the voltage and current are the same, the power varies depending on the phase difference Φ . The section above the horizontal axis in the figure below represents positive power (power supplied to the load), and the section below the axis represents negative power (power fed back from the load). The difference between the positive and negative powers is the power consumed by the load. As the phase difference between the voltage and current increases, the negative power increases. At $\Phi = \pi/2$, the positive and negative powers are equal, and the load consumes no power.

When the phase difference between voltage and current is 0

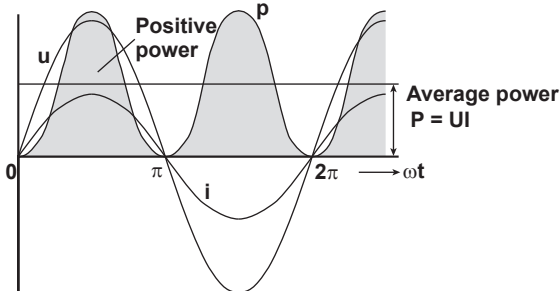

When the phase difference between voltage and current is ϕ

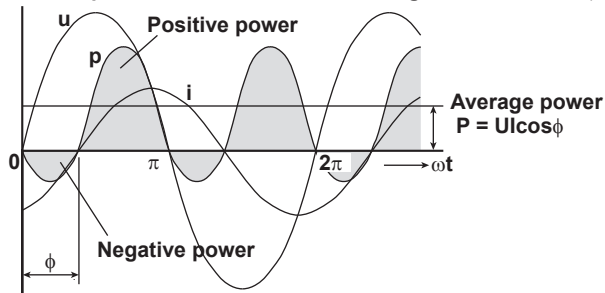

When phase difference between voltage and current is $\frac{\pi}{2}$

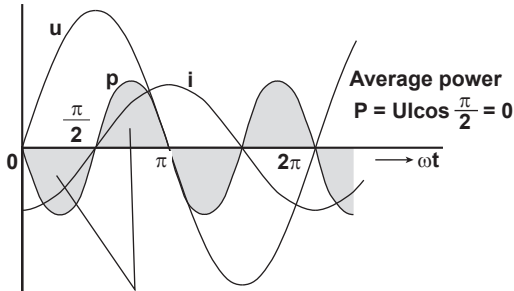

The positive and negative powers are the same.

Active Power and the Power Factor

In alternating electrical current, not all of the power calculated by the product of voltage and current, UI , is consumed. The product of U and I is called the apparent power. It is expressed as S . The unit of apparent power is the volt-ampere (VA). The apparent power is used to express the electrical capacity of a device that runs on AC electricity.

The true power that a device consumes is called active power (or effective power). It is expressed as P . This power corresponds to the AC power discussed in the previous section.

$$S = UI \text{ [VA]}$$

$$P = UI\cos\phi \text{ [W]}$$

$\cos\phi$ is called the power factor and is expressed as λ . It indicates the portion of the apparent power that becomes true power.

Reactive Power

If current I lags voltage U by ϕ , current I can be broken down into a component in the same direction as voltage U , $I\cos\phi$, and a perpendicular component, $I\sin\phi$. Active power P , which is equal to $UI\cos\phi$, is the product of voltage U and the current component $I\cos\phi$. The product of voltage U and the current component $I\sin\phi$ is called the reactive power. It is expressed as Q . The unit of reactive power is the var.

$$Q = UI\sin\phi \text{ [var]}$$

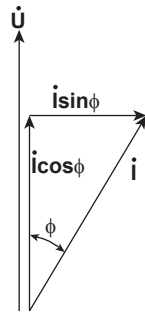

The relationship between S , the apparent power, P , the active power, and Q , the reactive power is as follows:

$$S^2 = P^2 + Q^2$$

Harmonics

Harmonics refer to all sine waves whose frequency is an integer multiple of the fundamental wave (normally a 50 Hz or 60 Hz sinusoidal power line signal) except for the fundamental wave itself. The input currents that flow through the power rectification circuits, phase control circuits, and other circuits used in various kinds of electrical equipment generate harmonic currents and voltages in power lines. When the fundamental wave and harmonic waves are combined, waveforms become distorted, and interference sometimes occurs in equipment connected to the power line.

Terminology

The terminology related to harmonics is described below.

- **Fundamental wave (fundamental component)**
The sine wave with the longest period among the different sine waves contained in a periodic complex wave. Or the sine wave that has the fundamental frequency within the components of the complex wave.
- **Fundamental frequency**
The frequency corresponding to the longest period in a periodic complex wave. The frequency of the fundamental wave.
- **Distorted wave**
A wave that differs from the fundamental wave.
- **Higher harmonic**
A sine wave with a frequency that is an integer multiple (twice or more) of the fundamental frequency.
- **Harmonic component**
A waveform component with a frequency that is an integer multiple (twice or more) of the fundamental frequency.
- **Harmonic distortion factor**
The ratio of the rms value of the specified nth order harmonic contained in the distorted wave to the rms value of the fundamental wave (or all signals).
- **Harmonic order**
The integer ratio of the harmonic frequency with respect to the fundamental frequency.
- **Total harmonic distortion**
The ratio of the rms value of all harmonics to the rms value of the fundamental wave (or all signals).

Some of the effects of harmonics on electrical devices and equipment are explained in the list below.

- **Synchronization capacitors and series reactors**
Harmonic current reduces circuit impedance. This causes excessive current flow, which can result in vibration, humming, overheat, or burnout.
- **Cables**
Harmonic current flow through the neutral line of a three-phase four-wire system will cause the neutral line to overheat.
- **Voltage transformers**
Harmonics cause magnetostrictive noise in the iron core and increase iron and copper loss.
- **Circuit breakers and fuses**
Excessive harmonic current can cause erroneous operation and blow fuses.
- **Communication cables**
The electromagnetic induction caused by harmonics creates noise voltage.
- **Control devices**
Harmonic distortion of control signals can lead to erroneous operation.
- **Audio visual devices**
Harmonics can cause degradation of performance and service life, noise-related video flickering, and damaged parts.

AC RLC Circuits

Resistance

The current i when an AC voltage whose instantaneous value $u = U_m \sin \omega t$ is applied to load resistance R [Ω] is expressed by the equation below. I_m denotes the maximum current.

$$i = \frac{U_m}{R} \sin \omega t = I_m \sin \omega t$$

Expressed using rms values, the equation is $I = U/R$.

There is no phase difference between the current flowing through a resistive circuit and the voltage.

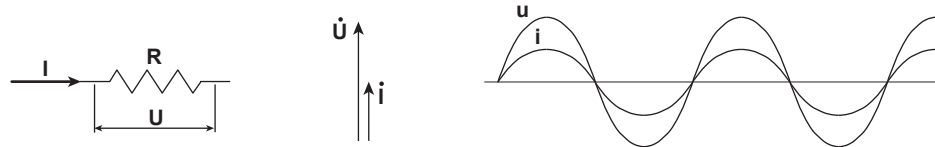

Inductance

The current i when an AC voltage whose instantaneous value $u = U_m \sin \omega t$ is applied to a coil load of inductance L [H] is expressed by the equation below.

$$i = \frac{U_m}{X_L} \sin \left(\omega t - \frac{\pi}{2} \right) = I_m \sin \left(\omega t - \frac{\pi}{2} \right)$$

Expressed using rms values, the equation is $I = U/X_L$. X_L is called inductive reactance and is defined as $X_L = \omega L$. The unit of inductive reactance is Ω .

Inductance works to counter current changes (increase or decrease), and causes the current to lag the voltage.

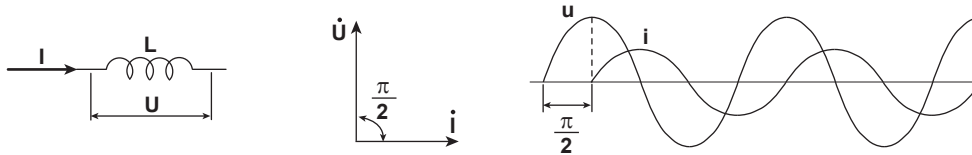

Capacitance

The current i when an AC voltage whose instantaneous value $u = U_m \sin \omega t$ is applied to capacitance C [F] is expressed by the equation below.

$$i = \frac{U_m}{X_C} \sin \left(\omega t + \frac{\pi}{2} \right) = I_m \sin \left(\omega t + \frac{\pi}{2} \right)$$

Expressed using rms values, the equation is $I = U/X_C$. X_C is called capacitive reactance and is defined as $X_C = 1/\omega C$. The unit of capacitive reactance is Ω .

When the polarity of the voltage changes, the largest charging current with the same polarity as the voltage flows through the capacitor. When the voltage decreases, discharge current with the opposite polarity of the voltage flows. Thus, the current phase leads the voltage.

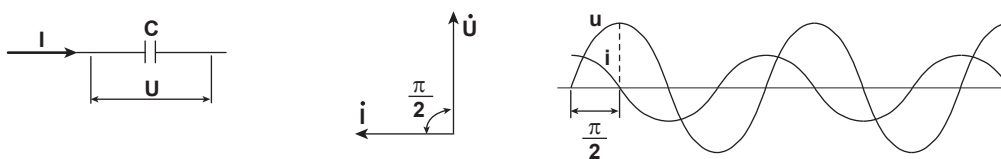

Series RLC Circuits

The equations below express the voltage relationships when resistance R_S [Ω], inductance L [H], and capacitance C [F] are connected in series.

$$\begin{aligned}
 U &= \sqrt{(U_{R_S})^2 + (U_L - U_C)^2} = \sqrt{(IR_S)^2 + (IX_L - IX_C)^2} \\
 &= I\sqrt{(R_S)^2 + (X_L - X_C)^2} = I\sqrt{R_S^2 + X_S^2} \\
 I &= \frac{U}{\sqrt{R_S^2 + X_S^2}}, \quad \phi = \tan^{-1} \frac{X_S}{R_S}
 \end{aligned}$$

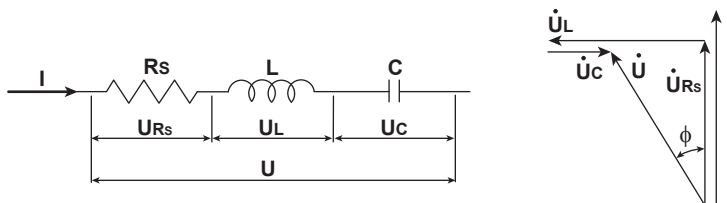

The relationship between resistance R_S , reactance X_S , and impedance Z is expressed by the equations below.

$$\begin{aligned}
 X_S &= X_L - X_C \\
 Z &= \sqrt{R_S^2 + X_S^2}
 \end{aligned}$$

Parallel RLC Circuits

The equations below express the current relationships when resistance R_P [Ω], inductance L [H], and capacitance C [F] are connected in parallel.

$$\begin{aligned}
 I &= \sqrt{(I_{R_P})^2 + (I_L - I_C)^2} = \sqrt{\left(\frac{U}{R_P}\right)^2 + \left(\frac{U}{X_L} - \frac{U}{X_C}\right)^2} \\
 &= U\sqrt{\left(\frac{1}{R_P}\right)^2 + \left(\frac{1}{X_L} - \frac{1}{X_C}\right)^2} = U\sqrt{\left(\frac{1}{R_P}\right)^2 + \left(\frac{1}{X_P}\right)^2} \\
 U &= \frac{I R_P X_P}{\sqrt{R_P^2 + X_P^2}}, \quad \phi = \tan^{-1} \frac{R_P}{X_P}
 \end{aligned}$$

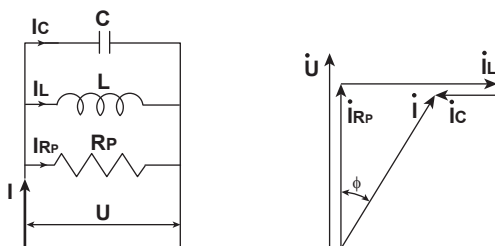

The relationship between resistance R_P , reactance X_P , and impedance Z is expressed by the equations below.

$$\begin{aligned}
 X_P &= \frac{X_L X_C}{X_C - X_L} \\
 Z &= \frac{R_P X_P}{\sqrt{R_P^2 + X_P^2}}
 \end{aligned}$$

Index

Numerics

	Page
3 phase resolver	16-21
3 Phase Resolver	16-21
16-CH module sampling timing	2-24

A

	Page
AC:.....	2-6
ACCEL.....	2-6
acceleration	2-30
accumulation	5-7
AC power	App-79
acquisition conditions	3-16
acquisition method.....	3-16
acquisition mode.....	3-7
acquisition time.....	3-15
actions	15-1
additional option license key input.....	23-6
A Delay B trigger.....	4-10
all channel setup.....	2-63
real time math function.....	16-2
all sub channel settings	
16-CH Temperature/Voltage Input Module.....	2-22
CAN bus signal monitoring.....	2-46
LIN bus signal monitoring.....	2-52
SENT signal monitoring	2-59
alternating current vector display.....	App-77
analysis mode	
harmonic analysis	17-12
power analysis	17-4
analysis settings	17-9
AND trigger.....	4-13
angle cursor.....	10-6
angle of rotation.....	16-5
angular velocity.....	App-76
apparent power.....	App-80
application	1-2
APPLICATION	1-2
arc tangent.....	16-14
Area2 Mode	11-8
area determination method.....	App-1
ASCII	19-4, App-13
assignments to display groups	2-10
A to B(N) trigger.....	4-9
auto calibration	23-1
automated measurement of waveform parameters.....	11-1
auto naming.....	19-2
auto scrolling	7-5
auto setup.....	1-1
average setting	
FFT.....	12-8
math	13-6
averaging mode.....	3-7
AX+B	2-16

B

	Page
balance	2-26
bandwidth limit.....	2-8
basic arithmetic.....	13-1
basic arithmetic with coefficients	16-4
beep sound.....	23-8
bias	2-30
binary.....	19-4, 23-6

binary computation	13-2
bit data display order	23-6
bit mapping	2-41
bit rate (CAN).....	2-48
bit rate (LIN).....	2-53
box average mode.....	3-7
bridge voltage	2-26
brightness.....	5-2
burnout	2-20
Butterworth	App-45

C

	Page
calculation frequency	App-34
calculation period	
harmonic analysis	17-12
power analysis	17-8
calibration	23-1
power integration.....	23-1
CAN bus signal monitoring	2-43
CAN FD	2-43
CAN FD frame format.....	2-44
CAN frame format.....	2-43
CAN frame reading.....	2-46
capacitance	App-82
captured waveform display number.....	9-6
capture mode.....	3-14
channel setup	2-1
chattering.....	2-39
checksum (LIN)	2-54
clear trace.....	23-2
click sound.....	23-7
Clock Tick	2-56
clock trigger	4-19
coefficient multiplied by addition or subtraction of sources	16-16
coherence function	App-9
color	5-6
color theme.....	5-4
combine display	
FFT window.....	12-7
X-Y window	6-5
comment.....	19-3
communication interface types.....	23-2
computation format (frequency module).....	App-20
constants	13-5
continuous statistical processing	11-10
conversion ratio, current-to-voltage	2-7
copy	2-65
cosine	16-14
cosine phase signal	16-18
CRC type	2-56
cross spectrum	App-9
cursor measurement.....	10-1
FFT waveforms	12-6
X-Y waveform.....	6-2
cycle averaging.....	13-7
cycle frequency.....	4-17
cyclic statistical processing.....	11-10

Index

D	Page
data format	19-3
data frame reading (CAN)	2-46
data loading	19-10
Data Nibble Number	2-56
data saving (SAVE key)	19-9
data type (CAN)	2-47
data type (LIN)	2-53
data type (SENT)	2-61, 2-62
DC	2-6
DC offset cancellation	2-14, 2-65
deceleration prediction	2-37
default setup	1-1
definition file (CAN/CAN FD)	2-49
definitions file (LIN)	2-54
delay between channels	11-4
delta math	17-2
delta wiring	App-78
demodulation	16-19
demodulation of the pulse width modulated signal	16-19
deskewing	2-15
detailed display settings	5-3
analysis result font size	5-3
channel information	5-4
channel information width	5-4
color theme	5-4
extra window	5-3
horizontal scale display format	5-3
indicator display	5-4
manual event	5-4
number of analysis result display lines	5-3
scale display	5-3
scale font size	5-3
trace label	5-4
differentiation (/G03 option)	16-4
digital filter (/G02, /G05 option)	App-3
digital filter (/G03, /G05 option)	2-65
display format	5-2, 7-4
display group	5-6
display labels	2-3
display mode (history)	9-2
display pattern	5-1
distal	11-6
distance	2-35
distorted wave	App-81
dot display	3-3
dual capture	3-13
duty cycle	2-33
E	Page
edge count	16-18
Edge On A trigger	4-11
edge search	8-1
edge trigger	4-19
Edit Favorites (application menu)	1-2
effective power	16-12, App-80
effective power integration	16-12
efficiency settings	17-10
electrical angle	16-15, App-58
electromagnetic pickup	2-38
Enhanced	4-9
enhanced parameter measurement	11-8
envelope mode	3-7
error channel	2-57
error count	2-57, 2-58
Error Count	2-58
Error Trigger	2-58
error type	2-57
Ethernet Communication	20-1
event search	8-4
excitation signal	16-18, App-58
excitation signal (3 phase resolver)	16-21
exponential window setting	12-3
expressions (/G02 option)	13-4
external clock	3-2
external sample output	23-7
extra window	5-3
F	Page
Fast Channel CRC	2-57
Fast Channel Multiplexing	2-56
FFT	12-1
FFT function	App-7
FFT points	12-1
file copying	19-12
file division	3-10
file list	19-11
file name	19-3
file operation	19-11
filter setup	13-5
filter type (digital filter)	2-66
FIR	App-32
force window	App-11
form factor	App-77
frame format (CAN)	2-43
frame format (LIN)	2-51
frame reading (CAN)	2-46
frame reading (LIN)	2-52
frequency	16-17
frequency measurement	2-32
FTP server	20-3
functions	13-4
fundamental component	App-81
fundamental frequency	App-81
fundamental wave	App-81
FV setting	2-32
G	Page
gain	2-31
gain adjustment	2-14
gauge factor	2-26
Gauss	App-43
GND	2-6
GO/NO-GO	14-1
GO/NO-GO determination	
waveform parameters	14-4
waveform zone	14-2
grid	5-2
group delay characteristic	App-33
group selection	5-2
H	Page
harmonic analysis	17-11
harmonic component	App-81
harmonic distortion factor	App-81
harmonic order	App-81
harmonics	App-81
harmonic window	17-13
hexadecimal	23-6
higher harmonic	App-81
high-speed sampling (dual capture)	3-14
hilbert function	App-4
history	9-1
history map	9-3

history waveform search.....	9-3	marker cursor (T-Y waveform).....	10-4
horizontal and vertical cursor (T-Y waveform).....	10-7	marker cursor (X-Y waveform).....	6-4
horizontal and vertical cursor (X-Y waveform).....	6-5	math.....	13-1
horizontal cursor (T-Y waveform).....	10-1	math delay.....	App-36
horizontal cursor (X-Y waveform).....	6-3	MATLAB.....	19-4
horizontal scale.....	12-7	Mean.....	App-55
hysteresis.....	2-39	measurement function.....	17-1, 17-2
I		measurement items.....	11-1
Page		measurement location indicator.....	11-7
IEEE1588.....	21-2	measurement resolution.....	2-5
master mode.....	21-2	memory test.....	23-8
IIR.....	App-32, App-45	menu area display, switching.....	5-4
IIR filter (digital filter).....	2-66	mesial.....	11-6
IMAGE SAVE key.....	18-3	message format (CAN).....	2-46
Indicator(measure).....	11-7	message (SENT).....	2-56
inductance.....	App-82	moving average.....	App-55
input coupling.....	2-6	moving average sample rate (digital filter).....	2-67
input coupling (16-CH Temperature/Voltage Input Module).....	2-23	multi-unit synchronization.....	22-1
instantaneous value.....	App-76	N	
integration.....	App-5, App-57	Page	
integration (/G03 option).....	16-5	network drive.....	20-6
internal clock.....	3-2	network printer.....	18-2, 20-6
internal SSD test.....	23-8	Nibble Value.....	2-57
interpolation method (T-Y waveform).....	5-5	numeric monitor.....	5-4
interpolation method (X-Y waveform).....	6-6	numeric monitor mode.....	17-16
inverted display.....	2-15	O	
J		Page	
Page		OFF.....	2-6
judgment conditions.....	14-3, 14-4	offset.....	2-12
K		one-cycle mode.....	11-7
Page		one-shot output.....	2-50
key lock.....	23-7, 23-9	On Start.....	3-8
knocking filter.....	16-16	operation mode.....	1-2, 3-1
L		operators.....	13-1
Page		operators (/G02 option).....	13-4
language.....	23-5	operators (/G03 option).....	16-3
LCD settings.....	23-5	OR trigger.....	4-12
level indicator.....	5-4	over limit.....	2-35
LIN bus signal monitoring.....	2-51	overview.....	23-9
linear scaling.....	2-16	P	
linear spectrum.....	App-7	Page	
line voltage.....	App-78	P1-P2.....	2-16
LIN frame format.....	2-51	password.....	23-7
LIN frame reading.....	2-52	Pause Pulse.....	2-56
listen only (CAN).....	2-48	peak computation.....	12-9, 13-7
logarithm.....	16-13	peak cursor.....	12-7
logic display method.....	23-6	pen marker.....	6-2
logic measurement.....	2-41	period.....	2-33
logic pattern search.....	8-4	period (/G03 option).....	16-17
logic signal and analog waveform conversion.....	16-10	period trigger.....	4-14
low-speed sampling auto scroll.....	7-5	phase (3 phase resolver).....	16-21
low-speed sampling display ratio.....	5-7	phase angle.....	App-77
low-speed sampling (dual capture).....	3-13	phase difference.....	App-77
low-speed sampling measurement.....	11-8	phase function.....	App-4
M		phase shifting.....	13-2
Page		port number.....	App-25
MAG knob.....	7-2	power.....	16-12, App-76
mail.....	20-5	power analysis.....	17-1
main unit.....	22-1	power factor.....	App-80
main window's display ratio.....	7-4	power integration.....	16-12
manual event.....	5-4	power integration calibration.....	23-1
Manual Reset.....	2-58	power-on action.....	23-6
manual reset (error count).....	2-58	power spectrum.....	App-8
manual trigger.....	4-1	power supply frequency.....	2-33
Manual Trigger.....	4-1	preferences.....	23-6
marker cursor (FFT waveform).....	12-6	pre-trigger.....	4-8
		printer.....	18-1, 18-2

Index

probe attenuation.....	2-7	Sharp.....	App-37
protection.....	19-12	shunt calibration.....	2-28, App-15
proximal.....	11-6	simple trigger.....	4-3
pull-up.....	2-40	sine.....	16-14
pulse average.....	2-37	sine phase signal.....	16-18, 16-21
pulse integration.....	2-33	sine signal phase.....	16-21
Pulse Number.....	2-57	Slow Channel CRC.....	2-57
pulse width.....	2-33	Slow CH type.....	2-56
pulse width computation.....	App-7	smoothing.....	2-36
pulse width trigger.....	4-15	smoothing filter's filter response (frequency module).....	App-21
PWM.....	16-19	snapshot.....	23-2
		SNTP.....	20-7
Q	Page	source channels.....	17-1
quartic polynomial.....	16-10	spectrum type.....	12-5
		speed.....	2-34
R	Page	square root.....	16-13
reactive power.....	App-80	SSD recording.....	3-9
read order.....	23-6	SSD recording setup.....	3-10
real time math (/G03, /G05 option).....	16-1, 16-24	start point.....	12-1
recording time.....	3-15	START/STOP.....	3-17
record length.....	3-5	startup mode.....	23-6
record selection.....	9-2	star wiring.....	App-78
reference cycle.....	4-17	statistical processing.....	11-9
reference junction compensation.....	2-20	statistical processing of history waveforms.....	11-12
remote control.....	23-2	stop prediction.....	2-37
reset (error count).....	2-58	storage device.....	19-1
reset (manually resetting the error count).....	2-58	storage device format.....	23-5
resistance.....	App-82	store, recall.....	23-1
resolver.....	16-18, App-58	strain.....	2-25
resynchronization jump width.....	2-48	strain balance.....	2-26
rms measurement.....	2-18	strain, fundamental definition expression.....	App-14
rms spectrum.....	App-8	sub unit.....	22-1
rms value.....	16-11	Successive Calibration Pulses (Option2).....	2-57
roll mode display.....	3-4	sync channel.....	4-18
rotating speed.....	16-8	synchronous operation.....	22-1
rotations, number of.....	2-33	system configuration.....	23-4
		T	Page
S	Page	tap.....	2-67
sample interval.....	3-15	TC.....	2-6
channel setup.....	2-15	TCP and UDP port numbers.....	App-25
sample point (CAN).....	2-48	TCP/IP.....	20-2
sample rate.....	3-4	TCP/IP 10G.....	20-2
channel setup.....	2-15	temperature measurement.....	2-19
samples, number of (CAN).....	2-48	temperature measurement (16-CH Temperature/Voltage Input Module).....	2-21
sampling timing.....	3-2	temperature unit.....	2-20
save destination.....		terminal setup.....	23-7
file list.....	19-2	terminator (CAN).....	2-49
multi-unit synchronization mode.....	19-2	thermocouple type.....	2-19
Save on Stop.....	15-3	threshold level.....	2-58
SCALE knob.....	2-3, 16-2	threshold (SENT).....	2-58
scale value.....	5-3	time base.....	3-11
scaling mode.....	13-3	time reference point.....	4-6
screen capture printing.....	18-1	time scale.....	3-2
screen capture saving.....	18-3	time search.....	8-5
screen types.....	5-1	time setting.....	23-4
SD memory card test.....	23-8	time stamp format.....	App-75
search.....	8-1	time synchronization.....	21-1
history waveform.....	9-3	GPS.....	21-1
self-test.....	23-8	IEEE1588.....	21-1
sensitivity.....	2-31	IRIG.....	21-1
sensor setup.....	2-26	time synchronization state.....	21-1
SENT message reading.....	2-56	time unit.....	2-35
SENT signal monitoring.....	2-55	torque.....	16-20
settings, initialization.....	1-1	total harmonic distortion.....	App-81
setup data loading.....	19-10	touch panel.....	23-8
setup data saving.....	19-7	trace label.....	5-4
setup data store/recall.....	23-1		

tracking filter	16-18, 16-21, App-59
trademarks.....	i
transfer function.....	App-9
trigger delay.....	4-7
trigger display.....	2-58
trigger hold-off.....	4-7
trigger hysteresis.....	4-5
trigger level.....	4-4
trigger mode.....	3-8
trigger position.....	4-5
trigger slope.....	4-5
trigger source.....	4-3
trigger type.....	4-1
T-Y waveform display window.....	5-1

U

Page

unit setup.....	4-8
update.....	23-5
upper and lower limits.....	2-13
USB function.....	23-3
USB keyboard language.....	23-5
USB printer.....	18-1
user-defined math function (/G02 option).....	13-3

V

Page

variables.....	13-4
vertical cursor (T-Y waveform).....	10-2
vertical cursor (X-Y waveform).....	6-3
vertical position.....	2-10
vertical POSITION knob.....	2-10
vertical scale.....	2-10, 12-4
DIV.....	2-10
SPAN.....	2-10
vertical scale (SCALE knob).....	2-3
vertical zoom.....	2-11
voltage measurement.....	2-2
voltage range (SENT).....	2-58

W

Page

waveform acquisition.....	3-1, 3-17
waveform area.....	App-1
waveform arrangement.....	5-6
waveform data loading.....	19-10
waveform data saving.....	19-2
waveform display decimation (T-Y waveform).....	5-5
waveform display decimation (X-Y waveform).....	6-6
waveform display section.....	7-3
waveform input on/off.....	2-2
waveform input on/off (16-CH Temperature/Voltage Input Module).....	2-21
waveform parameter search.....	9-4
waveform search.....	8-1
waveform zoom.....	7-1
wave window trigger.....	4-16
Web server.....	20-4
window function.....	12-2
window layout	
FFT window.....	12-7
harmonic window.....	17-13
X-Y window.....	6-5
zoom window.....	7-4
wiring system.....	17-4
wiring unit.....	17-1

X

Page

X-Y window.....	6-1
-----------------	-----

Z

Page

zero crossing.....	2-38
zone search.....	9-4
zoom factor.....	7-2
zoom link.....	7-2
zoom method (vertical axis).....	2-10
zoom position.....	7-3
zoom POSITION knob.....	7-3
zoom source waveform.....	7-5
zoom window.....	7-2